



Kit, Welder Cable Carrier TRLR10W

Welder Cable Carrier Installation Instructions

The following instructions are intended to assist the user in the installation of the TRLR10W welder cable carriers to the trailer frame. Please read all assembly instructions before installing the kit.

REQUIRED TOOLS

- 3/8" ratchet w/ 9/16" socket extension
- 9/16" open end wrench

PARTS

Verify that all parts are accounted for. See Figure 1 and Table 1.

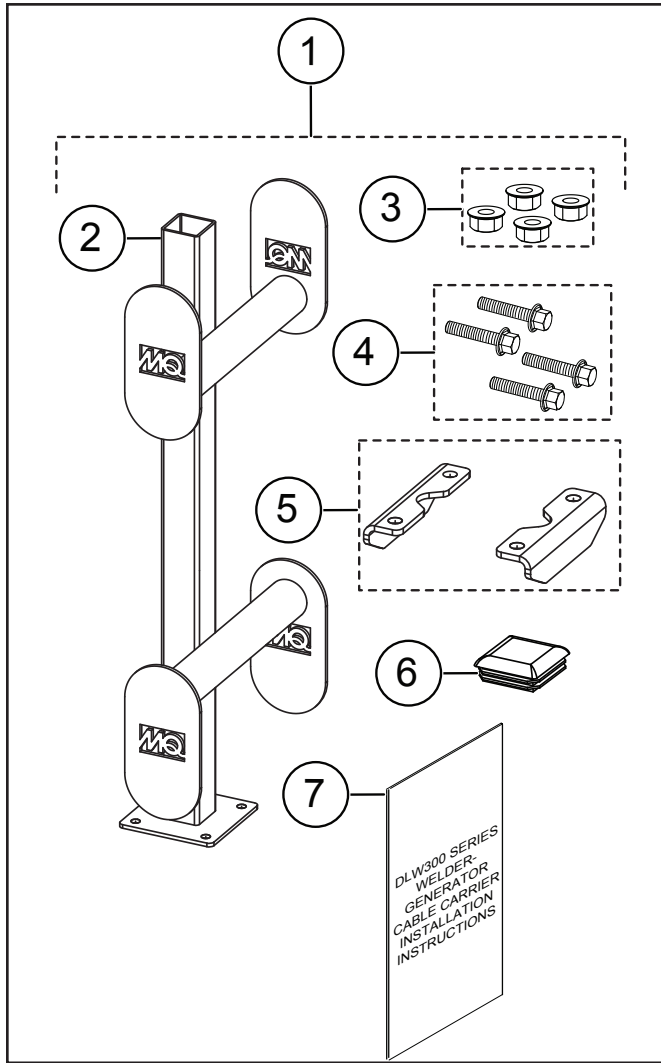

Figure 1. Welder Cable Carrier Installation Kit

Table 1. Welder Cable Carrier Installation Kit

Item No.	Part No.	Description	QTY.	Remarks
1	59067	Kit, Welder Cable Carrier TRLR10W	1	Includes items 2-7
2	59062	Welder Cable Carrier	1	
3	21781	Nut, Flanged 3/8-16 Serrated PLTD	4	
4	9167	Screw, HHFS, 3/8-16 x 2.25"	4	
5	59070	Clamp, Cable Carrier, TRLR10W	2	
6	44052	Cap, Tube	1	
7	59065	Instructions, TRLR10WCC Kit Installation	1	

WORK SAFELY!

Only a **qualified service technician** with proper training should perform this installation. Follow all shop safety rules when performing this installation.

PREPARATION

1. Place the trailer in an area free of dirt and debris. Make sure it is on secure level ground with chock blocks underneath each wheel to prevent the trailer from rolling.

MOUNTING WELDER CABLE CARRIER

1. Locate the welder cable carrier (P/N 59062) in the kit.
2. Place the welder cable carrier mounting bracket onto the rectangular tube located at the tongue of the trailer frame as shown in Figure 2.
3. Make sure the welder cable carrier mounting bracket holes are not blocked by the rectangular tube.
4. Locate the four 3/8-16 x 2.25" HHFS screws (P/N 9167) from the kit and insert the four screws into the welder cable carrier mounting bracket holes.
5. Locate the two welder cable carrier clamps (P/N 59070) in the kit.
6. Align the two welder cable carrier clamps with the welder cable carrier mounting bracket holes and loose screws from the bottom of the rectangular tube.

NOTICE

Align the two welder cable carrier clamps with the V-shaped tie down welded to the rectangular tube.

7. Locate the four 3/8-16 nuts (P/N 21781) in the kit.
8. Using a 9/16" socket and open ended wrench, secure the welder cable carrier to the rectangular tube (Figure 2) with the four 3/8-16 x 2.25" HHFS screws and 3/8-16 nuts.
9. Torque the screws and nuts to 26 ft-lbs (35.3 N•m).
10. Mount and secure the welder cable carrier cap as shown in Figure 2.
11. Check and make sure the welder cable carrier and clamps are tightly secured to the rectangular tube.

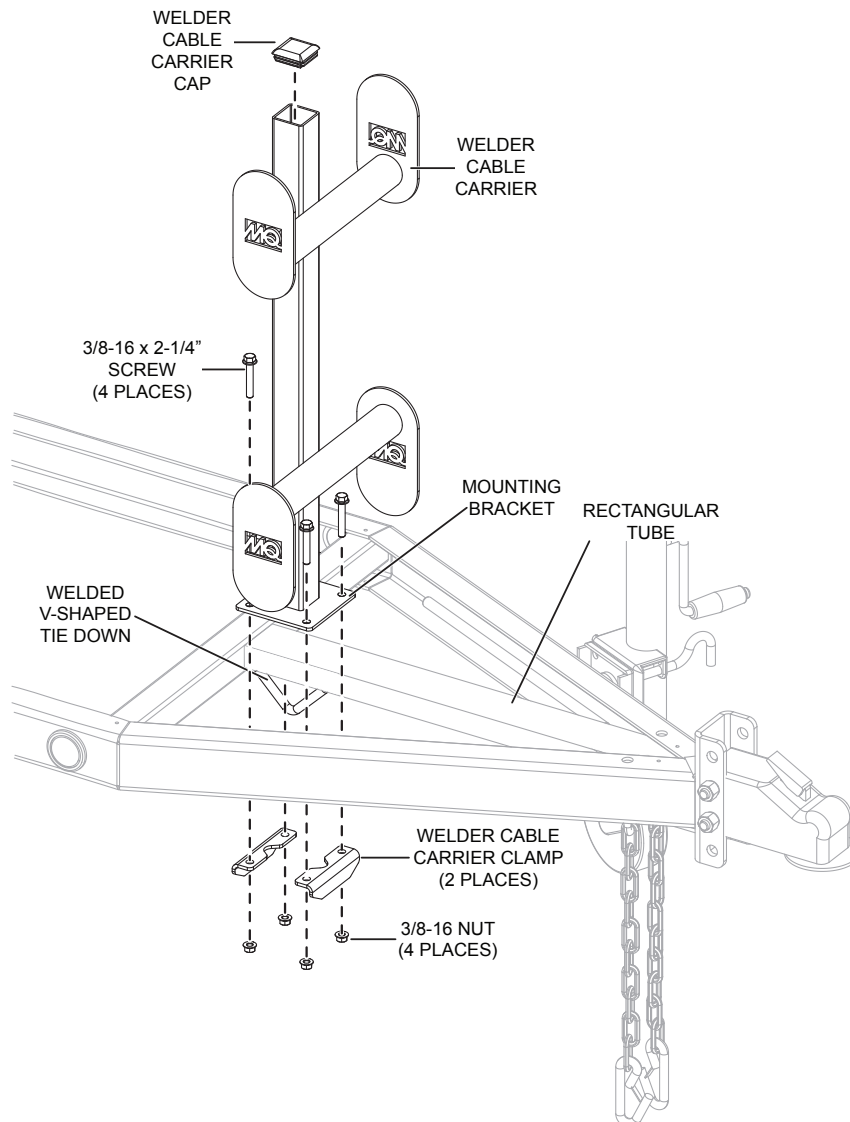

Figure 2. Welder Cable Carrier Installation



Kit, Welder Cable Carrier TRLR10W

Welder Cable Carrier Installation Instructions

HERE'S HOW TO GET HELP

PLEASE HAVE THE MODEL AND SERIAL
NUMBER ON-HAND WHEN CALLING

UNITED STATES

Multiquip Corporate Office

18910 Wilmington Ave. Tel. (800) 421-1244
Carson, CA 90746 Fax (310) 537-3927
Contact: mq@multiquip.com

Service Department

800-421-1244 Fax: 310-537-4259
310-537-3700

Technical Assistance

800-478-1244 Fax: 310-943-2238

MQ Parts Department

800-427-1244 Fax: 800-672-7877
310-537-3700 Fax: 310-637-3284

Warranty Department

800-421-1244 Fax: 310-943-2249
310-537-3700

CANADA

Multiquip

4110 Industriel Boul. Tel: (450) 625-2244
Laval, Quebec, Canada H7L 6V3 Tel: (877) 963-4411
Contact: infocanda@multiquip.com Fax: (450) 625-8664

UNITED KINGDOM

Multiquip (UK) Limited Head Office

Unit 2, Northpoint Industrial Estate, Tel: 0161 339 2223
Globe Lane, Fax: 0161 339 3226
Dukinfield, Cheshire SK16 4UJ
Contact: sales@multiquip.co.uk

© COPYRIGHT 2015, MULTIQUIP INC.

Multiquip Inc and the MQ logo are registered trademarks of Multiquip Inc. and may not be used, reproduced, or altered without written permission. All other trademarks are the property of their respective owners and used with permission.

The information and specifications included in this publication were in effect at the time of approval for printing. Illustrations, descriptions, references and technical data contained in this document are for guidance only and may not be considered as binding. Multiquip Inc. reserves the right to discontinue or change specifications, design or the information published in this publication at any time without notice and without incurring any obligations.

Your Local Dealer is:

