

# Wiring diagram (multifunction display)

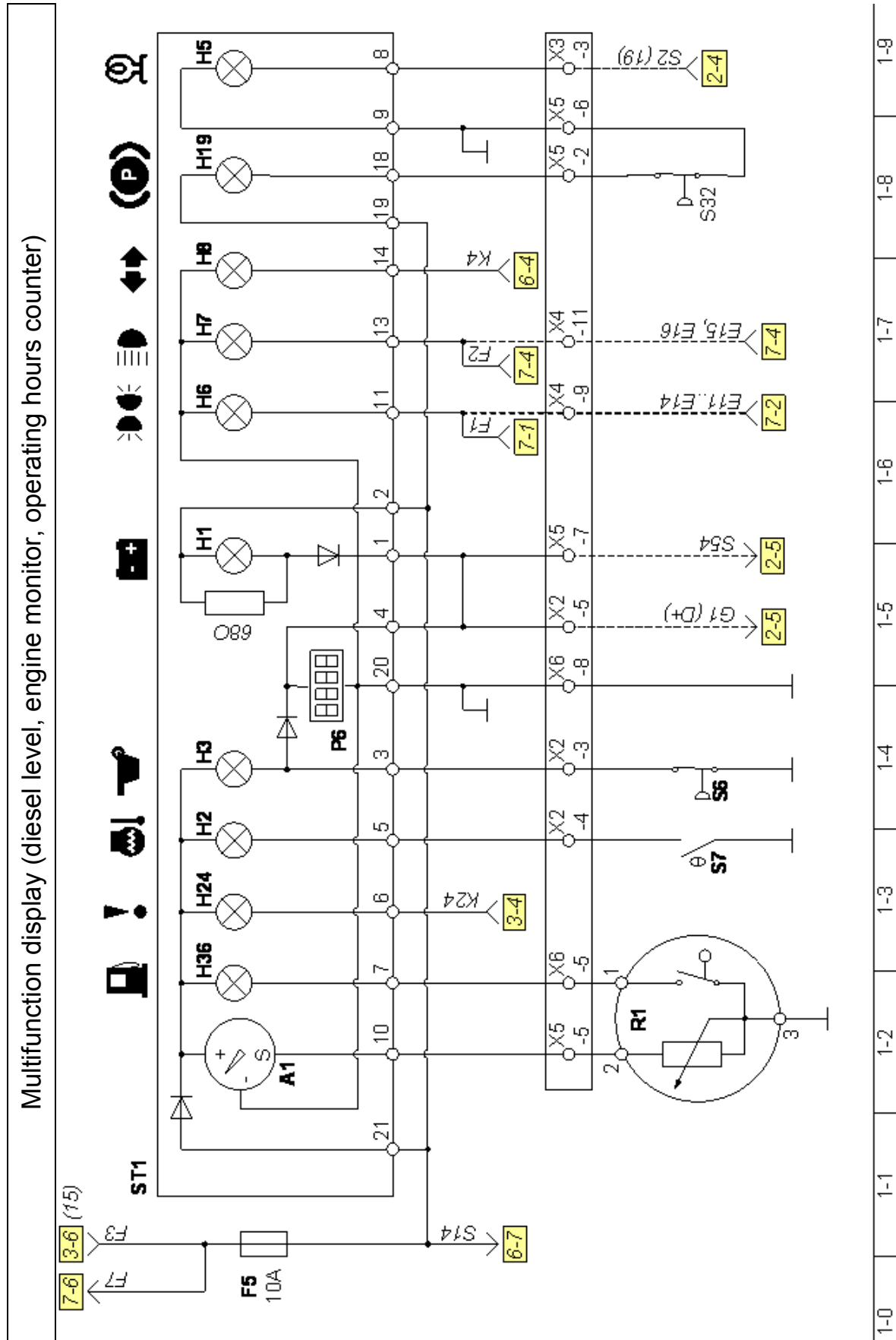

# Wiring diagram (engine start/stop)

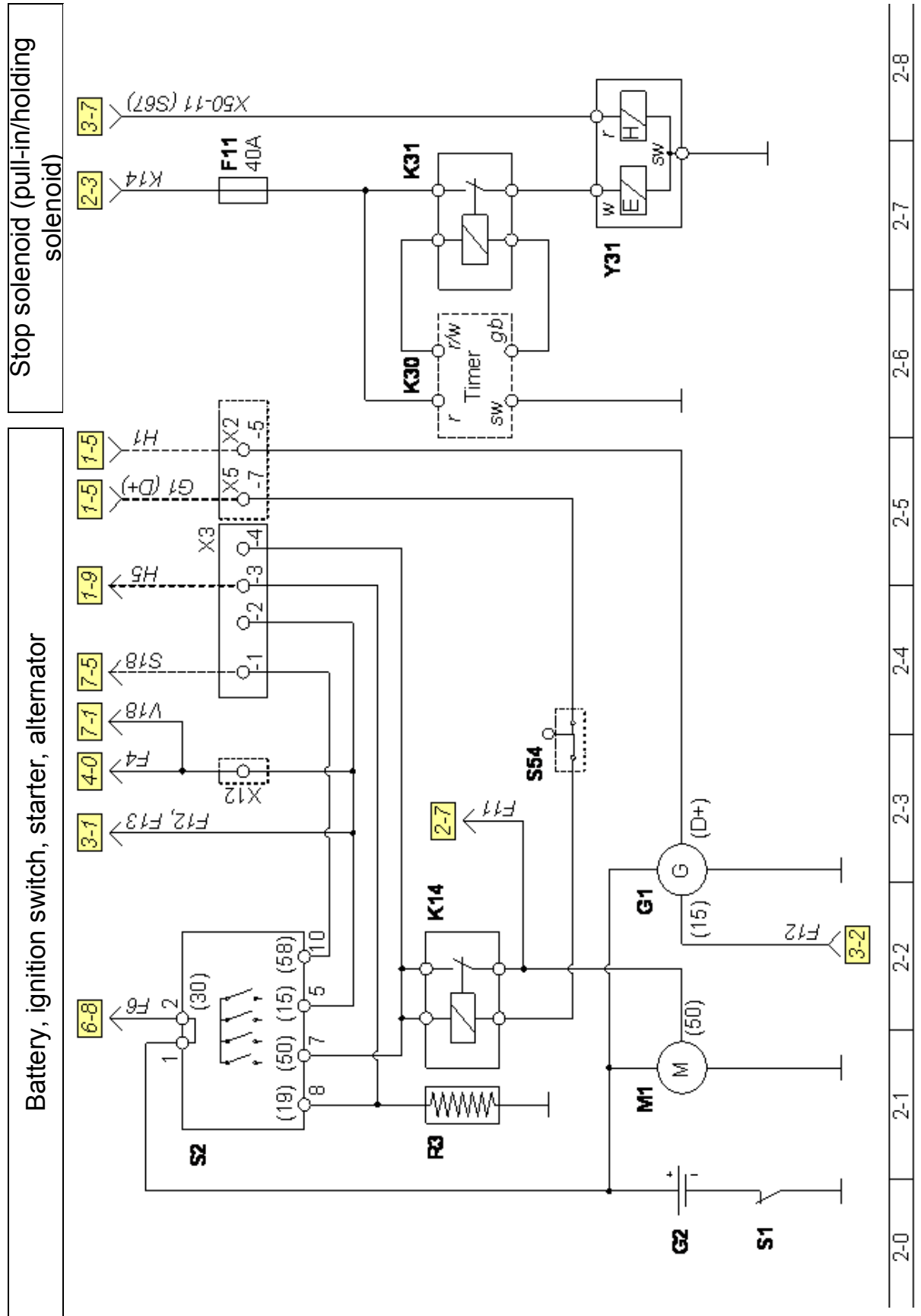

2-0	2-1	2-2	2-3	2-4	2-5	2-6	2-7	2-8
-----	-----	-----	-----	-----	-----	-----	-----	-----

# Wiring diagram (emergency stop / oil cooler, diesel pump)

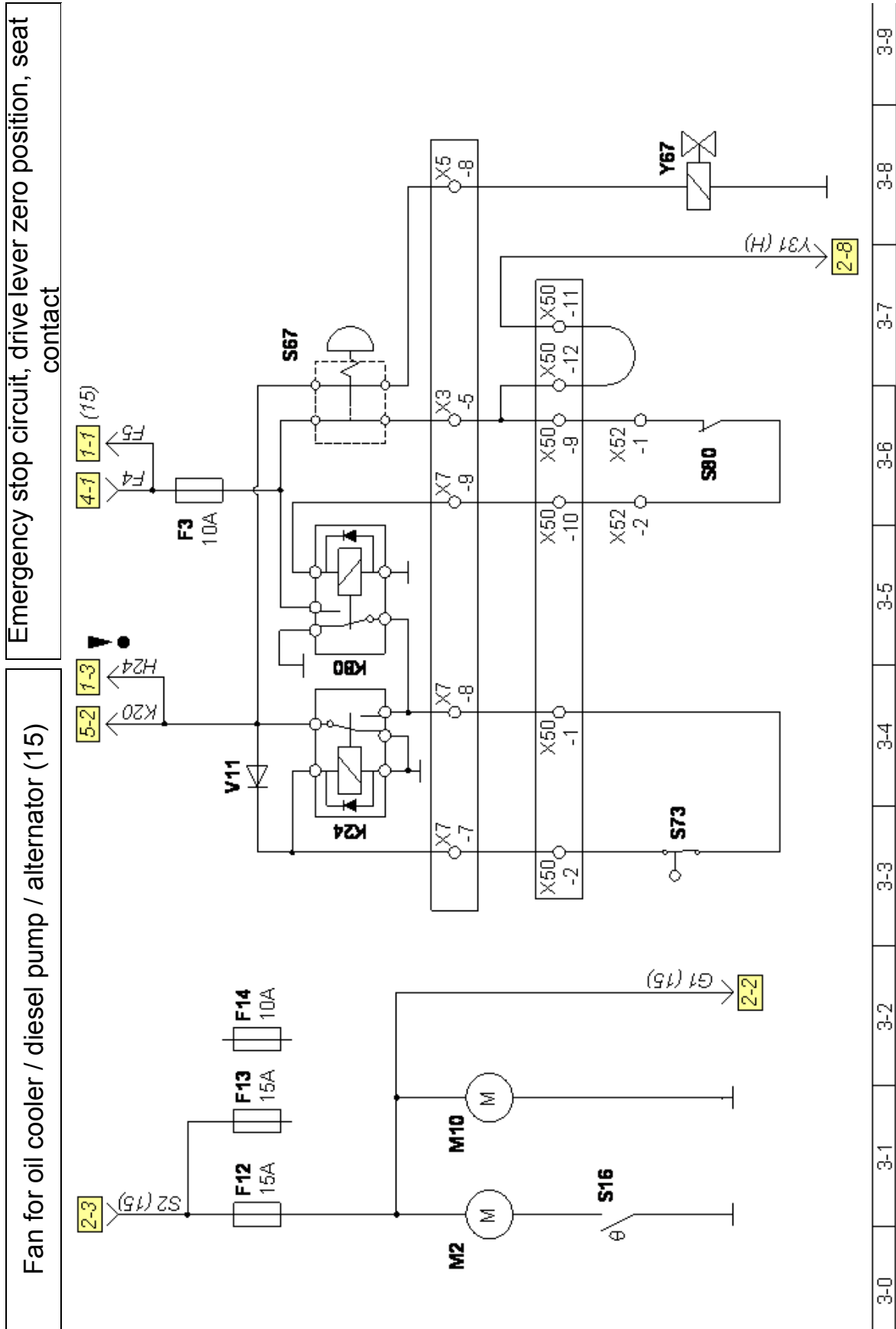

3-0	3-1	3-2	3-3	3-4	3-5	3-6	3-7	3-8	3-8
-----	-----	-----	-----	-----	-----	-----	-----	-----	-----

# Wiring diagram (sprinkler)

**Interval sprinkler (optional)**

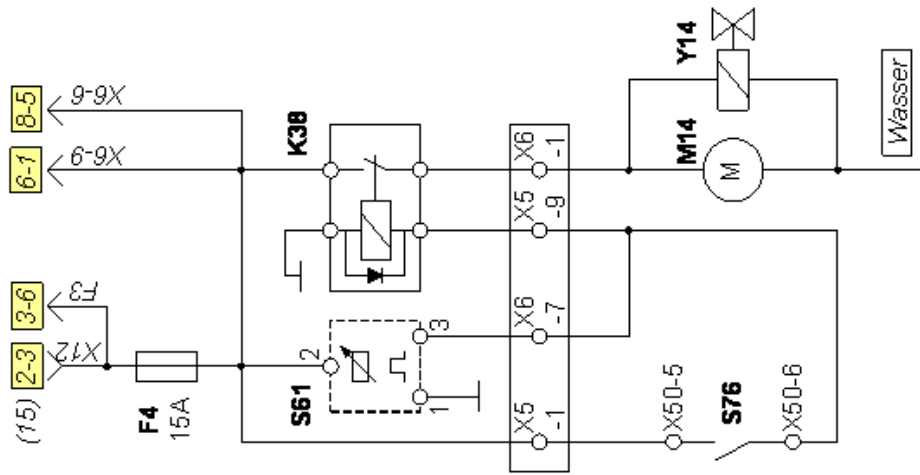

**Pressure sprinkler combined version (optional)**

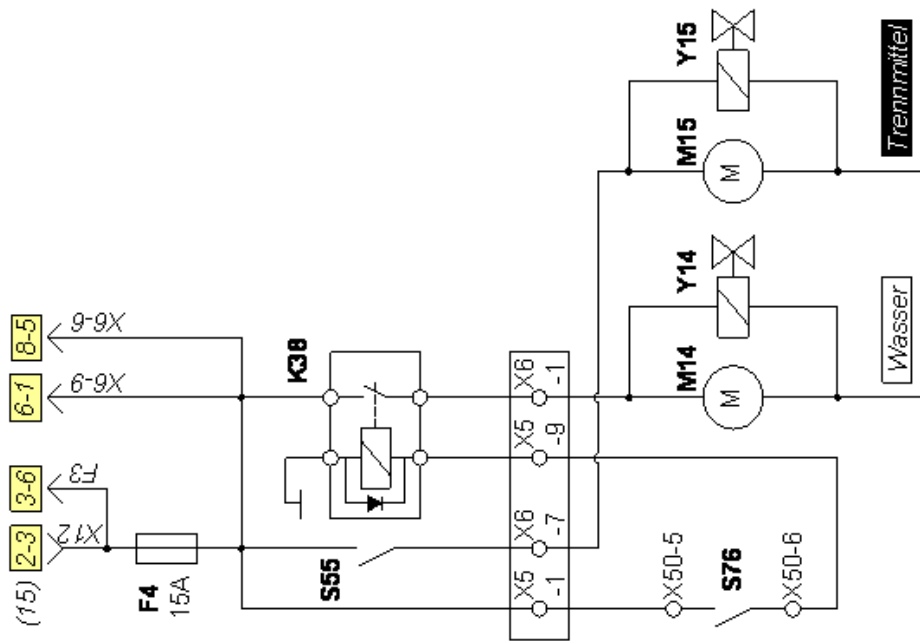

**Pressure sprinkler standard**

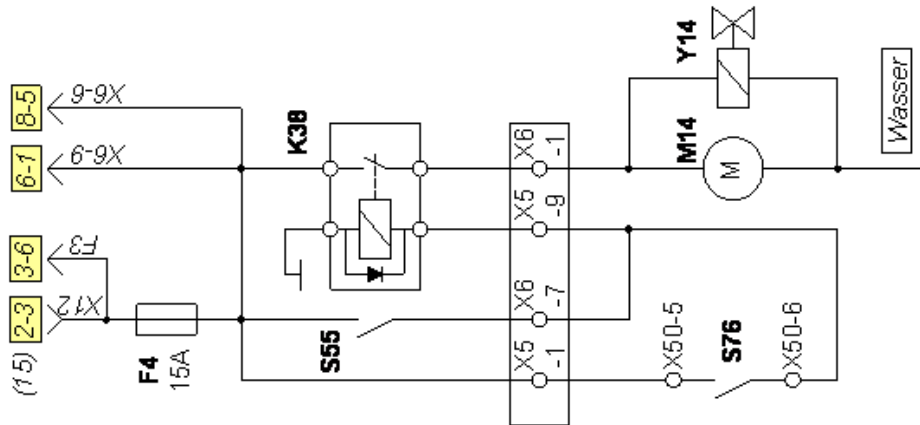

4-0	4-1	4-2	4-3	4-4	4-5	4-6	4-7	4-8	4-9
-----	-----	-----	-----	-----	-----	-----	-----	-----	-----

# Wiring diagram (vibration)

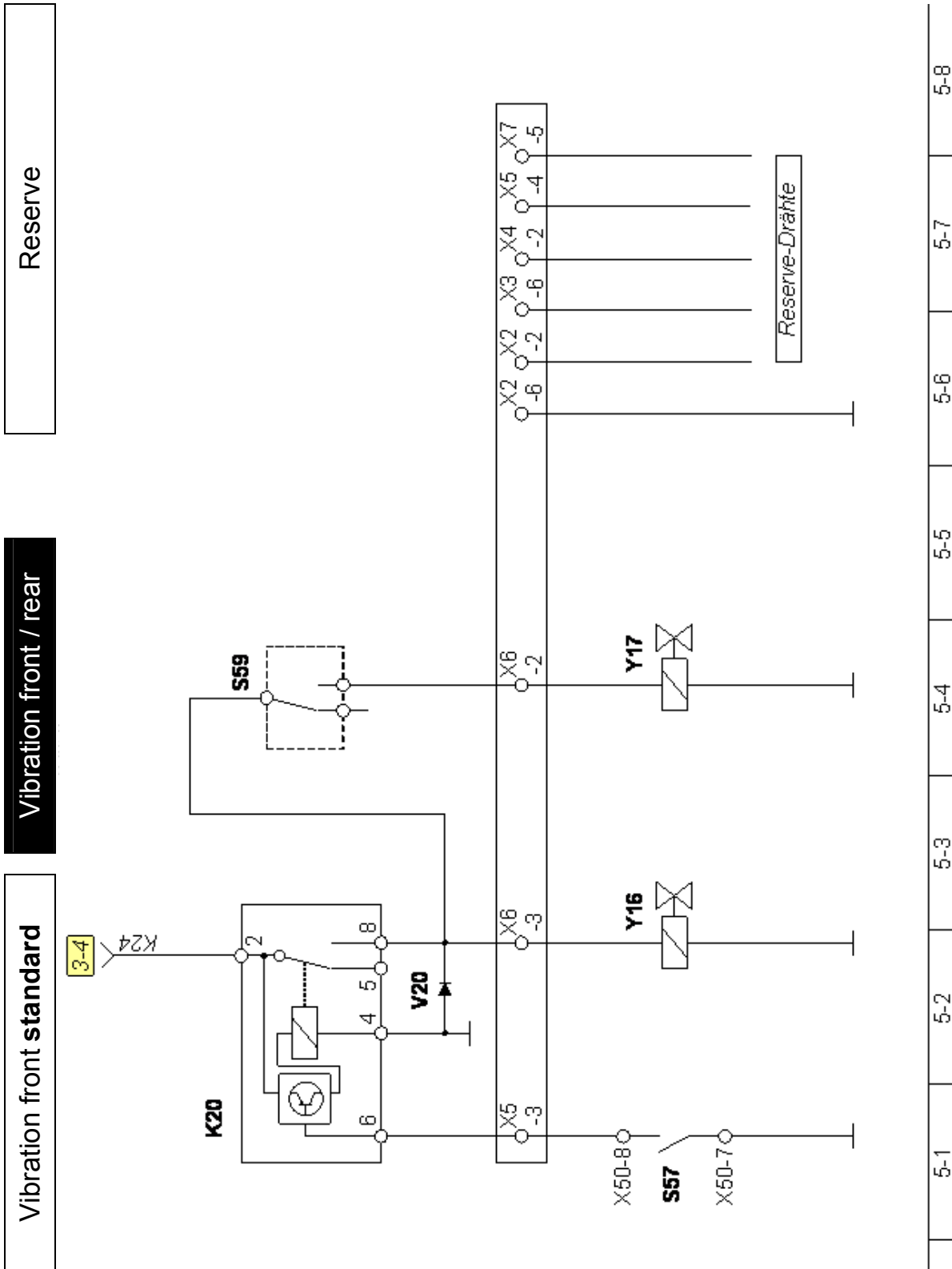

# Wiring diagram (horn, indicators)

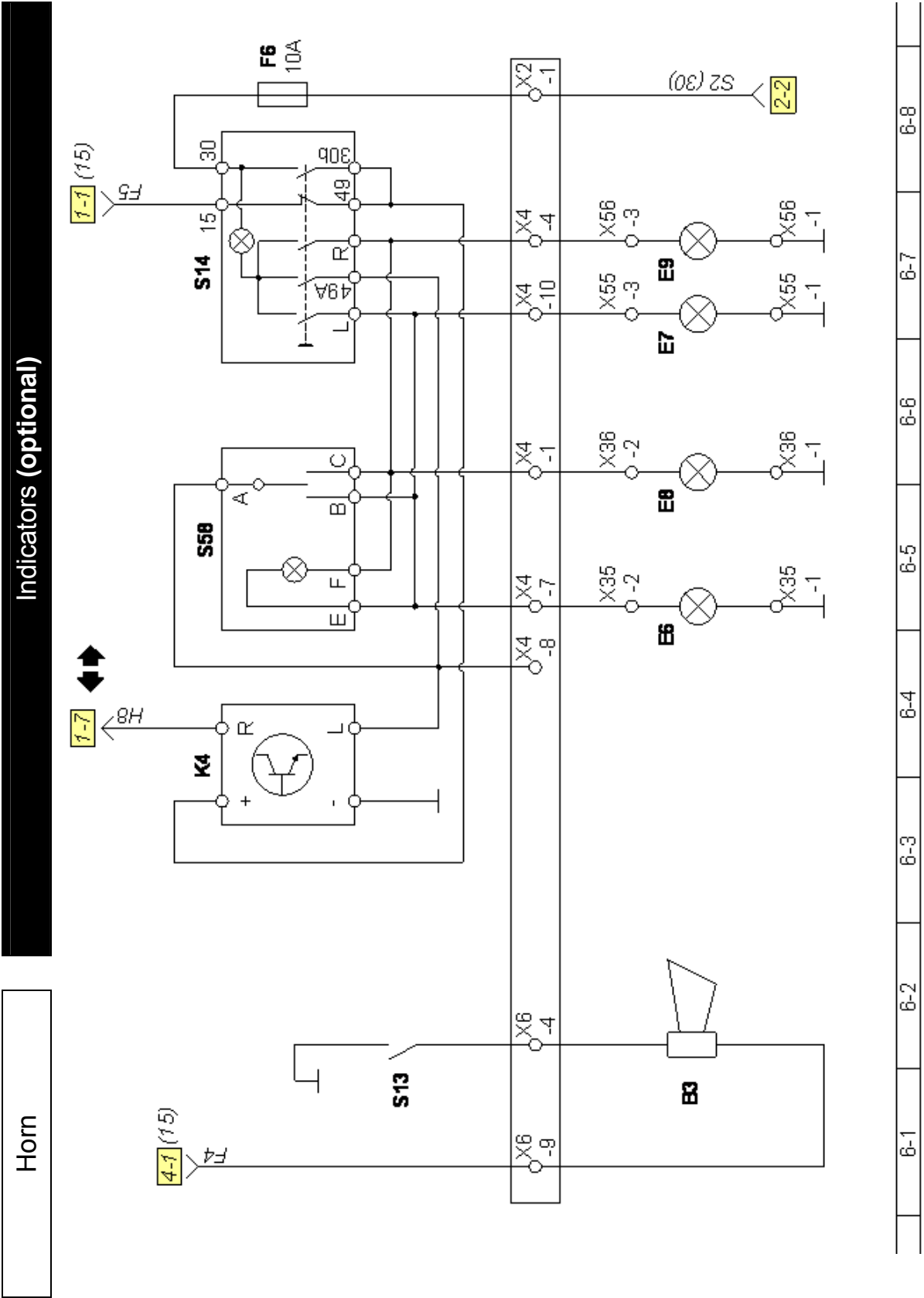

# Wiring diagram (lights)

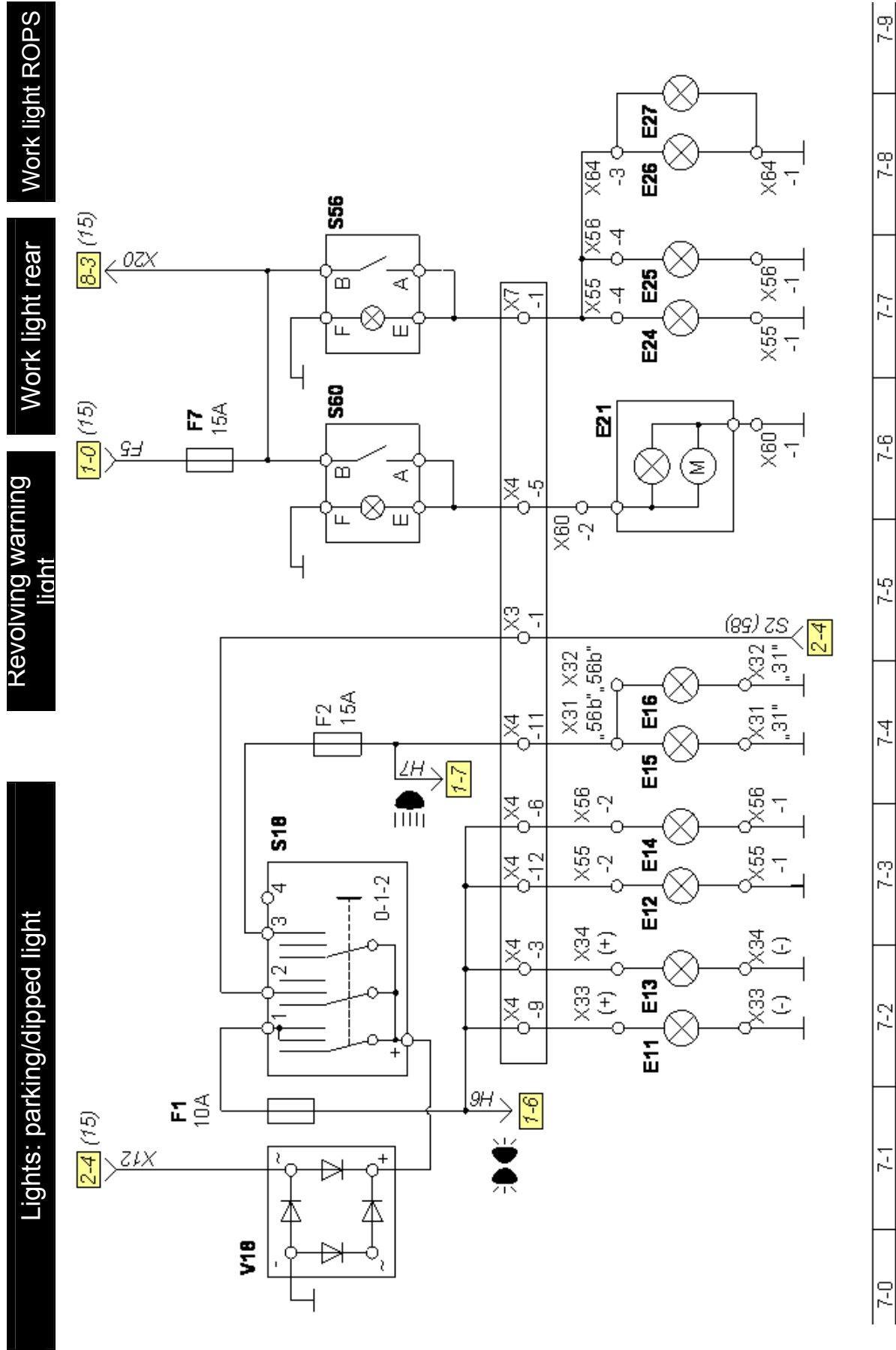

Lights: parking/dipped light

Revolving warning light

Work light rear

Work light ROPS

7-0	7-1	7-2	7-2	7-3	7-4	7-4	7-5	7-6	7-7	7-8	7-9
-----	-----	-----	-----	-----	-----	-----	-----	-----	-----	-----	-----

# Wiring diagram (options)

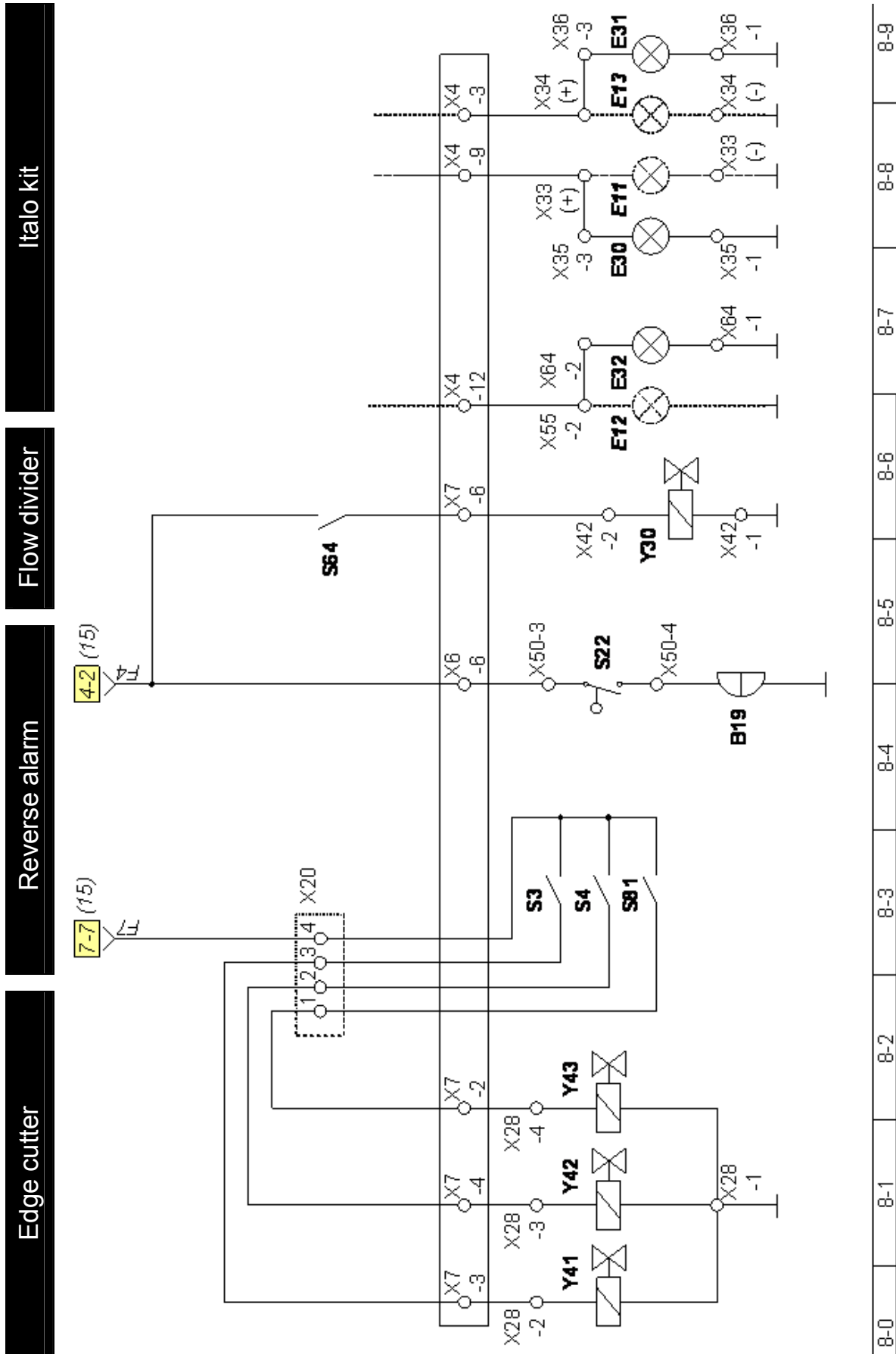



# Wiring diagram (delayed seat switch)

Emergency stop circuit, drive lever zero position, seat contact

Delayed seat contact

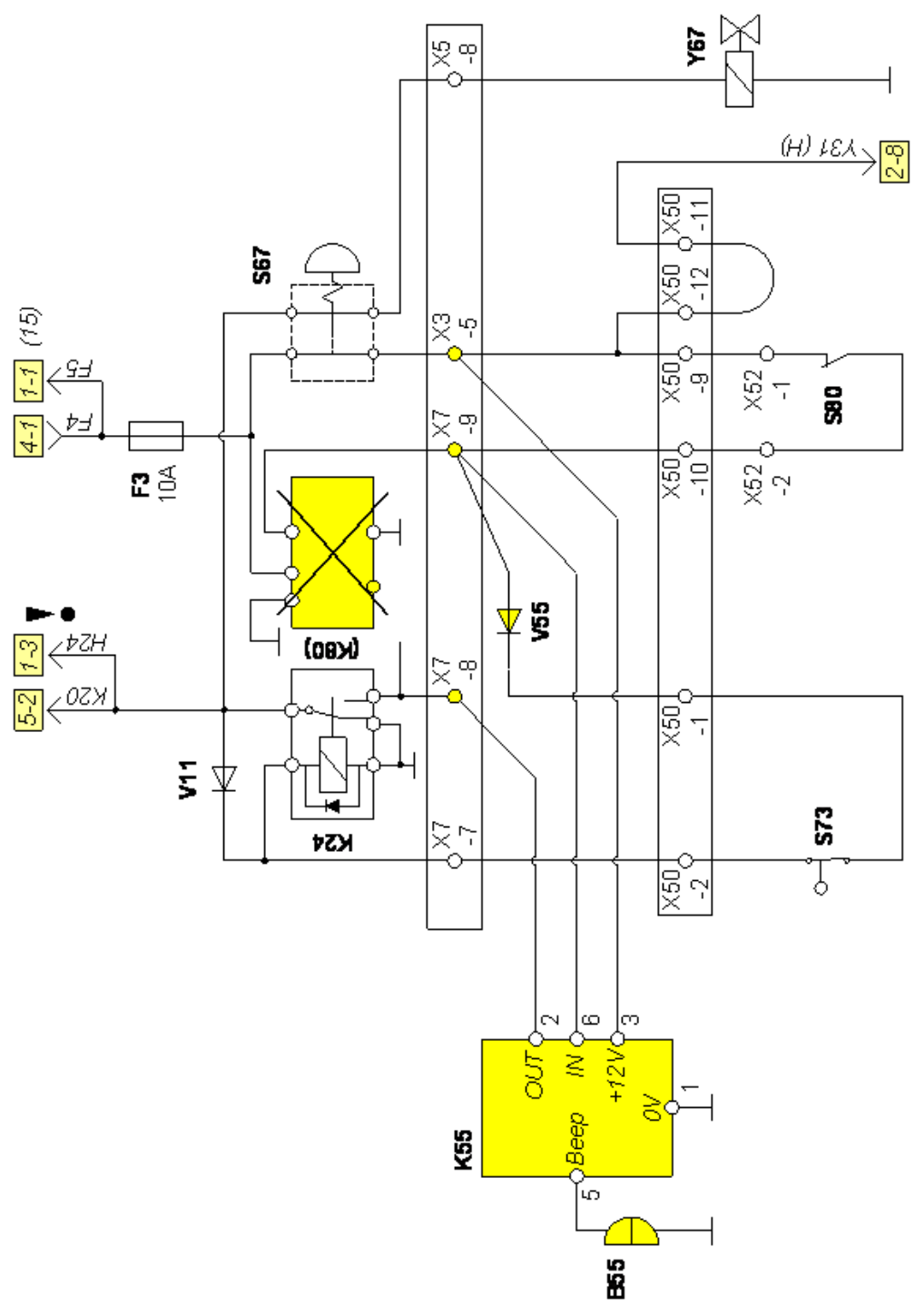

3-0	3-1	3-2	3-3	3-4	3-5	3-6	3-7	3-8	3-9
-----	-----	-----	-----	-----	-----	-----	-----	-----	-----

## Wiring diagram key

---

Element	Description
A1	Fuel display
B3	Horn
B19	Reversing buzzer (*)
B30	Flow divider buzzer (*)
B55	Seat switch seat contact delay buzzer (*)
C80	Capacitor for seat switch
E6	Front left indicator (*)
E7	Rear left indicator (*)
E8	Front right indicator (*)
E9	Rear right indicator (*)
E11	Front left parking light (*)
E12	Rear left parking light (*)
E13	Front right parking light (*)
E14	Rear right parking light (*)
E15	Front left dipped light (*)
E16	Front right dipped light (*)
E21	Revolving warning light (*)
E24	Rear left work light (*)
E25	Rear right work light (*)
E26	Work headlight, left on ROPS (*)
E27	Work headlight, right on ROPS (*)
E30	Front left position light (*)
E31	Front right position light (*)
E32	Number plate light, rear (*)
F1	Parking light fuse
F2	Dipped light fuse
F3	Fuse, emergency stop, holding solenoid
F4	Fuse, sprinkler, horn, reverse alarm, flow divider
F5	Fuse, displays, indicators
F6	Fuse, hazard flasher
F7	Fuse, work headlight, revolving warning light, edge cutter
F11	Fuse, pull-in solenoid

---

## Wiring diagram key

---

Element	Description
F12	Fuse, fan for oil cooler, diesel pump, alternator
F13	Fuse, reserve (15+)
F14	Fuse, reserve
G1	Alternator
G2	Battery
H1	Control lamp, charging control
H2	Control lamp, cooling water temperature
H3	Control lamp, engine oil pressure
H5	Control lamp, pre-heating
H6	Control lamp, parking light
H7	Control lamp, dipped light
H8	Control lamp, indicator
H19	Control lamp, supply pressure (brake pressure)
H24	Control lamp, emergency stop
H36	Control lamp for fuel reserve
K4	Relay, indicator (*)
K14	Relay, starting interlock
K20	Relay, vibration
K24	Relay, emergency stop
K30	Timer relay
K31	Relay, pull-in solenoid
K38	Replay, sprinkler
K55	"Delayed seat switch" timer (*)
K80	Relay, seat contact
M1	Starter motor
M2	Engine, fan for oil cooler
M10	Engine diesel pump
M14	Engine, sprinkler pump
M15	Engine, anti-adhesive pump (*)
P6	Operating hours counter
R1	Sensor, fuel level
R3	Heating coil

---

## Wiring diagram key

---

Element	Description
S1	Battery cut-off switch (*)
S2	Ignition switch
S3	Switch, edge cutter up (*)
S4	Switch, edge cutter down (*)
S6	Sensor (switch), engine oil pressure
S7	Sensor (switch), cooling water temperature
S13	Switch, horn
S14	Switch, hazard flasher (*)
S16	Sensor (switch), oil temperature
S18	Switch, light (parking/dipped light) (*)
S22	Switch, operating lever reverse position
S32	Sensor (switch), supply pressure (brake pressure)
S54	Switch, drive pump zero position
S55	Switch, continuous sprinkling
S56	Switch, work light (*)
S57	Switch, vibration
S58	Switch, indicator left / right (*)
S59	Switch, vibration selector (*)
S60	Switch, beacon light (*)
S61	Switch, interval sprinkler control (*)
S64	Switch, flow divider (*)
S67	Switch, emergency stop
S73	Switch, operating lever neutral position
S76	Switch, sprinkler (button) / anti-adhesive (*)
S80	Switch, seat contact
S81	Switch, edge cutter sprinkler (*)
ST1	Multifunction display unit
V11	Diode, emergency stop (self-latching, emergency stop relay)
V18	Diodes, lock diode, parking position/free-running diode, supply (15+)
V20	Diode, free-running diode, vibration valve
V30	Diode, free-running diode to flow divider (*)

---

## Wiring diagram key

---

Element	Description
V41	Diode, free-running diode to edge cutter valve (*)
V42	Diode, free-running diode to edge cutter valve (*)
V43	Diode, free-running diode to edge cutter valve (*)
V55	Diode, lock diode "delayed seat switch" (*)
X2...X7	Connector on relay panel
X12	Connector, relay panel supply connection
X20	Connector, edge cutter switch connection
X28	Connector, edge cutter diode connection
X40	Connector, edge cutter valve connection
X42	Connector, flow divider valve connection (on AV2 only)
X50	Connector, operating lever console connection
X52	Connector, seat contact connection
Y14	Valve, sprinkler (**)
Y15	Valve, anti-adhesive (**)
Y16	Valve, front vibration
Y17	Valve, rear vibration (*)
Y30	Valve, flow divider (*) (only for AV2-2)
Y31	Stop solenoid; (stop solenoid; pull-in and holding solenoid)
Y41	Valve, edge cutter up (*)
Y42	Valve, edge cutter down (*)
Y43	Valve, edge cutter sprinkler (*)
Y67	Valve, emergency stop (service brake)

(\*) Optional

(\*\*) Not available

---