

OPERATION MANUAL



MODEL AR13H RIDE-ON TANDEM DRUM ROLLER PARALLEL DRIVE SYSTEM (HONDA GX610K1QZB2 GASOLINE ENGINE)

Revision #16 (06/22/21)

To find the latest revision of this publication or associated parts manual, visit our website at:
www.multiquip.com



THIS MANUAL MUST ACCOMPANY THE EQUIPMENT AT ALL TIMES.



CALIFORNIA — Proposition 65 Warning

Engine exhaust and some of its constituents are known to the State of California to cause cancer, birth defects and other reproductive harm.

**MULTIQUIP AR-13H
RIDE-ON TANDEM DRUM
ROLLER**

Proposition 65 Warning 2
 Table Of Contents 3
 Safety Message Alert Symbols 4-5
 Rules For Safe Operation 6-8
 Operation and Safety Decals 9-10
 Specifications (Roller) 11
 Specifications (Engine) 12
 Dimensions 13
 General Information 14-15
 Roller Components 16-18
 Engine Components 19
 Inspection 20-22
 Initial Start-Up 23
 Operation 24
 Maintenance 25-34
 Preparation For Long-Term Storage 35
 Manifold Test Ports 36
 Hydraulic System Diagram 37
 Electric Wiring Diagram (S/N 241001 and Below) 38
 Electric Wiring Diagram (S/N 241002 and Above) 39
 Hydraulic Hose Connections 40-41
 Troubleshooting (Roller) 42
 Troubleshooting (Engine) 43-45

NOTICE

Specification and part number are subject to change without notice.

AR-13H RIDE-ON ROLLER — SAFETY MESSAGE ALERT SYMBOLS

FOR YOUR SAFETY AND THE SAFETY OF OTHERS!

Safety precautions should be followed at all times when operating this equipment. Failure to read and understand the Safety Messages and Operating Instructions could result in injury to yourself and others.

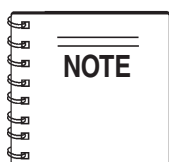

This Owner's Manual has been developed to provide complete instructions for the safe and efficient operation of the Multiquip Model AR-13H Ride-on Tandem Drum

Roller. Refer to the engine manufacturers instructions for data relative to its safe operation.

Before using this roller, ensure that the operating individual has read and understands all instructions in this manual.

SAFETY MESSAGE ALERT SYMBOLS

The three (3) Safety Messages shown below will inform you about potential hazards that could injure you or others. The Safety Messages specifically address the level of exposure to the operator, and are preceded by one of three words: **DANGER**, **WARNING**, or **CAUTION**.

DANGER

You **WILL** be **KILLED** or **SERIOUSLY** injured if you do not follow directions.

WARNING

You **COULD** be **KILLED** or **SERIOUSLY** injured if you do not follow directions.

CAUTION

You **CAN** be injured if you do not follow directions

HAZARD SYMBOLS

Potential hazards associated with operation of the pump will be referenced with Hazard Symbols which appear throughout this manual, and will be referenced in conjunction with Safety Message Alert Symbols. Some examples are listed below:

WARNING - LETHAL EXHAUST GASES



Gasoline engine exhaust gases contain poisonous carbon monoxide. This gas is colorless and odorless, and can cause death if inhaled. **NEVER** operate this equipment in a confined area or enclosed structure that does not provide ample free flow air.

WARNING - EXPLOSIVE FUEL



Gasoline is extremely flammable, and its vapors can cause an explosion if ignited. **DO NOT** start the engine near spilled fuel or combustible fluids. **DO NOT** fill the fuel tank while the engine is running or hot. **DO NOT** overfill tank, since spilled fuel could ignite if it comes into contact with hot engine parts or sparks from the ignition system. Store fuel in approved containers, in well-ventilated areas and away from sparks and flames. **NEVER** use fuel as a cleaning agent.

WARNING - BURN HAZARDS



Engine components can generate extreme heat. To prevent burns, **DO NOT** touch these areas while the engine is running or immediately after operations. **NEVER** operate the engine with heat shields or heat guards removed.

AR-13H RIDE-ON ROLLER — SAFETY MESSAGE ALERT SYMBOLS

WARNING - ROTATING PARTS



NEVER operate equipment with covers, or guards removed. Keep **fingers, hands, hair** and clothing away from all moving parts to prevent injury.

CAUTION - RESPIRATORY HAZARDS



ALWAYS wear approved **respiratory** protection.

CAUTION - ACCIDENTAL STARTING



ALWAYS place the **Engine ON/OFF** switch in the **OFF** position and remove the ignition key when the pump is not in use.

CAUTION - SIGHT AND HEARING HAZARDS

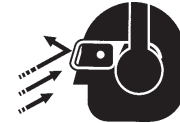

ALWAYS wear approved **eye** and **hearing** protection.

CAUTION - OVER-SPEED CONDITIONS



NEVER tamper with the factory settings of the engine governor or settings. Personal injury and damage to the engine or equipment can result if operating in speed ranges above maximum allowable.

CAUTION - EQUIPMENT DAMAGE MESSAGES

Other important messages are provided throughout this manual to help prevent damage to your concrete pump, other property, or the surrounding environment.

NOTICE

This Ride-on Tandem Drum Roller, other property, or the surrounding environment could be damaged if you do not follow instructions.

RULES FOR SAFE OPERATION

DANGER - Read This Manual!

Failure to follow instructions in this manual may lead to serious injury or even **DEATH!** This equipment is to be operated by trained and qualified personnel only! This equipment is for industrial use only.

The following safety guidelines should always be used when operating the AR-13H Ride-on Tandem Drum Roller:

GENERAL SAFETY

- **DO NOT** operate or service this equipment before reading this entire manual.
- This equipment should not be operated by persons under 18 years of age.
- **NEVER** operate this equipment without proper protective clothing, shatterproof glasses, steel-toed boots and other protective devices required by the job.
- **NEVER** operate this equipment when not feeling well due to fatigue, illness or taking medicine.
- **NEVER** operate this equipment under the influence of drugs or alcohol.
- Whenever necessary, replace nameplate, operation and safety decals when they become difficult read.
- **ALWAYS** check the machine for loosened threads or bolts before starting.
- **ALWAYS** wear proper respiratory (mask) hearing and eye protection equipment when operating the roller.



- **NEVER** operate this equipment when not feeling well due to fatigue, illness or taking medicine.
- **NEVER** operate this equipment under the influence of **drugs** or **alcohol**.



- **NEVER** touch the hot exhaust manifold, muffler or cylinder. Allow these parts to cool before servicing engine or pump.



- **High Temperatures** – Allow the engine to cool before adding fuel or performing service and maintenance functions. Contact with *hot* components can cause serious burns.

- The engine of this roller requires an adequate free flow of cooling air. Never operate the roller in any enclosed or narrow area where free flow of the air is restricted. If the air flow is restricted it will cause serious damage to the roller or engine and may cause injury to people and property. Remember the roller's engine gives off **DEADLY** gases.

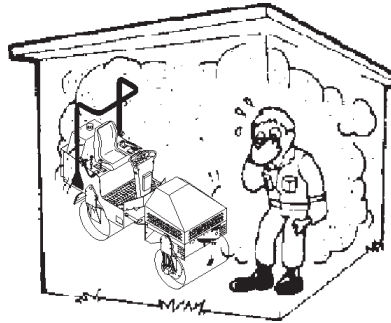

- **ALWAYS** refuel in a well-ventilated area, away from sparks and open flames.
- **ALWAYS** use extreme caution when working with **flammable** liquids. When refueling, **stop the engine** and allow it to cool. **DO NOT** smoke around or near the machine. Fire or explosion could result from fuel vapors, or if fuel is spilled on a hot engine.
- **NEVER** operate the Ride-on Tandem Drum Roller in an explosive atmosphere or near combustible materials. An explosion or fire could result causing severe *bodily harm or even death*.
- Topping-off to filler port is dangerous, as it tends to spill fuel.
- Refer to the **Engine Owner's Manual** for engine technical questions or information.
- **NEVER** use accessories or attachments, which are not recommended by Multiquip for this equipment. Damage to the equipment and/or injury to user may result.
- Manufacturer does not assume responsibility for any accident due to equipment modifications.

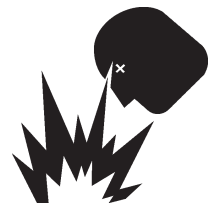

RULES FOR SAFE OPERATION

- **NEVER** Run engine without air cleaner. Severe engine damage may occur.
- **ALWAYS** read, understand, and follow procedures in Operator's Manual before attempting to operate equipment.
- **ALWAYS** be sure the operator is familiar with proper safety precautions and operations techniques before using roller.
- **ALWAYS** store equipment properly when it is not being used. Equipment should be stored in a clean, dry location out of the reach of children.
- **DO NOT** operate this roller with hydrostatic oil temperature higher than 180 degrees fahrenheit.
- **NEVER** leave the roller unattended, turn off engine and place parking brake lever in upright position.
- **CAUTION** must always be observed while servicing this roller. Rotating parts can cause injury if contacted.
- **DO NOT** leave roller with engine running.
- If the roller must be stopped on an incline (grade), remove the ignition key and place chock blocks (not provided) under **the front** and **rear** drums.
- **NEVER** drive the roller on unshored trenches or near steep, unsupported banks. The vibration caused by the roller could cause a cave-in.
- **ALWAYS** use extreme care when operating near obstructions, on slippery surfaces, grades and side slopes.
- **ALWAYS** wear slip resistant safety shoes or boots.
- Unauthorized equipment modifications will void all warranties.
- When working on slopes, avoid **sidehill travel**. Operate up and down travel only. Remember, the danger of sliding on and/or tripping on steep slopes is always present.
- **ALWAYS** wear **seat belts**.
- When malfunctions occur, always remove the ignition key and place a "**DO NOT OPERATE**" sign in the operator's seat.
- If a malfunction occurs with the travel lever mechanism, speed and direction will be impossible to control. Immediately stop the roller and correct the problem.
- If the steering system operates improperly, immediately stop the engine and apply the parking brake.
- In the event of hydraulic hose or line failure, promptly return the travel lever to the "neutral" position, stop the engine and set the parking brake.

MAINTENANCE SAFETY

- **NEVER** lubricate components or attempt service on a running machine.
- **ALWAYS** allow the machine a proper amount of time to cool before servicing.
- Keep the machinery in proper running condition.
- Fix damage to the machine immediately and always replace broken parts, or missing decals.
- Dispose of hazardous waste properly. Examples of potentially hazardous waste are used motor oil, fuel and fuel filters.
- **DO NOT** use food or plastic containers to dispose of hazardous waste.
- **DO NOT** pour waste, oil or fuel directly onto the ground, down a drain or into any water source.

RULES FOR SAFE OPERATION

LOADING AND TRANSPORTING SAFETY

DANGER - Loading & Unloading the Roller

DANGER! ALWAYS load and unload the roller on **Level, Hard Ground, or Pavement**. **Serious injury or death** can result from improper loading, lifting or unloading. Use extreme caution!

- The roller has an operating weight of approximately 3,088 lbs. (1,400 Kg). Use lifting equipment capable of lifting this weight.
- **ALWAYS** check the roller's lifting hooks. Before lifting or transporting the roller, lock the frame with the locking bar that is provided. Make sure the hooks are secure and tight before lifting the machine.
- When driving the roller onto a transporting vehicle or trailer, use ramps or other suitable material of sufficient strength to support the roller.
- Remove mud, oil, ice, snow or any other slippery materials from the ramps and bed of the vehicle to avoid accidents.
- After loading, apply the parking brake.
- Use a chain, binders or other suitable means to firmly secure the roller before transporting.
- Only use the lifting points for the roller that are clearly marked as "**lifting point**".
- **NEVER** apply chains through the articulating section of the roller. The chain could cause damage by scoring the hydraulic steering cylinder.
- **NEVER** stand below roller when it is being lifted.

DANGER - Transporting Safety

DO NOT allow personnel to **stand under** or **near** any suspended machine. **Serious injury or death** may result.

EMERGENCIES

- **ALWAYS** know the location of the nearest **fire extinguisher**.



- **ALWAYS** know the location of the nearest and **first aid kit**.



- In emergencies **always** know the location of the nearest phone or **keep a phone on the job site**. Also know the phone numbers of the nearest **ambulance, doctor** and **fire department**. This information will be invaluable in the case of an emergency.



OPERATION AND SAFETY DECALS

Machine Safety Decals

The AR-13H Ride-on Tandem Drum Roller is equipped with a number of safety decals. These decals are provided for operator safety and maintenance information. The illustration below and on the next page shows these decals as they appear on the machine. Should any of these decals become unreadable, replacements can be obtained from your dealer.

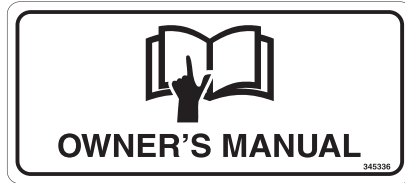

P/N: 34536

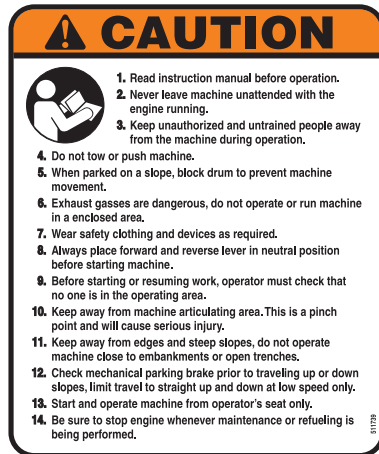

P/N: 511739

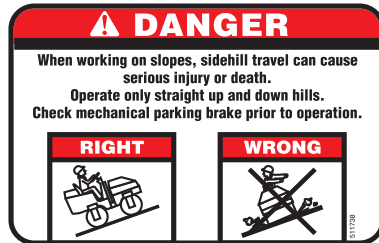

P/N: 511738



P/N: 513740



P/N: 513469



P/N: 511735

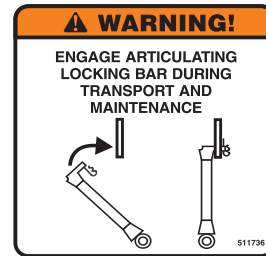

P/N: 511736

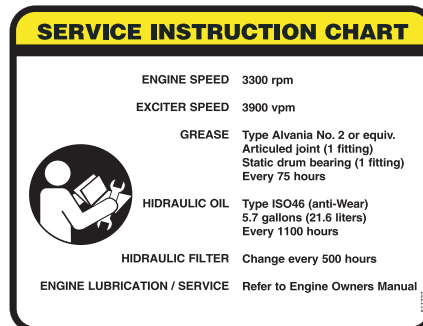

P/N: 511737



P/N: 513529



P/N: 513531

MQ MULTIQUIP

P/N: TBD



P/N: 511724



P/N: 511726



P/N: 513688



P/N: 511733



P/N: 511718

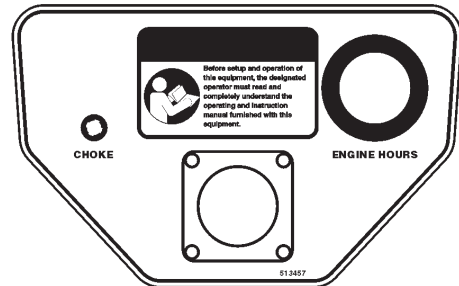

P/N: 513457

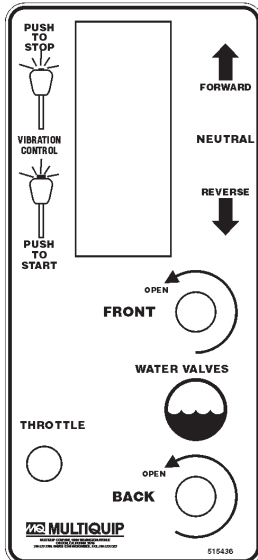

P/N: 515436



P/N: 513393

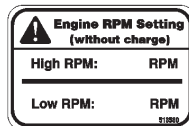

P/N: 513580

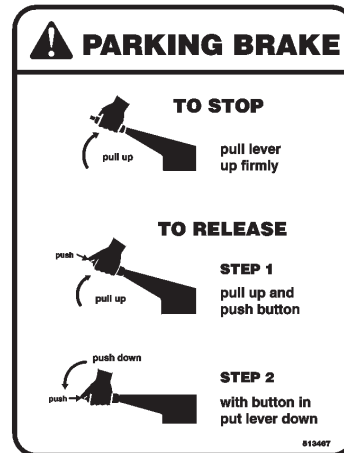

P/N: 513467

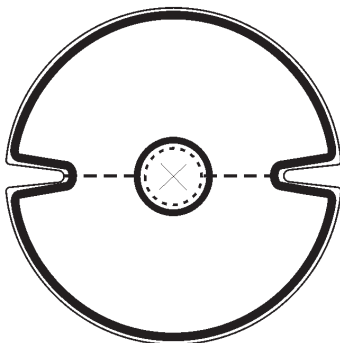

P/N: 513698

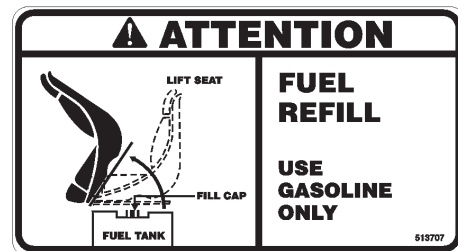

P/N: 513707

AR-13H RIDE-ON ROLLER — SPECIFICATIONS (ROLLER)

Table 1. AR-13H Roller Specifications

Shipping Weight	2,572 lbs. (1,167 Kg.)
Dry Weight	2,428 lbs. (1101 Kg.)
Operating Weight	3,088 lbs. (1,400 Kg.)
Operating Weight w/ Drum Ballast	3,309 lbs. (1,500 Kg.)
Overall Length	86.5 in. (2,197 mm.)
Overall Width	38.25 in. (972 mm.)
Overall Height-ROPS (up)	87 in.(2210 mm.)
Maximum Rolling Width	35.7 in. (907 cm.)
Turning Radius-Inside	109 in. (2,768 mm.)
Ground Clearance	11.5 in. (292 mm.)
Curb Clearance	7.75L, 19.0R (197 mm., 483 mm.)
Wall Clearance	1.75L, 1.25R (45 mm., 32 mm.)
Wheelbase	45 in. (1,143 mm.)
Drum Width	35.7 in. (907mm.)
Drum Diameter	22.6 in. (574 mm.)
Drum Thickness	0.38 in. (10.0 mm.)
Centrifugal Force 2,400 - 2,700 rpm	3,100 Lbs. (1,406 Kg.)
Vibrations per minute 2,400 - 2,700 rpm	4,000 VPM
Dynamic Linear Force per Drum 2,400 - 2,700 rpm	87.5 Lbs./in. (39.6 Kg./cm.) (front only)
Oscillating Angle	11 degrees
Hydraulic Oil Tank Capacity	5.7 U.S. Gallons (21.6 Liters)
Cooling System	Air
Fuel	Gasoline
Fuel Tank Capacity	9.5 U.S. Gallons (36 Liters)
Water Tank Capacity	60 Gallons (227 Liters)
Battery	12 Volt GroupType U1
Travel Speed -variable-	0-4.8 MPH (0-7.7 KPH)
Grade Ability w-w/o Vibration	15 degrees (27%)

AR-13H RIDE-ON ROLLER — SPECIFICATIONS (ENGINE)

Table 2. Engine Specifications

Model	Honda GX610K1QZB2 Engine
Type	Air-Cooled 4 Stroke, Overhead Valve, 2 cylinders (90 degree V-Twin), Gasoline Engine.
Piston Displacement	37.5 cu. in. (614 cc)
[Bore x Stroke]	[3.03 in. x 2.60 in. (77 mm x 66 mm)]
Max. Output	18 hp (13.4 KW, 18.3 PS) at 3,600 rpm
Max. Governed Speed, No Load	3,500 rpm
Max. Torque	31.8 lbf-ft. at 2,500 rpm
Cooling System	Forced Air
Engine Oil	SAE-10W-30 for general use
Engine Oil Capacity (with oil filter replacement)	1.90 qts. (1.80 liters)
Engine Oil Capacity (without oil filter replacement)	1.59 qts. (1.50 liters)
Fuel	Unleaded gasoline
Fuel Consumption	0.51 lb/hph (313 g/kWh, 230 g/PSH)
Spark Plug Type	NGK: ZGR5A DENSO: J16CR-U
Idle Speed	1,400 +/- 150 rpm
PTO Shaft Rotation	Counterclockwise

AR-13H RIDE-ON ROLLER — DIMENSIONS

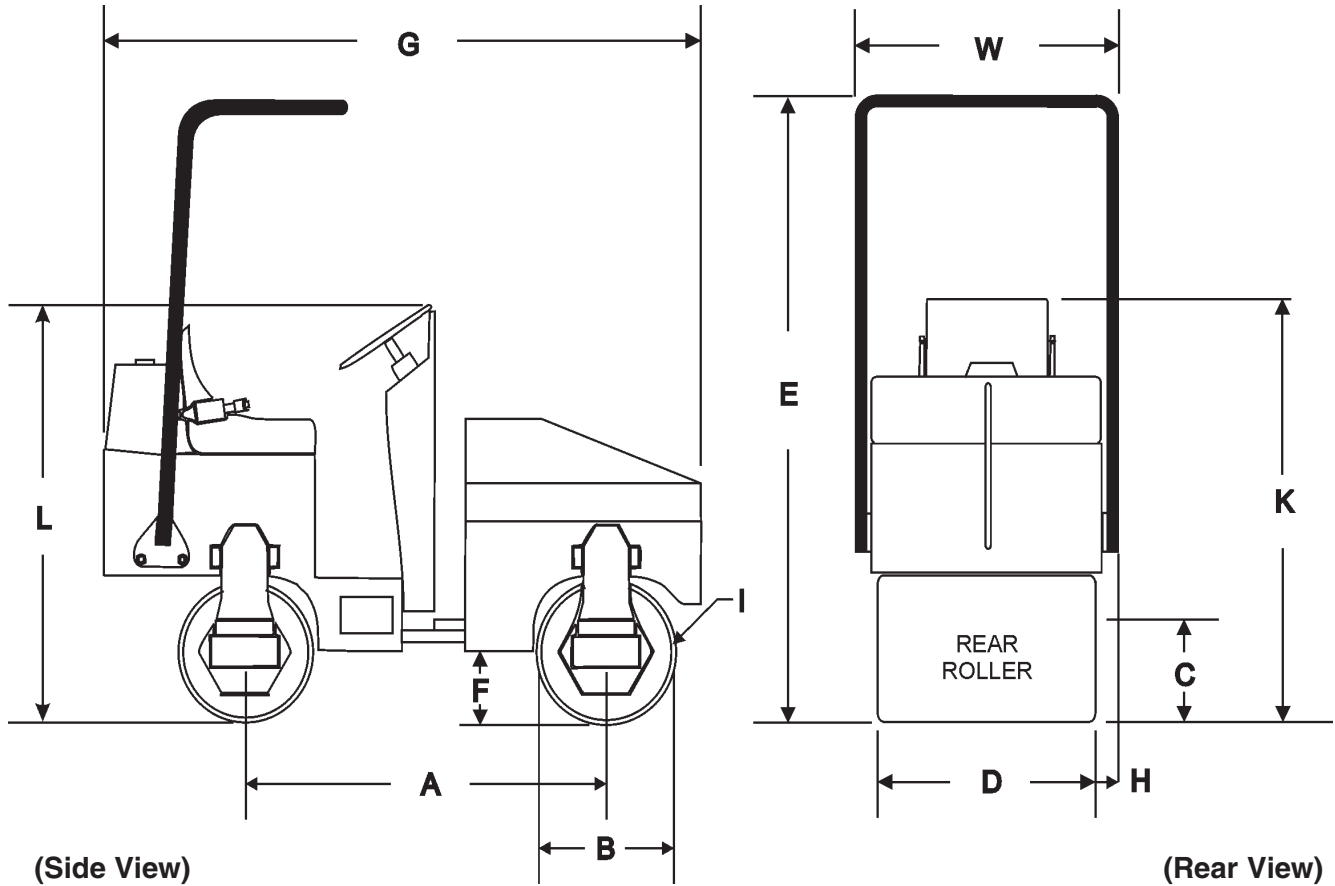

Figure 1. AR-13H Roller Dimensions

Table 3. AR-13 Dimensions		
Wheelbase	A	45.0 in. (1,143 mm.)
Drum Diameter	B	22.6 in. (574 mm.)
Curb Clearance	C	7.75 in. Left, 19.0 in. Right (197 mm., 483 mm.)
Drum Width	D	35.7 in. (907 mm.)
Overall Height (with ROPS)	E	87 in. (2,210 mm.)
Ground Clearance	F	11.5 in. (292 mm.)
Overall Length	G	86.5 in. (2,147 mm.)
Wall Clearance	H	1.75 in. Left, 1.25 in. Right (45 mm., 32 mm.)
Drum Thickness	I	.38 in. (10 mm.)
Overall Width	J	38.25 in. (972 mm.)
Seat Height	K	63 in. (1,600 mm.)
Steering Wheel	L	60 in. (1,524 mm.)

AR-13H RIDE-ON ROLLER — GENERAL INFORMATION

The AR-13H roller has been designed for asphalt application and compaction of granular soils used in site preparation. Use the machine only for the purpose intended and by experienced personnel who understand this operating manual and all safety decals. Typical applications for this roller are driveways, patch work and road repairs. Standard features included with this roller are articulated steering, double drum hydrostatic drive, front drum vibration, high curb clearance and on board water capability.

POWER PLANT

The AR-13H roller is powered by a Honda GX-610, air cooled, gasoline engine rated at 18 hp @3,500 rpm. The engine features a side-mounted muffler designed to direct engine exhaust away from the operator. In the event of low oil, this engine has a built in "**oil alert system**" that will shut-down if the engine oil level reaches an unsafe operating level.

HYDRAULIC SYSTEM

The Honda GX-610 engine drives an axial hydraulics, variable displacement pump which is manually controlled via a cable control system. Pump flow is directed through an aluminum block manifold which provides the control for the 3 hydraulic motors.

The hydraulic drum drive system incorporates a parallel closed loop configuration operating at a maximum pressure of 2,900 psi. In addition this hydraulic system offers a "**free wheel valve**" which allows the roller to be towed in the event of an emergency.

COMPACTION SYSTEM

The compaction force is delivered by a 36-inch wide steel drum with beveled edges to help prevent asphalt **marring**. A fully enclosed hydrostatic drive system offers a variable speed control as well as smooth acceleration and braking.

Connected to the axial hydraulic pump is a gear pump that provides power for the drum vibratory system and the articulating steering system. Oil from this pump flows to the manifold control valve block and then to a hydraulic motor which rotates the eccentric weights inside a sealed housing containing oil to lubricate the bearings.

A pushbutton switch located on top of the gearshift lever when pressed activates a **hydraforce** valve that engages or disengages the vibratory action. The drum's vibratory action generates 3,100 lbs. (1,406 Kg.) of centrifugal force at a frequency of 4,000 vpm (vibrations per minute). If the vibration appears to be weak or slow, allow the machine to warm-up thoroughly, and check the hydraulic oil level. Add hydraulic oil if necessary.

The vibrator housing and drum are shock mounted to isolate the engine compartment and operator from vibration.

The roller nominally has an operating weight of 3,088 lbs (1,400 Kg.), but can be increased to 3,309 lbs (1,500 Kg.) by adding water ballast to the rear drum.

HYDRAULIC OIL FILTER SYSTEM

The hydraulic system oil is filtered by a screen type filter located in the reservoir filler neck, then doubled filtered within the system first by a 40 micron mesh-type suction filter located in the tank and the by a **Zinga** 10 micron, cartridge style spin-on return line filter.

ARTICULATED STEERING SYSTEM

Power for the articulated steering system, which uses a single hydraulic cylinder is provided by the gear pump. This steering system can produce an inside turning radius of 109 inches (2.77 meters).

SPRINKLER SYSTEM

A 60 gallon (227 liters) water tank with a gravity feed spray bar is provided for wetting the roll for asphaltic pavement rolling.

The water system is fully adjustable from the operator's position by adjusting the two water valves. The front valve controls the water supply to the front drum, and the rear valve controls water to the rear drum.

Before starting an asphalt rolling job, be sure all spray bar holes are clear of dirt or foreign matter and are working. Always use clean fresh water in the water tank. To prevent rust and foreign debris from clogging the spray bar holes, drain and flush water tank and spray bars every 30 days.

LIFTING THE ROLLER

When lifting of the roller is required, attach a suitable hook or shackle to the **lifting eye** of the roller. These lifting points (4) are marked by a lifting hook decal. Make sure the lifting device is capable of lifting 4,000 lbs. (1,814 Kg).



DANGER - Clear Obstacles from Area

Before operating the roller, make sure that personnel and obstacles are free from the roller's path. **Serious injury** or even **death** can result!

The forward-reverse control lever operates the hydrostatic pump which governs the roller speed and direction of travel. The speed in which movement of this lever is made is directly related to the amount of pressure that is applied to the travel lever in each direction. Travel speed is infinitely variable from 0 to 4.8 mph. The neutral position of this lever will cause the roller to stop.

AR-13H RIDE-ON ROLLER — GENERAL INFORMATION

! DANGER - Transporting Safety

DO NOT allow personnel to **stand under** or **near** any suspended machine. **Serious injury** or **death** may result.

! CAUTION - Use CERTIFIED Lifting Devices

ONLY! use approved certified lifting devices capable of lifting at least 4,000 lbs. (1,814 Kg.).

! CAUTION - Lifting the Roller

When lifting of the roller is required, only use the provided **lifting eyes** to lift the roller. Using other sections of the roller for lifting purposes may cause severe damage to the roller.

OPERATING ON SLOPES

Special care must be taken when operating the roller on hills or slopes. There exist the possibility of serious injury to the operator and severe damage to the roller in the event of a roll over. **ALWAYS** operate the roller up and down hills rather than from side to side. For safe operation hillside slopes should not exceed 12 degree (27 % grade). See Figure 2 below.

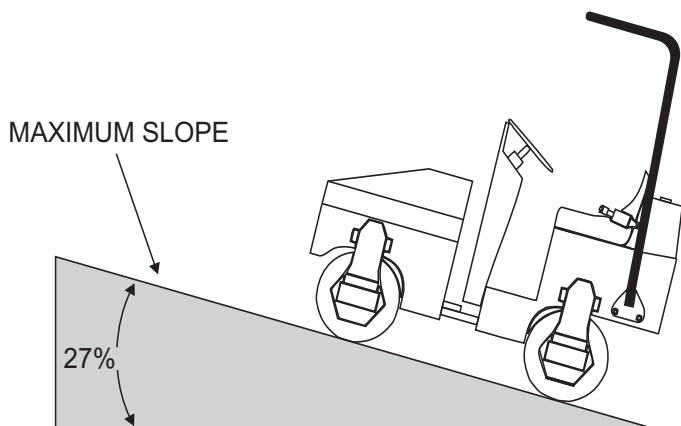

Figure 2. Recommend Slope

Tipping (Rollovers)

NEVER! operate the roller on side slopes (Figure 3). The possibility exist that the roller could tip over (roll over), thus causing bodily harm even death and serious damage to the equipment.

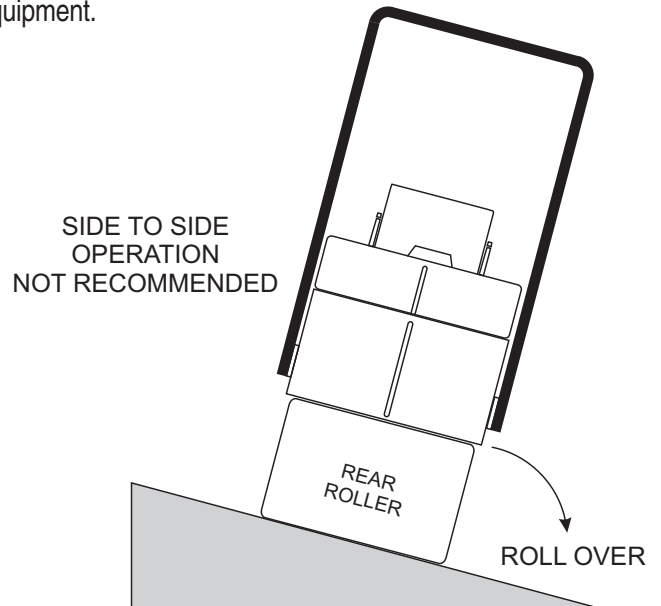

Figure 3. Tipping (Rollover)

NOTICE

NEVER! operate the roller on side slopes. The roller may tip over causing injury to personnel and severe damage to the equipment.

In the event the roller does tip over, if at all possible, try to shut-down the engine by turning the ignition key to the **OFF** position. Extreme care must be taken to prevent damage to the engine. When the roller has been tipped over, oil from the engine crankcase can flow into the combustion chamber, which can severely damage the engine the next time it is started.

IMMEDIATELY after a unit has tipped over upright the unit as soon as possible to prevent oil from leaking into the combustion chamber.

! CAUTION - Roller Rollover Safety

To prevent damage to the engine after a rollover, the roller must **NOT** be started. **NEVER** start a roller after a rollover. **CONTACT** your nearest authorized multiquip dealer for instructions or servicing.

AR-13H RIDE-ON ROLLER — ROLLER COMPONENTS

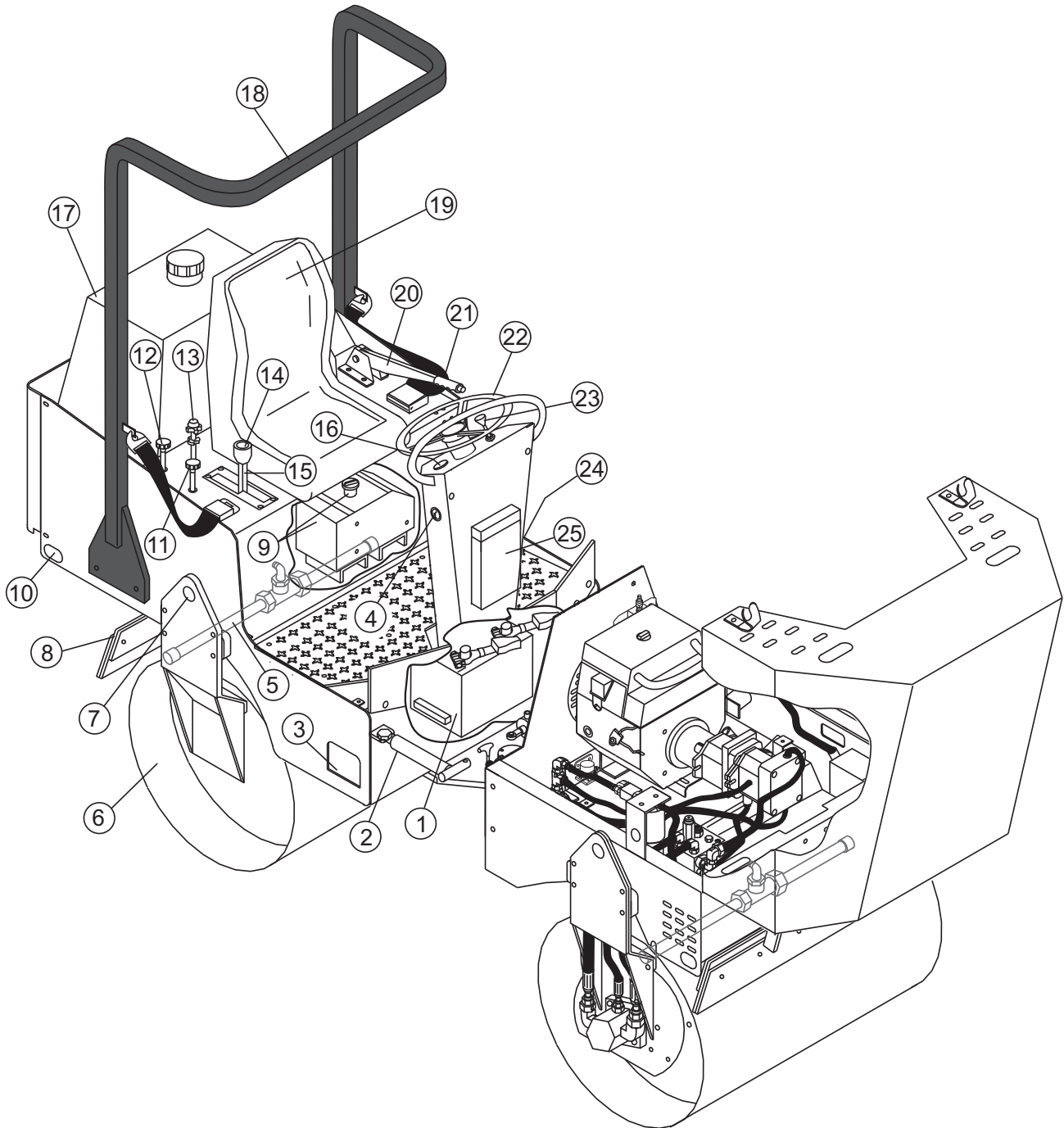
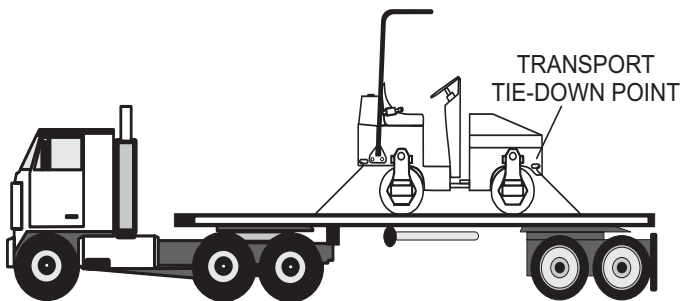

Figure 4. Roller Components 1

AR-13H RIDE-ON ROLLER — ROLLER COMPONENTS

Figure 4 shows the location of the components and basic components for the AR-13H compaction roller. The function of each component or control is described below:

1. **Battery** – Provides +12VDC to the electrical system, and is located underneath foot plate. Replace only with recommended type battery, see specification Table 1.
2. **Articulating Locking Bar** – Always make sure that the articulating locking bar is engaged during lifting, transport and maintenance.
3. **Foot Step** – To lift yourself onto the roller's platform, place foot into foot step, then grab hold of hand rail.
4. **Ignition Switch** – With key inserted, turn clockwise to start the engine.
5. **Rear Sprinkler System** – A gravity feed spray bar is provided for the wetting the roll for asphalt pavement.
6. **Rear Roller** – This roller is a 30 inch wide **steel drum** with beveled edges (no vibration). The beveled edges help prevent asphalt marring.
7. **Lifting Point** – Attach a crane or suitable lifting device to this point when lifting of the roller is required.
8. **Rear Scrapper** – This adjustable rear scrapper blade helps prevent the buildup of material between the drum and frame.
9. **Fuel Tank/Fuel Gauge** – The fuel capacity of the fuel tank is 9.5 gallons (36 liters). Read the gauge on top of the fuel cap to determine if fuel level is low. Fill with unleaded type gasoline. To gain access to the fuel tank, **tilt the front seat forward**. Fuel tank has a spill containment feature
10. **Tie-Down Transport Point** – Attach a chain or suitable tie-down device to this point when transporting of the is required.



11. **Front Spray Control Valve** – This valve controls the flow of water to the **front spray bar**. Turn the water valve to the **open** position (counterclockwise) to let water flow, return this valve to the **closed** position (clockwise) when water is not required.

12. **Rear Spray Control Valve** – This valve controls the flow of water to the **rear spray bar**. Turn the water valve to the **open** position (counterclockwise) to let water flow, return this valve to the **closed** position (clockwise) when water is not required.
13. **Throttle Control** — Pull all the way out to achieved maximum engine RPM's. To idle the engine, push the **RED** stop button inwards all the way.
14. **Vibration Control Button** – Press this button to activate the eccentric that will produce a vibration frequency of 4,400 vpm (vibrations per minute). Pressing the button again will stop the vibrations.
15. **Shift Lever** — Push the lever **forward** to makethe roller travel in a forward direction, pull the lever **backward** to make the roller travel in a reverse direction. Maximum travel speed is 4.8 MPH (7.7 KPH). Center position is neutral, no travel.
16. **Hourmeter** — Indicates the number hours the unit has been in use.
17. **Water Tank** — Remove filler cap and fill with water. Water tank capacity is 60 gallons (227 liters). To determine if water level is low, visually inspect water level gauge (tube) at rear of roller. Add water as necessary.
18. **Roll-Over Bar** — This unit may be equipped with a **Roll Over Protection System** (ROPS option) to protect the operator when the roller is used on slopes, open trenches, sharp turns, slippery surfaces or objects in the rollers's path of travel.
19. **Operator's Seat** — A contoured seat that provides visibility of both front rear drum edges during operation. **NEVER!** start the roller unless seated in the operator's seat.
20. **Parking Break Lever** — Pull the lever upward to set the parking break. To release the parking break, press and hold the button on top of the lever and push lever downward.
21. **Seat Belt** — When using the roller in working conditions always have the operator wear the seat belt. **NEVER** use the roller without a seat belt. If the seat belt becomes worn or damaged, have it replaced immediately.
22. **Steering Wheel** — Use this wheel to steer the roller.
23. **Choke Knob** — Used in the starting of a cold engine, or in cold weather conditions. The choke enriches the fuel mixture.
24. **Hydraulic Motor** – This hydraulic motor provides control for the **rear** of the roller
25. **Documentation Box** — Maintain and store **at all times** Operation, Parts, and Engine manuals in this box.

AR-13H RIDE-ON ROLLER — ROLLER COMPONENTS

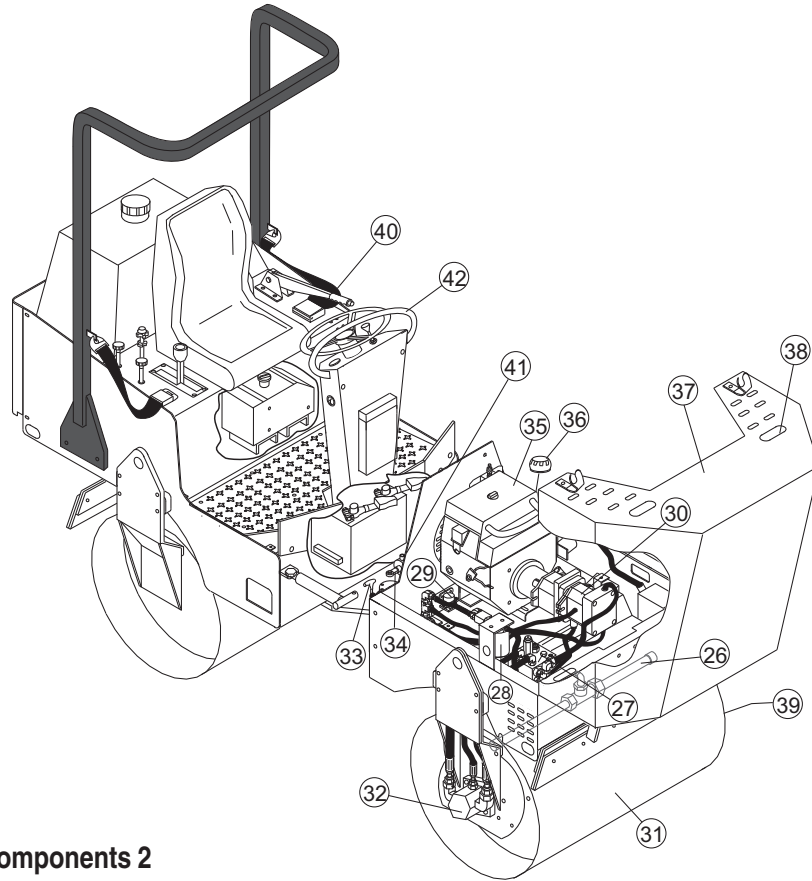

Figure 5. Roller Components 2

Figure 5 shows the location of additional components for the AR-13H compaction roller. The function of each component or control is described below:

- 26. **Front Sprinkler System** – A gravity feed spray bar is provided for the wetting the roll for asphalt pavement.
- 27. **Hydraulic Manifold** – Aluminum block that controls the flow of hydraulic pressure to the various hydraulic motors and other components required to control the roller.
- 28. **Hydraulic Oil Filter** – Filters return oil from the front and rear hydrostatic motors.
- 29. **Accessory Relay** – Provides the +12VDC necessary to run the roller's electrical accessories.
- 30. **Hydraulic Pump** – This unit incorporates an axial variable displacement hydraulic piston pump.
- 31. **Front Ride-on Tandem Drum Roller** – This roller is a 30 inch wide **steel drum** with beveled edges. The beveled edges help prevent asphalt marring.
- 32. **Hydraulic Motor** – This hydraulic motor controls the rotation of the vibratory system.
- 33. **Bunjee Latch** – Pull this rubber latch upward and back to gain access to the engine/pump compartment. There is one rubber latch located on each side of the unit.
- 34. **Steering Cylinder** – Controls direction of roller.
- 35. **Engine** – This unit incorporates a HONDA GX-610, air cooled engine rated at 18 hp at 3,500 rpm.
- 36. **Hydraulic Fluid Filler Port** – Remove this cap to add hydraulic fluid. Fill with type ISO 46 anti-wear hydraulic fluid.
- 37. **Compartment Hood** – Houses the engine, hydraulic manifold, accessory relay, hydraulic oil filter, hoses, and hydraulic pump. To lift the compartment hood, release the rubber bunjee latches located on each side of the hood.
- 38. **Compartment Hood Lift Point** – Place hand here then lift upwards to lift compartment hood.
- 39. **Hydraulic Motor** – This hydraulic motor drives the roller during operation.
- 40. **Rear Drum Zerk Grease Fitting** – Grease this fitting bi-weekly. See maintenance section of this manual.
- 41. **Articulation Zerk Grease Fitting** – Grease this fitting once a year. See maintenance section of this manual.
- 42. **Hand Rail** – Grab hold of this hand rail when lifting yourself onto the operator's platform.

AR-13H RIDE-ON ROLLER — ENGINE COMPONENTS

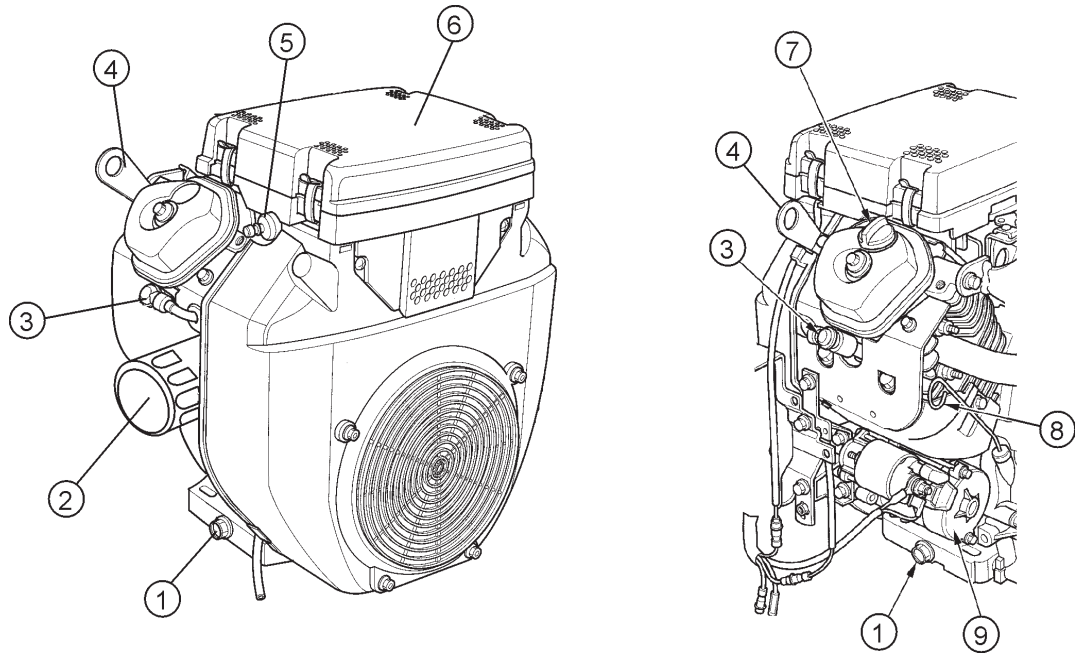

Figure 6. Honda GX610 Engine Controls and Components

INITIAL SERVICING

The engine (Figure 6) must be checked for proper lubrication and filled with fuel prior to operation. Refer to the manufacturer's engine manual for instructions & details of operation and servicing.

1. **Oil Drain Plug** – Remove to drain crankcase oil. Fill with recommended type oil as listed in Table 4.
2. **Oil Filter** – Spin-on type, filters oil for contaminants.
3. **Spark Plug** – Provides spark to the ignition system. Set spark plug gap to 0.6 - 0.7 mm (0.028 - 0.031 inch) Clean spark plug once a week.
4. **Lifting Hook Eye** – Attach a lifting device of adequate lifting capacity at this lifting point whenever lifting of the engine is required.
5. **Fuel Filter** – Prevents dirt and other debris from entering the fuel system..
6. **Air Filter** – Prevents dirt and other debris from entering the fuel system. Unsnap air filter cover to gain access to filter element.

7. **Oil Filler Cap** – Remove to add engine oil.
8. **Oil Dip Stick** – Remove to check amount and condition of oil in crankcase. Refill or replace with recommended type oil as listed in Table 4.
9. **Starter** – Starts engine when ignition key is rotated to the "ON" position.

! WARNING - BURN HAZARD



Engine components can generate extreme heat. To prevent burns, **DO NOT** touch these areas while the engine is running or immediately after operating. **NEVER** operate the engine with the muffler removed.

NOTICE

Operating the engine without an air filter, with a damaged air filter, or a filter in need of replacement will allow dirt to enter the engine, causing rapid engine wear.

AR-13H RIDE-ON ROLLER — INSPECTION

Before Starting

1. Read safety instructions at beginning of manual.
2. Clean the **ROLLER**, removing dirt and dust, particularly the engine cooling air inlet, carburetor and air cleaner.
3. Check the air filter for dirt and dust. If air filter is dirty, replace air filter with a new one as required.
4. Check carburetor for external dirt and dust. Clean with dry compressed air.
5. Check fastening nuts and bolts for tightness.



3. Check the oil level shown on the dipstick (Figure 8).

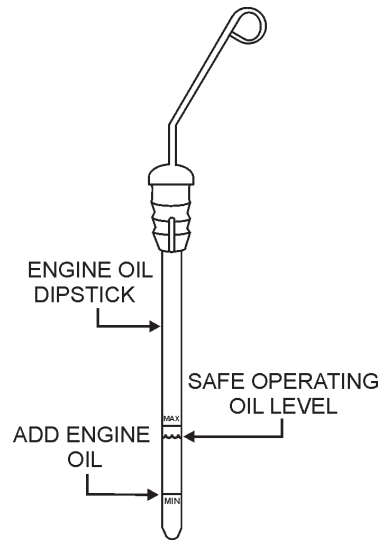

Figure 8. Engine Oil Dipstick Level

Engine Oil Check

1. To check the engine oil level, place the roller on secure level ground with the engine stopped.
2. Remove the dipstick from its holder (Figure 7) and wipe it clean.

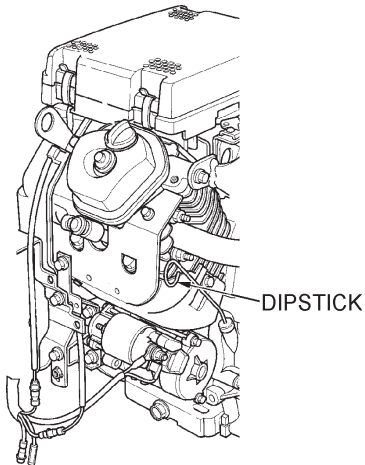

Figure 7. Engine Oil Dipstick (Removal)

4. If the oil level is low, remove the oil filler cap (Figure 9) and fill to the safe operating level (max) as indicated by the dipstick. Fill with recommended type oil as listed in Table 4. Maximum oil capacity is 1.90 quarts (1.8 liters).

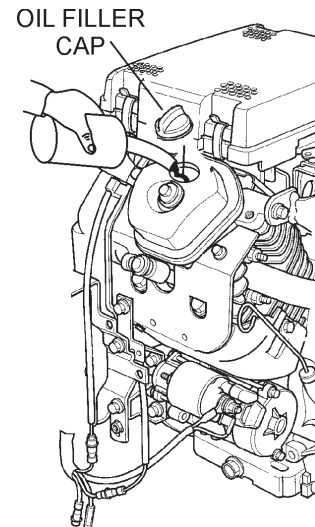

Figure 9. Engine Oil Filler Port

Table 4. Motor Oil Grade

Season or Temperature	Grade of motor oil (higher than MS class)
Spring, Summer or Autumn +120° F to +15° F	SAE 30
Winter +40° F to +15° F	SAE 30
Below +15° F	SAE 10W-30

NOTICE

The **HONDA GX-610** engine used on the AR-13H roller has an "**Oil Alert System**". This system will automatically stop the engine in the event of low oil level. **ALWAYS** be sure to check the engine oil level prior to starting the engine.

AR-13H RIDE-ON ROLLER — INSPECTION

Fuel Check

! DANGER - EXPLOSIVE FUEL

NEVER fill the fuel tank while the engine is running or in the dark. Fuel spillage on a hot engine can cause a fire or explosion. If fuel spillage occurs, wipe up the spilled fuel completely to prevent fire hazards.



DO NOT smoke while refueling, motor fuels are highly flammable and can be dangerous if mishandled.

1. To check the engine fuel level, place the roller on secure level ground with the engine stopped.
2. Tilt the operator's seat (Figure 10) **forward** to gain access to the fuel tank.

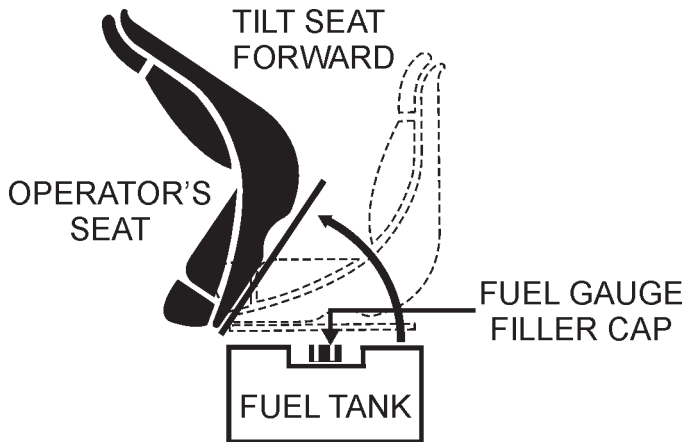

Figure 10. Fuel Tank Access

3. Read the fuel gauge (Figure 11) located on top of the fuel tank to determine if fuel level is low.



Figure 11. Fuel Gauge

4. If the fuel level is low, remove the fuel filler cap/gauge and fill with unleaded gasoline. Wipe up any spilled fuel immediately.
5. Pay attention to the fuel tank capacity when replenishing fuel (Figure 12). Refer to the fuel tank capacity listed on page 13, AR-13H Roller Specification Table 1.

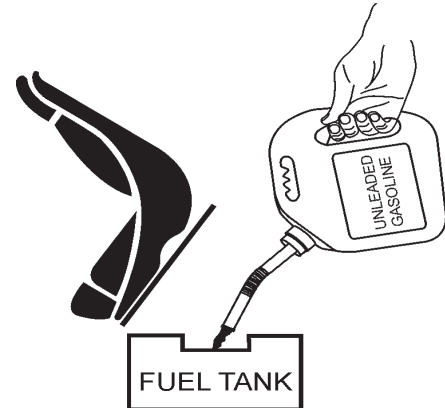

Figure 12. Adding Fuel

6. After replenishing fuel, make sure fuel cap is securely tighten to fuel tank. Return operator's seat to normal operating position.

Hydraulic Oil Check

1. To check the hydraulic oil level, place the roller on secure level ground with the engine stopped.
2. Visually inspect the hydraulic oil sight glass (Figure 13) located on the right rear of the front drum. For normal operation the hydraulic oil level must be below the top and above the bottom of the sight glass. **DO NOT OVERFILL!**

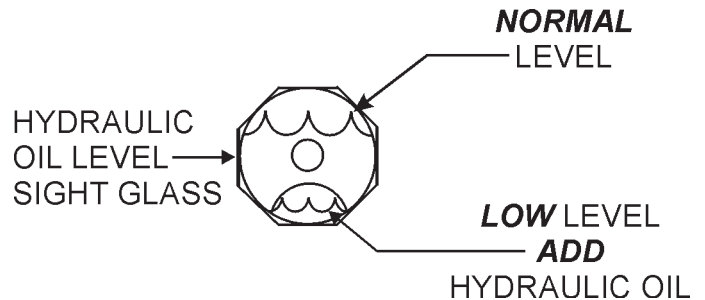

Figure 13. Hydraulic Oil Sightglass

4. If the hydraulic oil level is low, remove the hydraulic oil cap (Figure 14) and fill with type **ISO 46 anti-wear type hydraulic oil** to the recommended operating level.

AR-13H RIDE-ON ROLLER — INSPECTION

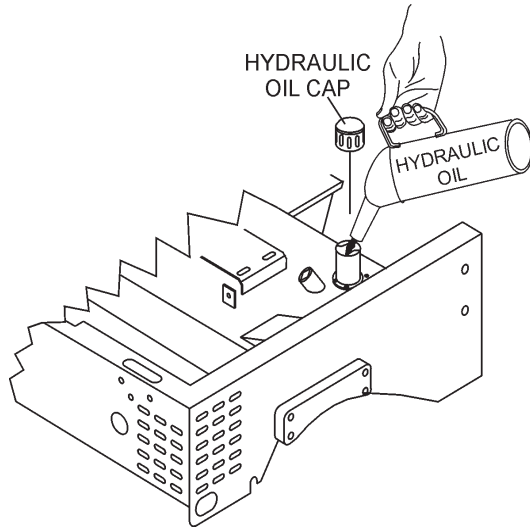

Figure 14. Hydraulic Oil Reservoir Filler Port

Battery Check

A 12-volt DC battery (Figure 16) is shipped dry, and will require a proper electrolyte level for operation.

ALWAYS be sure that the battery cables are properly connected to the battery terminals as shown below. Generally the **RED** cable will be connected to the positive terminal of the battery, and the **BLACK** cable will be connected to the negative terminal of the battery.

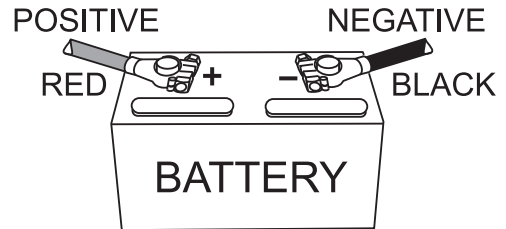

Figure 16. Battery

Water Tank Check

1. To check the water tank water level, place the roller on secure level ground.
2. The amount of water inside the water tank can be visually inspected by reading the water tube (Figure 15) that runs vertically along the water tank at the rear of the roller. This tube indicates the amount of water inside the water tank. Total tank capacity is 60 gallons (227 liters)

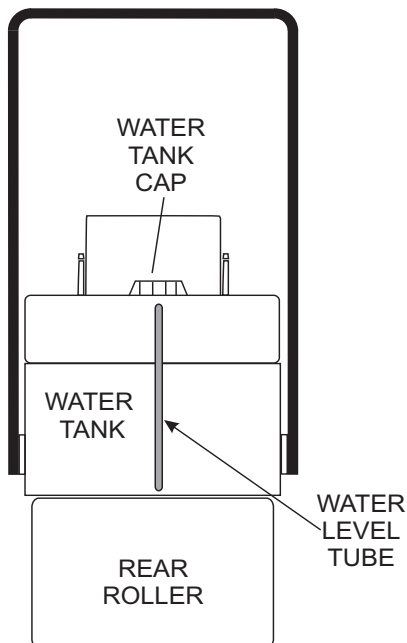

Figure 15. Water Tank

! WARNING - Battery Polarity Safety

If the battery cables are connected incorrectly, electrical damage will occur causing damage to the roller's electrical circuits. Pay close attention to the polarity of the battery when connecting the battery.

AR-13H RIDE-ON ROLLER — INITIAL START-UP

Initial Start-up Instructions

Starting

CAUTION - General Operation Safety

DO NOT attempt to operate the roller until the Safety, General Information and Inspection sections have been read and understood.

1. Place your foot into the roller's foot step, grab hold of the hand rail located on the steering console, and lift yourself onto the platform.
2. Sit down in the operators seat and adjust the seat for a comfortable position, then fasten the seat belt (Figure 17) around your waist. **NEVER!** operate the roller without the seat belt being fastened, serious injury could occur if the seat belt is not used.

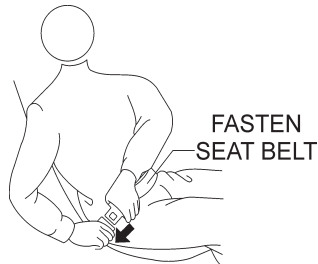

Figure 17. Securing Seat Belt

3. Before starting engine, make sure the immediate area is free of obstructions and debris that may lay in the roller's path.
4. Make sure that the roller's shift lever (Figure 18) is placed in the **neutral position**.

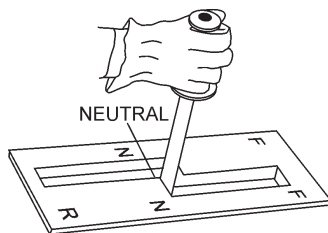

Figure 18. Shift Lever

5. In cold weather, start the roller with the choke fully **closed**. In warm weather or when the engine is warm, the roller can be started with choke halfway or completely **open**.
6. **PUSH** the "RED" button (Figure 19) on the throttle control and pull the round black knob about halfway out. Make sure that the throttle lock knob has been dis-engaged.

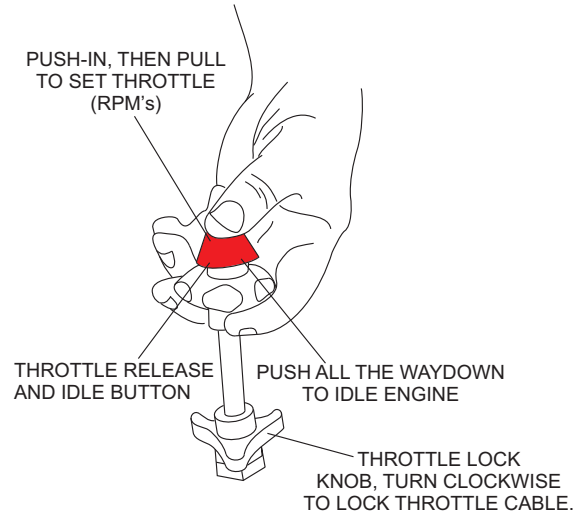

Figure 19. Throttle Control

7. Insert the ignition key into the ignition (Figure 20), then turn and hold the key in the clockwise position until the engine starts, release key.

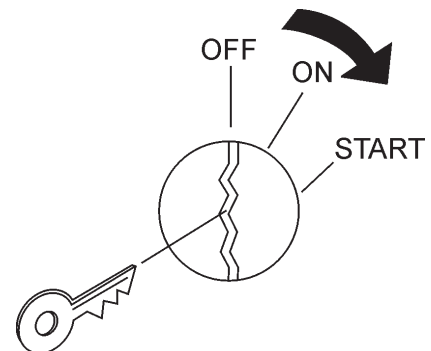

Figure 20. Ignition Switch

8. If the engine does not start, repeat steps 1 through 7 or consult the troubleshooting guide contained in this manual.
9. Let the engine warm for 3 to 5 minutes before using roller. Check for fuel and oil leaks, and noises that would associate with a loose guard and/or covers.
10. If necessary return the choke knob to the full **OPEN** position.

NOTICE

The **CLOSED** position of the choke knob enriches the fuel mixture for starting a **COLD** engine. The **OPEN** position provides the correct fuel mixture for normal operation after starting, and for restarting a warm engine.

AR-13H RIDE-ON ROLLER — OPERATION

OPERATION

Parking Brake

1. To release the parking brake, press and hold the release button (Figure 21) pull up slightly on the parking lever, then push the parking brake lever all the way down.

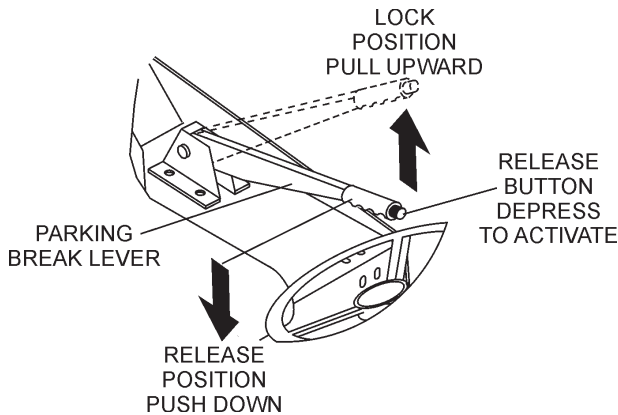

Figure 21. Brake Release Lever

Shift Lever

1. To make the roller move in a **forward direction**, move the shift lever forward as shown in Figure 22.

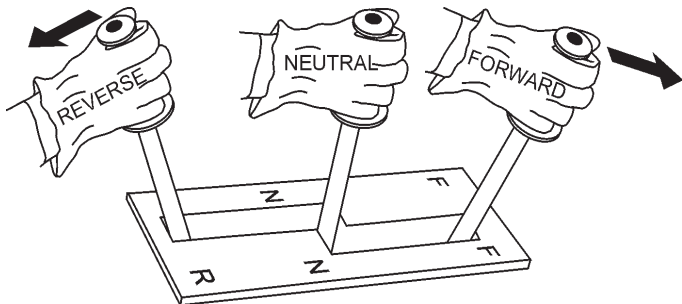

Figure 22. Shift Lever

2. Remember the speed of the roller is directly proportional to the amount of pressure being applied to the lever in each direction. Travel speed is between 0 and 4.8 mph (7.2 kph).

CAUTION - Drive System Safety

ALWAYS allow the roller to come to a complete stop before changing the direction of travel. Changing directions before the roller comes to a complete stop will result in **excessive force** being applied to the transmission and drive system, which will reduce the over service life of the system.

3. Try maneuvering the roller a few times to get familiar with the handling. Also place the travel lever in the opposite direction to get acquainted with driving in reverse.
4. Make sure that the roller comes to a complete stop (neutral) before placing the travel lever in either a forward or reverse position.

Vibration Button

1. To begin the vibratory action, **press** the vibratory pushbutton switch located on top of the travel lever as shown in Figure 23. The pressing of this switch will generate 3,100 lbs. (1,406 Kg.) of centrifugal force at a frequency of 4000 vpm (vibrations per minute) to the **front** drum.

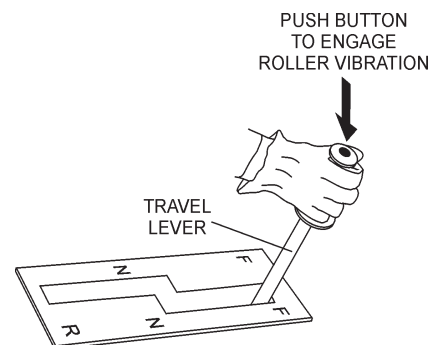

Figure 23. Vibration Pushbutton Switch

2. To stop the vibratory action, press the vibratory pushbutton switch again.

Sprinkler Controls

1. If the application requires the wetting of a surface, front and rear drum sprinkler controls have been provided. These controls (Figure 24) are located to the bottom right of the operators seat. The **front** valve controls the water supply to the front drum spray bar and the **back** valve controls water flow to the back drum spray bar.

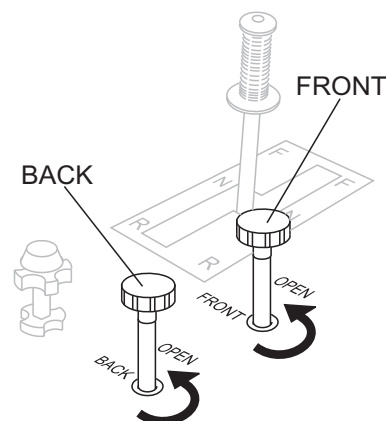

Figure 24. Sprinkler Controls

AR-13H RIDE-ON ROLLER — MAINTENANCE

Maintenance

Perform roller maintenance as indicated by Figure 25 and Table 5.

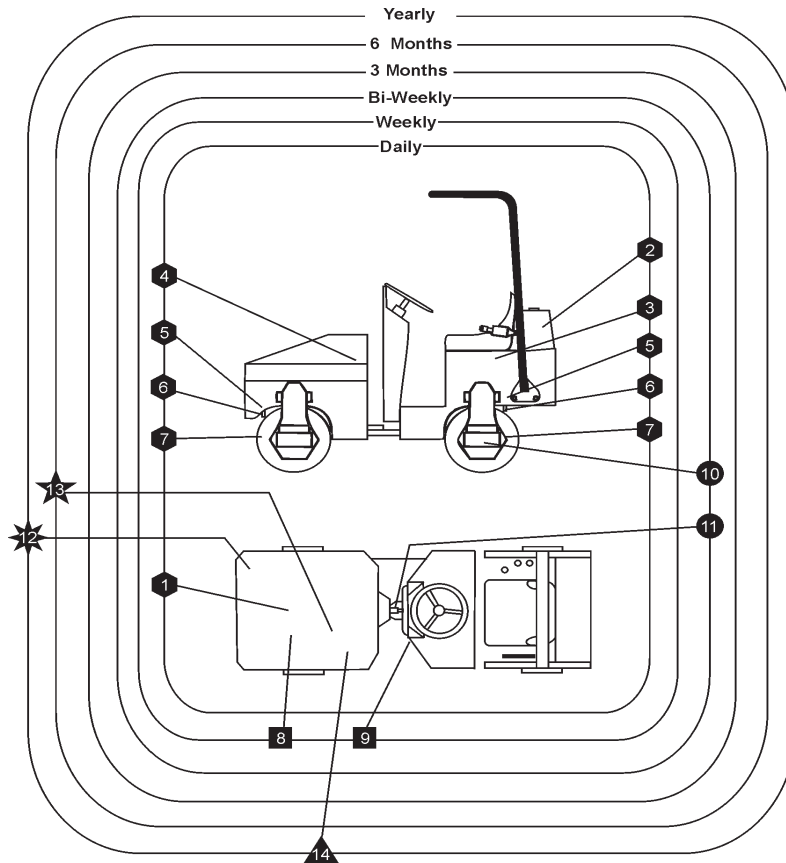

Figure 25. Roller Maintenance Schedule

Table 5. AR-13H Roller Maintenance Schedule

	Daily	1	2	3	Interval	Notes
1	Engine Oil Level	X	X			See Table 4
2	Water Tank Level	X	X			
3	Fuel Level	X	X			
4	Hydraulic Oil Level	X	X			Use ISO 46 Type Hydraulic Oil
5	Sprinkler System	X				
6	Scraper	X	X			Replace when badly worn
7	Drums (Front/Rear)	X	X			
Weekly						
8	Air Filter	X	X			Replace paper element once a year.
9	Battery Liquid Level	X	X			
Bi-Weekly						
10	Zerk Grease Fitting (Rear Drum)		X		80 hrs. or Bi-Weekly	Use Type Alvania #2 or equivalent 3 shots max. DO NOT over grease.
11	Zerk Grease Fitting (Articulation Joint)		X		80 hrs. or Bi-Weekly	Use Type Alvania #2 or equivalent 3 shots max. DO NOT over grease.
3 Months						
12	Hydraulic Oil Filter (Return)			X	500 hrs.	Replace with same type filter.
6 Months						
13	Engine Oil Filter			X	20 hrs. or 1 month	After first 20 hrs, change oil filter every 6 months or 100 hrs.
Yearly						
14	Hydraulic Oil			X	1,100 hrs. or Once a year	Use ISO 46 Type Hydraulic Oil

1 = Check 2 = Refill/ Clean / Grease 3 = Replace

AR-13H RIDE-ON ROLLER — MAINTENANCE

Hydraulic Oil System

The hydraulic system consists of a two pump stack directly coupled to the engine. A hydraulic valve block (manifold) is provided for quick and easy testing and troubleshooting.

Hydraulic oil is filtered by a screen filter located in the tank filler neck, a **40 micron suction filter** located in the tank, and a **10 micron return filter**, with cold oil bypass valve located in the return circuit.

It is recommended that **ISO 46 type hydraulic oil** or equivalent be used when adding or replacing the hydraulic oil is required.

DO NOT USE MULTI-VISCOSITY OIL. Cleanliness is a very important part of proper hydraulic system operation. Hydraulic oil is not only used to transfer power; it also lubricates and cools the system components. Keeping the hydraulic system clean can help reduce costly repairs.

The hydraulic oil level sight glass is located on the right rear of the front drum, below the engine compartment. This level should be checked daily. Oil must be below the top and above the bottom of the sight glass. **DO NOT OVERFILL!** Care should be taken to clean the filler cap before adding oil to the system. If hydraulic oil has to be added, the machine should be inspected for leaks.

The **suction filter** (Figure 26) is located inside the hydraulic tank. This filter is attached to the fitting connected to the hydraulic pump suction hose.

The **return filter** (Figure 26) is located at the front of the engine compartment. Replace both filters according to the Table 5.

CAUTION - HYDRAULIC SYSTEM HAZARD

DO NOT open hydraulic lines or loosen hydraulic fittings while engine is running! Hydraulic fluid under pressure can penetrate the skin, blind, cause burns or create other potentially dangerous hazards follow all safety instructions as described throughout this manual.

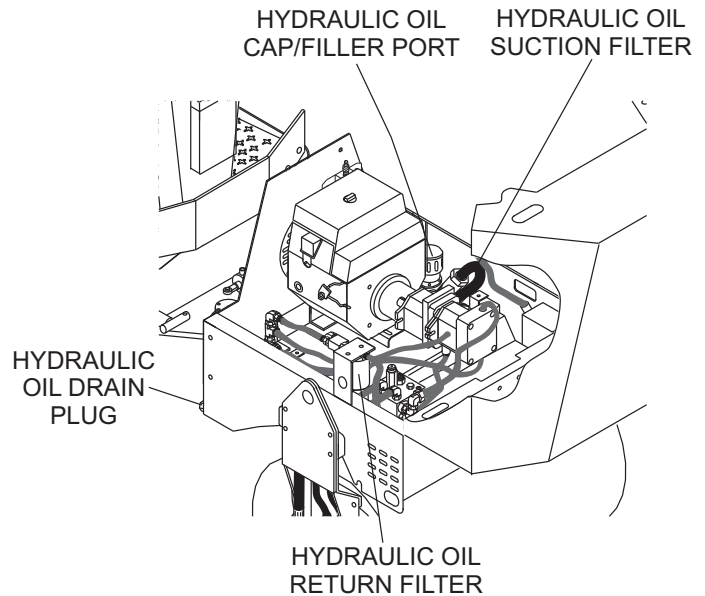

Figure 26. Hydraulic Filter Locations

Changing Hydraulic Oil and Filters

1. Park the roller on a clean flat work area and set the parking brake.
2. Remove the **hydraulic oil drain plug** (Figure 26) and drain the hydraulic oil. Dispose of the used oil in an environmentally friendly manner. Replace the drain plug and tighten.
3. Remove the return filter and **install a new filter**. Dispose of the used filter in an environmentally friendly manner.
4. Disconnect the suction hose and remove the fitting from the tank. **Replace** the suction filter. Dispose of the used filter in an environmentally friendly manner. Replace the fitting and reconnect the suction hose.

Freewheel Engagement Valve

This hydraulic system has a freewheel engagement valve allowing hydraulic oil to be bypassed. **Open** (turn allen wrench counter-clockwise) this valve (Figure 27) to engage the freewheel capability of the roller. When the valve is fully opened, ports **A** and **B** are allowed to connect, bypassing the oil to and from the drum drive motors.

Remember the freewheel engagement valve should only be used in emergencies when the roller cannot be driven due to engine or hydraulic system problems.

When towing of the roller has been completed, this valve **must** be **closed** (turn allen wrench fully clockwise) completely and the lock nut set. Failure to close this valve completely will result in low power, improper speed, and excessive hydraulic oil temperature.

AR-13H RIDE-ON ROLLER — MAINTENANCE

CAUTION - Freewheel Engagement Valve

The freewheel engagement valve (towing) is only for **emergency use**. **DO NOT** move roller over 2 MPH or long distances as hydraulic system component failure could result.

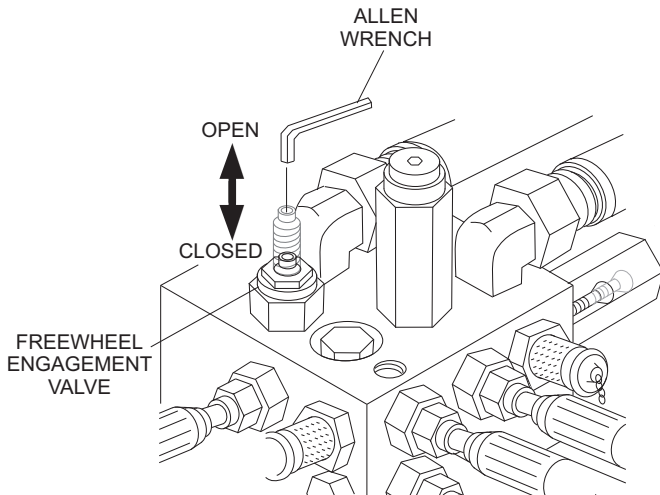

Figure 27. Freewheel Engagement Valve

Drum Drive

The drum drive circuit is a **parallel, closed loop system** (Figures 29 and 30) consisting of a hydrostatic pump, two relief valves, a freewheel engagement valve, front and rear drum drive motors.

The hydrostatic pump is manually controlled by a cable connected to the forward/reverse shift lever located on the right side of the operator seat. When the shift lever is placed in forward, high-pressure oil is supplied by the hydrostatic pump to the valve block (**port A**). The valve block (manifold) directs this high-pressure oil to the front and rear drum drive motors. Return oil from the motors is returned to the valve block (**port B**) and is returned to the suction side of the hydrostatic pump.

When shifted into reverse, the high-pressure and suction ports on the hydrostatic pump are reversed. Oil flow is then in the opposite direction of forward (**port B** becomes high-pressure and **port A** becomes suction)

Vibration and Steering

The vibration and steering system is an **open loop circuit** operated by a gear type pump. Separate relief valves control each circuit. This system consist of the gear pump, relief valves, electric vibration control valve, vibration drive motor, steering valve, and steering cylinder.

The vibration circuit is controlled by an electric control valve located on the valve block (manifold). This valve is controlled by the **“ON/OFF”** pushbutton switch mounted on top of the travel lever.

High-pressure oil is supplied by the pump to the valve block (**port P**) and is directed to the electric control valve. When the pushbutton switch is in the **“OFF”** position, this valve is **open** allowing oil to go to the steering valve, without driving the vibration motor.

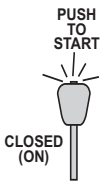

When the switch is in the **“ON”** position, the electric control valve **closes** and oil is directed out of **port 1** to the vibration motor. Return oil from the motor returns to the valve block via **port 2** and is directed to the steering valve.

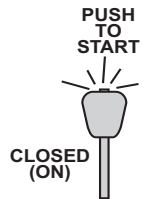

Steering is controlled by a **steering valve** and **cylinder** (Figures 29 and 30). The steering wheel is direct coupled to the steering valve controlling the oil flow to the cylinder. Oil supplied from the vibration circuit is directed to **port 3** which connects to **port P** of the steering valve. When steering is not being used, oil passes out of **port T** of the valve block and returns to the hydraulic tank. When the steering wheel is operated, the steering valve closes and oil is directed to ports **L** or **R** to extend or retract the steering cylinder.

Rubber Scrapper Mat

Rubber scrapper mats have been provided for the cleaning of the front and rear drums. Adjust the scrapper mats as close as possible to the drums, using the slotted holes (Figure 28) provided. Replace these rubber mats when they become badly worn.

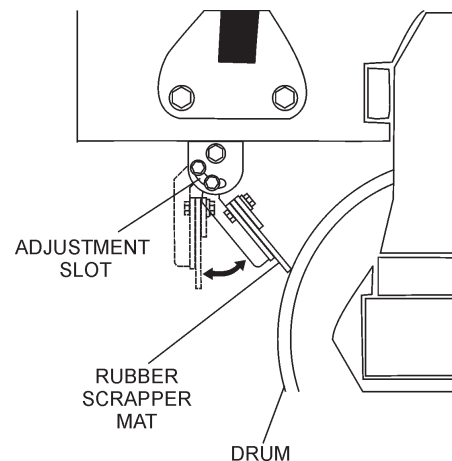

Figure 28. Scrapper Bar Adjustment

AR-13H RIDE-ON ROLLER — MAINTENANCE

Forward/Reverse Hydraulic Pressure Test

Park the machine on a solid flat surface and stop the engine. Set the parking brake and **block the front drum securely**.

1. Check hydraulic oil level by viewing the hydraulic oil sight glass. The hydraulic oil level must be below the top and above the bottom of the sight glass. **DO NOT OVERFILL!**
2. Adjust engine RPM (3,500 +/- 50 RPM)
3. Let engine run for 5 minutes, this will bring the hydraulic oil operating temperature to a minimum of 135° fahrenheit.
4. Check and repair all hydraulic leaks.
5. On the manifold block install a 5,000 psi pressure gauge (Figure 34) to the **forward** pressure quick disconnect test port 2
6. Run engine at full throttle.
7. Move the **travel lever** to the forward position. **MAKE SURE FRONT AND REAR DRUMS DO NOT SPIN.**
8. Read the pressure gauge. The **relief pressure** (roller drums blocked) will read 2,900 ± 145 psi. Under **normal operating** conditions this pressure will read 400-600 psi.
9. Return the travel lever to the **neutral** position and **stop** the engine.
10. Install the pressure gauge into the reverse quick disconnect **port 3** and repeat the above procedures. The relief pressure reading for the **reverse** test port 3 will be the same (2,900 psi). Again normal operation pressure for the reverse port will be 400-600 psi.

Vibration Circuit Pressure Test

Place the front drum on soil, gravel, or a heavy rubber mat. **DO NOT ACTIVATE VIBRATION FEATURE ON CONCRETE OR HARD SURFACE!**

1. On the manifold block install a 5,000 psi pressure gauge to quick disconnect test port 1.
2. Start the engine and run at full throttle.
3. To start the vibration, **press** the pushbutton switch (vibration control) located on top of the travel lever. Under normal operating conditions this pressure will range between 800-1,000 psi.

NOTICE

Vibration relief pressure is hard to read accurately using this test. It may be necessary to disconnect the pressure line to the vibration drive motor. Plug this line and re-test, pressure will be exact relief pressure. **DO NOT** perform this test for a long period of time — damage could occur.

Steering Pressure Test

1. On the manifold block, install a 5,000 psi pressure gauge into quick disconnect test **port 1** (Figure 34).
2. Start the engine and run at full throttle.
3. Turn the steering wheel to the **left or right** (maximum) and hold. Read the steering relief pressure. The **relief pressure** reading for the **steering** test port 1 will be 700 psi. Again, under normal operating conditions, pressure for the steering port will be between 200-400 psi.

If maximum pressure cannot be reached, plug the steering cylinder pressure hoses and re-test. If pressure is correct the steering cylinder is leaking. **DO NOT ACTIVATE THE VIBRATION FUNCTION WHILE PERFORMING THIS TEST !**

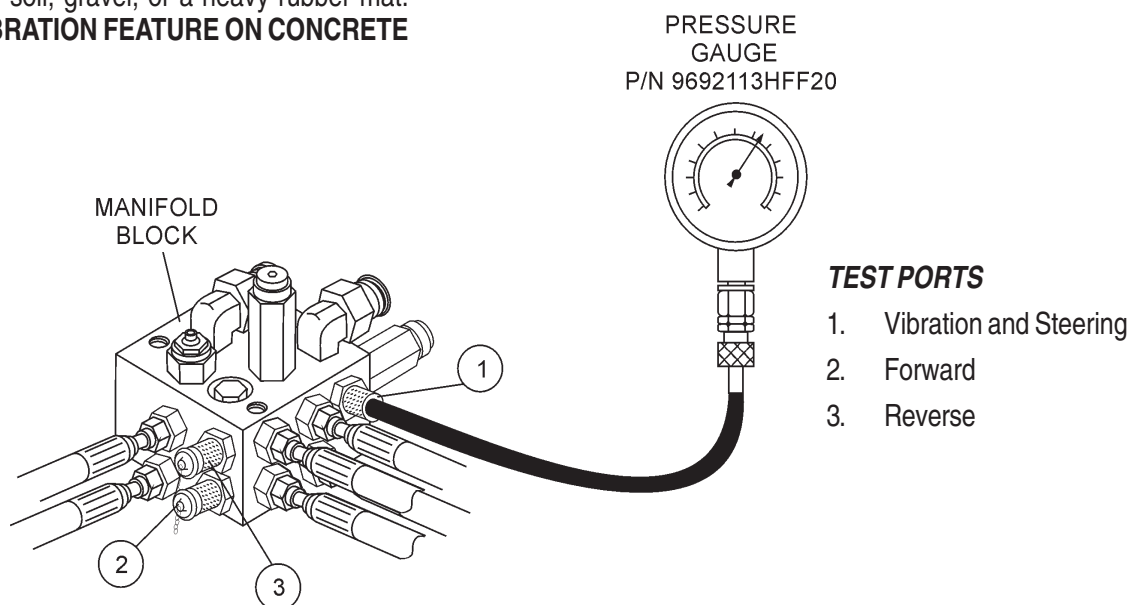

Figure 34. Manifold Test Ports

AR-13H RIDE-ON ROLLER — MAINTENANCE

Forward/Reverse Relief Valves Drive Adjustment

The **forward** and **reverse** relief valves (Figure 35) are shim type cartridge type and are located in the hydrostatic pump (not on the manifold block) under plugs 1 and 2. Plug 2 is located in the same location as plug 1, except it is on the bottom side of the pump. Relief valve 1 is **reverse** and 2 is **forward**.

NOTICE

Axle Pumps supplied **after 01/01/2003 DO NOT** have adjustable relief cartridges. The pressure is fixed at $2,900 \pm 145$ psi. If the relief pressure is not within normal range, the complete cartridge must be replaced.

1. Clean the area around the cap.
2. Remove the cap.
3. Carefully remove the valve cartridge.
4. Using an **allen wrench**, remove the top nut (extreme care must be taken not to loosen existing shims, spring, or valve) Add or remove shims as required. **Adding** shims increases pressure; **removing** shims lowers pressure. One shim is equal to approximately 50 psi. Shim P/N is 34538.
5. Install the top nut and install valve in the pump cavity using extreme care not to bind.
6. Install the valve cap.
7. Re-test pressure, further adjustment may be needed if pressure is not correct.

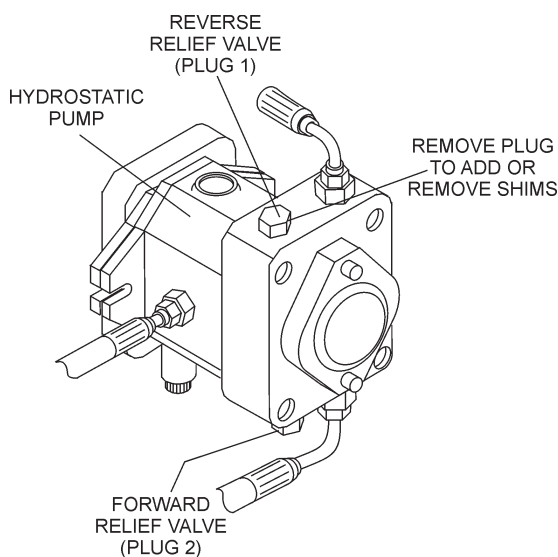

Figure 35. Adjusting Forward/Reverse Relief Valves

Steering Relief Valve Pressure Adjustment

To adjust the relief valve steering pressure perform the following:

1. Insert an 8 mm allen wrench into steering relief **port 4** (Figure 36) on the manifold block.
2. On the manifold, connect a 5,000 psi pressure gauge into quick disconnect test **port 1**.
3. Start the engine and run at full throttle.
4. Turn the steering wheel to the **left or right** (maximum) and hold. Read the steering relief pressure. The **relief pressure** reading for the **steering** test port 1 will should be 700 psi.
5. If the steering relief pressure is not 700 psi, using the allen wrench adjust the pressure at **port 4** until the pressure gauge reads 500 psi.

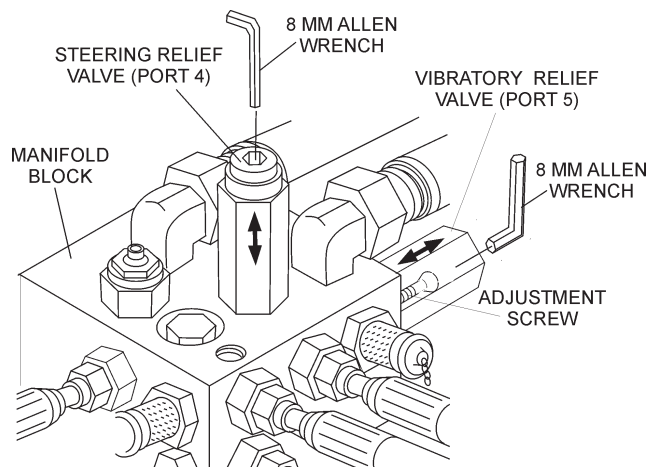

Figure 36. Steering and Vibration Relief Valves

Vibration Relief Valve Pressure Adjustment

1. Insert an 8 mm allen wrench into steering relief **port 5** (Figure 36) on the manifold block.
2. On the manifold block, insert a 5,000 psi pressure gauge into quick disconnect test **port 1**.
3. Start the engine and run at full throttle.
4. To start the vibration, **press** the pushbutton switch (vibration control) located on top of the travel lever. The relief pressure should read 800 ~ 1,000 psi.
5. If the vibration relief pressure is not 800 ~ 1,000 psi using the allen wrench adjust the pressure at **port 5** until the pressure gauge reads correctly.

Removing and Replacing Hydrostatic Pump

1. Set the parking brake.
2. Disconnect the battery.
3. Clean the pump and all connections.
4. Mark and disconnect all hoses and lines from the pump.
5. Disconnect the forward / reverse control cable.
6. Disconnect the pump support bracket.
7. Remove the engine mounting bolts.
8. Elevate the pump and engine assembly using a proper lifting device.
9. Disconnect and remove the hydrostatic pump assembly.
10. Repair or replace the hydrostatic pump as required.
11. Install the hydrostatic pump in the reverse order of removal, using *Loctite 271* on all mounting bolts and nuts.
12. Test operate. Test and adjust the forward and reverse relief pressures as required. Adjust the forward / reverse control cable.

Removing and Replacing Vibration/Steering Pump

1. Remove the hydrostatic pump as per preceding instructions.
2. Remove all hoses and lines.
3. Disconnect the vibration / steering pump and remove.
4. Repair or replace pump as required.
5. Install the pump in the reverse order of removal, using *Loctite 271* on all mounting bolts and nuts.
6. Test operate. Test and adjust the forward and reverse pressure relief valves as required. Adjust the **forward/reverse control cable**. Test and adjust the vibration and steering pressure relief valves as required.

Drums and Main Frame

The front drum is designed to apply vibration and compaction force to the operating surface for compaction. This vibration and compaction force is produced when the vibrator shaft is rotated. Maximum efficiency is achieved only when the engine is operated at full throttle.

A single drive motor is mounted on the left side of the drum and is shockmounted. This type of drive motor is designed for maximum torque and power.

The vibrator is driven by a gear motor coupled to the vibrator shaft. The vibrator assembly rotates inside of a sealed housing containing oil to lubricate the bearings. This side of the drum is also shock mounted.

Front and Rear Drum Removal and Disassembly.

The removal and disassembly of the front and rear drums shall be referenced by Figures 37, 38, and 39 on the following pages. When reassembling the front drum use *Loctite 271* on all mounting hardware.

AR-13H RIDE-ON ROLLER — MAINTENANCE

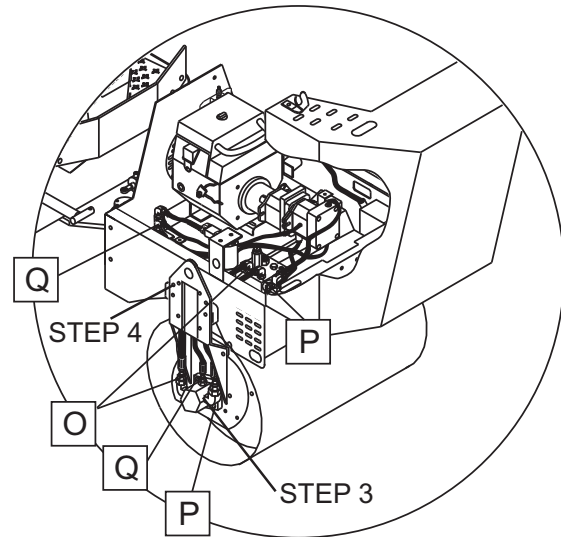
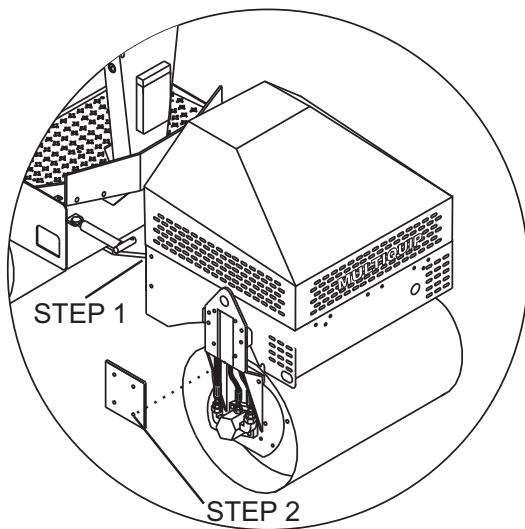

1. JACK FRAME UP SLIGHTLY AT ARTICULATION JOINT.
2. REMOVE THE FOUR ALLEN HEAD SCREWS HOLDING THE SIDE COVER OF THE DRUM SUPPORT PLATE.

3. MARK AND DISCONNECT HOSES FROM MOTOR AND MANIFOLD.
4. REMOVE FOUR ALLEN HEAD SCREWS FROM DRUM SUPPORT PLATES.(SCREWS MAY NEED TO BE HEATED TO REMOVE)

5. REMOVE NUTS SECURING FLANGE ASSEMBLY TO DRUM SUPPORT PLATE AND PULL OFF OF FLANGE ASSEMBLY.
6. REMOVE THE SIX 9/16 BOLTS SECURING EXCITER PLATE TO DRUM WALL

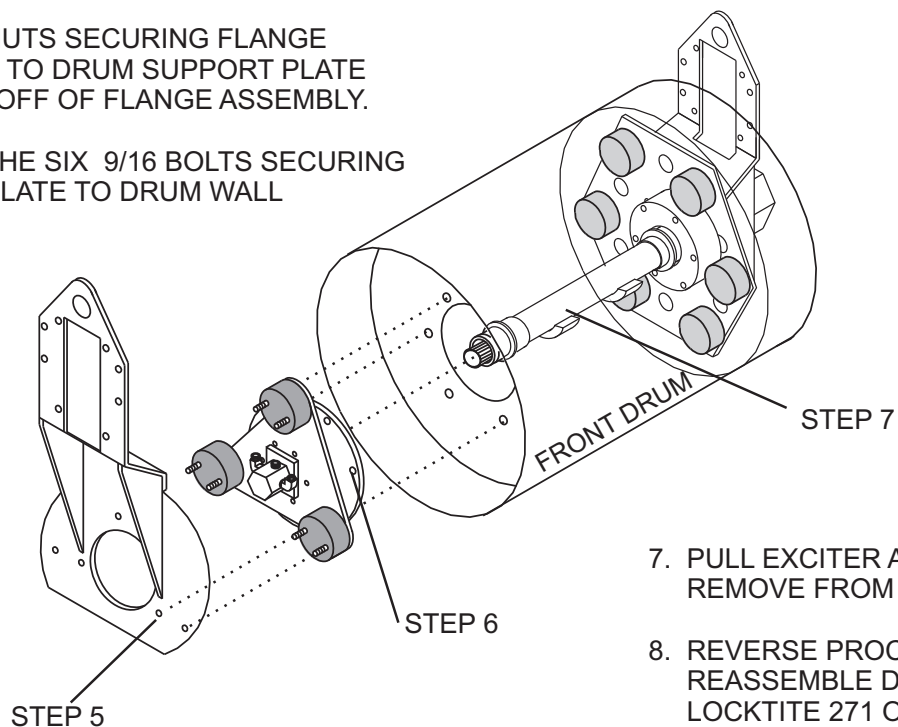

7. PULL EXCITER ASSEMBLY TO REMOVE FROM DRUM INTERIOR.
8. REVERSE PROCEDURES TO REASSEMBLE DRUM. USE LOCKTITE 271 ON ALL BOLTS AND NUTS.

Figure 37. Front-Right Drum Removal

AR-13H RIDE-ON ROLLER — MAINTENANCE

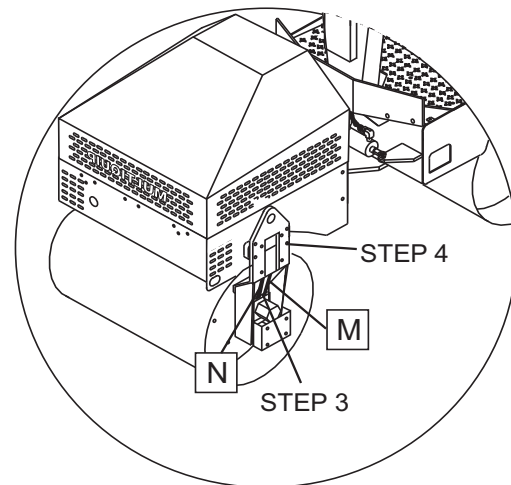
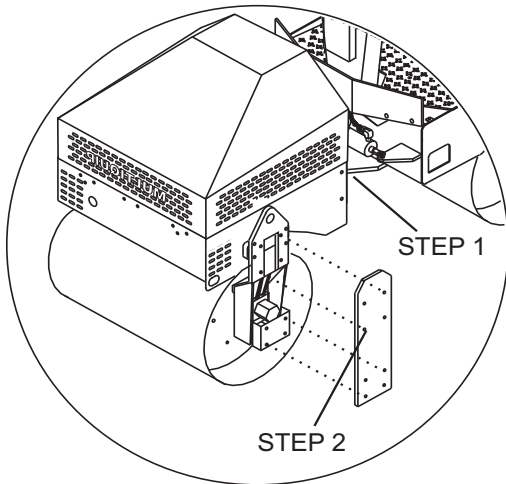

1. JACK FRAME UP SLIGHTLY AT ARTICULATION JOINT.

2. REMOVE THE EIGHT ALLEN HEAD SCREWS HOLDING THE SIDE COVER OF THE DRUM SUPPORT PLATE.

3. MARK AND DISCONNECT HOSES FROM MOTOR.

4. REMOVE FOUR ALLEN HEAD SCREWS FROM DRUM SUPPORT PLATE. (SCREWS MAY NEED TO BE HEATED TO REMOVE)

5. PULL DRUM SUPPORT PLATE OFF DRIVE PLATE ASSEMBLY.

6. REMOVE FOUR ALLEN HEAD SCREWS SECURING MOTOR TO DRUM SUPPORT PLATE AND SET ASIDE.

7. REMOVE SIX NUTS SECURING DRIVE PLATE TO SHOCK MOUNTS. PULL OFF DRIVE PLATE AND SET ASIDE.

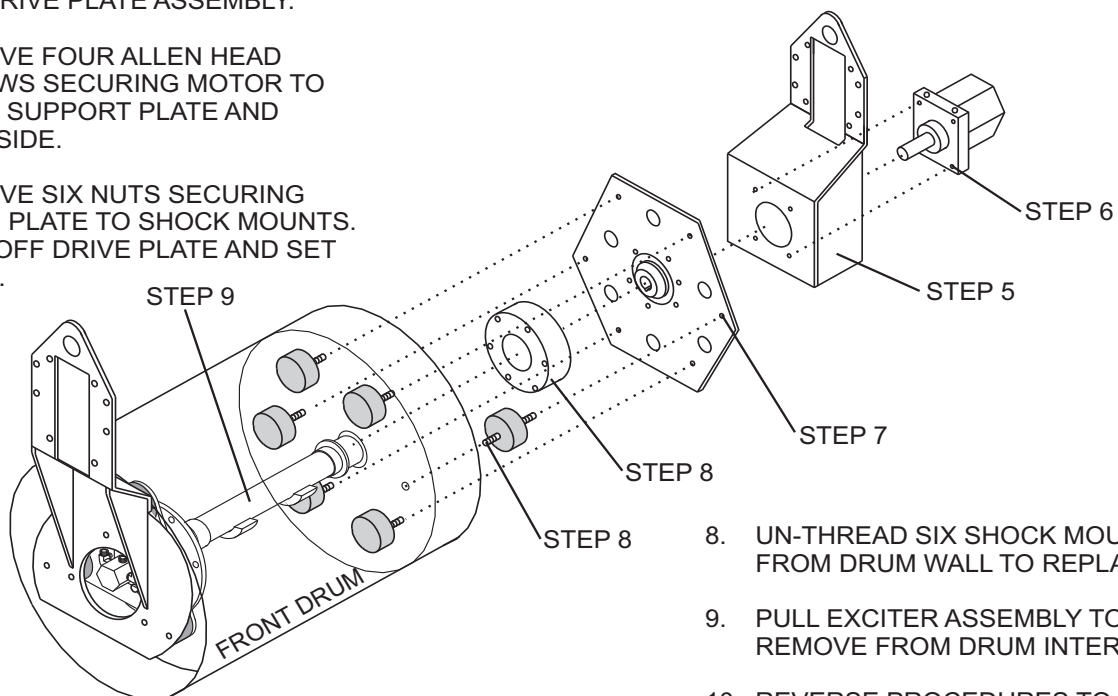

8. UN-THREAD SIX SHOCK MOUNTS FROM DRUM WALL TO REPLACE.

9. PULL EXCITER ASSEMBLY TO REMOVE FROM DRUM INTERIOR.

10. REVERSE PROCEDURES TO REASSEMBLE DRUM. USE LOCKTITE ON ALL NUTS AND BOLTS.

Figure 38. Front-Left Drum Removal

AR-13H RIDE-ON ROLLER — MAINTENANCE

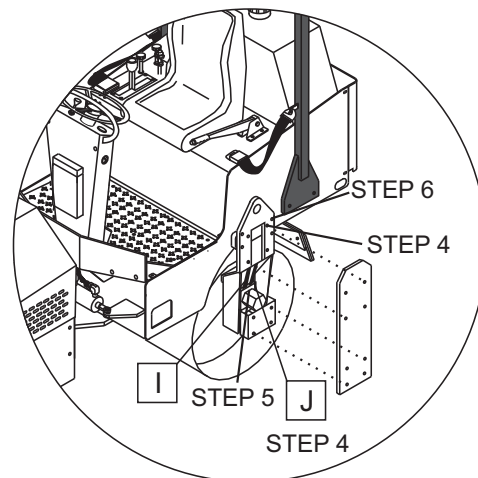
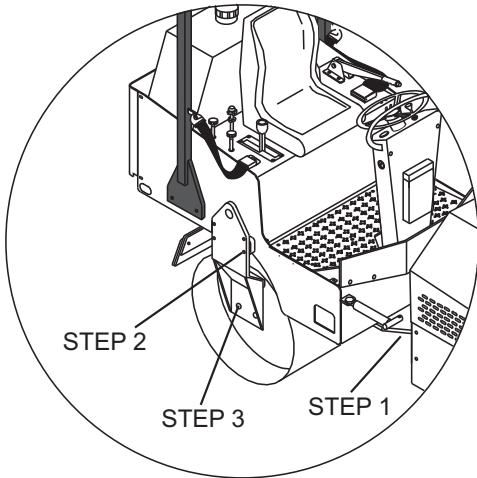

1. JACK FRAME UP SLIGHTLY AT ARTICULATION JOINT.
2. REMOVE THE FOUR ALLEN HEAD SCREWS SECURING THE DRUM SUPPORT PLATE TO THE FRAME.
3. REMOVE NUTS SECURING BEARING FLANGE TO BASE OF DRUM SUPPORT PLATE.
7. REMOVE TWO NUTS SECURING DRUM SUPPORT PLATE TO FLANGE. PULL OFF LEFT DRUM SUPPORT PLATE AND SET ASIDE.
8. PULL FLANGE OFF DRUM ROD FOR SERVICE.
9. PULL RIGHT DRUM SUPPORT PLATE OFF DRIVE PLATE ASSEMBLY.

4. REMOVE ALLEN HEAD SCREWS HOLDING THE SIDE COVER OF THE DRUM SUPPORT PLATE.
5. MARK AND DISCONNECT HOSES FROM MOTOR.
6. REMOVE FOUR ALLEN HEAD SCREWS FROM DRUM SUPPORT PLATES.

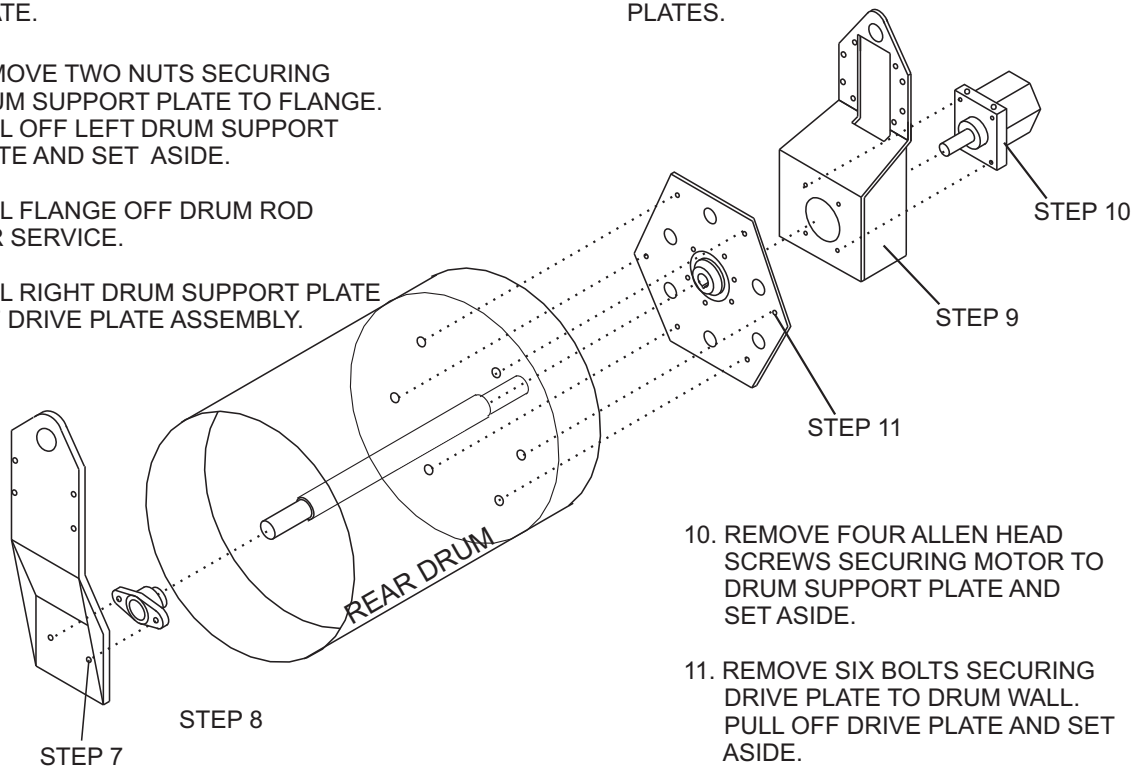

10. REMOVE FOUR ALLEN HEAD SCREWS SECURING MOTOR TO DRUM SUPPORT PLATE AND SET ASIDE.
11. REMOVE SIX BOLTS SECURING DRIVE PLATE TO DRUM WALL. PULL OFF DRIVE PLATE AND SET ASIDE.
12. REVERSE PROCEDURES TO REASSEMBLE DRUM.

Figure 39. Rear Drum Removal/Installation

AR-13H RIDE-ON ROLLER — MAINTENANCE

Alternator/Regulator

The AR-13H is equipped with a 20 amp charging system. This system uses three charge coils connected in parallel. The windings of each coil are wound with heavy-duty insulated wire and are further protected by insulating material for long life. A voltage regulator is provided to control the amount of charge voltage being delivered to the 12 volt electrical system. For servicing this charging system, contact your Honda dealer.

Neutral Safety Switch

The *travel lever* is provided with a *neutral safety switch* (Figure 40) that prevents the engine from starting when the lever is in the forward or reverse drive position. Lever must be placed in the neutral position in order for the starter to function.

To check this switch, remove the panel located below and to the rear of the floor. This switch is mounted to the lower forward/reverse lever mechanism. Disconnect the *white* and *green* wires. Place the lever in neutral and test for continuity. Place the lever in forward or reverse; no continuity should be present. Repair or replace as required.

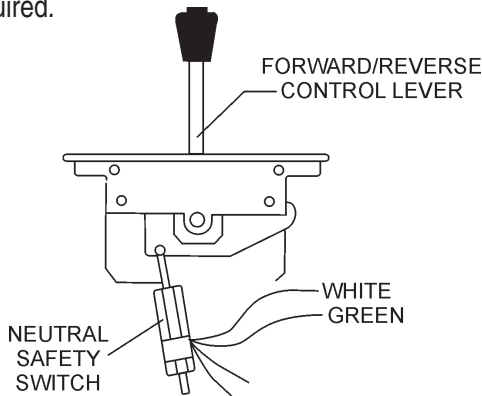

Figure 40. Safety Switch

Vibrator Solenoid

The vibrator solenoid (Figure 41) is located in the manifold valve block and is controlled by the vibration switch located on top of the travel lever. This solenoid controls the vibration control valve which supplies hydraulic oil to the vibration drive motor.

To test the vibration solenoid, turn the ignition switch on. Check for proper supply voltage and ground. If proper voltage and ground are present, check the solenoid for continuity. If no continuity, replace the solenoid coil. If continuity is present, place your hand on the solenoid and turn the switch to the **ON** position; movement should be felt. **DO NOT START THE ENGINE FOR THIS TEST**

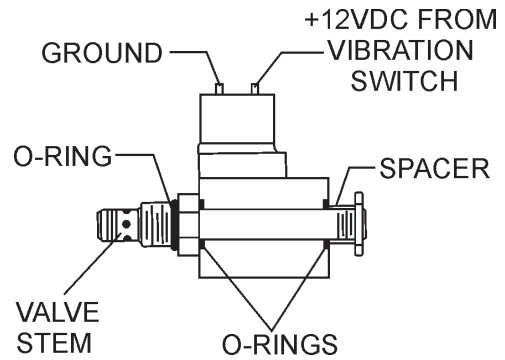

Figure 41. Vibration Solenoid

Battery

Mishandling of the battery shortens the service life of the battery and adds to maintenance cost. When handling the battery do the following:

- Be careful not to let the battery electrolyte come in contact with your body or clothing.
- Always wear eye protection and rubber gloves, since the battery contains sulfuric acid which burns skin and eats through clothing.

! CAUTION - BATTERY ACID BURN HAZARD

If your clothing or skin comes in contact with the battery acid, **immediately** wash off with running water and get medical attention.

- Check the battery regularly and make sure that each electrolyte level is to the bottom of the vent well (Figure 42). If necessary add only distilled water in a well-ventilated area.

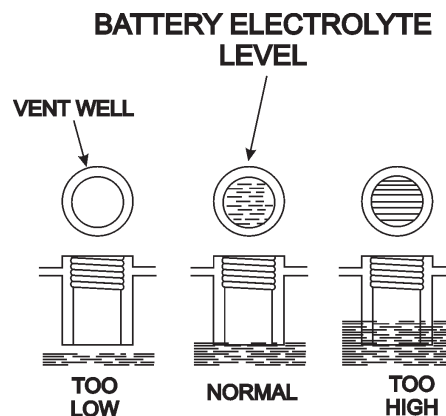

Figure 42. Battery Fluid Levels

AR-13H RIDE-ON ROLLER — PREPARATION FOR LONG-TERM STORAGE

Roller Storage

For storage of the roller for over 30 days, the following is recommended:

- Drain the fuel tank completely, or add STA-BIL to the fuel.
- Run the engine until the fuel in the injection system is completely consumed.
- Completely drain used oil from the engine crankcase and fill with fresh clean oil, then follow the procedures described in the engine manual for engine storage.
- Drain water tank
- Clean the entire roller and engine compartment.
- Remove battery and store it in cool dry place.
- Cover the roller and place it a clean dry area, that is protected from harsh elements.
- Remove ignition key, and store in a safe place.

AR-13H RIDE-ON ROLLER — MANIFOLD TEST PORTS

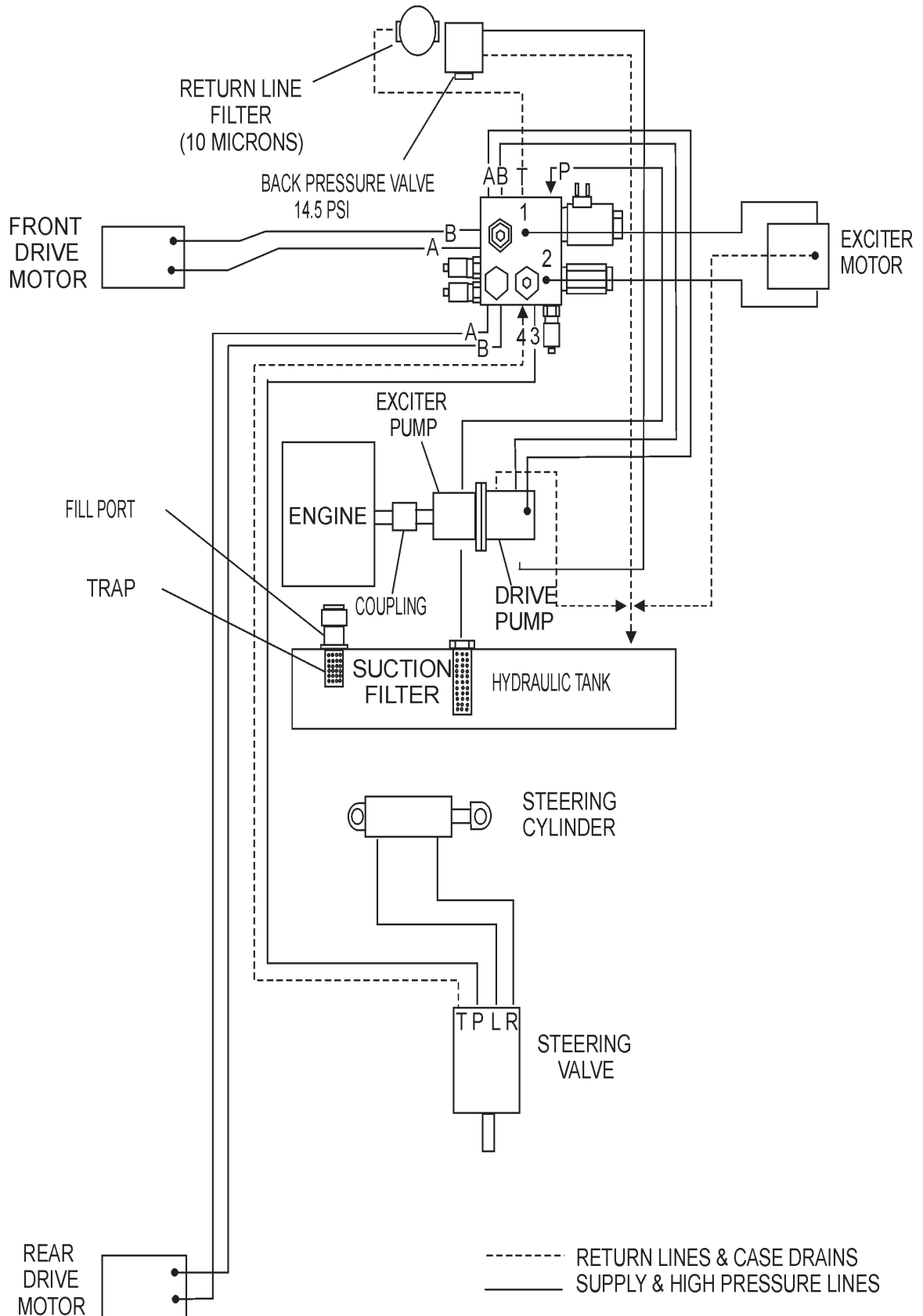

Figure 29. Manifold Test Ports

AR-13H RIDE-ON ROLLER — HYDRAULIC SYSTEM DIAGRAM

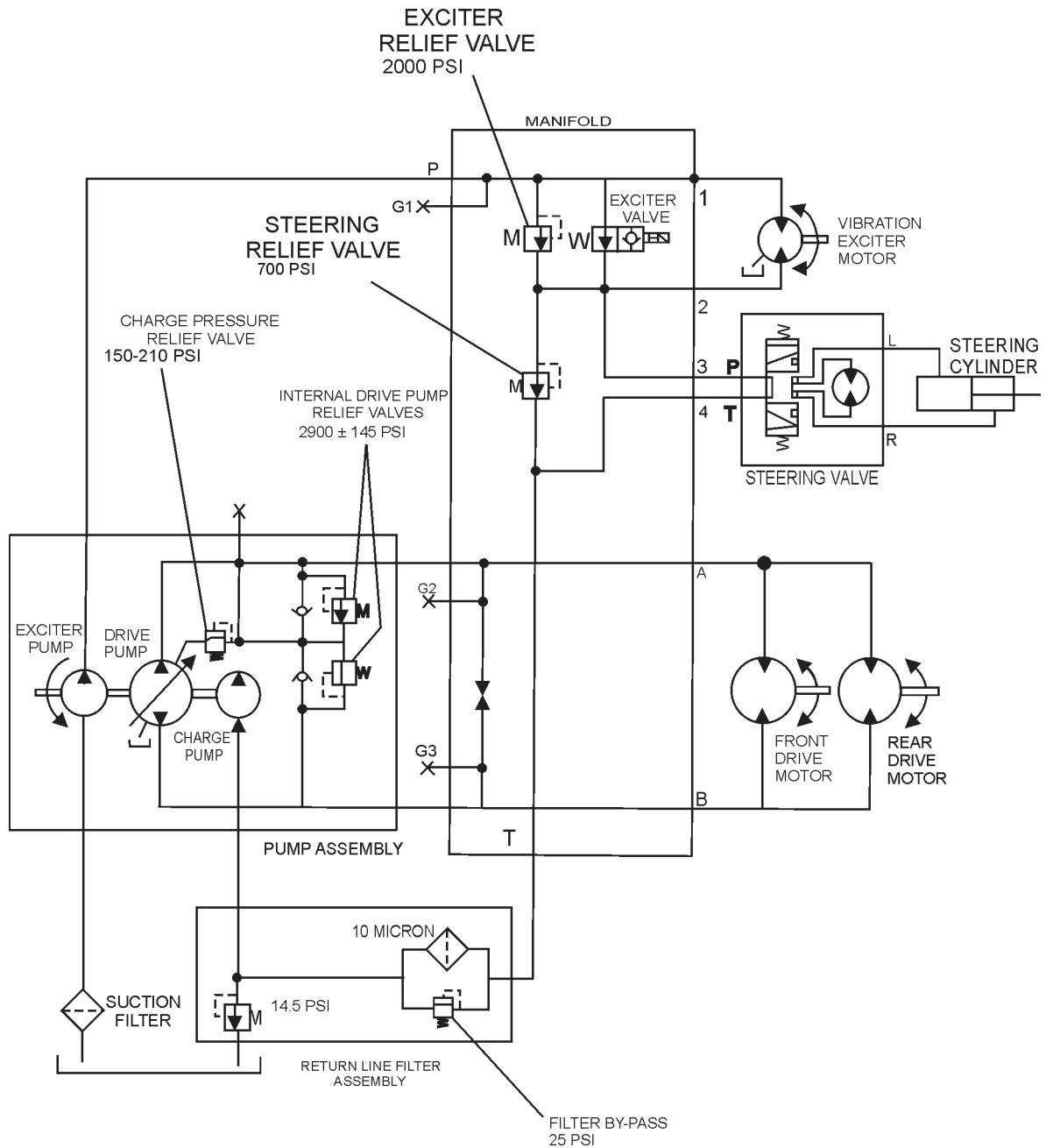

Figure 30. Hydraulic System Diagram

AR-13H ROLLER — ELECTRIC WIRING DIAGRAM (S/N 241001 AND BELOW)

S/N 241001 AND BELOW

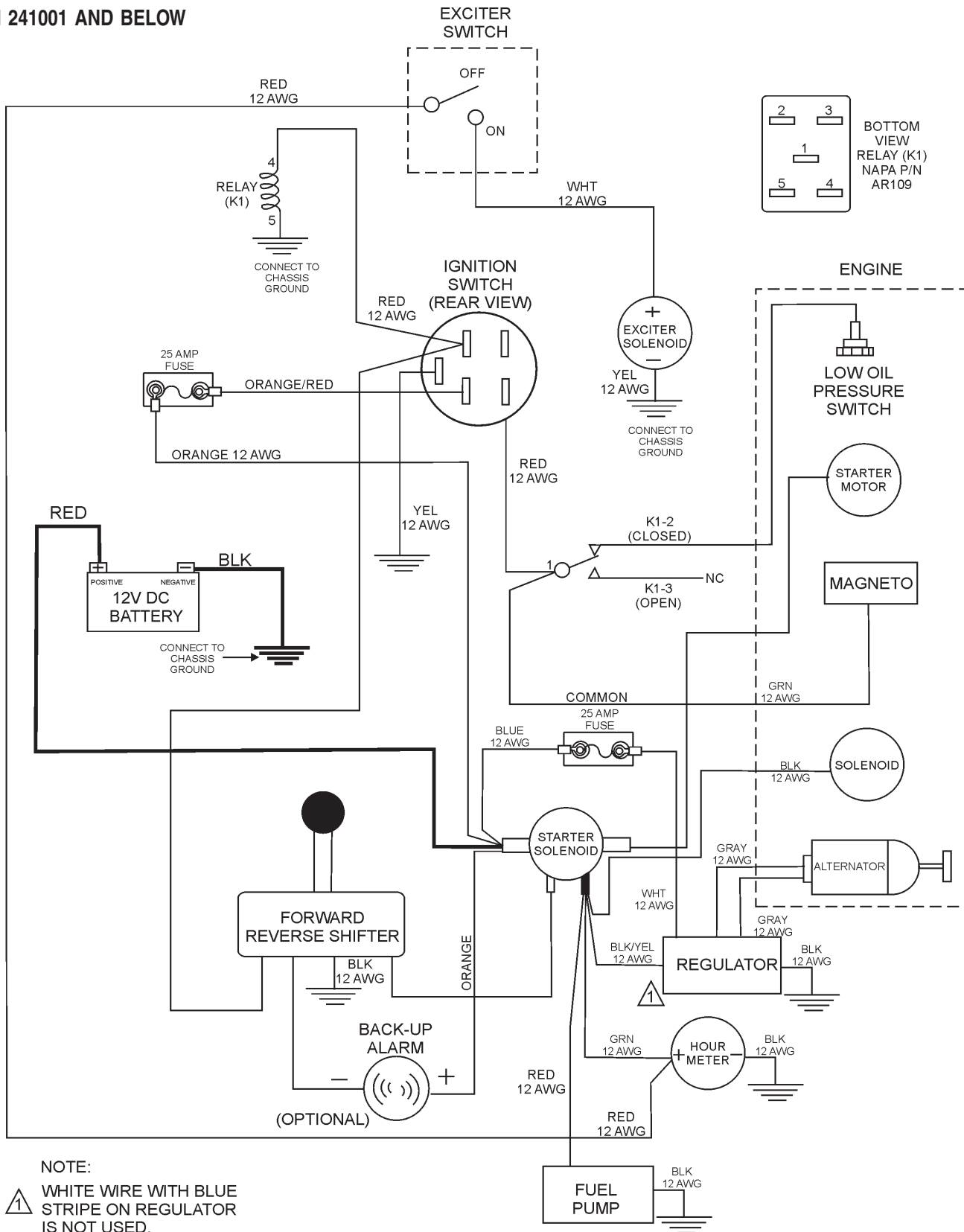
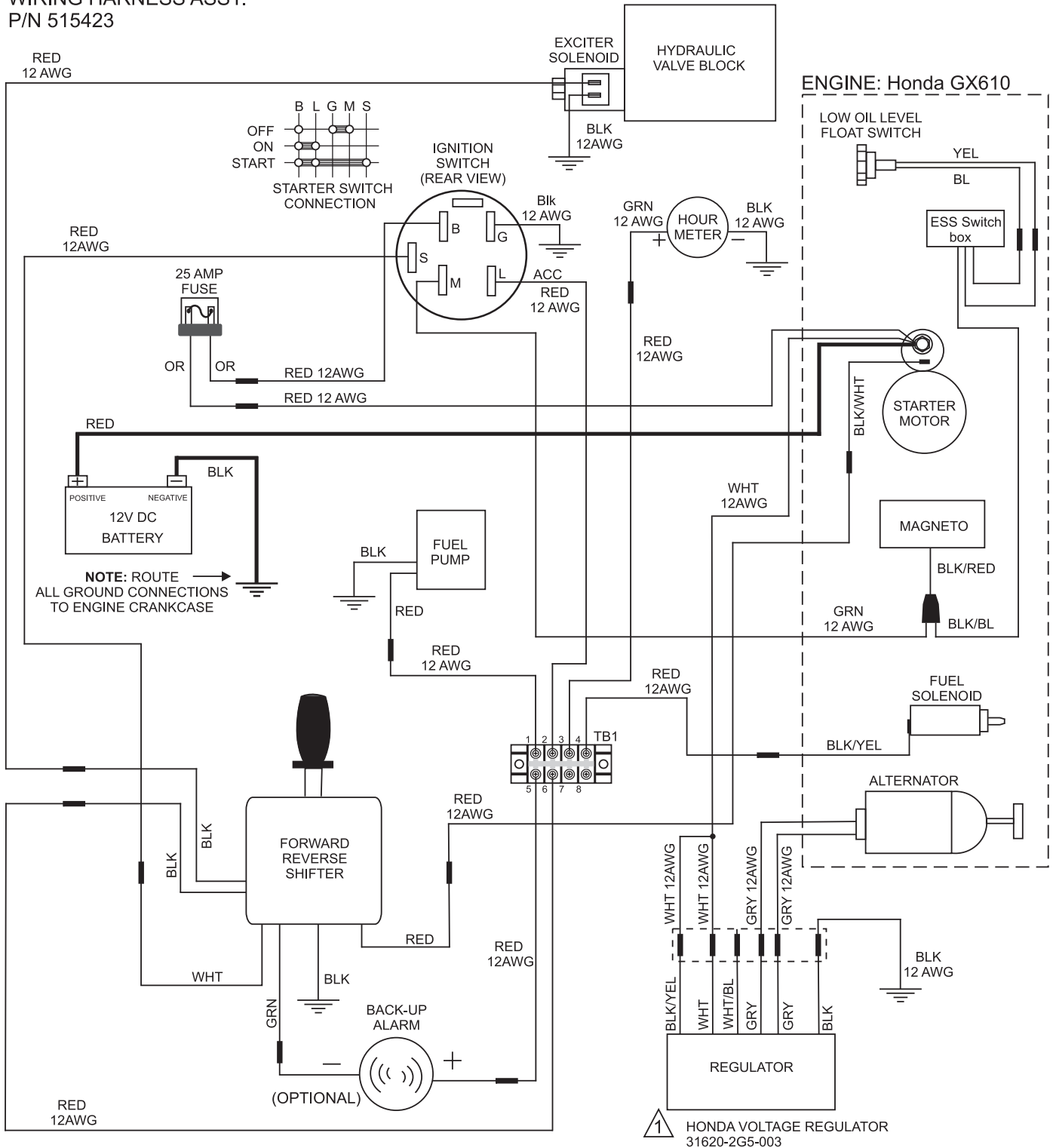

Figure 31. Electrical Diagram

AR-13H ROLLER — ELECTRIC WIRING DIAGRAM (S/N 241002 AND ABOVE)

S/N 241002 AND ABOVE

WIRING HARNESS ASSY.
P/N 515423



NOTE:

⚠ WHITE WIRE WITH BLUE STRIPE ON REGULATOR IS NOT USED.

BL = BLUE
GRY = GRAY
GRN = GREEN
OR = ORANGE

BLK = BLACK
YEL = YELLOW
WHT = WHITE

⚠ HONDA VOLTAGE REGULATOR
31620-2G5-003

AR-13H RIDE-ON ROLLER — HYDRAULIC HOSE CONNECTIONS

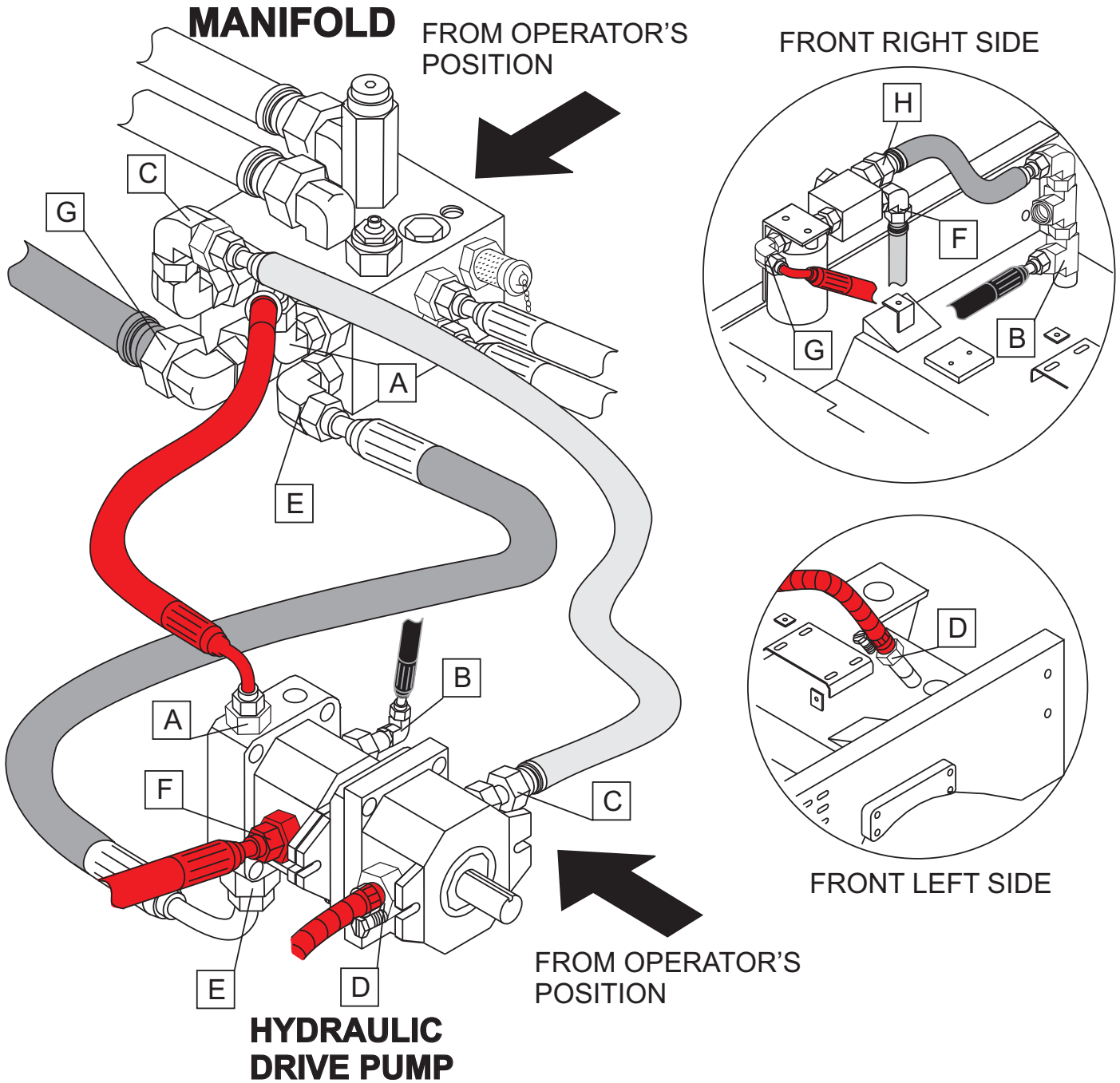

NOTES

HOSES SHADED FOR VISUAL CLARITY.

Figure 32. Hydraulic Hose Connections 1

AR-13H RIDE-ON ROLLER — HYDRAULIC HOSE CONNECTIONS

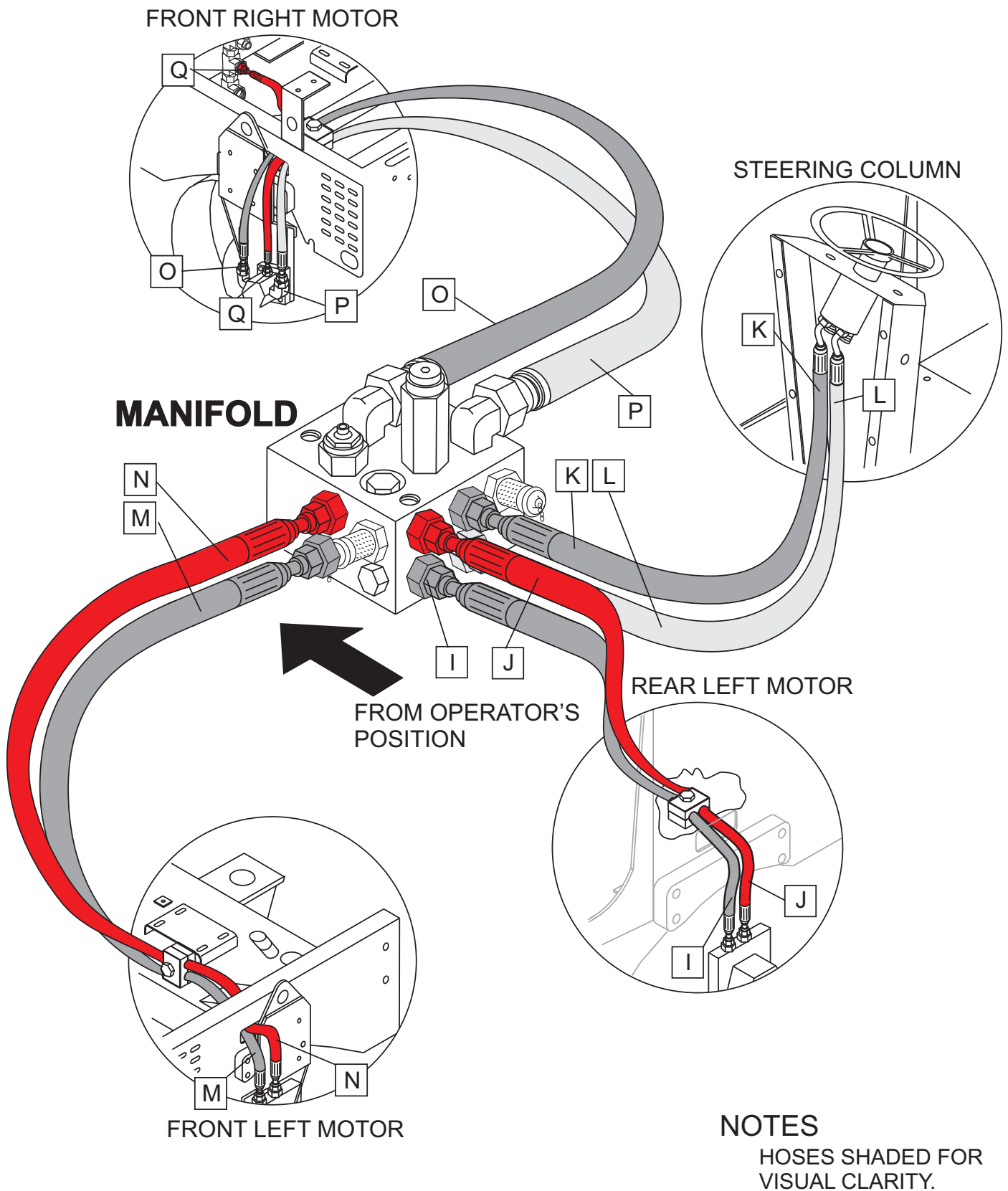

Figure 33. Hydraulic Hose Connections 2

AR-13H RIDE-ON ROLLER — TROUBLESHOOTING (ROLLER)

TABLE 6. ROLLER TROUBLESHOOTING

SYMPTOM	POSSIBLE PROBLEM	SOLUTION
Low Vibration	Low engine RPM?	Check and adjust engine speed.
	Low hydraulic pressure?	Check and adjust hydraulic pressure.
No Vibration	No voltage to 12 volt solenoid?	Check vibration switch, check coil for continuity.
	No oil pressure?	Check for proper oil pressure or defective relief valve.
	Broken motor coupler?	Replace coupler.
Slow Steering	Low hydraulic pressure?	Check pressure.
	Steering column connector?	Inspect bearings and grease if necessary.
	Defective steering cylinder?	Check seals, replace if necessary.
Steers Slow in One Direction	Defective Steering cylinder?	Inspect cylinder for contamination, replace if necessary.
Slow Forward/Reverse Speed	Low hydraulic pressure?	Check pressure.
	Rubber scrapper adjustment incorrect?	Check for proper adjustment against drum.
	Rubber shock mount loose?	Inspect for broken mount, replace if necessary.
	Free wheel valve " <i>open</i> "?	Close valve.
	Speed control cable out of adjustment?	Inspect cable and adjust if necessary.
Main Hydraulic Pressure Low	Incorrect engine speed?	Adjust engine speed to correct speed.
	Broken rubber shock mounts or drive plate?	Inspect for cracks, replace if necessary.
	Drive motor hardware not secure?	Check motor nut and key coupler.

AR-13H RIDE-ON ROLLER — TROUBLESHOOTING (ENGINE)

TABLE 7. ENGINE TROUBLESHOOTING

SYMPTON	POSSIBLE PROBLEM	SOLUTION
Engine will not start or start is delayed, although engine can be turned over.	No Fuel reaching injection pump?	Add fuel. Check entire fuel system.
	Defective fuel pump?	Replace fuel pump.
	Fuel filter clogged?	Replace fuel filter and clean tank.
	Faulty fuel supply line?	Replace or repair fuel line.
	Compression too low?	Check piston, cylinder and valves. Adjust or repair per engine repair manual.
	Fuel pump not working correctly?	Repair or replace fuel pump.
	Oil pressure too low?	Check engine oil pressure.
	Low starting temperature limit exceeded	Comply with cold starting instructions and proper oil viscosity.
	Defective battery?	Charge or replace battery.
At low temperatures engine will not start.	Engine oil too thick?	Refill engine crankcase with correct type of oil for winter environment.
	Defective battery?	Replace battery.
Engine fires but stops soon as starter is switched off.	Fuel filter blocked?	Replace fuel filter.
	Fuel supply blocked?	Check the entire fuel system.
	Defective fuel pump?	Replace fuel pump.
Engine stops by itself during normal operation.	Fuel tank empty?	Add fuel.
	Fuel filter blocked?	Replace fuel filter.
	Defective fuel pump?	Replace fuel pump.
	Mechanical oil pressure shutdown sensor stops the engine due to low oil?	Add oil. Replace low oil shutdown sensor if necessary.

AR-13H RIDE-ON ROLLER — TROUBLESHOOTING (ENGINE)

TABLE 7. ENGINE TROUBLESHOOTING (CONTINUED)

SYMPTON	POSSIBLE PROBLEM	SOLUTION
Low engine power, output and speed.	Fuel tank empty?	Replace fuel filter.
	Fuel filter clogged?	Replace fuel filter.
	Fuel tank venting is inadequate?	Ensure that tank is adequately vented.
	Leaks at pipe unions?	Check threaded pipe unions tape and tighten unions as required.
	Speed control lever does not remain in selected position?	See engine manual for corrective action.
	Engine oil level too full?	Correct engine oil level?
Low engine power output and low speed, black exhaust smoke.	Air filter blocked?	Clean or replace air filter.
	Incorrect valve clearances?	Adjust valves per engine specification.
	Malfunction at injector?	See engine manual.
Air-cooled diesel engine runs very "HOT". Cylinder head overheats.	Too much oil in engine crankcase?	Drain off engine oil down to uppermark on dipstick.
	Entire cooling air system contaminated blocked?	Clean cooling air system, and cooling fin areas.

OPERATION MANUAL

HERE'S HOW TO GET HELP

PLEASE HAVE THE MODEL AND SERIAL
NUMBER ON-HAND WHEN CALLING

UNITED STATES

Multiquip Inc.

(310) 537- 3700
6141 Katella Avenue Suite 200
Cypress, CA 90630
E-MAIL: mq@multiquip.com
WEBSITE: www.multiquip.com

CANADA

Multiquip

(450) 625-2244
4110 Industriel Boul.
Laval, Quebec, Canada H7L 6V3
E-MAIL: infocanada@multiquip.com

UNITED KINGDOM

Multiquip (UK) Limited Head Office

0161 339 2223
Unit 2, Northpoint Industrial Estate,
Globe Lane,
Dukinfield, Cheshire SK16 4UJ
E-MAIL: sales@multiquip.co.uk

© COPYRIGHT 2021, MULTIQUIP INC.

Multiquip Inc, the MQ logo and the Mayco logo are registered trademarks of Multiquip Inc. and may not be used, reproduced, or altered without written permission. All other trademarks are the property of their respective owners and used with permission.

This manual MUST accompany the equipment at all times. This manual is considered a permanent part of the equipment and should remain with the unit if resold.

The information and specifications included in this publication were in effect at the time of approval for printing. Illustrations, descriptions, references and technical data contained in this manual are for guidance only and may not be considered as binding. Multiquip Inc. reserves the right to discontinue or change specifications, design or the information published in this publication at any time without notice and without incurring any obligations.

