

Hydraulic diagram AV16K

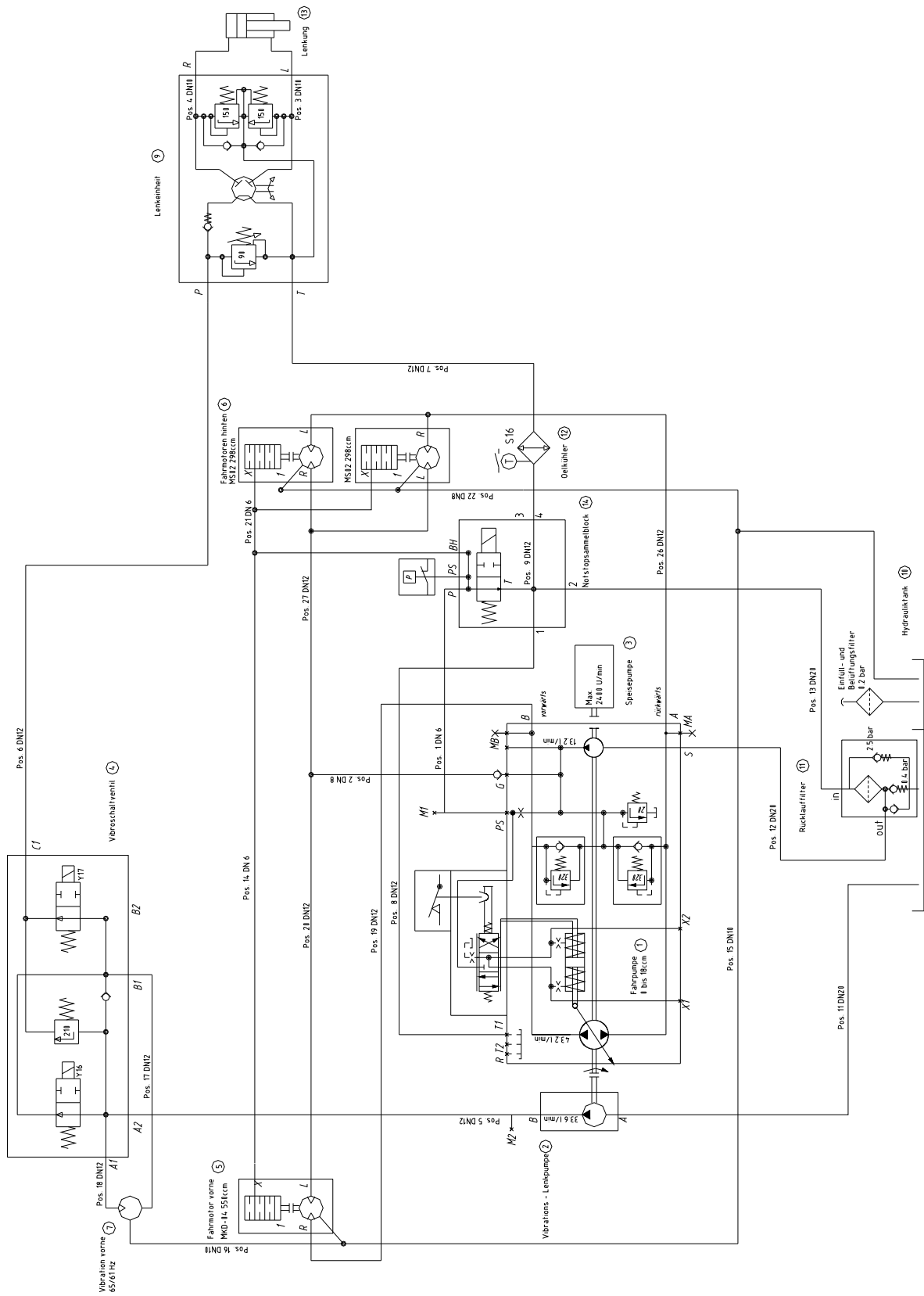

AV16K hydraulics diagram legend

Element	Description
1	Drive pump
2	Vibration steering pump
3	Feed pump
4	Vibro switch valve
5	Front drive motor
6	Rear drive motor
7	Vibration front
9	Steering unit
10	Hydraulic tank
11	Return filter
12	Oil cooler
13	Steering
14	Emergency stop collector block
