

OPERATION MANUAL



MAYCO SERIES MODEL C30HDN CONCRETE PUMP (NISSAN ENGINE)

Revision #12 (09/18/24)

To find the latest revision of this publication or associated parts manual, visit our website at:

www.multiquip.com



THIS MANUAL MUST ACCOMPANY THE EQUIPMENT AT ALL TIMES.



CALIFORNIA — Proposition 65 Warning

Engine exhaust and some of its constituents are known to the State of California to cause cancer, birth defects and other reproductive harm.

WARNING



SILICOSIS WARNING

Grinding/cutting/drilling of masonry, concrete, metal and other materials with silica in their composition may give off dust or mists containing crystalline silica. Silica is a basic component of sand, quartz, brick clay, granite and numerous other minerals and rocks. Repeated and/or substantial inhalation of airborne crystalline silica can cause serious or fatal respiratory diseases, including silicosis. In addition, California and some other authorities have listed respirable crystalline silica as a substance known to cause cancer. When cutting such materials, always follow the respiratory precautions mentioned above.

WARNING



RESPIRATORY HAZARDS

Grinding/cutting/drilling of masonry, concrete, metal and other materials can generate dust, mists and fumes containing chemicals known to cause serious or fatal injury or illness, such as respiratory disease, cancer, birth defects or other reproductive harm. If you are unfamiliar with the risks associated with the particular process and/or material being cut or the composition of the tool being used, review the material safety data sheet and/or consult your employer, the material manufacturer/supplier, governmental agencies such as OSHA and NIOSH and other sources on hazardous materials. California and some other authorities, for instance, have published lists of substances known to cause cancer, reproductive toxicity, or other harmful effects.

Control dust, mist and fumes at the source where possible. In this regard use good work practices and follow the recommendations of the manufacturers or suppliers, OSHA/NIOSH, and occupational and trade associations. Water should be used for dust suppression when wet cutting is feasible. When the hazards from inhalation of dust, mists and fumes cannot be eliminated, the operator and any bystanders should always wear a respirator approved by NIOSH/MSHA for the materials being used.

**MAYCO C-30HDN (NISSAN)
CONCRETE PUMP**

Proposition 65 Warning 2
Silicosis/Respiratory Warnings 3
Pump Specifications 6
Engine Specifications 6
Pump Dimensions 7
Safety Message Alert Symbols 8-9
Rules For Safe Operation 10-12
Operation And Safety Decals 14
Important Hand Signals 15
Pump Components 16-17
Control Box Components 18
Engine Components 19
General Information 20
How It Works 21-22
Inspection 24-26
Initial Start-Up 27-28
Operating Information 29-32
Towing Guidelines 33-34
Trailer Safety Guidelines 35-37
Maintenance (Pump) 38-47
Engine RPM Adjustment 48-49
Engine Troubleshooting 50-51
Wiring Diagram 52
Wiring Diagram (Trailer Lights) 53
Appendix —
 Concrete Mix Information 54-56
 Recommended Shotcrete System 57-58
 Recommended Shotcrete Accessories 59-60
 Slump Test Procedure 61

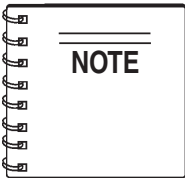

Specifications are subject to change without notice.

C-30HDN PUMP — PUMP SPECIFICATIONS

TABLE 1. C-30HDN PUMP SPECIFICATIONS

Pump Type	Reciprocating Piston
Pumping Rate	Up to 25 cu. yds. per hour*
Vertical Pumping Height	Up to 150 ft. (45.73 m)
Horizontal Pumping Distance	400 - 500 ft. (122 - 152 m)*
Maximum Aggregate Size	1/2 in. minus (12.7 mm)
Hopper Capacity	6 cu. ft. etc.
Material Hose	2" or 2-1/2" (50.8 or 63.5 mm)
Weight	2,950 lbs. (1,338 Kg)
Lube oil Box	7 Gallons (26.5 Liters)
Remote Control	125 ft. cable Standard
Tire Size	7.35" x 14" (187 x 356 mm)
* Volume output will vary depending on mix design, slump, line size used and job site conditions.	

TABLE 2. ENGINE SPECIFICATIONS

	Model	NISSAN A15 INDUSTRIAL ENGINE
Engine	Type	4 stroke, overhead valve, single cylinder horizontal shaft gasoline engine
	Bore X Stroke	2.99 x 3.23 in. (76 x 82 mm)
	Compression Ratio	9.0:1
	Displacement	90.784 cu. (1,487 cc)
	Continuous Output	39 H.P./3600 R.P.M.
	Fuel Tank Capacity	Approx. 14 U.S. Gallons (53 liters)
	Fuel Type	Unleaded Gasoline
	Lube Oil Capacity	3.2 liters (3-3/8 qt)
	Engine Speed Full Load	2650 rpm ±100 (No Load 2750 rpm +/- 50) (Load 2750 rpm +/- 100)
	Engine Speed Full Idle	875 rpm ±100
	Air Cleaner	Air Horn Type
	Engine Lubrication	SAE 10W-30 (Oil Grade) SG or SF (Service Class)
	Starting Method	Electric Start
	Spark Plug	B4ES
Spark Plug Gap	0.8 - 0.9 in. (0.031-0.035 mm)	
Dimension (L x W x H)	20.78 x 20.90 x 22.69 in. (527.8 x 530.8 x 576.3 mm)	
Dry Net Weight	227 lbs (103 Kg.)	

C-30HDN PUMP — PUMP DIMENSIONS

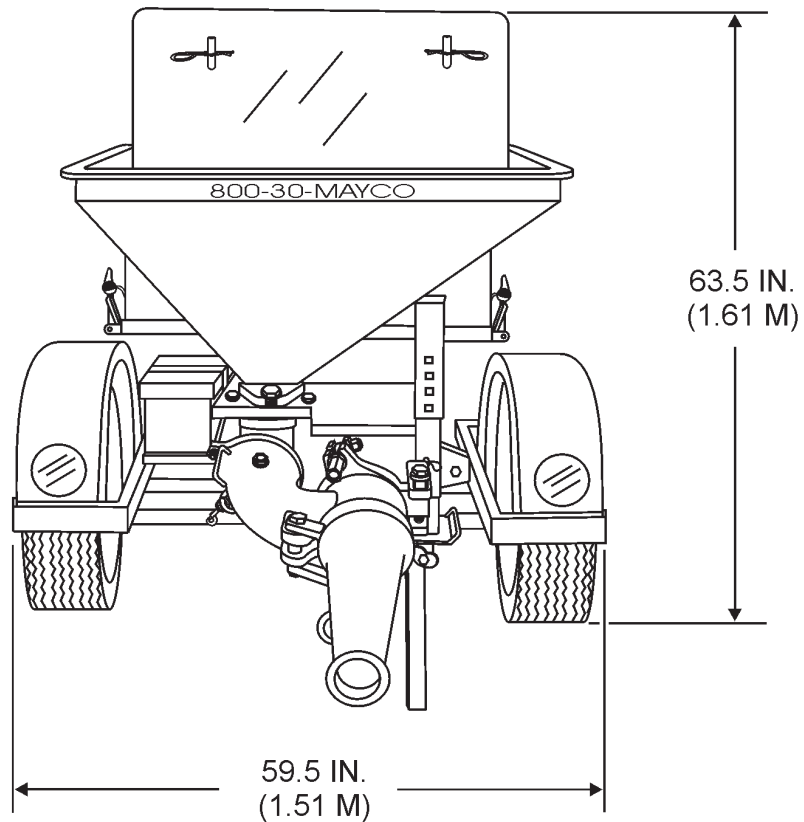
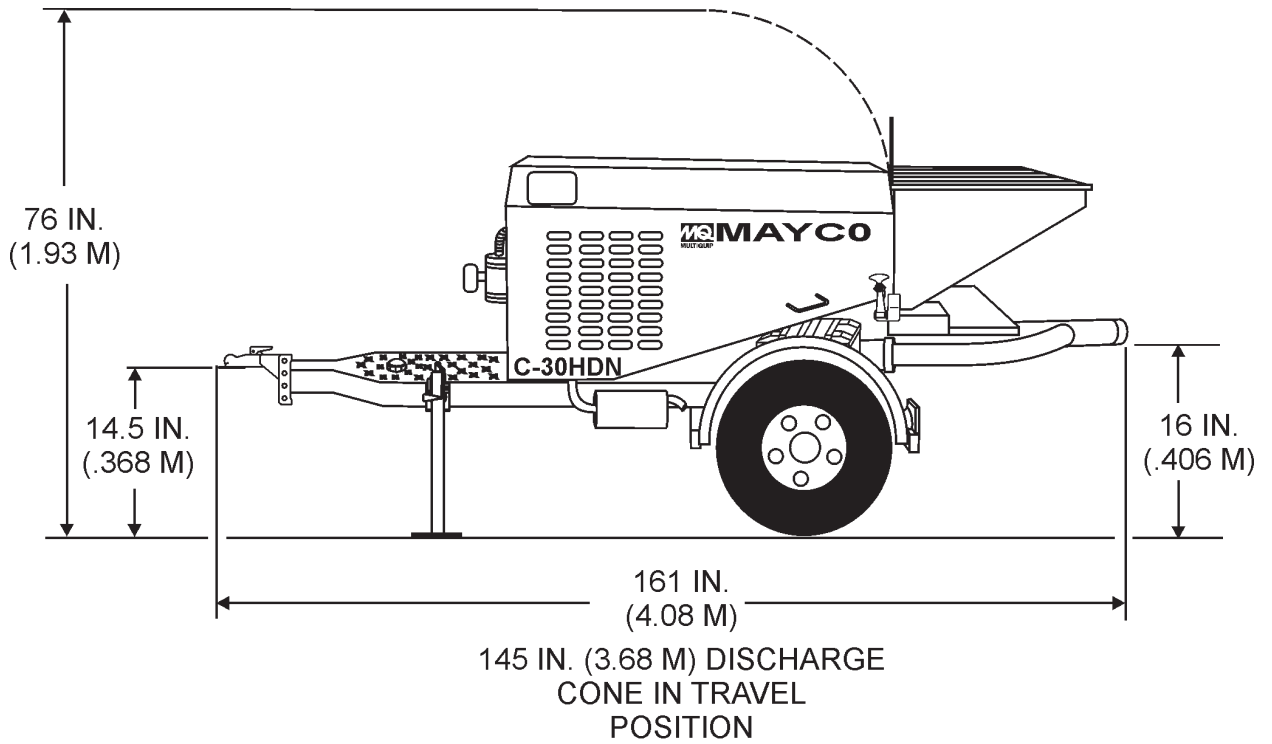
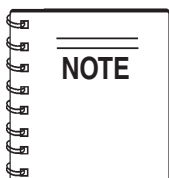

Figure 1. C-30HDN Concrete Pump Dimensions

C-30HDN PUMP — SAFETY MESSAGE ALERT SYMBOLS

FOR YOUR SAFETY AND THE SAFETY OF OTHERS!

Safety precautions should be followed at all times when operating this equipment. Failure to read and understand the Safety Messages and Operating Instructions could result in injury to yourself and others.



This Owner's Manual has been developed to provide complete instructions for the safe and efficient operation of the **Multiquip Mayco C-30HDN Concrete Pump**.

Refer to the engine manufacturers instructions for data relative to its safe operation.

Before using this pump, ensure that the operating individual has read and understands all instructions in this manual.

SAFETY MESSAGE ALERT SYMBOLS

The three (3) Safety Messages shown below will inform you about potential hazards that could injure you or others. The Safety Messages specifically address the level of exposure to the operator, and are preceded by one of three words: **DANGER**, **WARNING**, or **CAUTION**.

DANGER

You **WILL** be **KILLED** or **SERIOUSLY** injured if you do not follow directions.

WARNING

You **COULD** be **KILLED** or **SERIOUSLY** injured if you do not follow directions.

CAUTION

You **CAN** be injured if you do not follow directions

HAZARD SYMBOLS

Potential hazards associated with operation of the pump will be referenced with Hazard Symbols which appear throughout this manual, and will be referenced in conjunction with Safety Message Alert Symbols. Some examples are listed below:

WARNING - Lethal Exhaust Gases



Diesel engine exhaust gases contain poisonous carbon monoxide. This gas is colorless and odorless, and can cause death if inhaled. **NEVER** operate this equipment in a confined area or enclosed structure that does not provide ample free flow air.

WARNING - Explosive Fuel



Diesel fuel is extremely flammable, and its vapors can cause an explosion if ignited. **DO NOT** start the engine near spilled fuel or combustible fluids. **DO NOT** fill the fuel tank while the engine is running or hot.

DO NOT overfill tank, since spilled fuel could ignite if it comes into contact with hot engine parts or sparks from the ignition system. Store fuel in approved containers, in well-ventilated areas and away from sparks and flames. **NEVER** use fuel as a cleaning agent.

WARNING - Burn Hazards



Engine components can generate extreme heat. To prevent burns, **DO NOT** touch these areas while the engine is running or immediately after operations. **NEVER** operate the engine with heat shields or heat guards removed.

C-30HDN PUMP — SAFETY MESSAGE ALERT SYMBOLS

WARNING - Rotating Parts



NEVER operate equipment with covers, or guards removed. Keep **fingers, hands, hair** and clothing away from all moving parts to prevent injury.

CAUTION - Respiratory Hazards



ALWAYS wear approved **respiratory** protection.

CAUTION - Accidental Starting



ALWAYS place the **Engine ON/OFF** switch in the **OFF** position. **NEVER** perform maintenance on the unit with the ignition key in the **ON** position.

CAUTION - Sight And Hearing Hazards

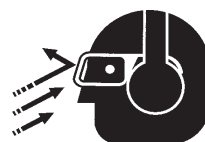

ALWAYS wear approved **eye** and **hearing** protection.

CAUTION - Over-speed Conditions



NEVER tamper with the factory settings of the engine governor or settings. Personal injury and damage to the engine or equipment can result if operating in speed ranges above maximum allowable.

CAUTION - Equipment Damage Messages

Other important messages are provided throughout this manual to help prevent damage to your concrete pump, other property, or the surrounding environment.

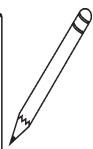
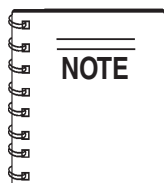

This **pump**, other property, or the surrounding environment could be damaged if you do not follow instructions.

C-30HDN PUMP — RULES FOR SAFE OPERATION

DANGER - Read Operation And Parts

Failure to follow instructions in this manual may lead to serious injury or even **death!** This equipment is to be operated by trained and qualified personnel only! This equipment is for industrial use only.

The following safety guidelines should always be used when operating the C-30HDN structural concrete pump:

GENERAL SAFETY

■ **DO NOT** operate or service this equipment before reading this entire manual.



■ This equipment should not be operated by persons under 18 years of age.

■ **NEVER** operate this equipment without proper protective clothing, shatterproof glasses, steel-toed boots and other protective devices required by the job.



■ **NEVER** operate this equipment when not feeling well due to fatigue, illness or taking medicine.

■ **NEVER** operate this equipment under the influence of drugs or alcohol.



■ **ALWAYS** check the machine for loosened threads or bolts before starting.

■ **ALWAYS** wear proper **respiratory** (mask), **hearing** and **eye** protection equipment when operating the pump.

■ Whenever necessary, replace nameplate, operation and safety decals when they become difficult read.

■ Manufacture does not assume responsibility for any accident due to equipment modifications.

■ **NEVER** use accessories or attachments, which are not recommended by Multiquip for this equipment. Damage to the equipment and/or injury to user may result.

■ **NEVER** touch the hot exhaust manifold, muffler or cylinder. Allow these parts to cool before servicing engine or pump.

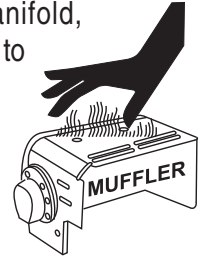

■ **High Temperatures** – Allow the engine to cool before adding fuel or performing service and maintenance functions. Contact with **hot!** components can cause serious burns.

■ The engine section of this pump requires an adequate free flow of cooling air. **NEVER** operate the pump in any enclosed or narrow area where free flow of the air is restricted. If the air flow is restricted it will cause serious damage to the pump or engine and may cause injury to people. Remember the pump's engine gives off **DEADLY** carbon monoxide gas.

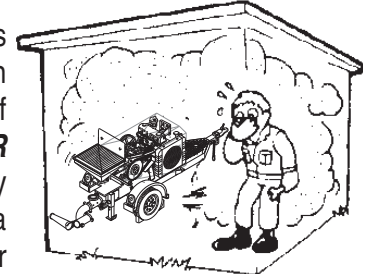

■ **ALWAYS** refuel in a well-ventilated area, away from sparks and open flames.

■ **ALWAYS** use extreme caution when working with **flammable** liquids. When refueling, **stop the engine** and allow it to cool.

■ **NEVER smoke** around or near the machine. Fire or explosion could result from **fuel vapors**, or if fuel is spilled on a **hot!** engine.



■ **NEVER** operate the pump in an explosive atmosphere or near combustible materials. An explosion or fire could result causing severe **bodily harm or even death.**

■ Topping-off filler port is dangerous, as it tends to spill fuel.

■ **ALWAYS** remove the **ignition key** when leaving the pump unattended.

■ **ALWAYS** block the **wheels** on the unit when using on a slope.

■ **ALWAYS** maintain this equipment in a safe operating condition at all times.

■ **ALWAYS** stop the engine before servicing, adding fuel or oil.

■ **NEVER** run engine without air filter. Severe engine damage may occur.

■ **ALWAYS** be sure the operator is familiar with proper safety precautions and operation techniques before using pump.

C-30HDN PUMP — RULES FOR SAFE OPERATION

- **ALWAYS** store equipment properly when it is not being used. Equipment should be stored in a clean, dry location out of the reach of children.
- **DO NOT** operate this equipment unless all guards and safety devices are attached and in place.
- **CAUTION** must be exercised while servicing this equipment. Rotating and moving parts can cause injury if contacted.
- Keep all ***inexperienced*** and ***unauthorized*** people away from the equipment at all times.
- Before start-up, check the hopper and remove all foreign matter and debris.
- **DO NOT** use worn or damaged hose couplings, inspect all hoses and couplings for wear. Replace any worn or defective hose or couplings immediately.
- Keep hands out of the hopper when the engine is running.
- **DO NOT** operate unit with the ***hood open***.
- **DO NOT** disconnect hose couplings or nozzle while under pressure. Relieve pressure by manually activating pressure relief valve at manifold.
- Unauthorized equipment modifications will void all warranties.
- Check all fasteners periodically for tightness. Also check towing tongue bolt, lock nut and wheel lug nuts for wear.
- Test the ***pump's ON/OFF*** switch. The purpose of this test is to shut down the engine.
- Refer to the ***NISSAN Engine Owner's Manual*** for engine technical questions or information recommended by Multiquip for this equipment. Damage to the equipment and or injury to user may result.
- If unit is equipped with ball hitch coupler, use only 2" all steel ball rated for minimum of 6,000 lbs. Use 1" hardened steel pull pin, if not equipped with ball hitch.
- This equipment shall not be towed or operated by individuals who cannot read understand the signs, decals or operating instructions.
- When towing at night, ***always*** have rear tail lights **ON**.
- **DO NOT** tow unit with hopper full of material.
- **DO NOT** tow unit with hoses attached.
- **DO NOT** tow unit in excess of **55 MPH** on highways..

MAINTENANCE SAFETY

- **NEVER** lubricate components or attempt service on a running pump .
- **ALWAYS** allow the pump a proper amount of time to cool before servicing.
- Keep the pump in proper running condition.
- Fix damage to the pump immediately and always replace broken parts.
- Dispose of hazardous waste properly. Examples of potentially hazardous waste are used motor oil, fuel and fuel filters.
- **DO NOT** use plastic containers to dispose of hazardous waste.

TRANSPORTING

- **ALWAYS** shutdown engine before transporting the pump.
- Tighten fuel tank cap securely and close fuel valve to prevent fuel from spilling.
- Drain fuel when transporting pump over long distances or bad roads.

TOWING

- Before towing, check the hitch and secure the safety chain to the towing vehicle.
- When towing, an adequate safety chain must be fastened to the frame, refer to Towing Guidelines.
- Tow only with a vehicle and hitch rated to pull a 6,000 lbs. load.

C-30HDN PUMP — RULES FOR SAFE OPERATION

BATTERY

The battery contains acids that can cause injury to the eyes and skin. To avoid eye irritation, **always** wear safety glasses. Use well insulated gloves when picking up the battery. Use the following guidelines when handling the battery:

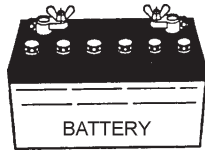

- **DO NOT** drop the battery. There is the possibility of risk that the battery may explode.
- **DO NOT** expose the battery to open flames, sparks, cigarettes etc. The battery contains combustible gases and liquids. If these gases and liquids come in contact with a flame or spark, an explosion could occur.
- **ALWAYS** keep the battery charged. If the battery is not charged a buildup of combustible gas will occur.
- **ALWAYS** keep battery charging and cables in good working condition. Repair or replace all worn cables.
- **ALWAYS** recharge the battery in an vented air environment, to avoid risk of a dangerous concentration of combustible gases.
- In case the battery liquid (dilute sulfuric acid) comes in contact with **clothing or skin**, rinse skin or clothing immediately with plenty of water.
- In case the battery liquid (dilute sulfuric acid) comes in contact with your **eyes**, rinse eyes immediately with plenty of water, then contact the nearest doctor or hospital, and seek medical attention.

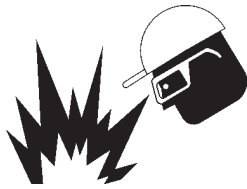

EMERGENCIES

- **ALWAYS** know the location of the nearest **fire extinguisher**.



- **ALWAYS** know the location of the nearest and **first aid kit**.



- In emergencies **always** know the location of the nearest phone or **keep a phone on the job site**. Also know the phone numbers of the nearest **ambulance, doctor** and **fire department**. This information will be invaluable in the case of an emergency.



C-30HDN PUMP — OPERATION AND SAFETY DECALS

Figure 2 displays the operation and safety decals as they appear on the concrete pump, should any of these decals become damaged or unreadable, contact the Multiquip Parts Department for a replacement set.

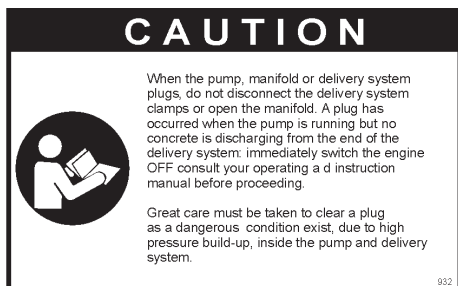

P/N EM932

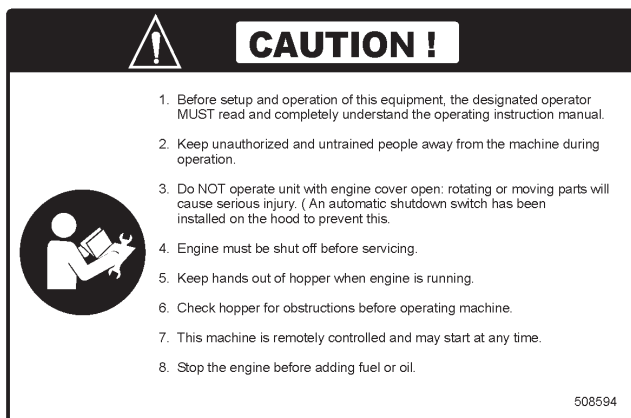

P/N 508594

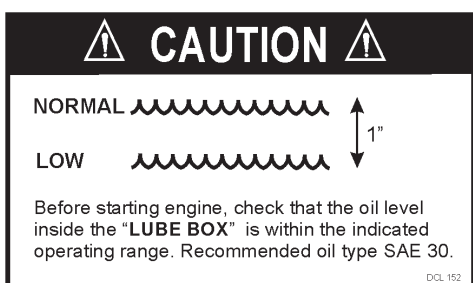

P/N DCL152



P/N EM508594



P/N EM513165



P/N 34536

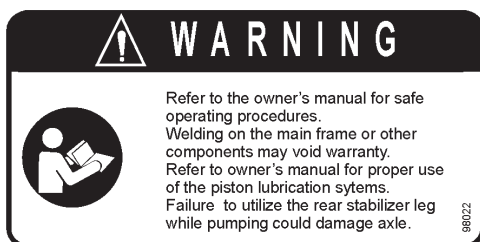

P/N 98022

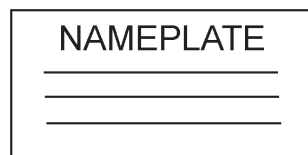

CONTACT MULTIQUIP
SERVICE DEPT.



P/N EM1028

Figure 2. Operation and Safety Decals

C-30HDN PUMP — IMPORTANT HAND SIGNALS

Figure 3 display's the basic hand signals commonly used in concrete pumping operations.



CHUTE UP



CHUTE UP



STOP



START PUMP
SPEED UP



SLOW PUMP
DOWN



STOP PUMP



LITTLE BIT



ADD WATER
4-GALLONS



ALL DONE
CLEAN-UP



DRIVE IN

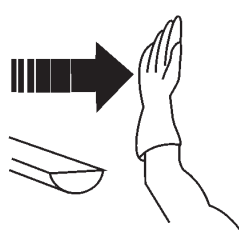

BACK UP

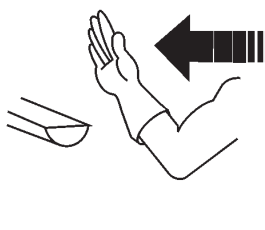

PULL FORWARD



BACK IN

Figure 3. Important Hand Signals

C-30HDN PUMP — PUMP COMPONENTS

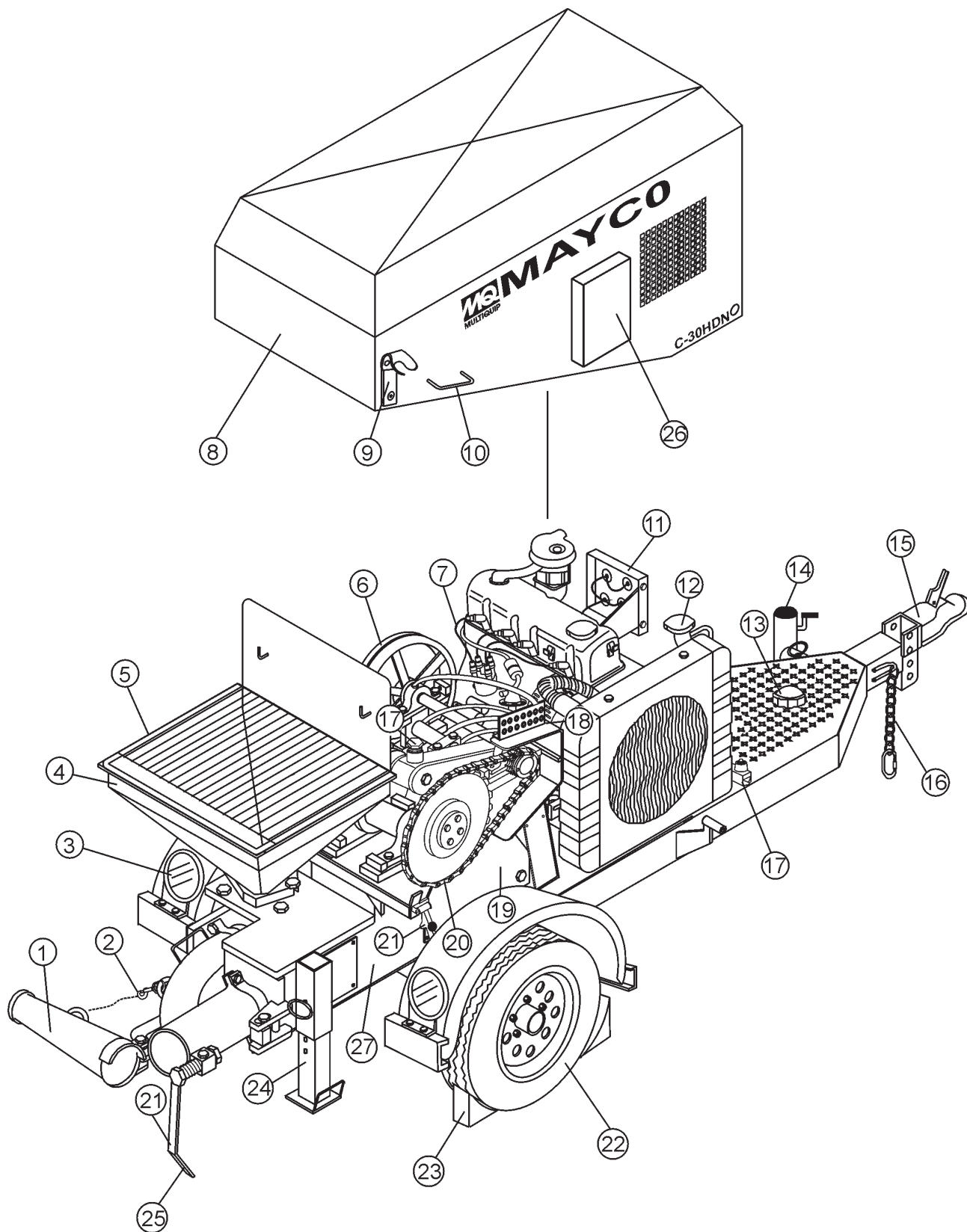

Figure 4. Major Pump Components

C-30HDN PUMP — PUMP COMPONENTS

Figure 4 illustrates the location of the major components for the C-30HDN Concrete Pump. The function of each component is described below:

1. **Discharge Cone** – Connect 3" elbow to this discharge port, then connect 3" x 2" reducer to elbow.
2. **Discharge Cone Safety Latch** – When towing of the pump is required, **ALWAYS** secure the discharge cone to latch located on the manifold.
3. **Rear Running Lights** – **ALWAYS** check and make sure both the right and left running lights are functioning correctly before towing the pump.
4. **Hopper** – Concrete from a Redi-Mix truck is poured into this hopper. The hopper can hold 6.0 cu. ft of concrete. **NEVER** put hands or any other parts of you body into the hopper.
5. **Safety Grill** – The safety grill should be locked at all times when the pump is being towed. Under normal working conditions, raise and place the safety grill on the support hooks which are located on splash guard.
6. **Shaft Pulley V-Belt** – **ALWAYS** inspect the drive shaft V-belt for wear and alignment. A defective or misaligned V-belt can wear prematurely and adversely affect the performance of the pump. Replace with only manufactures recommended type V-belt.
7. **Distributor** – **NEVER** allow concrete, water or any foreign debris to come in contact with the distributor.
8. **Compartment Hood** – **NEVER** operate the pump with the hood removed. Installed on the pump frame is a safety inter-lock device which prevents the engine from starting if the hood is removed or in the up position (open).
9. **Hood Fastener** – When the hood is in the down position, secure the rubber latch to this fastener.
10. **Hood Lift Handle** – Grip this handle, pull upward then back to raise the compartment hood.
11. **Control Box** – Contains the mechanical and electrical components required to run the pump. Below is a list of those components:
 - Throttle Control
 - Choke Control
 - Low Oil Pressure Indicator
 - Battery Charge Indicator
 - Water Temperature Indicator
 - Ignition Switch
 - Remote Connector
12. **Radiator/Cap** – Fill with a water/anti-freeze type solution as recommended in the maintenance section of this manual. **ALWAYS** make sure that the radiator is filled to the proper operating level before starting the engine.
13. **Fuel Tank/Cap** – Fill with unleaded fuel. Fuel tank (cell) holds approximately 11 gallons (42 liters). **DO NOT** top off fuel. Wipe up any spilled fuel immediately
14. **Tow End Jack Stand** – Use this jack stand to level and support the pump.
15. **Tow Hitch Coupler** – Requires a 2-inch ball hitch or a 3-inch pintle. Capable of towing 5,000 lbs. (
16. **Safety Chain** – **ALWAYS** attach safety chain to the towing vehicle. **NEVER!** tow the pump with the safety chain unattached.
17. **Engine Stop Device** – This device will prevent the starting of the engine when the compartment hood is in the **up** position. The compartment hood must be in the **down** position in order for the engine to start.
18. **Grease Port Console** – This console allows for the remote lubrication of components on the pump.
19. **Access Door** – There are four access doors on the pump. Remove these door to gain access to drive and piston assemblies when maintenance is required.
20. **Drive Chain** – Keep this chain properly lubricated and aligned at all times. Lubricate this chain as specified in the maintenance section of this maintenance.
21. **Rubber Latch** – Secure this rubber latch to the hood fastener whenever the pump is in use or being towed.
22. **Tires Ply**– The tire ply (layers) number is rated in letters; This trailer uses 4-ply tires.
23. **Chock Blocks** – Place these blocks (not included as part of your concrete pump package) under each trailer wheel to prevent rolling.
24. **Pump End Jack Stand** – Use this jack stand to level and support the pump.
25. **Discharge Cone Release Lever** – secures the discharge cone to the "Y" manifold; also relieves manifold pressure.
26. **Documentation Box** – Contains engine and pump operation, parts and maintenance information.
27. **Lubrication Box** – This box is empty when shipped from the factory. Please fill with 7 gallons (26.5 liters) of SAE motor oil for first time use. Also check the dual clean-out point on bottom of lubrication box for a secure tight fit.

C-30HDN PUMP — CONTROL BOX COMPONENTS

Figure 5 illustrates the location of the major components for the C-30HDN Control Box. The function of each component is described below:

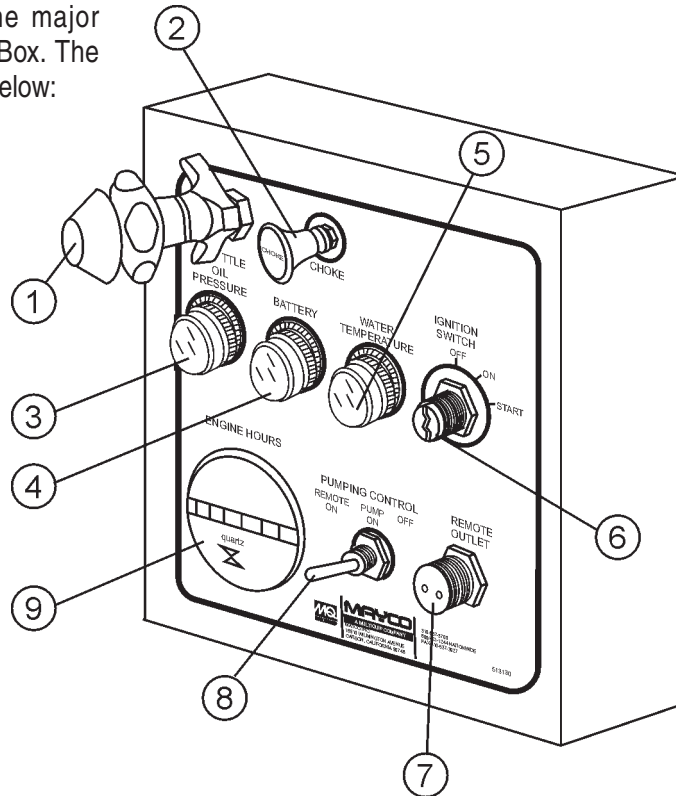
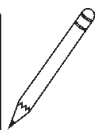
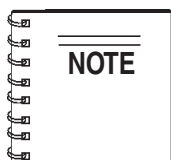

Figure 5. Pump Control Box Components

- 1. Throttle Control Knob** – This is a variable speed type control. Turning the throttle lock (CCW) left unlocks the throttle allowing the throttle control cable to be pulled out to the desired position. Once the desired throttle position (speed) has been achieved, turning the throttle lock to the (CW) right locks it in place. Use the fine tune adjustment knob to fine tune the engine rpm's.

To place the engine in idle, press the top button inward all the way.



ALWAYS unlock the throttle control before it is pushed in because if this is not done first, possible damage could result to the locking mechanism.

- 2. Choke Knob** – When the starting of an cold engine is required, open choke by pulling choke control to extreme out position. Let engine run for 3-5 minutes, then push choke knob all the way in (close position).
- 3. Oil Pressure Indicator Lamp** – In the event of low oil in the engine crankcase or low oil pressure, the oil "Oil Pressure Lamp" indicator will be lit. **STOP** the engine immediately if this lamp is lit. **NEVER** run the engine when this lamp is on.

- 4. Battery Charge Indicator Lamp** – Indicates if the electrical system is charging properly. If the "**Battery Charge Indicator Lamp**" is lit, this is an indication that the charging system is malfunctioning. **STOP** the engine and remedy the electrical charging problem.
- 5. Water Temperature Lamp** – In the event of high engine water temperature (220 degrees Fahrenheit), this lamp will be lit. **STOP** the engine immediately if this lamp comes on. **NEVER** run the engine when this lamp is on.
- 6. Ignition Switch** – Insert the ignition key here to start the engine. Turn the key clockwise to the **ON** position, then continue turning clockwise to the **START** position and release. To stop the engine turn the key fully counter-clockwise to the **STOP** position.
- 7. Remote Control Input Connector** – Insert the remote control input cable into this connector.
- 8. Pumping Control Switch** – This 3-position switch controls the pumping of the pump. The **left most** position is for use with the remote control unit, the **center** position is for normal pumping operation, and the **right most** position (OFF) prevents pumping.
- 9. Hourmeter** – Display's the number of hours the pump has been in use.

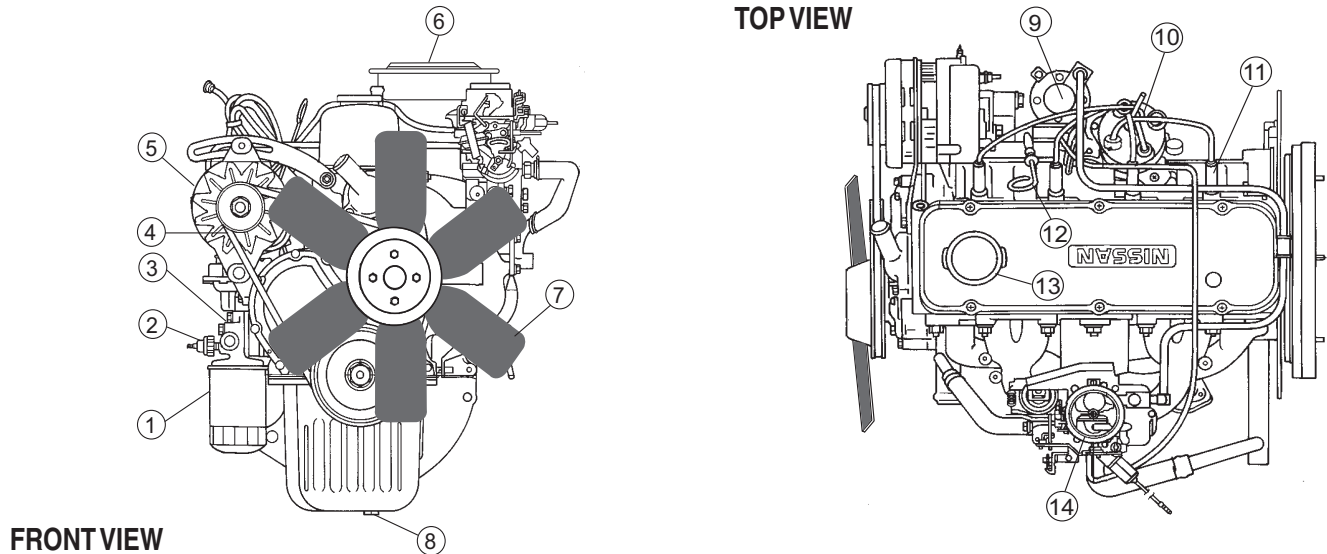
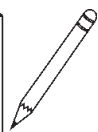
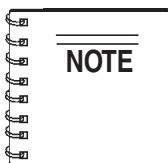

Figure 6. Nissan Model A15 Basic Engine Components

Figure 6 illustrates the location of the basic components for the NISSAN A-15 Engine. The function of each component is described below:

1. **Oil Filter** – Replace this filter as recommended in the maintenance section of this manual
2. **Oil Pressure Switch** – In the event of low oil level, this switch will shutdown the engine.
3. **Starter Motor/Solenoid** – **NEVER** allow concrete or any foreign debris to come in contact with the starter motor/solenoid.
4. **Fan V-Belt** – **ALWAYS** make sure that V-belt is properly tensioned. A loose or defective V-belt can adversely affect the performance of the pump.
5. **Alternator** – Provides power to the electrical system. Replace with only manufactures recommended type alternator.
6. **Air Cleaner** – Prevents dirt and other debris from entering the fuel system. Remove wing-nut on top of air filter cannister to gain access to filter element. Replace with only manufactures recommended type air cleaner.
7. **Cooling Fan Blades** – Make sure that the blades of the cooling fan are not **bent or broken**. A damaged fan blade can cause the engine to run hot and overheat.
8. **Crankcase Drain Plug** – Remove this plug to drain engine oil from the crankcase. Replace with recommended engine oil as specified in the maintenance section of this manual.
9. **Fuel Pump/Fuel Filter** – Replace or clean the fuel pump or fuel filter as specified in the maintenance section of this manual.
10. **Distributor** – **NEVER** allow concrete or any foreign debris to come in contact with the distributor.
11. **Spark Plug** – Provides spark to the ignition system. Set spark plug gap to 0.6 - 0.7 mm (0.028 - 0.031 inch). Clean spark plug once a week.
12. **Dipstick** – Remove this dipstick to determine if engine oil is low. Maintain oil level at the "H" marking on the dipstick. **NEVER** run engine with low oil.
13. **Oil Filler Port Cap** – Remove this cap to add engine oil to the crankcase. Fill with recommended type oil as specified in the maintenance section of this manual
14. **Carburetor** – **ALWAYS** keep dirt, dust, and any foreign debris from entering the carburetor. Clean carburetor as recommended in the maintenance section of this manual.



Operating the engine without an air filter, with a damaged air filter, or a filter in need of replacement will allow dirt to enter the engine, causing rapid engine wear.

C-30HDN PUMP — GENERAL INFORMATION

The following operating principles and operating suggestions should prove helpful in the successful operation of your concrete pump. Your new "small line" concrete pump has been designed to give you many years of service when operated properly. A study of the following paragraphs is important to the successful operation of your new Direct-flo Concrete Placer.

All concrete pumps require a high level of operator skill and more frequent service than most of the other construction equipment. The highly abrasive nature of concrete under pressure makes it extremely important that expendable wear components be inspected at regular intervals between jobs to prevent having to replace these items during a pour.

Experience has proved that inconsistency of batched concrete mixes and frequent moving of the line requires the operator to be readily available at all times during pumping to stop the pump and prevent abuse to the unit which may occur if unexpected blockages develop.

PUMP MIX GUIDELINES

When ordering concrete, be certain to advise the concrete supplier that you require a "pump mix". The Direct-flo manifold will pump a wide variety of materials, but certain basic principles must be followed to assure successful pumping, as follows:

Generally speaking, the washed concrete sand and #4 aggregate (pea gravel) should conform to A.S.T.M. standards in regard to sieve analysis. Sands in some areas are washed clean of the #100 and #200 mesh fines, which results in separation and jamming in the manifold while pumping under pressure.

If this condition develops, check with your concrete suppliers engineers and get their recommendations for supplementing the lack of the fines. The use of locally accepted ad-mixes may be required. (For example, Pozzoloth, Bentonite Clay, Plastiments, etc.) When properly prescribed, additives form the plastic paste sometimes necessary to hold the cement and aggregate together.

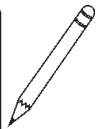
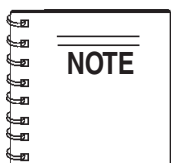

If jamming conditions in the pump or hose occur for any reason at all, **DO NOT** attempt to use more power to correct the condition.

Determine the cause of jamming, correct it and resume pumping. Trying to force material through under jammed conditions may result in damage to the drive system, thus voiding any warranty services.

As a general rule, the use of approximately six sacks of cement, 70% washed concrete sand and 30% #4 pea gravel per yard of concrete will result in a pumpable mix. The ideal nature of sand and rock in certain areas may permit you to increase the percentage of rock or adjust the mix considerably to meet the job requirements. When possible, you may experiment with various mixes in your area to determine the degree of versatility of the Direct-flo Pump.

Uniform gradation of the washed concrete sand and the 1/2" minus aggregate along with sufficient cement content and water are important to a successful pump operation.

A recommended pumpable mix design would be 70% sand and 30% aggregate-cement content to be a minimum of 6 sacks. (564 lbs.)

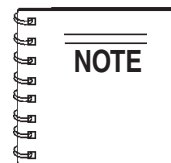

Your local sand and rock engineers will give you the S.S.D. weights of sand and rock required in your local area which will yield one cubic yard per the above recommendation.

SAMPLE DESIGN MIX-3000 PSI 3/8" SLUMP 4"- 5"

Type II Cement	6.49 sack/cu. yd	611 lbs.
Sand	Sat. Surf. Dry	2000 lbs.
#4 Gravel	Sat. Surf. Dry	864 lbs.
#3 Gravel	Sat. Surf. Dry	0 lbs.
Water	48 Gallons	400 lbs.
	Total Weight	3,906 lbs
Admixture WRDA-79		26 oz.
Water	7.40 gal/sack	

Test laboratory data has proven in many areas that the above mix guidelines have produced concrete rated at 3000 psi (28 day test) and upwards of 5000 psi with an increase in cement.

In some areas where the gradation of sand and rock is ideal and sufficient cement is used along with admixtures, the Mayco small line concrete pump will handle up to a 50-50 ratio of sand and rock.

When the mix is designed for wet gunning applications, it is normal to increase the cement (up to 7.5 or 8 sacks) and change the sand to rock ratio to 85% sand and 15% rock.

The Mayco concrete pump will valve efficiently when using cellular-foam concrete mixes upwards of 70 lbs. per cubic foot wet density. (Below 70 lbs. materials (roof decks) the valving becomes inefficient.)

The MAYCO concrete pump has one main pumping piston which is valved by means of two ball checks. (**A** inlet, and **B** outlet.)

The secondary piston is used as a compensator piston to smooth out the pulsations of a single piston action. Note: The compensator will not start operating until material is pumped into the line and back pressure develops.

The **compensator spring**, which is installed on the compensator piston rod, deflects with each piston stroke. This "**spring cushion**", in conjunction with the cam profile, produces and uninterrupted smooth flow of material under average pumping conditions.

The pumping cylinder (Figure 7) retracts drawing the material past the ball (**A**) and filling the cylinder. The compensator piston is pumping the material out to the nozzle and causing ball (**B**) to seat preventing the material from returning to the pumping cylinder intake.

An automatic, centrifugal clutch is installed to engage and disengage the pumping action without stopping or starting the engine. The **centrifugal clutch** is set at 1100 R.P.M. The engine idle speed is approximately 875 R.P.M.; therefore, the clutch is completely disengaged at idle. The throttle settings while pumping should always maintain an engine R.P.M. high enough to prevent the clutch from slipping and burning the clutch lining.

The return spring which is installed on the rocker arm, is installed to eliminate shock and stress between the cam roller and the cam weldment when the pump is in operation. If the return spring is removed or replaced for any reason, maintain the backing plate dimension of 3" as shown on Figure 3, to produce the proper pre-loading of the spring for a smooth performance.

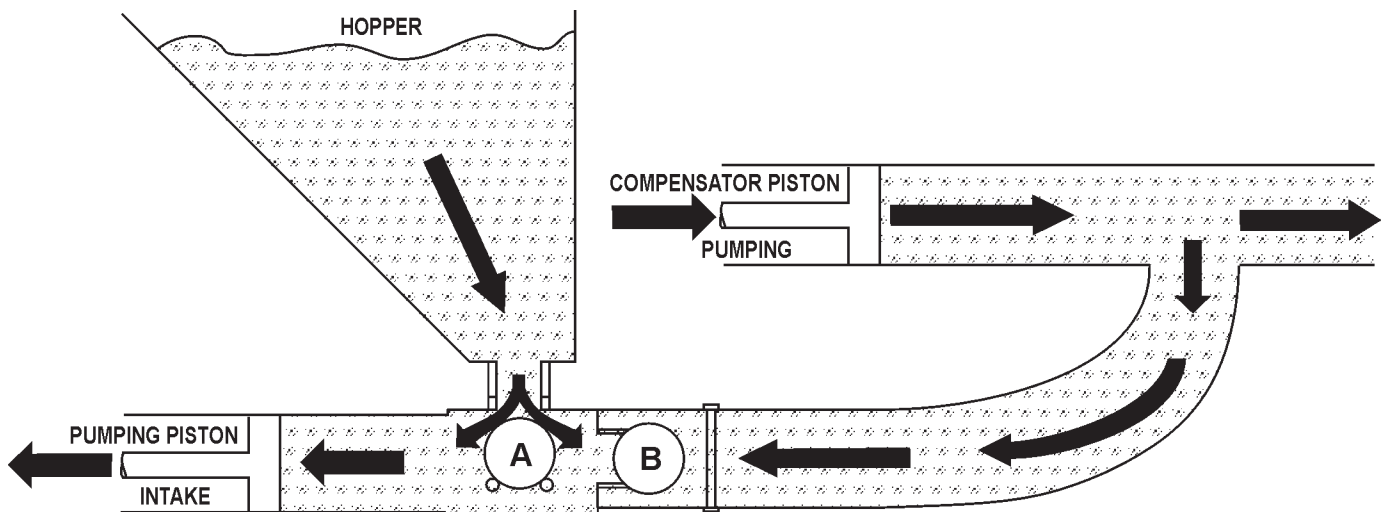

Figure 7. Pumping Cylinder

C-30HDN PUMP — HOW IT WORKS

The pumping piston (Figure 8) is forcing the material past ball (B) and out to the nozzle, also seating ball A so that the material will not flow back to the hopper. This action also fills the compensating piston for the next stroke.

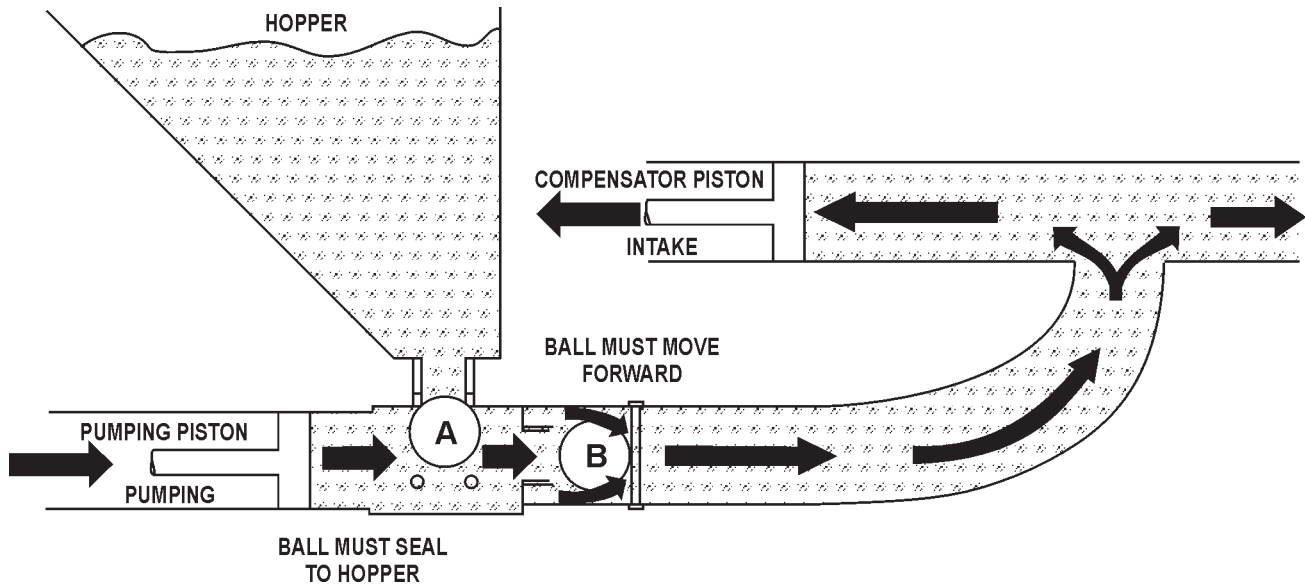

Figure 8. Pumping Pistons

Figure 9 shows the relationship between the return spring, the compensator spring and the rocker arm to maintain a smooth performance. **DO NOT** tighten the bolt (Item 1) completely, the rod end must be able to move.

The return spring is installed to eliminate shock and stress between the cam roller and the cam weldment when the pump is in operation. If the **return spring** is removed or replaced for any reason, maintain the backing plate dimension (3-inches) as shown to produce proper pre-loading of the spring for a smooth performance.

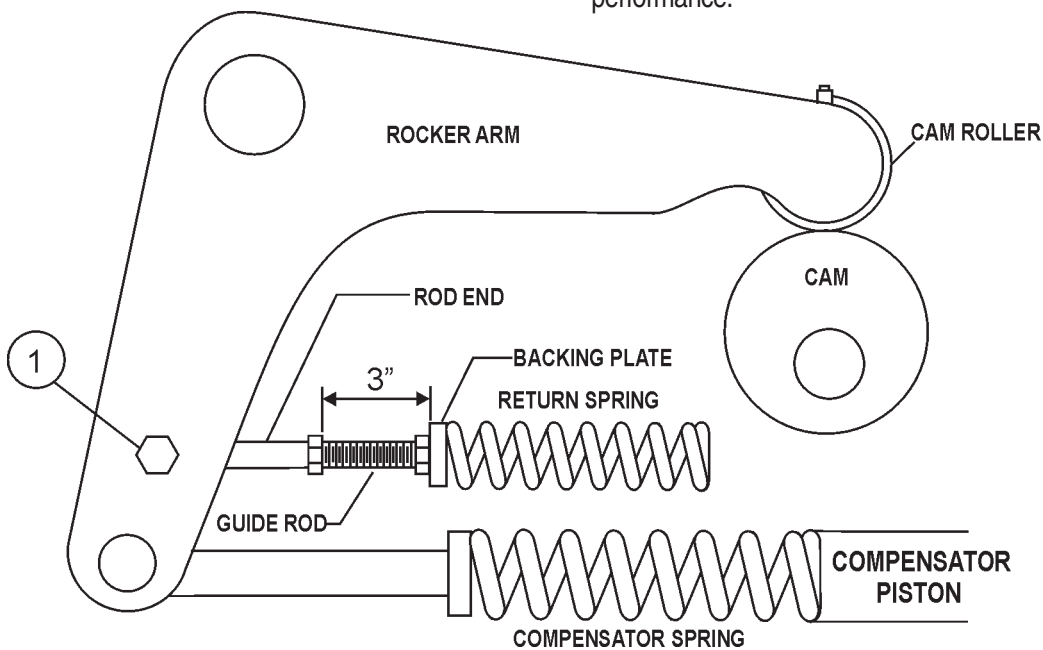

Figure 9. Return Spring, Compensator Spring and Rocker Arm Interaction

C-30HDN PUMP — INSPECTION

CAUTION - General Safety Guidelines

NEVER operate the pump in a confined area or enclosed area structure that does not provide ample **free flow of air**.



ALWAYS wear approved **eye** and **hearing** protection before operating the pump.

NEVER operate the pump's engine with the engine hood removed. The possibility exists of **hands, long hair, and clothing** becoming entangled with the V-belt, causing injury and bodily harm.



NEVER place hands or feet inside the **hopper**. **ALWAYS** make while the engine is running. **ALWAYS** shut-down the engine before performing any kind of maintenance service on the pump.

Before Starting

1. Read safety instructions at the beginning of this manual.
2. Removing any dirt and dust that might have accumulated around the engine cooling air inlet, fuel injection system.
3. Check the air filter for dirt and dust. If air filter is dirty, replace air filter with a new one as required.
4. Check fuel injection system for external dirt and dust. Clean with dry compressed air.
5. Check fastening nuts and bolts for tightness.
6. Connect Battery
7. Make sure hopper is free of dirt and foreign debris (large objects over 2-inches)
8. Make sure radiator is filled with proper amount of anti-freeze water solution (50/50).
9. Make sure all hose lines are in good condition and are working properly.

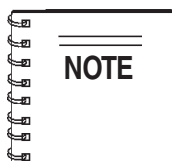

Reference manufacturer engine manual for specific servicing instructions.

Engine Oil Check

1. To check the engine oil level, place the pump on secure level ground with the engine stopped.
2. Remove the dipstick from its holder (Figure 10) and wipe it clean.

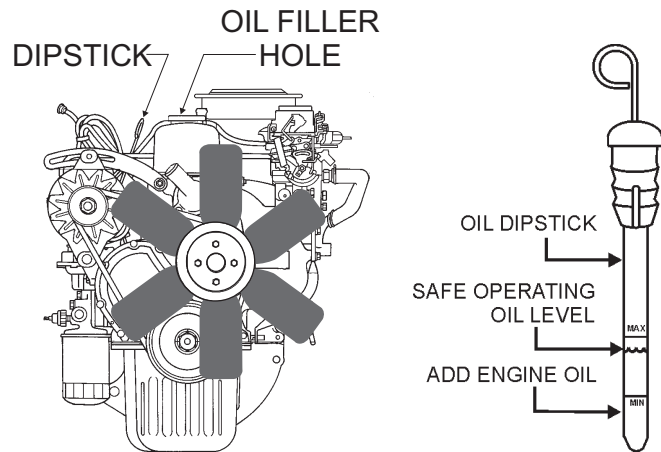

Figure 10. Engine Oil Dipstick

3. Check the engine oil level as shown on the dipstick.
4. If the engine oil level is low, add oil through the engine oil filler hole (Figure 12) with the recommended oil type (Table 3). Maximum oil capacity is 3-3/8 quarts (3.2 liters).

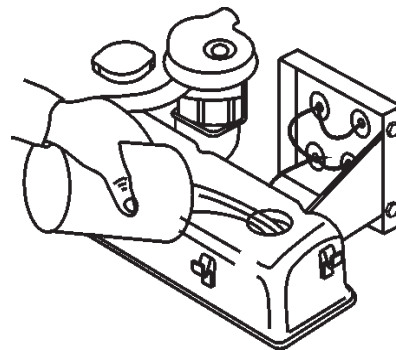

Figure 11. Engine Oil Filler Hole

Table 3. Oil Type

Season	Temperature	Oil Type
Summer	25°C or Higher	SAE 10W-30
Spring/Fall	25°C~10°C	SAE 10W-30/20
Winter	0°C or Lower	SAE 10W-10

C-30HDN PUMP — INSPECTION

Gasoline Check

1. Remove the gasoline cap located on top of fuel tank.
2. Handle Fuel in a safety container. If the container does not have a spout use a funnel.
3. Visually inspect to see if fuel level is low. If fuel is low, replenish with unleaded fuel. When refueling, be sure to use a strainer for filtration. **DO NOT** top-off fuel. Wipe up any spilled fuel.
4. Pay attention to the fuel tank capacity when replenishing fuel. Refer to the fuel tank capacity listed in Table 5.

WARNING - Explosive Fuel



Gasoline is extremely flammable, and its vapors can cause an explosion if ignited. **DO NOT** start the engine near spilled fuel or combustible fluids. **DO NOT** fill the fuel tank while the engine is running or hot.

DO NOT overfill tank, since spilled fuel could ignite if it comes into contact with hot engine parts or sparks from the ignition system. Store fuel in approved containers, in well-ventilated areas and away from sparks and flames. **NEVER** use fuel as a cleaning agent.

DO NOT smoke while refueling, motor fuels are highly flammable and can be dangerous if mishandled.

Lubrication Box

The model C-30HDN model features a fully enclosed **lubrication box**, which utilizes the "**SPLASH**" method of lubrication.

Before using your new pump, 7 gallons of SAE 30 motor oil must be added directly into the lubrication box. Visually inspect the oil in the lubrication box by making sure the oil is at the correct operating level as indicated by the dip stick (Figure 16).

Also reference the oil level decal (Figure 17) adjacent to the lubrication box.

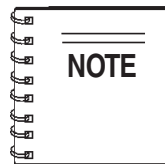

Make sure the pump is on a secure level surface when checking the oil level inside the lubrication box.

CAUTION - Checking Lubrication Oil Levels

The oil level **must** be **checked daily** to ensure adequate oil level and oil cleanliness.

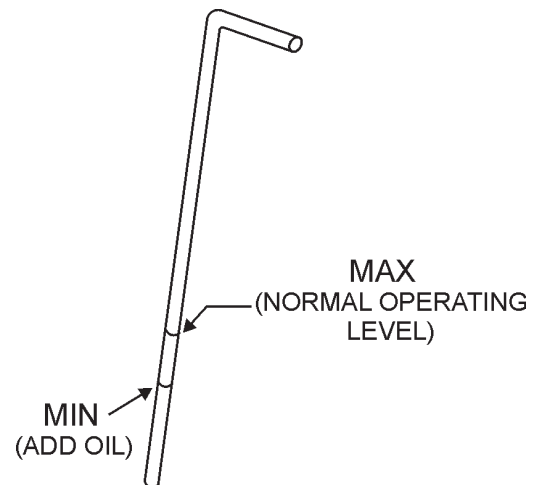

Figure 16. Lubrication Box Dipstick

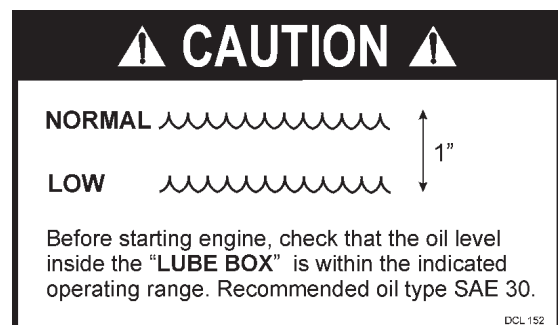

Figure 17. Lubrication Box Oil Caution Decal

Checking Engine Coolant Level

1. Remove the radiator cap, and check the cooling water level inside the radiator (Figure 18).
2. Maintain water/coolant level at top of radiator coils.

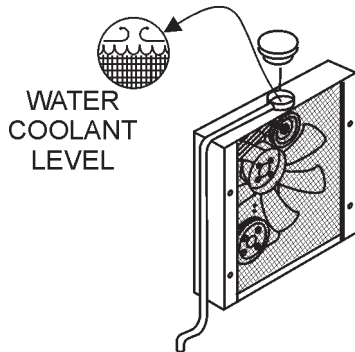

Figure 18. Radiator Coolant

WARNING - Burn Hazards

NEVER remove the radiator cap when the engine is **HOT!** Allow the engine to cool before remove the cap.



3. Check the radiator and hoses for any signs of leakage.
4. If cooling water is dirty, flush the cooling system.
5. When using antifreeze, mix the antifreeze coolant with water. Observe the instructions on the antifreeze container. Usually a 50/50 mixture is a good choice.
6. When replacing the radiator cap, be sure to fit it securely back onto the radiator. (If replaced loosely or incorrectly, the cooling water will quickly evaporate, causing the engine to overheat.)

V-Belt Deflection

1. Visually inspect the V-belt for cracks, fraying, wear or oiliness.
2. Make sure V-belt does not the bottom the pulley groove.
3. Check the V-belt tension (Figure 19) by pushing midway through the two pulleys. The V-belt deflection should be between .300 to .472 inches (8 to 12 mm).

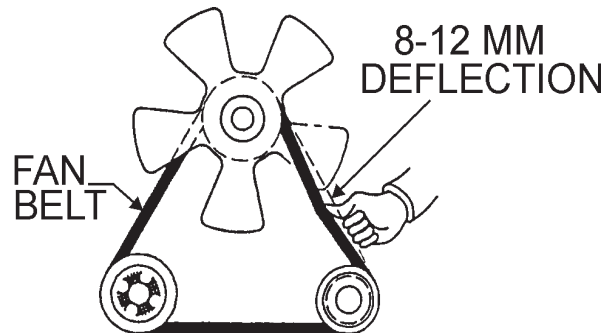

Figure 19. V-Belt Deflection

C-30HDN INITIAL START-UP

Starting

CAUTION - General Safety



DO NOT attempt to operate this concrete pump until the Safety, General Information and Inspection sections have been read and understood.

1. Turn the inner most knob counter clockwise to unlock the **throttle cable** (Figure 17).

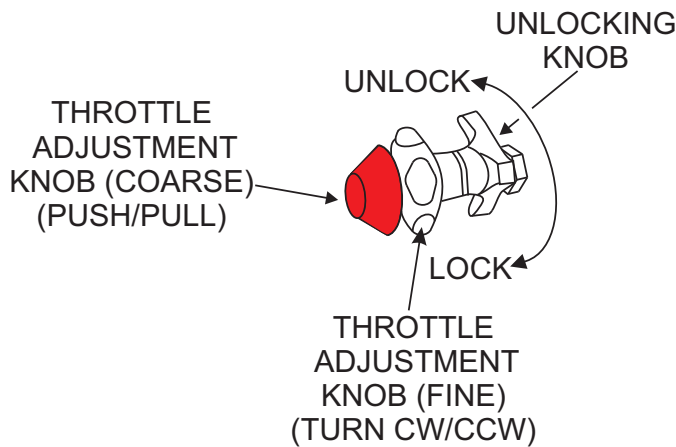

Figure 17. Throttle Control Knob (Un-locking)

2. Push the outermost button inward, then pull out about half way. This will set the throttle at half speed (Figure 18).

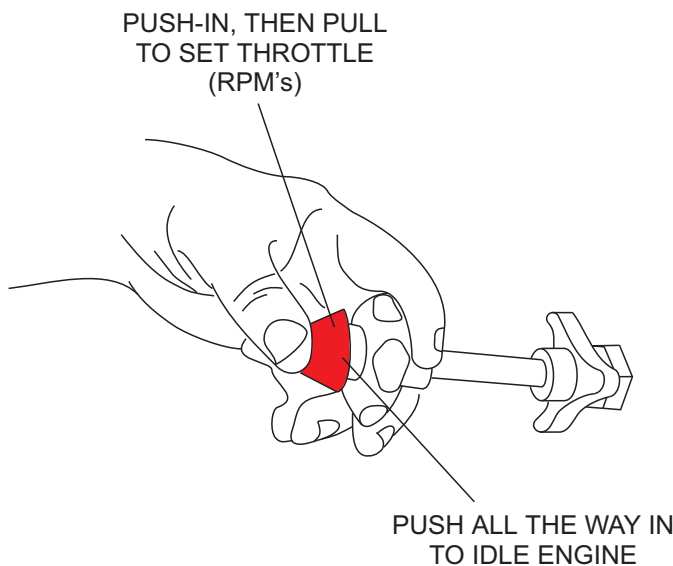

Figure 18. Throttle Control Knob (RPM Adjust)

3. Pull the **choke knob** (Figure 19) outward about half way. In cold weather, start the unit with the choke in the fully closed position. In summer time or when the engine is warm, the unit can be started with the choke halfway or completely open



Figure 19. Throttle Control Knob

4. Place the **pumping control switch** (Figure 20) in the **OFF** position.

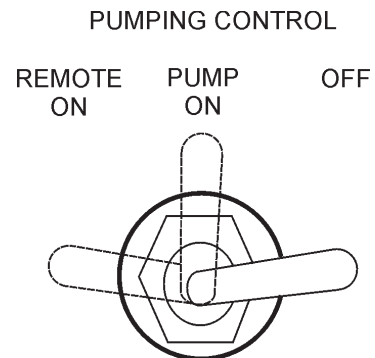

Figure 20. Pumping Control Switch (OFF)

5. Insert the ignition key into the **ignition switch** and turn the key to the **ON** position, then to the **START** position (Figure 21). Release the key when the engine starts.

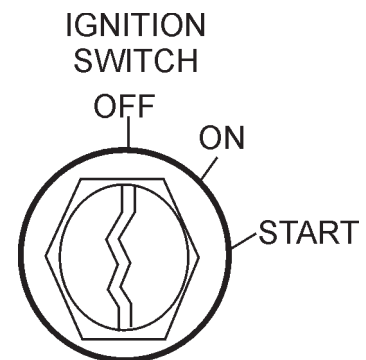

Figure 21. Ignition Switch

- Verify that the **oil pressure**, **battery** and **water temperature** status lamps (Figure 22) are all **OFF**. If any of these lamps are **ON**, stop the engine and correct the problem.

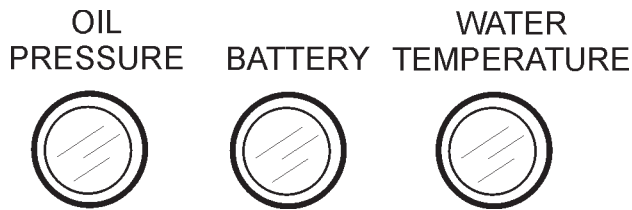

Figure 22. Control Box Status Lamps

- Let the engine run for 3-5 minutes before putting pump into operational use. Push the **choke knob** in all the way.
- Listen for any abnormal sounds. If any mechanical or electrical problems exists, **STOP** the engine and correct the problem.
- To begin pumping concrete, place the **pumping control switch** in the **ON** position (Figure 23).

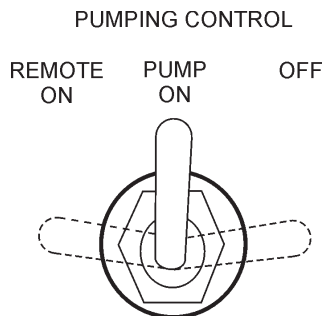

Figure 23. Pumping Control Switch (OFF)

System Shut-Down

- Place the **pumping control switch** in the **OFF** position (Figure 20).
- Push the **throttle control** in all the way (idle). Let the engine run at idle speed for 3-5 minutes.
- Turn the **ignition key** (Figure 21) to the **OFF** position.
- Clean pump as referenced in the maintenance section of this manual.

C-30HDN PUMP — OPERATING INFORMATION

OPERATING SUGGESTIONS

1. A well-planned location for the pump and routing of the hose before starting a pour may save subsequent moves throughout the job.
2. Before concrete is discharged into the hopper, it is suggested that 3 to 4 gallons of water be sprayed into the hopper, followed by approximately 5 gallons of a creamy cement and water slurry (1/2 bag of cement to 5 gallons of water). This procedure lubricates the hose and prevents separation and blockages in the hose.

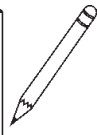
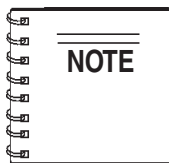

Getting the concrete to flow through the hose at the start of the pumping cycle can be one of the most critical operations of the pour.

Manually operate the throttle when starting, **NOT** remotely.



CAUTION - Inspect Hose Lines

If hoses or lines are **blocked** for any reason, or if the lines are **kinked** when starting up or during the pumping cycle, the pump pressure could straighten out the kink or force out the blockage. This rapid surge of material could cause the lines to **whip** or **move** in a manner that could cause injury to personnel.

Inspect the lines at all times to prevent the above conditions

3. It is important that once the slurry procedure is completed, and you have started concrete flowing through the hose, do not stop the pour until all the slurry is pumped out and the concrete has reached the end of the hose. The only time to stop the pump at the start is if a blockage occurs.
4. When the pump is stopped for any reason during a pour; e.g., moving hose, waiting for redi-mix truck, the following suggestions are offered:
 - A. Leave the hopper full of concrete at the time of shutdown. It is important not to let the **redi-mix** driver wash too much water into the hopper, as this could cause separation of the concrete in the hopper.
 - B. If the **shutdown** period exceeds 2 to 3 minutes, turn off the engine so the vibration does not separate the mix in the hopper which can cause a blockage in the manifold when the pump is started.

- C. If it is necessary to wait 10 minutes or more for another load of concrete, it is wise to start the pump and pump 6 or 8 strokes every 5 minutes to prevent setting of the mix in the system. If waiting time is excessive, it would be wise to wash out the pump and hoses and start over when the new truck arrives.
- D. When pumping stiff mixes and there is waiting time between redi-mix trucks, it is advisable to add some water to the last hopper of material and “hand mix” to ensure an easier start with the following load.
- E. When the pumping job requires a stiffer mix, the following method is suggested for starting: Take a water hose with a nozzle on it and apply water with a fine spray to the concrete as it comes down the redi-mix chute into the pump hopper after the slurry procedure is completed and you are ready to start pumping.

Using this procedure will make it easier to pump through the clean hose.

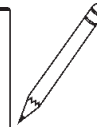
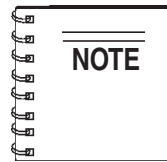

Once the concrete has reached the end of the hose, do not apply any more water in this manner as this procedure is used on the start only.

- F. Hose sizing is very important: We strongly recommend on harsh mixes, vertical pushes, stiff concrete, shotcrete, long pushes, that a 2 - 1/2" line be used as far as possible. The advantages of using the 2 - 1/2" line are improved pumpability, less pumping pressure and less wear on the pump.
5. Following the pump operation, proper wash out of all materials or “build-up” within the pump manifold and hoses will prevent problems when starting the next job.
 6. A thorough inspection of the drive components and greasing of all bearings after each job will ensure adequate lubrication and service to the pump which is normally operating in wet, gritty conditions.

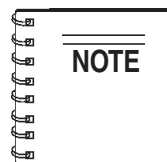

Over-greasing any **bearing** on your Mayco pump will not damage the bearing.

C-30HDN PUMP — OPERATING INFORMATION

WARNING - Line Blockage

If a blockage occurs, find where it is and clear it before further pumping. **DO NOT** increase the engine speed to clear the blockage. Increasing the engine speed will only compound the problem.

If you repeatedly pull the throttle all the way out and try to force your pump to push through **blockages**, due to separation of material in the hose or manifold, you will soon have breakdowns and costly repairs which are not covered under warranty.

WARNING - Clear Hopper Before Moving

It will be necessary at times to move your pump from one job site location to another. Before moving the pump, make sure to pump the remaining concrete out of the hopper.

Moving the pump with a **full hopper** of concrete can cause severe damage or breakage of the axle and axle springs, excess strain and pressure on the hub and bearing assembly.

Pumping Tips

1. **The effects of heat and excessive time on concrete:** Hot concrete, commonly referred to as a hot load, is concrete that has been in the redi-mix truck in excess of 2 to 3 hours. On a hot day, this amount of time is even less. A brief explanation of why heat and time affect concrete:

Concrete starts setting by drying up through a chemical reaction. The catalyst to this reaction is heat. When pumping a hot load, it is important to remember that when you have to stop pumping for any reason, add water to the concrete in the hopper and hand mix and move concrete in the hose every 5 minutes. If the shut down time becomes too long, wash out immediately.

2. **ADMIXTURES:** Admixtures that are designed into the concrete mix by the redi-mix company or an architectural engineering company. This section lists common admixtures and a brief explanation of their functions:
 - A. **Pozzolith 300** – or the equivalent acts as a water retarder and a lubricant. On a lean mix, long pushes, stiff mixes, and vertical pushes, Pozzolith 300R helps pumpability.
 - B. **MBVR** – air entraining, acts as a lubricant.

- C. **Calcium Chloride** – commonly referred to as C.C., is used as an accelerator. When pumping a load with calcium chloride, it is recommended that you wash out if the waiting time between delivery trucks becomes too long.
- D. **Super Plasticizers** – acts as an accelerator. The concrete will look very wet after the super plasticizer is added, but will begin to set up very fast. Wash out immediately if you do not have a truck waiting. Super plasticizers are used mainly on commercial jobs.
- E. **Red Label** – acts as a water retarder and an accelerator. Red label will be used mainly on commercial jobs.
- F. **Fly Ash** – is used to help increase the strength of the concrete and decrease the cement content per yard. This is one of the most common admixtures used.

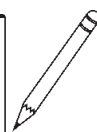
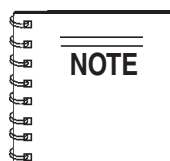

All admixtures will be shown on the redi-mix concrete ticket. Before starting the pumping job, ask the driver of the redi-mix truck to see the concrete ticket and note the admixtures that exist and take the proper action.

3. When pumping long distance or pumping stiff mixes, you can expect a drop in volume compared to shorter lines and wetter mixes due to the change in valve efficiency or cavitation.
4. Leaking manifold seals or hose coupling gaskets which leak water can cause separation and subsequent jamming at that point.
5. Damaged hoses with internal restrictions can cause blockages.
6. If a blockage occurs in a hose, “walk the hose” until you find the point of trouble. The hose will be soft immediately past the blockage. If this happens at the start, disconnect the hose at the first coupling past the blockage.
 - A. Elevate the hose at that point with the blockage area hanging down.

WARNING - Line Under Pressure

Use **extreme CAUTION!** The hose line is under pressure and a rupture can cause **serious injury**.

- B. Using a hammer, you can pound the down-stream edge of the packed area until it is free to flow. Shake all of the sand and gravel out to the end of the hose.
- C. Before reconnecting the hose, start the pump and run a small amount of concrete out to the end of the hose. This will assure that all of the separation is out of the hose.

C-30HDN PUMP — OPERATING INFORMATION

7. The manifold is plugged if the volume at the discharge end of the hose stops, and the hose is soft. The drive belts will start to slip and the engine will lugdown.

Follow steps 7A through 7J to un-plug a clogged manifold.

WARNING - Clearing A Plugged Manifold

Due to pressure build-up inside the manifold, great care must be taken when clearing a plugged manifold.

- A. **STOP** the pump and switch **OFF** the engine.
- B. **DO NOT** open any of the delivery system joint clamps.
- C. The senior operator must warn all others to stand at least 20 feet away from the pump and turn their heads away from the manifold.
- D. The operator must position himself/herself away from the hinged side of the manifold.
- E. Wearing safety glasses, grasp the clamp arm weldment and carefully pull it open to the primary (safety) position. **STOP** and wait approximately 20 seconds. This will allow the pressure to release.
- F. After the pressure has been released, open the clamp arm weldment and swing the hinged discharge cone open.
- G. Remove blockage with a round 2-foot length of reinforcing steel rod. Flush the manifolds with water. Make sure the 3 x 2 in. reducer is clear of any blockage before closing the discharge cone.
- H. After the blockage has been cleared and the pump manifold has been thoroughly flushed with water, close the hinged discharged cone and lock into place.
- I. Before reconnecting hose to the reducer, start the engine and pump two or three shovels of concrete through the reducer. This will insure that all the blockage has been cleared.
- J. Shake out around 2 feet of concrete before reconnecting hose to pump. After this is done, connect hose to pump and resume the pumping operation.

8. **Avoiding Setting of the Mix in the System**

To avoid setting of the concrete mix in the system when waiting more than 30 minutes between concrete loads, flush the system depending on job factors (such as presence of accelerators and job site temperature) and your particular mix design.

Clearing a Mix from the System

If, for any reason, the mix should set up in the system, the following procedure is suggested:

CAUTION - Hose Pressure Hazard

When disconnecting hoses, use **extreme CAUTION!** The hose is under pressure!

1. Disconnect the hoses from the pump and wash the pump out immediately. For example:, if you had 200 ft. of system out, you would disconnect each hose.
2. Reconnect the first hose and fill the hopper with water. **DO NOT** try to push all the concrete out of all of the hose lines at one time.
3. Clean it out by pushing water through the first hose off the pump, then continue progressing through all the hoses, until all the system is clean.
4. If waiting time is excessive, it would be wise to wash out the pump and hoses and start over when the new truck arrives. This can be avoided by being observant to the pump and system, also taking into consideration the above factors affecting the mix.

Down-Hill Pumping

Downhill pumping can be difficult on some jobs. The slurry procedure would be the same as explained on the pages titled Operating Suggestions. It is suggested that a sponge 2"x 4"x 6" be placed in the hose before the start of pumping. Wet the sponge before placing it in the hose.

The reason for using the wet sponge is to keep the slurry from running too far ahead of the concrete and so reducing the possibility of separation. When the pump is stopped, the material can flow slowly down, due to gravity, and cause the hose to collapse.

When pumping is resumed, you can expect a blockage at the point of hose collapse. To prevent this from happening, the hose can be "kinked off" at the discharge end when the pump is stopped to prevent the gravity flow of the material in the hose.

The use of stiffer mixes when pumping down-hill will decrease gravity flow of the material in the hose and will assure a smoother operation between the cam roller bearing and cam plate. As with any job, make sure that the hose and the couplings are in good workable shape.

Vertical Pumping

When pumping vertically up the side of a building, above 40 feet, we would recommend the installation of **steel pipe** securely fastened at intervals as necessary to support the pipe. Ninety degree, long radius pipe sweeps should be installed at the top and bottom of the steel line.

Use a 25 ft. hose, or short section, off the pump; and for the balance of the horizontal distance to the vertical line, use steel pipe. This type of installation has been satisfactory on many jobs being pumped in excess of 100 feet high. Line pressures are always less using steel pipe as compared to hose.

When pumping vertically using **all hose**, it is recommended not to go higher than 50 feet with hose. The hose should be tied off at intervals of 10 feet, if possible. Special attention should be given when tying the hose off at the top as the hose will have a tendency to stretch when filled with concrete. This will increase the possibility of a blockage at the point where the hose is tied off. To avoid this, a long radius of 90 degree elbow is recommended. The suggested place to tie off is on the hose, under the clamp.

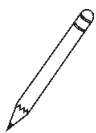
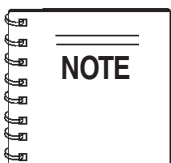

It is strongly recommended that steel pipe be used on **ALL** vertical pumping for safety and convenience.

Valve Seats

If the volume at the end of hose starts to decrease gradually and eventually almost stops, it is quite likely that the **valve seats** have had excessive wear and need replacement. Once they have reached a certain wear point, they may "channel out" rapidly and material will reciprocate past the ball on each stroke.

The hollow **steel ball** should be replaced when it starts to show dents or appears to be badly worn. Sand and aggregate materials in some areas are extremely sharp and hard and therefore highly abrasive. Under these conditions when pumping stiff mixes, or to high elevations which cause line pressures, it will be noted that valve components may have short wear life.

If this condition exists, it is advisable to remove the manifold only, and inspect the lower seat at the end of each day. If it appears that the seat is beginning to "channel out, replace before starting the next day's pour.

The upper valve seat can be inspected after each washout by running your finger around lower edge of seat where the ball makes contact. You can reach this from the inside of the hopper. Be sure that the engine is turned off.

Pulsation

A slight pulsation of the hose will always be noticeable near the pump. Excessive pulsation of the hose near the pump is normally due to higher than average line pressures caused by stiff, harsh mixes, or extremely long pumping distances.

The use of 2 - 1/2" I.D. hose in these extreme cases reduces line pressures or the addition of slight amounts of water to the mix, if permissible, will permit easier pumping. The use of certain pumping admixtures may help.

If excessive pulsation exists in the hose, it is advisable to use burlap or some means of wear protection under the hose at points where the hose may wear through the outer cover; e.g. overforms, steel or sharp curbs.

Cam Roller

If the cam roller does not ride on the cam profile smoothly, it may be caused by insufficient line back-pressure; e.g., a wet mix with only 50 feet of hose. Add more hose as necessary. It can also be caused by cavitation or the passing of over-sized aggregates through the valving, causing it to skip.

Snap-Joint

When using Snap-Joint couplings with gaskets to join hose, see that they are washed clean after each job. Keeping the hose ends clean (heavy duty) is very important for the best job setup. A thin coat of grease on the rubber gasket or dipping both coupling and gasket in water before coupling the hose will make for easier installation.

C-30HDN PUMP — TOWING GUIDELINES

Towing Safety Precautions

CAUTION - Local Towing Regulations

Check with your county or state safety towing regulations department before towing your **concrete pump**.

To reduce the possibility of an accident while transporting the pump on public roads, always make sure that the trailer and the towing vehicle are in good operating condition and both units are mechanically sound.

The following list of suggestions should be used when towing the pump:

- Make sure that the hitch and coupling of the towing vehicle are rated equal to, or greater than the trailer "gross vehicle weight rating" (GVWR).
- **ALWAYS** inspect the hitch and coupling for wear. **NEVER** tow the light tower's trailer with defective hitches, couplings, chains etc.
- **CHECK** the tire air pressure on both the towing vehicle and the trailer. Also check the tire tread wear on both vehicles.
- **ALWAYS** make sure the trailer section of the pump is equipped with a "Safety Chain".
- **ALWAYS** attach trailer's safety chain to frame of towing vehicle.
- **ALWAYS** make sure that the vehicle and trailer directional, backup, brake, and trailer lights are connected properly and are working properly.
- Remember in most cases the maximum speed unless otherwise posted for highway towing is 45 MPH, however before towing your pump, check your local state, and county vehicle towing requirements. Recommended off-road towing is not to exceed **10 MPH** or less depending on type of terrain.
- Place *chocked blocks* underneath wheel to prevent **rolling**, while parked.
- Depending on soil conditions and location it may be necessary to place *support blocks* underneath the trailer's bumper to prevent **tipping**, while parked.
- Inflate tires to correct pressure, inspect tires for cuts, and excessive wear. See Table 3 (Tire Wear Troubleshooting).

- Check wheel mounting lug nuts with a **torque wrench**. Torque wheel lug nuts as described in the "**Lug Nut Torque Requirements**", Table 5.
- Make sure brakes are synchronized and functioning properly.
- Check tightness of suspension hardware (nuts and bolts).
- Avoid sudden stops and starts. This can cause skidding, or jackknifing. Smooth, gradual starts and stops will improve gas mileage.
- Avoid sharp turns to prevent rolling.
- Retract wheel stand when transporting.
- **DO NOT** transport pump with fuel in the fuel tank.

CAUTION - NEVER Use Defective Couplers

If the trailer coupler is deformed replace entire coupler. **NEVER** tow the pump with a defective trailer coupler. There exist the possibility of the trailer separating from the towing vehicle.

Pump Trailer Vehicle Connection

1. Check the vehicle hitch ball, and trailer coupler for signs of wear or damage. Replace any parts that are worn or damaged before towing.
2. Use only the 2-inch ball diameter with a towing capability of 5,000 lbs. (2,268 kg) as indicated on the trailer's coupler. Use of any other ball diameter will create an extremely dangerous condition which can result in separation of the coupler and ball or ball failure.
3. Be sure the coupler is secured to the hitch ball and the lock lever is down (locked).
4. Attach safety chains as shown in Figure 2. Remember to **cross** the safety chains.
5. After towing for about 50 miles recheck the entire towing system for tightness.

Recommended Maintenance

1. Smear ball socket and clamp face with chassis grease. Periodically oil pivot points and wear surfaces of coupler with SAE 30 W motor oil.
2. When parking or storing the concrete pump, keep the coupler off the ground so dirt and other debris will not build up in the ball socket.

C-30HDN PUMP — TOWING GUIDELINES

Figure 24 shown below illustrates the typical towing application that should be used when towing the pump.

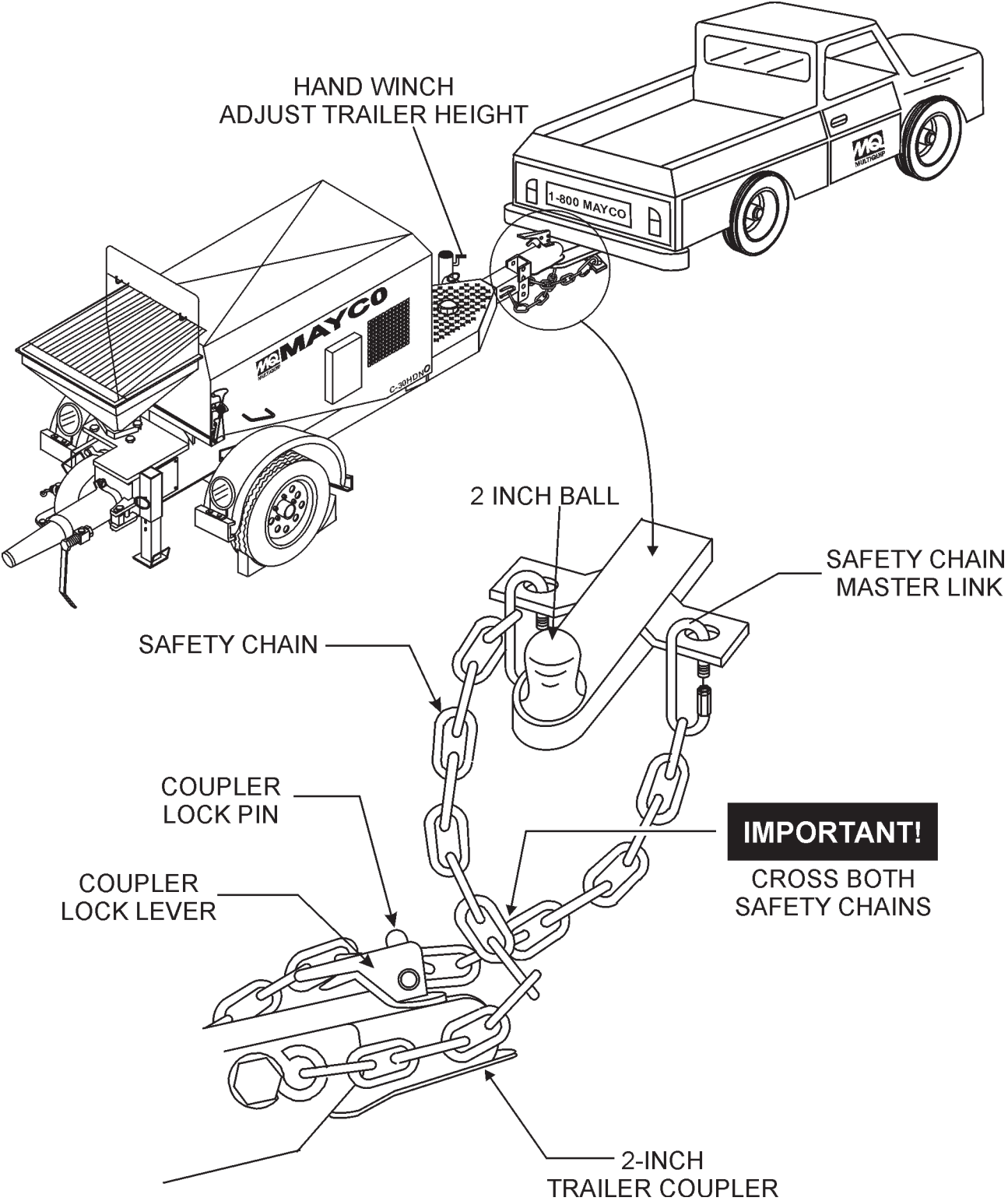

Figure 24. Towing Applications

C-30HDN PUMP — TRAILER SAFETY GUIDELINES

Trailer Safety Precautions



CAUTION - General Trailer Safety

ALWAYS make sure that the trailer is in good operating condition. Check the tires for proper inflation and wear. Also check the wheel lug nuts for proper tightness.

This section is intended to provide the user with trailer service and maintenance information. Remember periodic inspection of the trailer will ensure safe towing of the equipment and will prevent damage to the equipment and personal injury.

It is the purpose of this section to cover the major maintenance components of the trailer. The following trailer components will be discussed in this section:

- Tires
- Lug Nut Torquing
- Suspension
- Electrical

The following list defines the major trailer components:

1. **Fuel Cell** – Provides an adequate amount of fuel for the equipment in use. Fuel cells must be empty when transporting equipment.
2. **Frame Length** – This measurement is from the ball hitch to the rear bumper (reflector).
3. **Frame Width** – This measurement is from fender to fender.
4. **Jack Stand** – Trailer support device with maximum pound requirement from the tongue of the trailer.
5. **Coupler** – Type of hitch used on the trailer for towing. This unit employs a 2 in. ball.
6. **Tires Size** – Indicates the diameter of the tire in inches (10, 12, 13, 14, etc.), and the width in millimeters (175, 185, 205 etc.). The tire diameter must match the diameter of the tire rim. This unit employs 7.35 x 14 in. tires.
7. **Tires Ply** – The tire ply (layers) number is rated in letters: 2-ply, 4-ply, 6-ply, 8-ply, 10-ply etc. This unit employs 4-ply tires.
8. **Wheel Hub** – The wheel hub is connected to the trailer's axle.
9. **Tire Rim** – Tires are mounted on a tire rim. The tire rim must match the size of the tire.
10. **Lug Nuts** – Used to secure the wheel to the wheel hub. Always use a torque wrench to tighten down the lug nuts. See Table 5 and Figure 4 for lug nut tightening and sequence. This unit employs 5 lug nuts to secure the wheel to the hub.
11. **Axle** – This trailer employs a torsion bar type suspension, which can support 3,500 lbs.
12. **Electrical** – Electrical connectors (looms) are provided with the trailer so that brake lights and turn signal lights can be connected to the towing vehicle. See Figure 36 for proper wiring connections.

C-30HDN PUMP — TRAILER SAFETY GUIDELINES

Tires/Wheels/Lug Nuts

Tires and wheels are a very important and critical components of the trailer. When specifying or replacing the trailer wheels it is important the wheels, tires, and axle are properly matched.

⚠ CAUTION - General Trailer Safety

DO NOT attempt to repair or modify a wheel. **DO NOT** install an inter-tube to correct a leak through the rim. If the rim is cracked, the air pressure in the inter-tube may cause pieces of the rim to explode (break-off) with great force and can cause serious eye or bodily injury.

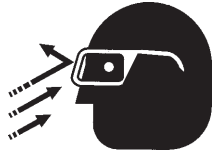





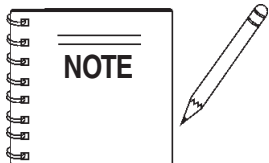

Tires Wear/Inflation

Tire inflation pressure is the most important factor in tire life. Pressure should be checked cold before operation. **DO NOT** bleed air from tires when they are hot. Check inflation pressure weekly during use to insure the maximum tire life and tread wear.

Table 3 (Tire Wear Troubleshooting) will help pinpoint the causes and solutions of tire wear problems.



ALWAYS wear safety glasses when removing or installing force fitted parts. Failure to comply may result in serious injury.

WEAR PATTERN		CAUSE	SOLUTION
	Center Wear	Over Inflation	Adjust pressure to particular load per tire manufacturer.
	Edge Wear	Under Inflation	Adjust pressure to particular load per tire manufacturer.
	Side Wear	Loss of chamber or overloading.	Make sure load does not exceed axle rating. Align wheels.
	Toe Wear	Incorrect toe-in	Align wheels.
	Cupping	Out-of balance	Check bearing adjustment and balance tires.
	Flat Spots	Wheel lockup & tire skidding.	Avoid sudden stops when possible and adjust brakes.

Torsion Bar Suspension

The torsion bar suspension and associated hardware (Figure 3) should be visually inspected every 6,000 miles for signs of excessive wear, elongation of bolt holes, and loosening of fasteners. Replace all damaged parts (suspension) immediately.

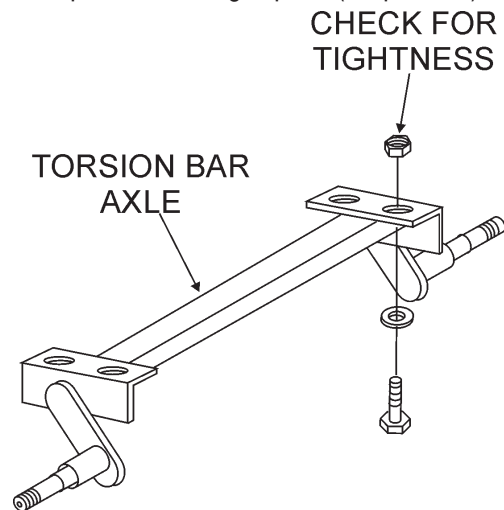

Figure 3. Major Suspension Components

C-30HDN PUMP — TRAILER SAFETY GUIDELINES

Lug Nut Torque Requirements

It is extremely important to apply and maintain proper wheel mounting torque on the trailer. Be sure to use only the fasteners matched to the cone angle of the wheel. Proper procedure for attachment of the wheels is as follows:

1. Start all wheel lug nuts by hand.
2. Torque all lug nuts in sequence (Figure 4). **DO NOT** torque the wheel lug nuts all the way down. Tighten each lug nut in 3 separate passes as defined by Table 4.
3. After first road use, retorque all lug nuts in sequence. Check all wheel lug nuts periodically.

Table 5. Tire Torque Requirements

Wheel Size	First Pass FT-LBS	Second Pass FT-LBS	Third Pass FT-LBS
12"	20-25	35-40	50-65
13"	20-25	35-40	50-65
14"	20-25	50-60	90-120
15"	20-25	50-60	90-120
16"	20-25	50-60	90-120

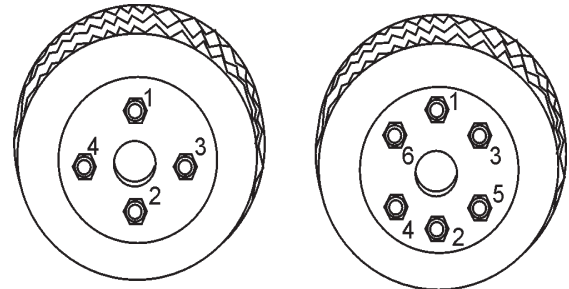

4-LUG NUTS

6-LUG NUTS

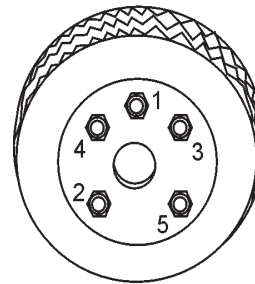

5-LUG NUTS

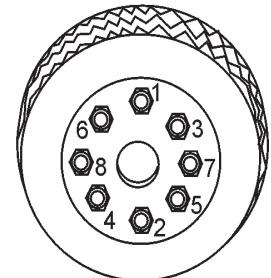

8-LUG NUTS

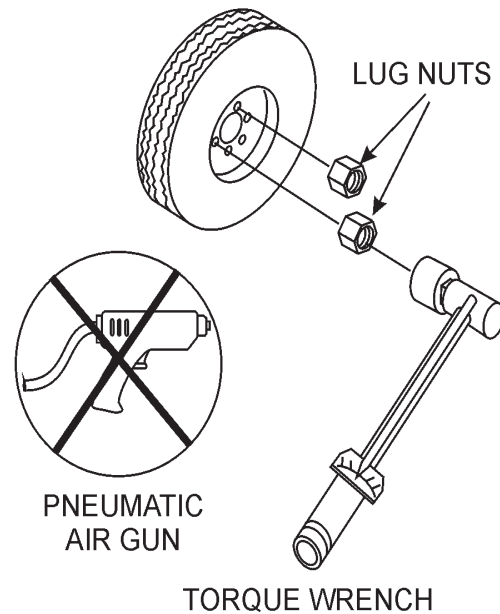
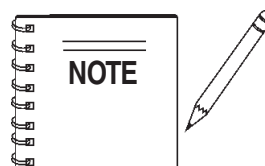

Figure 26. Wheel Lug Nuts Tightening Sequence



NEVER! use an pneumatic air gun to tighten wheel lug nuts.

C-30HDN PUMP — MAINTENANCE (PUMP)

Preventive Maintenance

It is extremely important to maintain this pump due to the highly abrasive nature of concrete material.

1. Inspect all drive components for loose or worn bolts.
2. Drive belt/chain should be checked to remove all slack. Refer to adjustment procedure.
3. **ALWAYS** carry extra “O” rings.
4. Keep entire pump clean of concrete to prevent build-up.
5. **ALWAYS** grease every fitting daily. Use only premium grade grease.

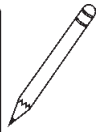
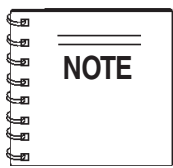

Over greasing will not damage pump.

General Clean-up Procedure

1. Ensure that there is no blockage in the hose and line (Pumping Tips, step 8) or in the manifold (Pumping Tips, step 7). If a blockage exists, clear it to ensure proper operation the next time it is used. At the end of every pour, or during long delays during a pour, the pump and delivery system must be thoroughly cleaned by removing all concrete material.
2. Proper wash out of all materials or build up within the pump manifold and hoses following the pumping operation will prevent problems when starting the next job. After completion of the pour, pump the remaining concrete in the hopper through the discharge line.

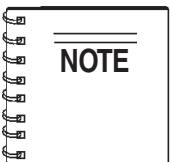

To avoid the possibility of separation during clean-up, do not pump the concrete below the inlet ball in the hopper. It is best to leave approximately 3 to 4 inches of concrete above the inlet ball.

3. Turn the pump engine off before filling the hopper with water. Engine vibration at idle may “separate” material in the hopper, causing jamming in manifold when pumping is resumed.
4. Fill hopper with water and resume pumping. The water will push the concrete through the line. When the water runs clear at the end of the hose, disconnect lines and shake out all the sand and sediment so the lines will be clean for the next pour.
5. It is important that the hinged discharge cone on the pump manifold be opened and all remaining concrete (rock and sand) be thoroughly washed out. This must be done after each job to prevent concrete build up in the discharge manifolds and 3” discharge elbow.

Piston Cup Wear

The **rubber piston cups** are a natural wear component and **will require** periodic replacement. The life of the rubber cups depends on many factors, proper oil level, oil cleanliness, abrasiveness of aggregate being pumped and material slump etc.

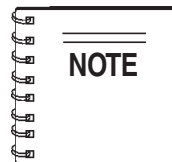

IMPORTANT! To ensure maximum cup life, the oil level in the lubrication box **must be** maintained at the proper level. In addition the lubrication box must be cleaned periodically.

As the rubber piston cups wear, fine cement particles will accumulate in the bottom of the lubrication box. Once this cement paste reaches 1-inch in height, it is recommended that the lubrication box be drained (flushed) and cleaned and the oil replaced with new SAE 30 motor oil.

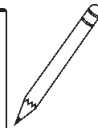
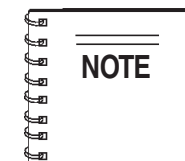

There are two clean-out ports located at the bottom of the lubrication box.

Any questions regarding the lubrication box clean-out procedure, contact the MAYCO Service Department.

C-30HDN PUMP — MAINTENANCE (PUMP)

Lubrication Box

The C-30HDN model features a fully enclosed **lubrication box**, which utilizes the "**SPLASH**" method of lubrication.

Visually inspect the oil in the lubrication box (Figure 16) by making sure the oil is at the correct operating level as indicated by the dip stick. Also reference the oil level decal (Figure 17) adjacent to the lubrication box.

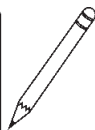
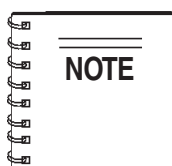

Make sure the pump is on a secure level surface when checking the oil level inside the lubrication box.

! CAUTION - Checking Lubrication Oil Levels

The oil level **must** be **checked daily** to ensure adequate oil level and oil cleanliness.

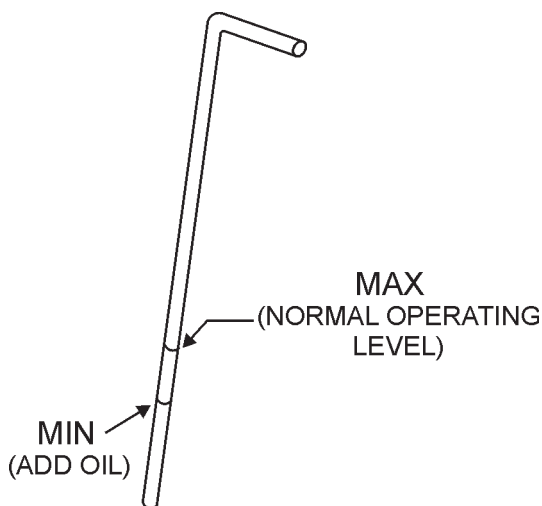

Figure 27. Lubrication Box Dipstick

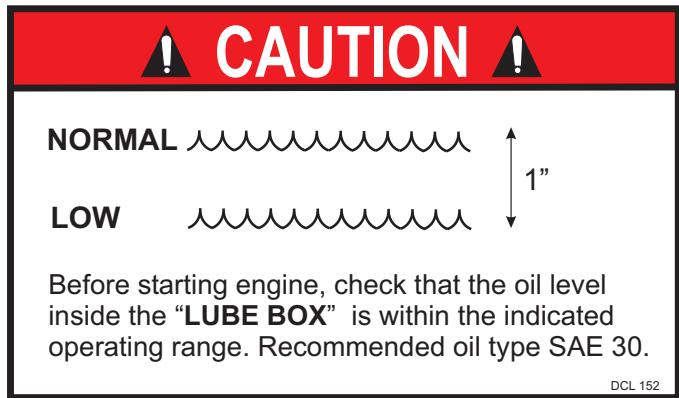

Figure 28. Lubrication Box Oil Caution Decal

Sponge Clean-out Procedure

This section will explain the recommended procedure for using a **sponge** to clean out the **hose lines**.

! CAUTION - Clearing The Pump

NEVER use **muratic acid** to clear the pump. Acid will dissolve the chrome finish on the pumping cylinder.

NEVER use compressed air to clean out the lines.

When using a clean-out hook to clean out the rear of the redi-mix truck, use a **safety chain** to secure the clean-out hook to some solid part of the redi-mix truck to prevent the hook from jumping off the redi-mix truck's hopper. Run the pump at half throttle.

1. After completion of the pour, pump the remaining concrete in the hopper through the discharge line. Using a shovel, clean the sides of the hopper.

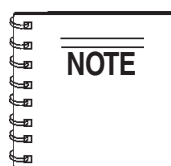

The pump engine should be turned **OFF**, as explained in General Clean Up Procedure.

After the sides of the hopper have been cleaned, add a small amount of water to the remaining concrete in the hopper and hand mix.

2. Start the pump engine and pump the hopper all the way down.
3. Disconnect the hose from the pump. Fill the hopper with water and pump the remaining concrete out of the pump.
4. Open the hinged discharge cone and thoroughly wash out all remaining concrete (sand-sediment) from the cone and pump manifolds. Close the discharge cone and lock in place.
5. Take a sponge (2"x 4"x 6") and soak it with water. Take the hose that is disconnected from the pump and shake out the concrete so that about 2 feet of it is clear. Insert the sponge into the hose.
6. Reconnect the hose to the pump. Fill the hopper with water and resume pumping. Run the pump approximately half throttle. The sponge will be discharged at the end of the line followed by clear water. At this point, the pump and lines will be completely clean and ready for the next job.

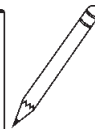
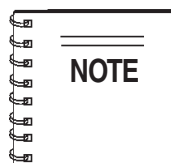

Repeat steps 1 through 6 a few times to ensure that the hose lines are thoroughly cleaned.

C-30HDN PUMP — MAINTENANCE (PUMP)

Crankshaft and Cam Assembly Procedure

1. Set bearing block (P/N EM14303) into hydraulic press. Place bearing cup into bearing block and press in evenly. Bearing cup should be aligned equally on both sides of bearing block.
2. Set **crankshaft** into hydraulic press with the long end towards the top. Install spacer (P/N EM14322), O-ring (P/N EM14326) and bearing cone (P/N EM14325) onto crankshaft. Place bearing block on crankshaft until the bearing cone is riding in the bearing cup.
3. Insert bearing cone spacer (P/N EM14323) onto crankshaft and inside bearing block. Install second bearing cone until it is seated inside bearing cup.
4. Place O-ring and spacer (P/N EM14302) on crankshaft. Set cam weldment on top of spacer. Install crankshaft key and cam key on cam bushing (P/N EM14301).
5. Slide cam bushing down crankshaft and align the bushing, cam and crankshaft. Install sleeve over crankshaft and align with hydraulic press. Install cam bushing bolts loosely. Press bushing down onto bearing assembly. Leaving pressure on the bushing, tighten cam bolts evenly to 40-50 foot pounds.
6. Release pressure on the bushing, reapply pressure to bushing and tighten bolts evenly to 40-50 foot pounds. Repeat procedure 3 to 4 times.
7. After bushing has been fitted tightly into cam, remove from hydraulic press. Remove one bolt at a time, using Loctite, install bolts and torque to 65-70 foot pounds. Counter sink set screw hole and install dog point set screw and second set screw both with Loctite™.
8. Place cam bearing onto crankshaft keeping bearing loose.

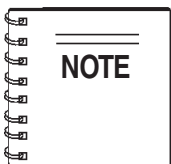

Make sure the eccentric lock is facing toward the outside of the pumping unit.

9. Set crankshaft assembly into the pump box and align both bearing assemblies with the pump box mountings.
10. After crankshaft assembly is securely fastened to the pump box, place sprocket (P/N EM14307) onto the cam side of the crankshaft assembly. Install bushing (P/N EM14309) into sprocket. Align sprocket with sprocket on countershafts and tighten bolts.
11. Install chain P/N EM14308. To adjust, loosen locknuts on pusher bolts and tighten chain to approximately 1/2 in. slack in the chain. Once chain is adjusted properly, tighten down locknuts.

Ball and Seat Replacement Procedure

1. Remove 3"x2" reducer and 3" elbow from the pump outlet. Remove exhaust gate and Y-manifold (secondary manifold). Check ball seat and ball stop pin for wear. If any wear is detected, the part should be replaced. Remove T-manifold (primary manifold). Check all parts for wear. Remove hopper and hopper seat and inspect.
2. Loosen the piston nuts and remove the piston cup assembly and cylinders. Inspect all parts for wear and replace parts with excessive wear. Check oiler pump for proper operation.
3. Clean all parts thoroughly, removing all foreign material and concrete slurry. Once parts are clean, install concrete cylinders. Place oiler plate O-ring in place and coat with oil. Install small O-ring on piston rod. Run oiler line through the cylinders and connect in the oiler fitting on the oiler plate.
4. Push oiler plate into cylinder. Install ring and felt holder, soak felt ring in oil, then install around felt holder in cylinder. Make sure the bronze ring is flat, then push it up flush with the ring and felt holder.
5. Coat piston cup with oil and push it into the cylinder. Install bushing into center of piston cup. Put small O-ring on rod, place face plate on rod and tighten down securely. Repeat these procedure on the opposite cylinder.
6. Thoroughly check T-manifold, ball stoppings and both steel balls for wear. Insert an O-ring in the top flange and in the leading edge of the manifold. Put the manifold onto the primary side of the pump and install bolts leaving them loose.
7. Check Y-manifold for wear, install all O-rings, ball stop pin, ball and seat. Align and install Y-manifold to T-manifold and cylinder assembly. Tighten Y-manifold bolts first before tightening T-manifold bolts. After manifolds are tight, check O-rings for slippage.
8. Insert seat into frame hole directly above the T-manifold. The seat orifice should fit inside the frame itself, then the seat sits on top of the orifice. On the dura-seat, set the big end of the seat in the frame. The seat, or the small part of the dura-seat, fits into the bottom of the hopper.
9. After tightening the manifold bolts and inserting the seats in place, set the hopper over the seat and align the bolt holes. Tighten bolts, check O-ring and seat for alignment.
10. Check exhaust gate for wear, install and align gate onto Y-manifold. Insert O-ring into exhaust gate flange and close gate. Lock down lever and adjust clamp arm.
11. Install 3 in. elbow and 3x2 in. reducer. Fill hopper half full and check for leaks.

Clutch Lining Replacement (For P/N EM14320 Clutch Assembly Only)

The normal lining thickness measures 3/16 of an inch. If the clutch starts to slip or make an usual noise, it may be necessary to replace the lining. Please note that the lining retaining rivets **should not be exposed** to the rotating weight.

The following procedure will assist you in replacing the lining.

1. Remove worn out lining and rivets. Check clutch springs and flyweights for wear.
2. Cut 1/8 in. off of each end of clutch lining. Slide lining into place. Insert one rivet into clutch lining hole. (Make sure rivet goes from inside out.) Wedge a flathead screwdriver between clutch flyweight and rivet head.
3. Adjust screwdriver so that the rivet sticks out from the clutch housing approximately 1/8 of an inch. With a flat punch, pen the ends on the rivet so that it locks in place with the clutch housing. Repeat this procedure for all remaining clutch rivets.

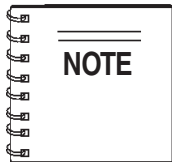

The clutch lining is a normal maintenance item and will require periodic replacement.

C-30HDN PUMP — MAINTENANCE (PUMP)

Bearing Installation

1. Install the bearing components on the crankshaft making full contact with the back side of the crank disc as indicated the symbol #. See Figure 25 below.
2. Install the bushing in the cam weldment and slide it onto the crankshaft until contact is made with the bearing spacer.
3. Tighten the 3 **allen head bolts "A"** while exerting pressure on the bushing towards the bearing spacer.

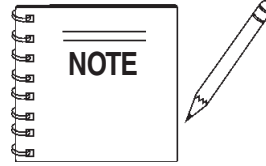

It is important that the **Bearing Assembly** is installed properly.

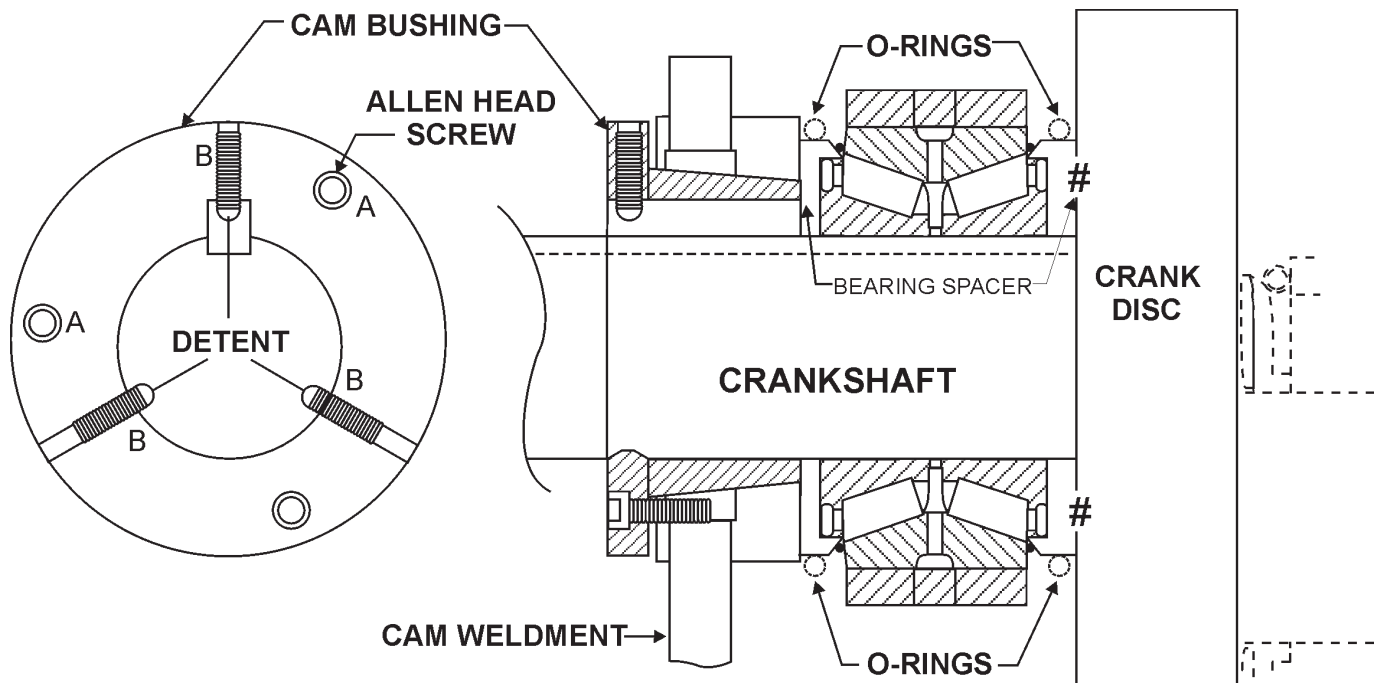
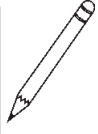
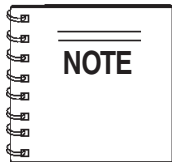

Figure 29. Bearing/Cam Bushing Installation

C-30HDN PUMP — MAINTENANCE (PUMP)

Detent Hole (3) Installation

1. After the bearing assembly has been installed, remove the three “dog type” allen head set screws (B) to allow detents to be drilled. See Figure 26 below.



The detent holes will prevent the bushing from sliding away from the bearing spacer when the pump is under load.

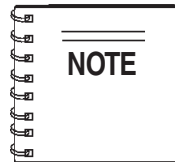

Position the ‘O’ ring on the O.D. of the bearing spacer during assembly to assure proper bearing adjustment.

2. Use a 9/32” drill to “detent” half (minimum 1/8” deep). Then “chase” the threads with a 3/8-16 bottom tap and blow out the chips after drilling, to be certain that the “dog type” allen set screws bottom in the detents to prevent the taper bushing from sliding laterally.

4. Drill (detent) the shaft under the allen set screws “B” to prevent the bushing from the sliding away from the bearing spacer when the pump is under a load.

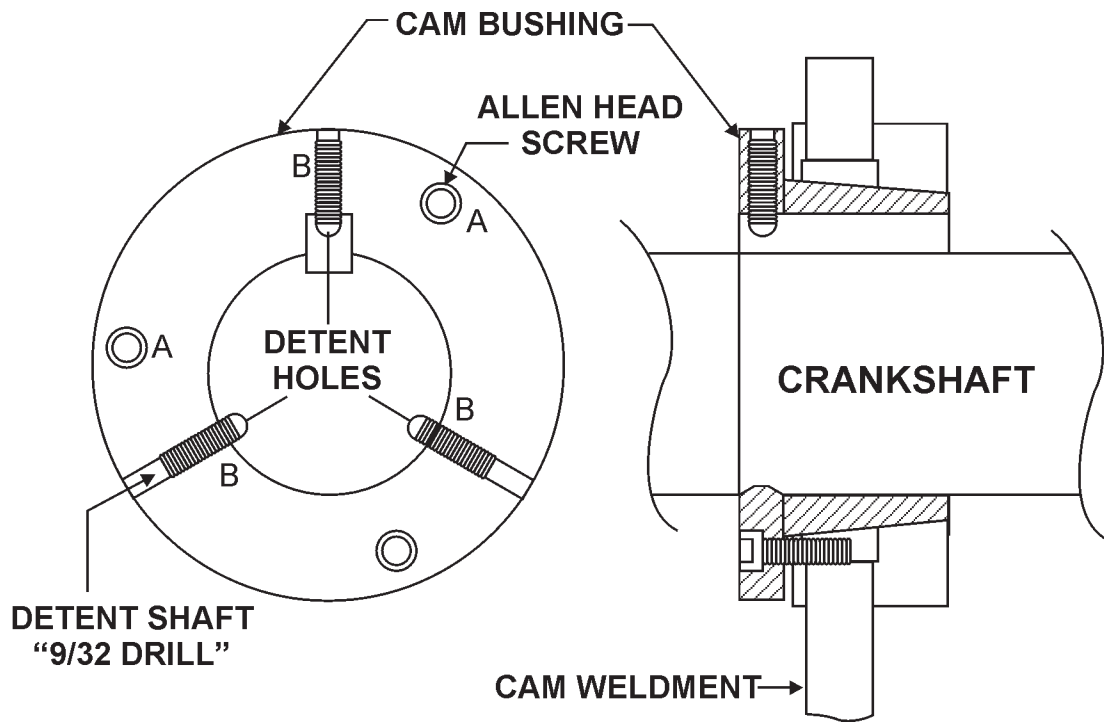

Figure 30. Detent Holes

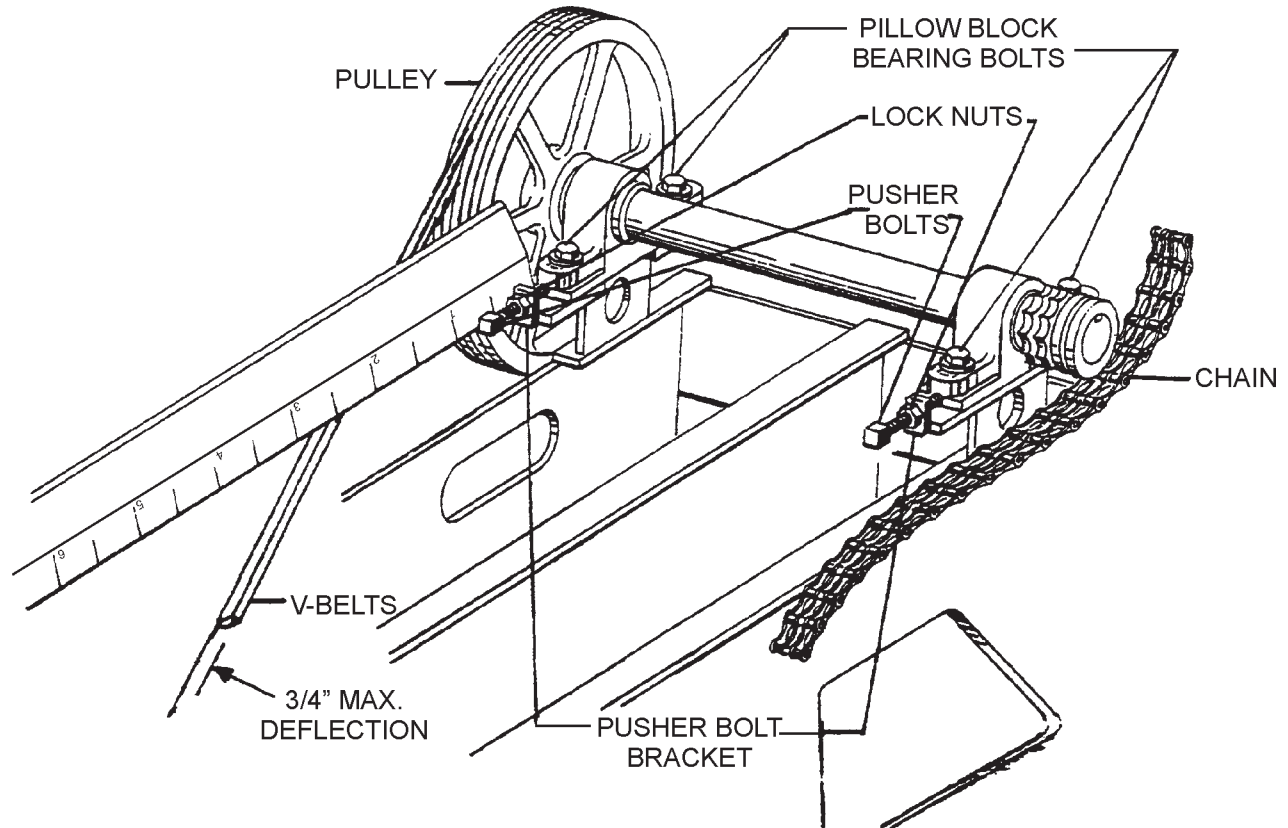
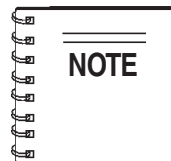

Figure 31. V-Belt and Drive Chain Adjustment

V-Belt And Drive Chain Adjustment

1. Loosen the pillow bearing bolts (Figure 27) only to the point where the bolts will remain snug.
2. Unlock the two pusher bolt lock nuts.
3. Turn each pusher bolt clockwise an equal amount until the chain is to proper adjustment of approximately 3/8 to 1/2 in. slack in the chain. It is very important that the pulley side and the chain side (pillow block bearings) are within 1/16" of an equal distance.
4. This distance can be checked by using a tape measure or a straight edge ruler, measuring from the inside of the pusher bolt bracket to the face of the pillow block bearing.
5. The drive chain should be adjusted regularly to remove all slack. Once all slack is removed, **DO NOT** over-adjust, as this will overload the shaft bearings. A slack chain on the crank drive creates backlash and shock loads on the shafts and bearings which results in shorter wear/life of the drive components.
6. Lubricate the chain regularly. Note-it is advisable to carry a spare chain and master links for replacement in the field if necessary.
7. Drive belts should be regularly adjusted to prevent slippage. To adjust the belts, loosen the engine mounting bolts and move the engine until there is a maximum 3/4 in. deflection in the belts, retighten the engine mounting bolts.
8. Frequent inspections should be made on all drive components to make certain that all bolts and nuts remain tight.



Prior to adjusting the chain, place the lobe of the cam in the down position. The chain should have 83 rivets, Including one each, half-link and full link.

Roller Chain Application

A properly selected, installed and maintained **drive chain** (Figure 28) is an extremely versatile means of power transmission. It is possible, however, to greatly reduce a chain's life and even induce failure if the chain is abused through improper installation, operating or maintenance procedures. In certain applications, failure can lead to personal injury or property damage.

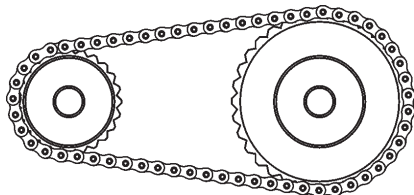

Figure 28. Drive Chain

Recommendations and comments on how to get the most from your roller chain drive are given in this section. The drive chain used in the MAYCO C-30HDN pump is manufactured by the "DIAMOND CHAIN COMPANY™"

Working Loads

UTS-Ultimate Tensile Strength-is the one time pull required to break the chain. For single strand chain, the load (pull) applied to the chain in service should never exceed 1/6th of the UTS for the chain being used except as noted below.

It is possible to exceed the allowable working loads for a limited number of cycles, but you should contact Diamond Chain Company before this is considered. **A roller chain should never be loaded above 50% of UTS for even one cycle. To do so will damage the chain structure and reduce its capacity.**

The UTS or one time breaking load of multiple strand chain is the UTS of a single strand chain times the number of strands; i.e., two strand chain is twice as strong as single.

When allowable working loads are considered, however, the capacity of each strand in a multiple strand chain is only 65% of the single strand rating; thus, three-strand chain would rate not three times single but only 1.95 times. This is because the chain load cannot be exactly distributed across all three strands of the three-strand chain.

Installation and Drive Alignment

Chain and sprockets (Figure 29) must be installed correctly. Sprockets must be properly aligned and sprocket shafts must be parallel so the drive will run in a plane perpendicular to them. Axial alignment should be checked with a straight edge which will extend across the finished sides of the sprockets. They should be true-running with minimum wobble and eccentricity. The higher the drive speed, the more important these details become.

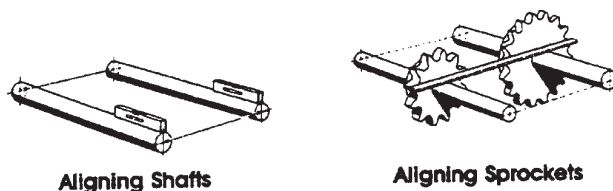

Figure 29. Shaft and Drive Sprocket Alignment

The chain should be installed so the slack span is properly tensioned. To check chain tension (Figure 30), turn one sprocket to tighten the upper span of the chain while holding the other sprocket fixed. The lack span should have 4-6% of span length in the mid-span movement for horizontal drives and 2-3% for vertical drives.

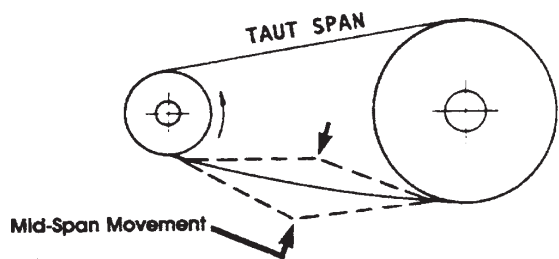

Figure 30. Drive Chain Tension

A roller chain's capacity can be significantly reduced if it is twisted or bent sideways in the direction of the pin axis. Exercise particular care in alignment of hoist or other applications where loads are suspended near personnel.

Drive Chain Lubrication

As a chain articulates in entering and leaving a sprocket, there is relative movement between pin and bushing surfaces. These surfaces wear causing chain elongation. If a lubricant film can be maintained between the pin and bushing, the wear rate is very slow and the chain wear life very long. Maintaining the oil film is relatively simple at low speeds but becomes increasingly difficult as the speed increases.

It is recognized that good lubrication is not possible in many applications, so shorter wear life must be accepted in these situations.

In general, chain wear leads to rough or unsatisfactory service prior to actual chain breakage. Good lubrication can help to prevent chain failure by providing protection against rust or corrosion. Rusting can allow pits to form in the surfaces of the chain parts causing stress concentration points. This can lead to chain failure at relatively low loads.

The clearance between pin and bushings is very small (Figure 31), on the order of .003 to .005 inches. A lubricant must be thin enough to flow into the chain. SAE 30 weight oil is about right for room temperature. Lighter oil should be used for lower ambients and heavier for higher operating temperatures. Grease should not be used as it cannot penetrate chain clearances.

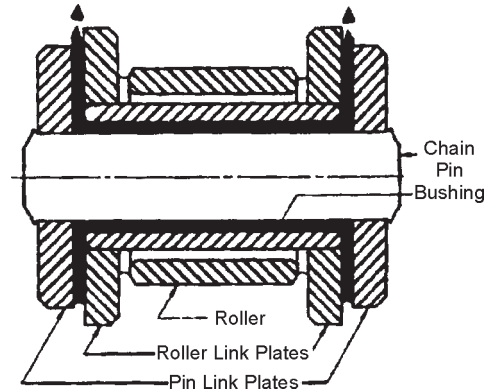

Figure 31. Chain-Link Cross Section

C-30HDN PUMP — MAINTENANCE (PUMP)

Assembling and Disassembling Drive Chain

CAUTION - Drive Chain Safety

You may be seriously injured if you attempt to install the drive chain while the pump is running. **TURN-OFF** the engine and lock out gears and sprockets before attempting installation.

Once installed, the drive chain must be guarded to prevent personal injury or property damage in the event the chain separates during operation. **NEVER** run pump with drive chain guard removed.

CAUTION - Eyesight Hazard

The components of the drive chain are hardened parts. Striking these parts may cause metal chips to break off from the chain or the tools used resulting in personal injury.

During all stages of chain disassembly and assembly, wear **safety glasses** to prevent metal parts or chips from entering your eyes and have personnel in the immediate area do likewise.

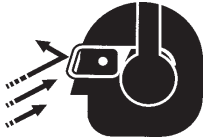

Chain-Link Pin Removal

1. If chain is of cotter pin-type construction, remove cotters.
2. If chain is riveted type construction, grind pin heads off so pin ends are flush with the linkplate.
3. Drive pins out of linkplate using a Diamond pin extractor Model P/N 113 or 135. Some multiple strand chains or large pitch models will require a hammer and punch or a press to remove the pins.

Installation Of Coversides

Diamond Chain coversides are manufactured three different ways:

- Slip Fit
- Modified Press Fit
- Full Press Fit

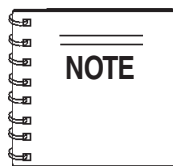

Modified and **Full Press Fits** require some patience and tools to assemble and/or disassemble. Use vice grips, plumbers pliers or a small hammer to drive coversides onto pins.

Installation of Spring Locks and Cotter-Pins

After coversides have been installed, install spring locks or cotters (depending on chain design). Avoid using bent or worn cotters or spring locks. After spring locks (or cotters) are installed, lightly tap pin ends to position these parts snug against the coverside for additional support.

Tips To Remember

- Chain will break if misused or abused
- Serious injury or property damage can result if chain is installed incorrectly.
- Select, install, guard and maintain chain in accordance with equipment manufacturer and "Diamond Chain Company's recommendations.
- Read chain assembly instructions before attempting to install chain on pump sprocket wheel.
- Knowing more about how the chain is constructed may help in assembly and disassembly. Further information may be obtained by calling or writing Diamond Chain Company™.

C-30HDN PUMP — ENGINE RPM ADJUSTMENT

ENGINE RPM ADJUSTMENT

CAUTION - DO NOT Adjust the Engine Governor

The governor is factory adjusted and needs no further adjustment. **DO NOT** adjust governor bolt unless absolutely necessary. Refer to the **Engine RPM Hunting** section.

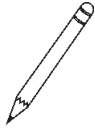
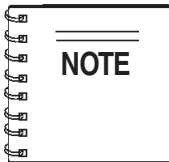

Prior to final adjustment, the engine must be warmed up until the water temperature become 176 degrees F (80 degrees C).

This procedure should be performed without engine load. The hopper should be empty of material or water. The throttle control knob must be pushed into the **IDLE** position.

PROCEDURE

The following procedure references Figure X:

1. Remove the linkage rod from governor arm (ball joint) to carburetor, using **7mm** and **8mm** wrenches and adjust overall rod length to 12.5 inches (31.75 cm.) Once rod length has been correctly adjusted, reconnect to the governor arm.
2. Throttle Cable Travel Adjustment:
 - A. Push the **throttle cable** all the way in. Note the governor spring should have no tension.
 - B. Adjust the idle speed by starting the engine and adjusting the carburetor idle set screw between 850~900 RPM's (use a tachometer to verify engine RPM's).
 - C. Once the idle adjustment has been made, turn the pump control switch to the **ON** position. Using a tachometer observe that the idle speed remains between 850~900 RPM's.

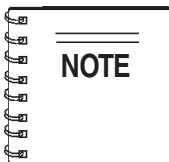

If the clutch engages it will be necessary to adjust the low engine idle RPM. Adjust the lower linkage rod until the engine speed reads 830~900 RPM's.

3. Adjust the RPM Adjustment Bolt:
 - A. With the engine running, turn the **pump control switch** to the **ON** position, slowly pull the **throttle control knob** toward the full throttle position. The engine speed should read between **2,750~2,800** RPM's.
 - B. Leave the throttle setting in this position when adjusting high RPMs and turn the engine **OFF**. The close proximity of moving parts makes this adjustment safer with the engine **OFF**.
 - C. Locate the **High RPM adjustment bolt**. Using a **12 mm** wrench, loosen the jam nut and slowly turn adjustment bolt until it touches the stop on the governor arm. Lock jam nut in place.
 - D. Start the engine and verify using a tachometer that the engine speed now reads between **2,750~2,800** RPM's. If engine RPM's are not within the above range, repeat step 3 until corrected.

The governor and solenoid adjustments are now complete and the linkage will now allow full carburetor throttle shaft movement if ever needed. Under normal conditions these adjustments will not be noticeable, however during conditions of extreme heavy loading an increase in performance can be observed.

ENGINE RPM HUNTING

The term "**hunting**" means sudden fluctuations in engine speed attended by vibration. Be sure to check for engine hunting when maximum engine speed under **no load** has been adjusted.

1. Quickly move the throttle lever to fully open position under **no load** to determine whether engine "hunting" action occurs more than three times.
2. If hunting occurs more than three times, move the governor adjustment bolt 4 mm (0.16 in.) towards the outer end of the sliding groove.
3. Repeat Step 1 until "**hunting**" does not occur more than three times.
4. If specified maximum RPM is changed due to adjustment of governor bolt, adjust the tension of governor spring with governor adjustment not until engine speed reaches specific speed under no load.

C-30HDN PUMP — ENGINE RPM ADJUSTMENT

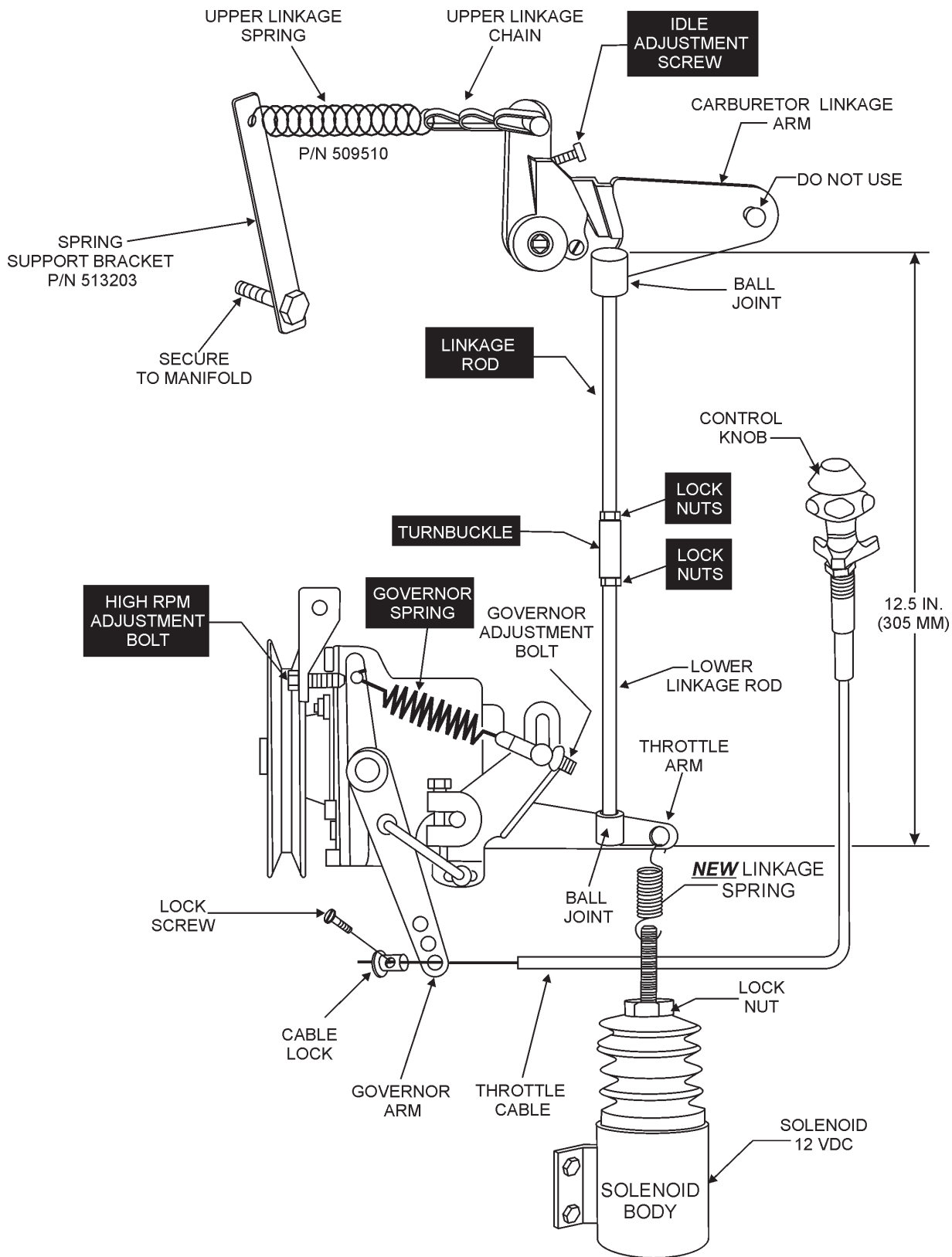

Figure 36. Linkage Adjustment

C-30HDN PUMP — ENGINE TROUBLESHOOTING

Practically all breakdowns can be prevented by proper handling and maintenance inspections, but in the event of a breakdown, please take a remedial action following the diagnosis based on the Engine Troubleshooting (Table 6) information shown below and on the proceeding page. If the problem cannot be remedied, please leave the unit just as it is and consult our company's business office or service plant. For more detail troubleshooting methods, refer to the **NISSAN** Operation and Maintenance manual supplied with your pump.

TABLE 6. ENGINE TROUBLESHOOTING

SYMPTON	POSSIBLE PROBLEM	SOLUTION
Engine will not start or start is delayed, although engine can be turned over.	Speed control lever is in "STOP" position?	Set speed control lever to "START" position.
	Defective fuel pump?	Replace fuel pump.
	Fuel filter clogged?	Replace fuel filter and clean tank.
	Faulty fuel supply line?	Replace or repair fuel line.
	Compression too low?	Check piston, cylinder and valves. Adjust or repair per engine repair manual.
	Oil pressure too low?	Check engine oil pressure.
	Low starting temperature limit exceeded	Comply with cold starting instructions and proper oil viscosity.
	Defective battery?	Charge or replace battery.
At low temperatures engine will not start.	Engine oil too thick?	Refill engine crankcase with correct type of oil for winter environment.
	Defective battery?	Replace battery.
Engine fires but stops soon as starter is switched off.	Throttle lever in STOP position?	Reposition throttle lever to RUN position.
	Fuel filter blocked?	Replace fuel filter.
	Fuel supply blocked?	Check the entire fuel system.
	Electrical problem at fuel solenoid?	Repair using #7 wire.
Engine stops by itself during normal operation.	Fuel tank empty?	Add fuel.
	Fuel filter blocked?	Replace fuel filter.
	Defective fuel pump?	Replace fuel pump.
	Mechanical oil pressure shutdown sensor stops the engine due to low oil?	Add oil. Replace low oil shutdown sensor if necessary.

C-30HDN PUMP — ENGINE TROUBLESHOOTING

TABLE 6. ENGINE TROUBLESHOOTING (CONTINUED)

SYMPTON	POSSIBLE PROBLEM	SOLUTION
Low engine power, output and speed.	Fuel tank empty?	Replace fuel filter.
	Fuel filter clogged?	Replace fuel filter.
	Fuel tank venting is inadequate?	Ensure that tank is adequately vented.
	Leaks at pipe unions?	Check threaded pipe unions tape and tighten unions as required.
	Engine oil level too full?	Correct engine oil level?
Low engine power output and low speed, black exhaust smoke.	Air filter blocked?	Clean or replace air filter.
	Incorrect valve clearances?	Adjust valves per engine specification.
Overheating	Insufficient coolant?	Replenish.
	Loose fan belt?	Adjust fan belt.
	Worn or oiled belt?	Replace belt.
	Inoperative thermostat?	Replace thermostat.
	Worn water pump?	Replace water pump.
	Clogged or leaky radiator?	Flush, repair or replace radiator.
	Faulty radiator filler cap?	Replace radiator cap.
	Air in cooling system?	Retighten each part of cooling system.
	Incorrect engine timing?	Adjust timing.
	Improper governor adjustment?	Adjust governor to the specified conditions.

C-30HDN PUMP — WIRING DIAGRAM

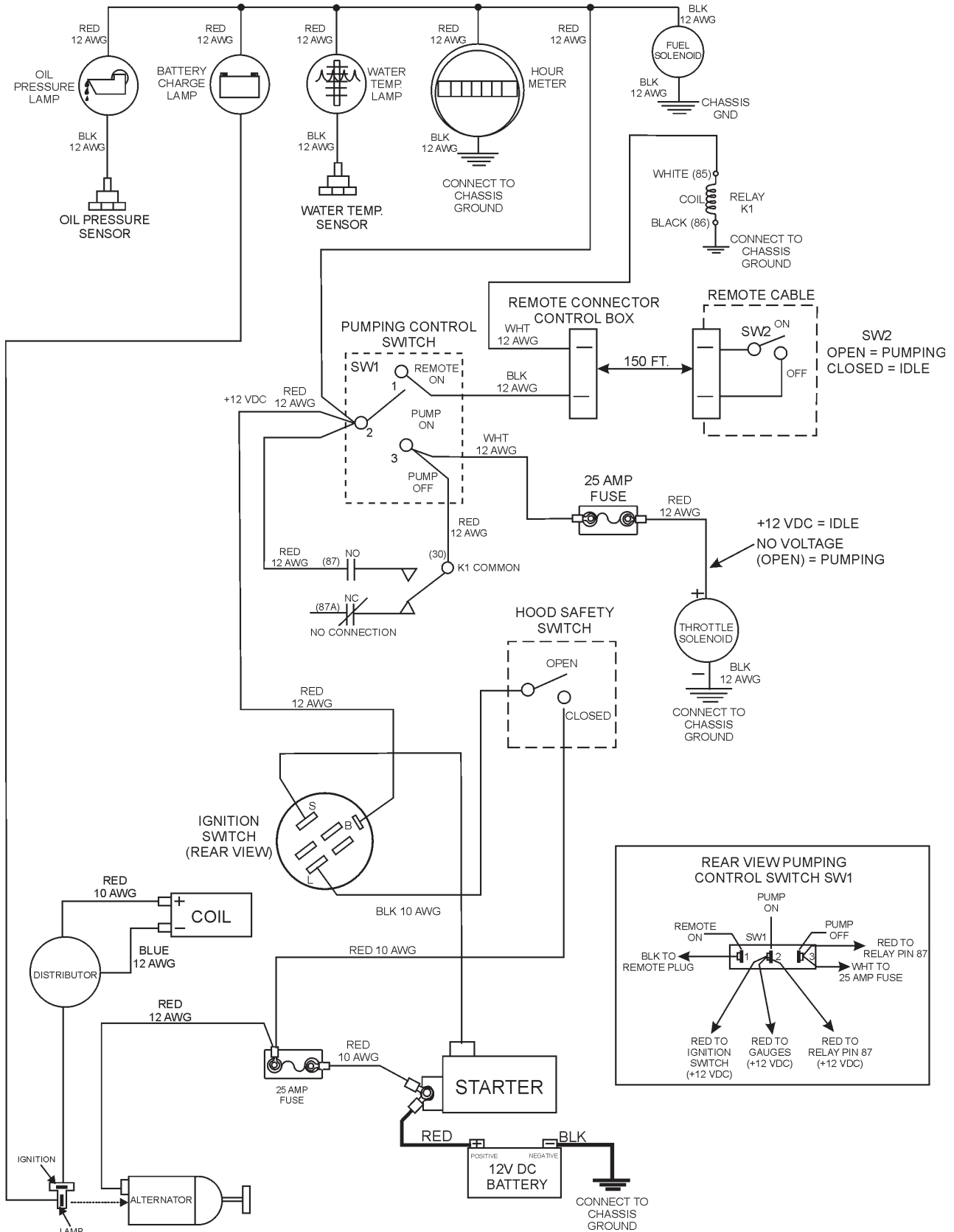

Figure 37. Wiring Diagram

C-30HDN PUMP — WIRING DIAGRAM (TAIL LIGHTS)

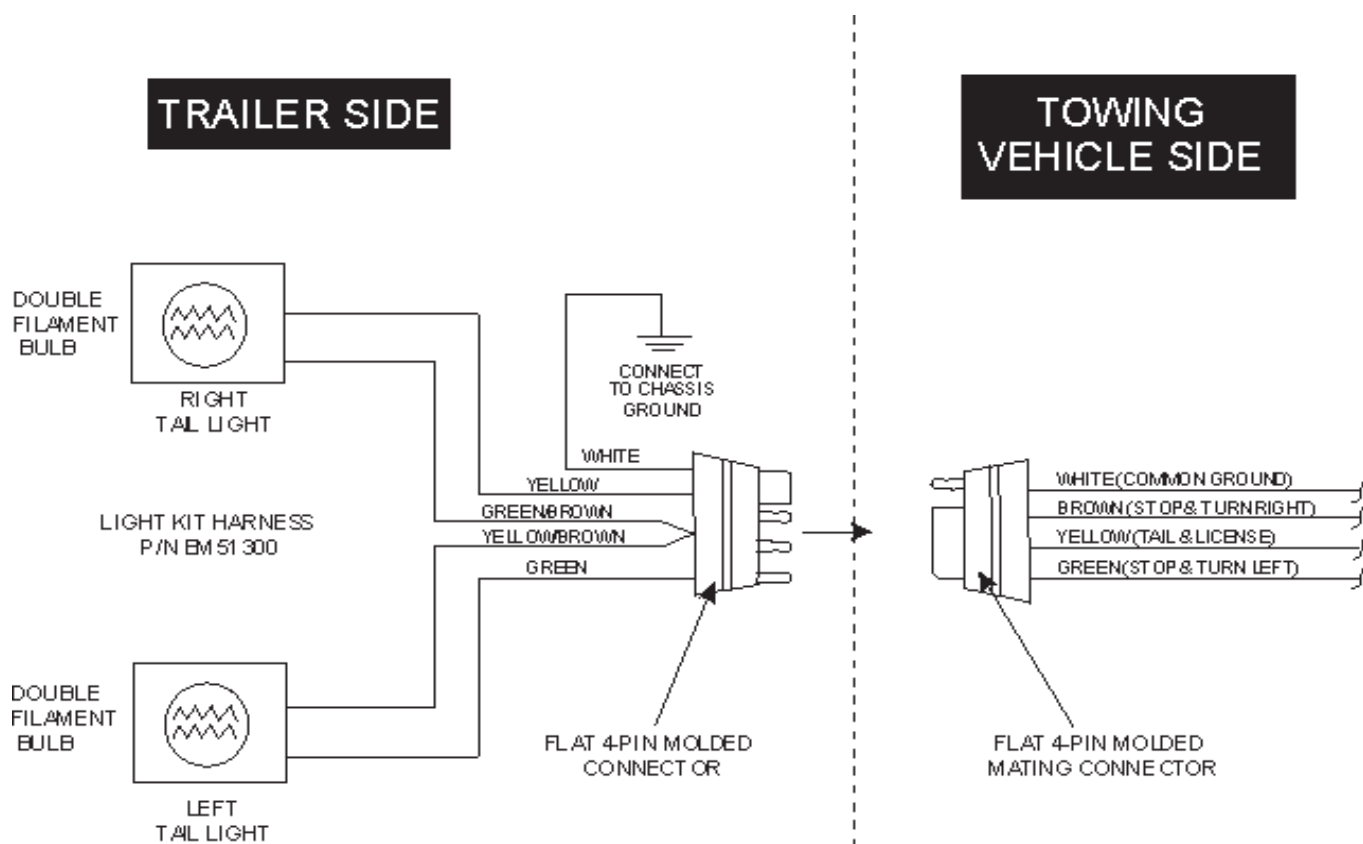

Figure 38. Trailer Tail Lights Wiring Diagram

APPENDIX — C-30HDN CONCRETE MIX INFORMATION

The following information has been extracted from actual testing laboratory reports. The purpose of this printing is only to help create a better understanding of the importance of uniform gradation and proportioning of materials which affect pumpability of concrete mixes. These weights and proportions illustrate that when the sieve analysis is ideal, the sand/rock ratio can be adjusted (65% sand 35% rock) and pumpability should be excellent.

EXAMPLE #1 (A California Test Lab. Report)

JOB: Building Foundations (Water Project)

Sacks per cu./yd. 6.5 designed for 2,500 lbs. in 28 days

Gallons per sack 7.1

Washed Sand-#200 wash 1.3

Organic matter-OK

Specific gravity (SSD) Sand-2.58; Pea Gravel-2.60

Sieve analysis-percent passing

Material	1.5"	1"	3/4"	3/8"	#4	#8	#16	#30	#50	#100	#200
W.C. Sand				100	99.7	79.1	60.4	36.5	14.3	4.0	1.1
Pea Gravel				100	3.0						
% Comb.				100	66	51	39	23	9	3	1.0

DESIGN FOR ONE YARD OF CONCRETE (SATURATED & SURFACE DRY):

Absolute volume of aggregate in one cu. yard: 17.78 cu. ft.













Specific gravity of aggregates in one cu. yard: 2.58

Weight of aggregates in one cu. yard batch: 2850 lbs.

	<u>%</u>	<u>BATCH</u>	<u>SPEC. GRAVITY</u>	<u>ABS. VOL.</u>
W.C. Sand	65	1800	2.58	11.56
PEA GRAVEL	35	1000	2.60	6.22
WATER 46 gal.		1		
CEMENT 6.5 sk.		611		
TOTAL				27.00
ADMIXTURE:		None		
SLUMP		4"		
REMARKS		This mix designed for pumping		
NOTE:		Due to the availability of well-graded sand as shown in the above sieve analysis, this mix pumped very successfully.		

APPENDIX — C-30HDN CONCRETE MIX INFORMATION

A.S.T.M. STANDARD SPECIFICATION FOR GRADING AGGREGATE

SCREEN TYPE	U.S.	METRIC	PERCENTAGE PASSING BY WEIGHT
FINE AGGREGATE: Referred to as washed concrete sand.			
3/8" 	3/8"	9.50 mm	100%
#4 	4,760 microns	4.76 mm	95 to 100%
#8 	2,380 microns	2.38 mm	80 to 100%
#16 	1,190 microns	1.19 mm	50 to 85%
#30 	590 microns	.59 mm	50 to 85 %
#50 	297 microns	297 μm	10 to 30%
#100 	149 microns	149 μm	2 to 10%
3/8 (9.51 mm) PEA GRAVEL AGGREGATE: Referred to as #4 Rock or Gravel or 1/2" minus (12.7 mm) size			
1/2" 	1/2"	12.70 mm	100%
3/8" 	3/8"	9.51 mm	85 to 100%
#4 	4,760 microns	4.76 mm	10 to 30%
#8 	2,380 micron	2.38 mm	0 to 10%
#16 	1,190 microns	1.19 mm	0 to 5%

APPENDIX — C-30HDN CONCRETE MIX INFORMATION

Consolidated Rock Products Co., Division of Tests

3/8" Pea Gravel STANDARD PUMP MIXES (one-half inch minus)

NOTE: All weights shown are one cubic yard with S.S.D. aggregates.

CRP Mix Number	6004	6005	6006	6007
Design Slump (in.)	6" (15 cm)	6" (15 cm)	6" (15 cm)	6" (15 cm)
Cement, SACK.	7.0	7.0	7.0	7.0
Cement, Lbs.	658 (298 kg)	658 (298 kg)	658 (298 kg)	658 (298 kg)
w/Con Sand (1 lb.)	2031 (920 kg)	2982 (943 kg)	1879 (851 kg)	1943 (880 kg)
Gravel #4(9.51 mm)	677 (307 kg)	693 (314 kg)	806 (365 kg)	832 (377 kg)
TOTAL AGGREGATE	2708 (1227 kg)	2775 (1257 kg)	2685 (1216 kg)	2775 (1257 kg)

ADMIXTURE

Pozzolith 311-1 lb.	1.4 (.63 kg)	1.4 (.63 kg)	1.4 (.63 kg)	—
Water, Design (gals.)	50.0 (189 liters)	53.0 (200 liters)	50.0 (189 liters)	53.9 (200 liters)
Mater, Max. (gals.)	50.0 (189 liters)	53.0 (200 liters)	53.0 (200 liters)	53.0 (200 liters)

NOTE: Multiply above kilograms and liters by 1.308 to obtain the proportions for one cubic meter of concrete.

Consolidated Rock Products Co., Division of Tests

3/8" Pea Gravel STANDARD PUMP MIXES (one-half inch minus)

NOTE: All weights shown are one cubic yard with S.S.D. aggregates.

CRP Mix Number	6000	6001	6002	6003
Design Slump (in.)	6" (15 cm)	6" (15 cm)	6" (15 cm)	6" (15 cm)
Cement, SACK.	6.5	6.5	6.5	6.5
Cement, Lbs.	611 (276 kg)	611 (276 kg)	611 (276 kg)	611 (276 kg)
w/Con Sand (1.1 lb.)	2062 (934 kg)	2112 (957 kg)	1924 (872 kg)	1971 (893 kg)
Gravel #4 (9.51mm)	687 (311 kg)	704 (319 kg)	825 (374 kg)	845 (383 kg)
TOTAL AGGREGATE	2749 (1245 kg)	2816 (1276 kg)	2749 (1245 kg)	2816 (1276 kg)

ADMIXTURE

Pozzolith 311-1.3lb.	1.3 (.59 kg)	1.3 (.59)	—		
Water, Design (gals.)	50.0 (189 liters)	53.0 (200 liters)	50.0 (189 liters)	53.9 (200 liters)
Mater, Max. (gals.)	50.0 (189 liters)	53.0 (200 liters)	53.0 (200 liters)	53.0 (200 liters)

NOTE: Multiply above kilograms and liters by 1.308 to obtain the proportions for one cubic meter of concrete.

APPENDIX — C-30HDN RECOMMENDED SHOTCRETE SYSTEM

RECOMMENDED SHOTCRETE SYSTEM

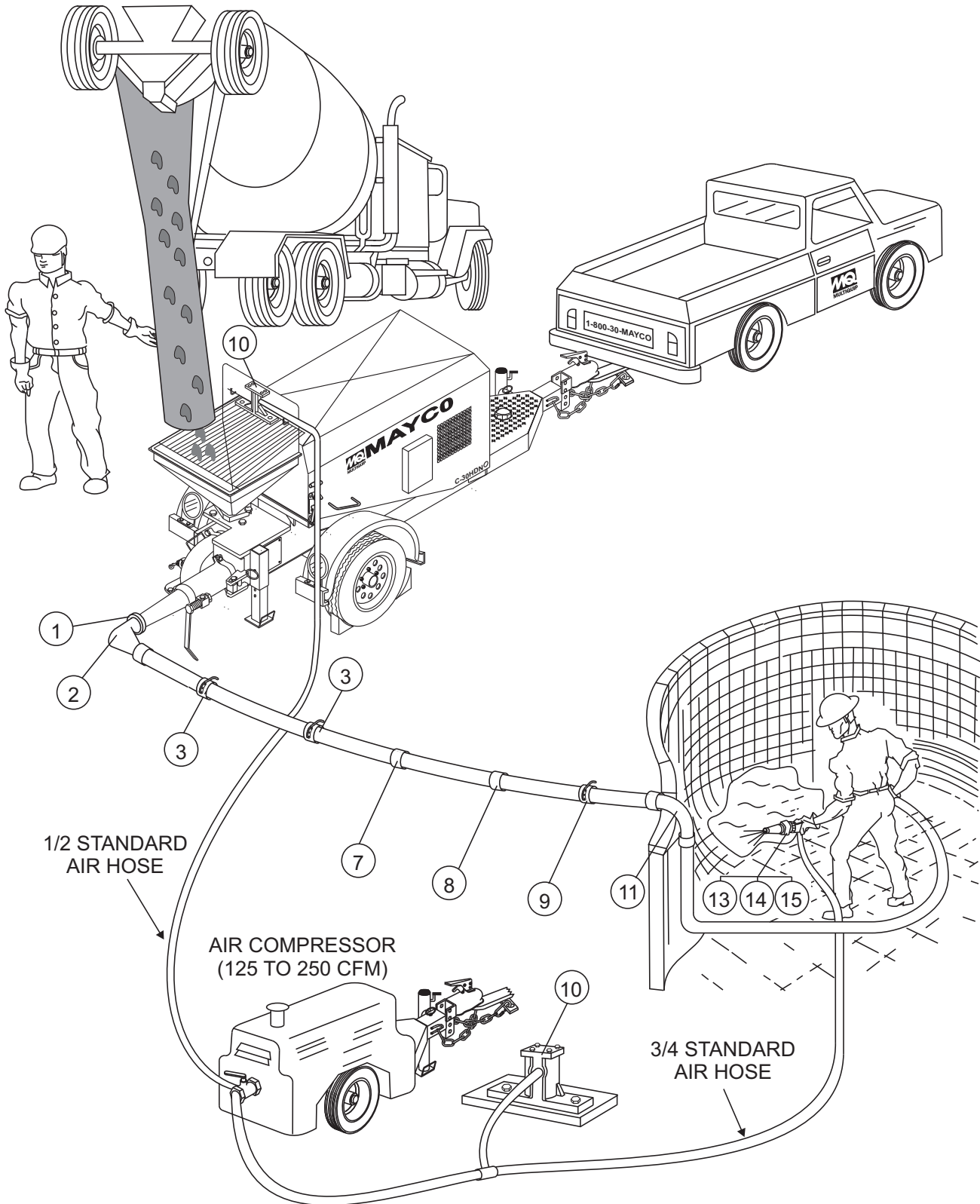

Figure 39. Shotcrete System

APPENDIX — C-30HDN RECOMMENDED SHOTCRETE SYSTEM

RECOMMENDED SHOTCRETE SYSTEM

<u>NO.</u>	<u>PART NO.</u>	<u>PART NAME</u>	<u>QTY.</u>	<u>REMARKS</u>
1	EM28904	3" "B" COUPLING		
2	EM23946	3"-90° ELBOW		
3	EM28903	2 1/2" S/J COUPLING		
4	EM28005DD	3"X 2 1/2 REDUCER		
5	EM28061	2 1/2"X 10FT. PIPE		
6	EM24849	2 1/2"X 50FT. HOSE		
7	EM28001DD	2 1/2"X 2" REDUCER		
8	EM23815D	2 1/2"X 2" REDUCER W/AIR VIBRATOR		
9	EM28902	2" S/J COUPLING		
10	EM23101	AIR VIBRATOR		
11	EM28131	2"X 2 ELBOW		
12	EM24841	2"X 25 FT. HOSE		
13	EM23808D.....	NOZZLE ASSEMBLY		
14	EM23806	1 3/8" NOZZLE TIP		
15	EM23807	1 1/4" NOZZLE TIP		

General recommendations

- If the site will permit, use steel pipe from the pump to the pool perimeter. It will reduce line pressures which is highly recommended.
- The vibrator on the reducer by the pool improves pumpability.
- Turn both air vibrators off whenever the pump is stopped to prevent separation of mix.
- The air vibrators are low consumption (4.2 scfm).
- Leave the air on at the nozzle when the pump is stopped to prevent clogging of air the hoses in the air insert.
- Use item #11 (steel elbow) at the edge of the pool to prevent collapse of the rubber hose, which can cause blockage.

APPENDIX — C-30HDN RECOMMENDED SHOTCRETE ACCESSORIES

RECOMMENDED SHOTCRETE ACCESSORIES

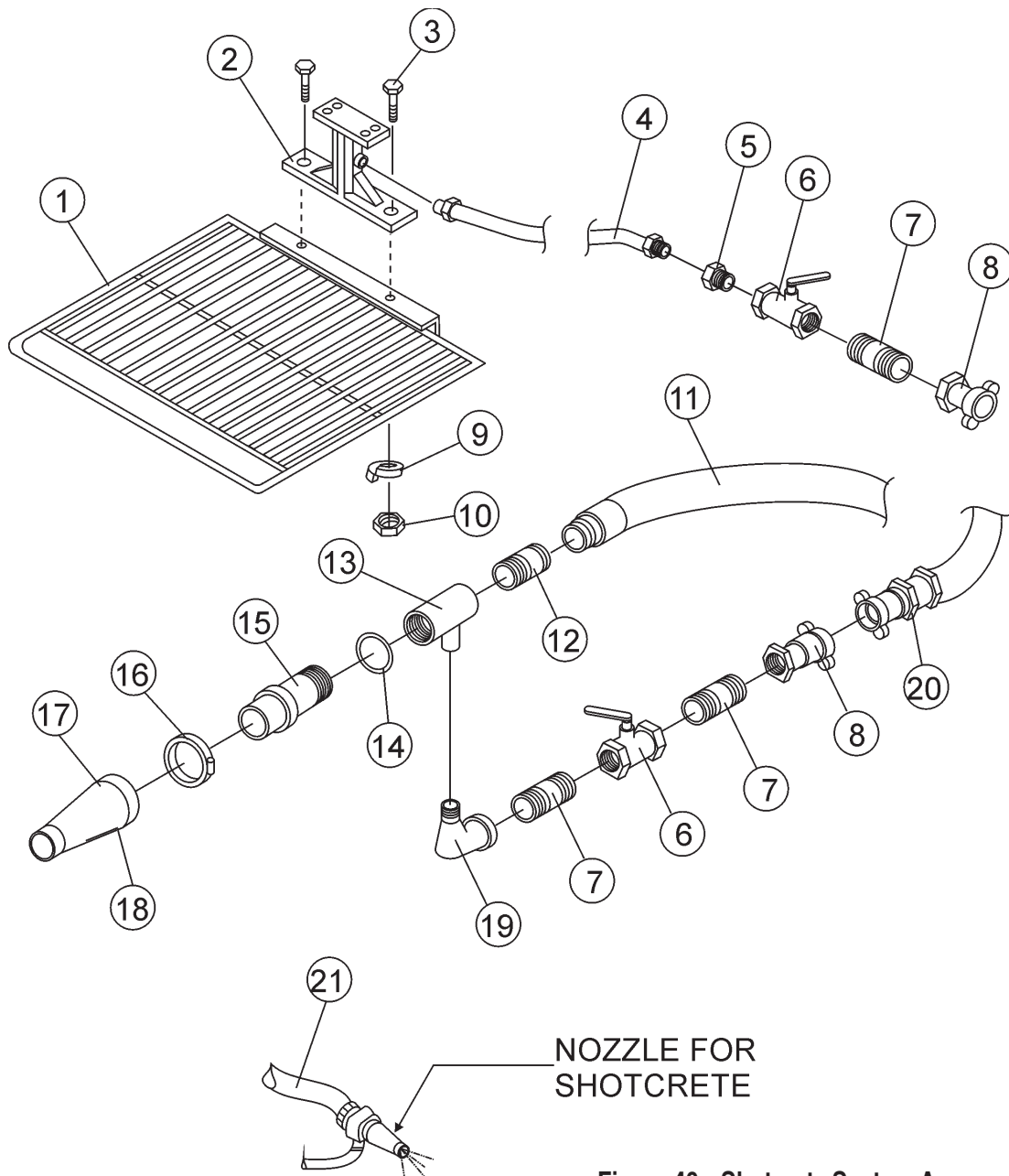
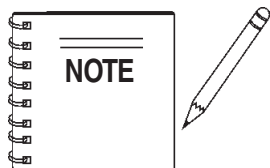

Figure 40. Shotcrete System Accessories



Use a 1-3/8" rubber nozzle tip for a wide spray pattern. Use a 1-1/4" rubber nozzle tip for a narrow spray pattern. **DO NOT INSTALL THE NOZZLE AT THE END OF THE HOSE UNTIL THE FIRST MATERIAL HAS PASSED THROUGH THE ENTIRE HOSE LENGTH.**

Disassemble and clean the nozzle assembly thoroughly after each job. Grease all threads before re-assembly. **DO NOT** close the air valve when pumping is stopped as a continued air flow keeps the air passages clean.

APPENDIX — C-30HDN RECOMMENDED SHOTCRETE ACCESSORIES

RECOMMENDED SHOTCRETE ACCESSORIES

<u>NO.</u>	<u>PART NO.</u>	<u>PART NAME</u>	<u>QTY.</u>	<u>REMARKS</u>
1	EM26107	HOPPER SCREEN	1	
2	EM231011	AIR VIBRATOR	1	
3	EM132	BOLT, 1/2-13X2	2	
4	EM23407	AIR HOSE	1	
5	EM23408	BUSHING	1	
6	EM23411	VALVE	1	
7	EM912073	NIPPLE	2	
8	EM23409	COUPLING	1	
9	EM923346	WASHER, 1/2 LOCK	2	
10	EM406	NUT, HEX 1/2-13	2	
11	EM23818	2"X25' GROOVED HOSE		
	EM24841	2"X25' RAISED HOSE		
	EM23845	2"X50' GROOVED HOSE		
12*	EM23802	ADAPTER	1	
13*	EM23803	GUN BODY	1	
14*	EM20816	"O" RING	1	
15*	EM23804	AIR INSERT	1	
16*	EM23805	NOZZLE CLAMP	1	
17*	EM23806	NOZZLE TIP, 1-3/8"	1	
18*	EM23807	NOZZLE TIP, 1-1/4"	1	
19*	EM911076	STREET ELBOW	1	
20		AIR HOSE		NOT SUPPLIED BY MAYCO
21	EM23808	NOZZLE ASSEMBLY	1	INCLUDES. ITEMS W/*

APPENDIX — C-30HDN C-30HDN SLUMP TEST PROCEDURE

1. To obtain a representative sample (concrete), take several samples at three or more regular intervals throughout the discharge of the mixer or truck. **DO NOT** take samples at the beginning or end of the discharge.
2. Dampen the inside of the cone and place it on a smooth, moist, nonabsorbent, level surface large enough to accommodate both the slumped concrete and the slump cone. Stand on the “foot pieces” throughout the test procedure to hold the cone firmly in place.
3. Fill the cone 1/3 full by volume (Figure 41-A) and rod 25 times with a 1/2” dia x 24” lg. bullet-pointed steel rod. (This is a specific requirement which will produce non-standard results unless followed exactly.) Distribute rodding evenly over the entire cross section of the sample.
4. Fill cone another 1/3 (Figure 41-B) which will make the cone 2/3 full by volume. Rod this second layer 25 times with the rod penetrating into, but not through, the first layer. Distribute rodding evenly over the entire cross section of the layer.
5. Fill cone to overflowing (Figure 41-C). Rod this layer 25 times with rod penetrating into but not through, the second layer. Distribute rodding evenly over the entire cross section of this layer.
6. Remove the excess concrete (Figure 41-D) from the top of the cone, using the tamping rod as a screed.
7. Lift the cone vertically (Figure 41-E) with a slow even motion. **DO NOT** jar the concrete or tilt the cone during this process. (Invert the withdrawn cone, and place it next to, but not touching the slumped concrete.)
8. Lay a straight edge (Figure 41-F) across the top of the slumped cone. Measure the amount of slump in inches from the bottom of the straight edge to the top of the slumped concrete at a point over the original center of the base. The slump operation must be complete in a maxi-

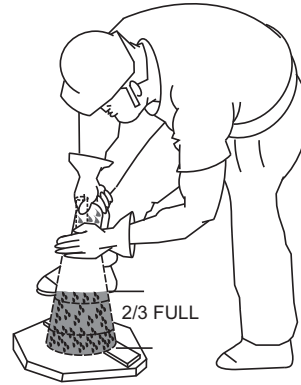

Figure 41-B. Slump Test (2/3 Full)

Figure 41-C. Slump Test (Full-Overflow)

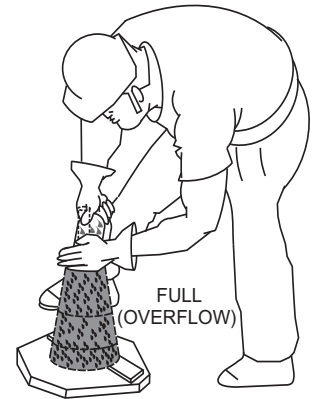

Figure 41-D. Slump Test (Removing Excess Concrete)

Figure 41-E. Slump Test (Cone Invert)

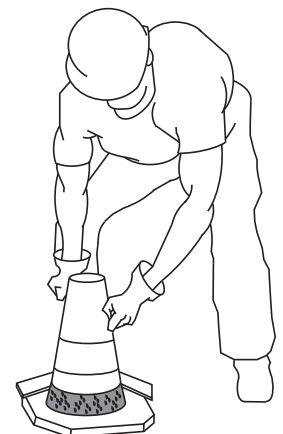

Figure 41-F. Slump Test (Measurement)

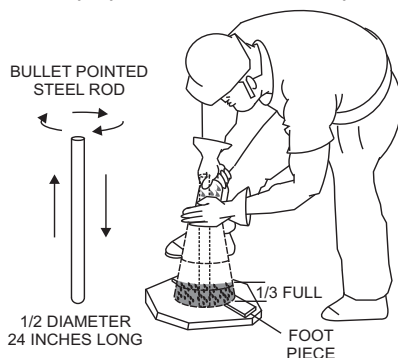

Figure 41-A. Slump Test (1/3 Full)

OPERATION MANUAL

HERE'S HOW TO GET HELP

PLEASE HAVE THE MODEL AND SERIAL
NUMBER ON-HAND WHEN CALLING

UNITED STATES

Multiquip Inc.

(310) 537- 3700
6141 Katella Avenue Suite 200
Cypress, CA 90630
E-MAIL: mq@multiquip.com
WEBSITE: www.multiquip.com

CANADA

Multiquip

(450) 625-2244
4110 Industriel Boul.
Laval, Quebec, Canada H7L 6V3
E-MAIL: infocanada@multiquip.com

UNITED KINGDOM

Multiquip (UK) Limited Head Office

0161 339 2223
Unit 2, Northpoint Industrial Estate, Globe Lane,
Dukinfield, Cheshire SK16 4UJ
E-MAIL: sales@multiquip.co.uk

© COPYRIGHT 2024, MULTIQUIP INC.

Multiquip Inc, the MQ logo are registered trademarks of Multiquip Inc. and may not be used, reproduced, or altered without written permission. All other trademarks are the property of their respective owners and used with permission.

This manual MUST accompany the equipment at all times. This manual is considered a permanent part of the equipment and should remain with the unit if resold.

The information and specifications included in this publication were in effect at the time of approval for printing. Illustrations, descriptions, references and technical data contained in this manual are for guidance only and may not be considered as binding. Multiquip Inc. reserves the right to discontinue or change specifications, design or the information published in this publication at any time without notice and without incurring any obligations.

