

SERVICE BULLETIN

Group: MP

Mandatory

Information

Recommended Change

Series/Parts Affected:

Fuel Suction Tube

Machines Affected:

Up to Serial Number 250115 (January, 2005)

PROBLEM

The Nissan engine will not stay running. This may cause fuel pump to overheat.

PROBABLE CAUSE

It was discovered that during hot weather, the poly fuel tank will slightly warp causing the tank bottom to touch the fuel suction tube. This restricts the fuel flow to the pump thus starving the engine.

CORRECTIVE ACTION

1. Disconnect the fuel hose from the barb fitting located on the fuel suction tube.
2. Using a 9/16-inch deep socket, remove the suction tube from the tank.
3. Modify the tube by cutting a 45° angle cut. See Figure 1.
4. Make sure that the angle cut is not left sharp. A sharp cut will eventually wear a hole in the tank.
5. Place the modified suction tube back into the fuel tank and reconnect the fuel hose to the barb fitting.

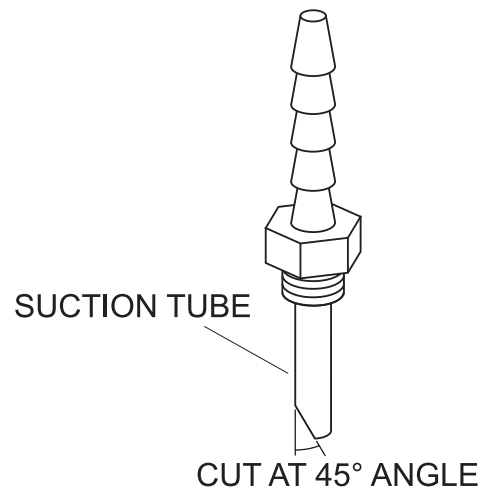

Figure 1. Suction Tube

WARRANTY INFORMATION

Campaign Reference No. 20050628
 Please contact Chris Fairchild or George Manrique @ 1-800-421-1244 for warranty claim number and warranty form.

Labor Allowance: Flat Rate to install - 30 minutes