

OPERATION MANUAL

STOW

A DIVISION OF MULTIQUIP INC.

MODELS

CS403016

CS403020

CS403026

CS403030

PAVEMENT SAW

(DEUTZ F2L2011 DIESEL ENGINE)

Revision #0 (02/29/08)

To find the latest revision of this
publication, visit our website at:
www.multiquip.com



THIS MANUAL MUST ACCOMPANY THE EQUIPMENT AT ALL TIMES.

P/N 37747



WARNING



CALIFORNIA — Proposition 65 Warning

Engine exhaust and some of its constituents, and some dust created by power sanding, sawing, grinding, drilling and other construction activities contains chemicals known to the State of California to cause cancer, birth defects and other reproductive harm. Some examples of these chemicals are:

- Lead from lead-based paints.
- Crystalline silica from bricks.
- Cement and other masonry products.
- Arsenic and chromium from chemically treated lumber.

Your risk from these exposures varies, depending on how often you do this type of work. To reduce your exposure to these chemicals: **ALWAYS** work in a well ventilated area, and work with approved safety equipment, such as dust masks that are specially designed to filter out microscopic particles.

WARNING



SILICOSIS WARNING

Grinding/cutting/drilling of masonry, concrete, metal and other materials with silica in their composition may give off dust or mists containing crystalline silica. Silica is a basic component of sand, quartz, brick clay, granite and numerous other minerals and rocks. Repeated and/or substantial inhalation of airborne crystalline silica can cause serious or fatal respiratory diseases, including silicosis. In addition, California and some other authorities have listed respirable crystalline silica as a substance known to cause cancer. When cutting such materials, always follow the respiratory precautions mentioned above.

WARNING

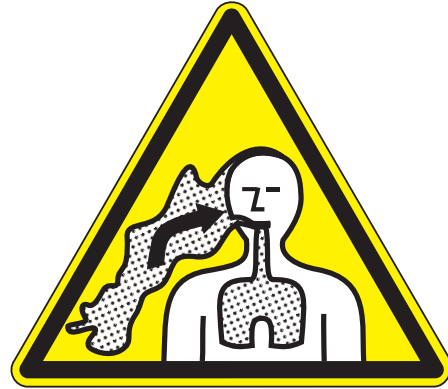

RESPIRATORY HAZARDS

Grinding/cutting/drilling of masonry, concrete, metal and other materials can generate dust, mists and fumes containing chemicals known to cause serious or fatal injury or illness, such as respiratory disease, cancer, birth defects or other reproductive harm. If you are unfamiliar with the risks associated with the particular process and/or material being cut or the composition of the tool being used, review the material safety data sheet and/or consult your employer, the material manufacturer/supplier, governmental agencies such as OSHA and NIOSH and other sources on hazardous materials. California and some other authorities, for instance, have published lists of substances known to cause cancer, reproductive toxicity, or other harmful effects.

Control dust, mist and fumes at the source where possible. In this regard use good work practices and follow the recommendations of the manufacturers or suppliers, OSHA/NIOSH, and occupational and trade associations. Water should be used for dust suppression when wet cutting is feasible. When the hazards from inhalation of dust, mists and fumes cannot be eliminated, the operator and any bystanders should always wear a respirator approved by NIOSH/MSHA for the materials being used.

STOW CS4030 SAW — TABLE OF CONTENTS

Table of Contents	4
Dimensions	5
Specifications	6
Engine Specifications	7
Training Checklist	8
Daily Pre-Operation Checklist	9
Safety Message Alert Symbols	10-11
Rules For Safe Operation	12-16
Intended Use/Familiarization	17
Operation And Safety Decals	18
Serial Tag Information	19

STOW — CS4030 SAW

Controls and Indicators	20
Components	21
Basic Engine Information	22
Choosing Proper Blade Size	23-24
Specific Tools/Saw Blades	25
Installing the Blade	26-27
Blade Guards	28-29
Water Delivery System	30
Battery	31
Fueling the Saw	32
Pointer Adjustment	33
Raise/Lower Controls	34
Blade Shaft Engage/Dis-engage	35
Operation	36-37
Loading/Transporting	38
Maintenance	39-55
Troubleshooting	56-58
Wiring Diagram	60
Terms and Condition of Sale	61

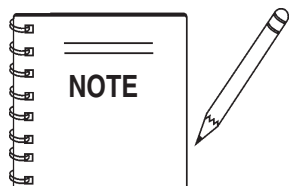

Specifications are subject to change without notice.

STOW CS4030 SAW — DIMENSIONS

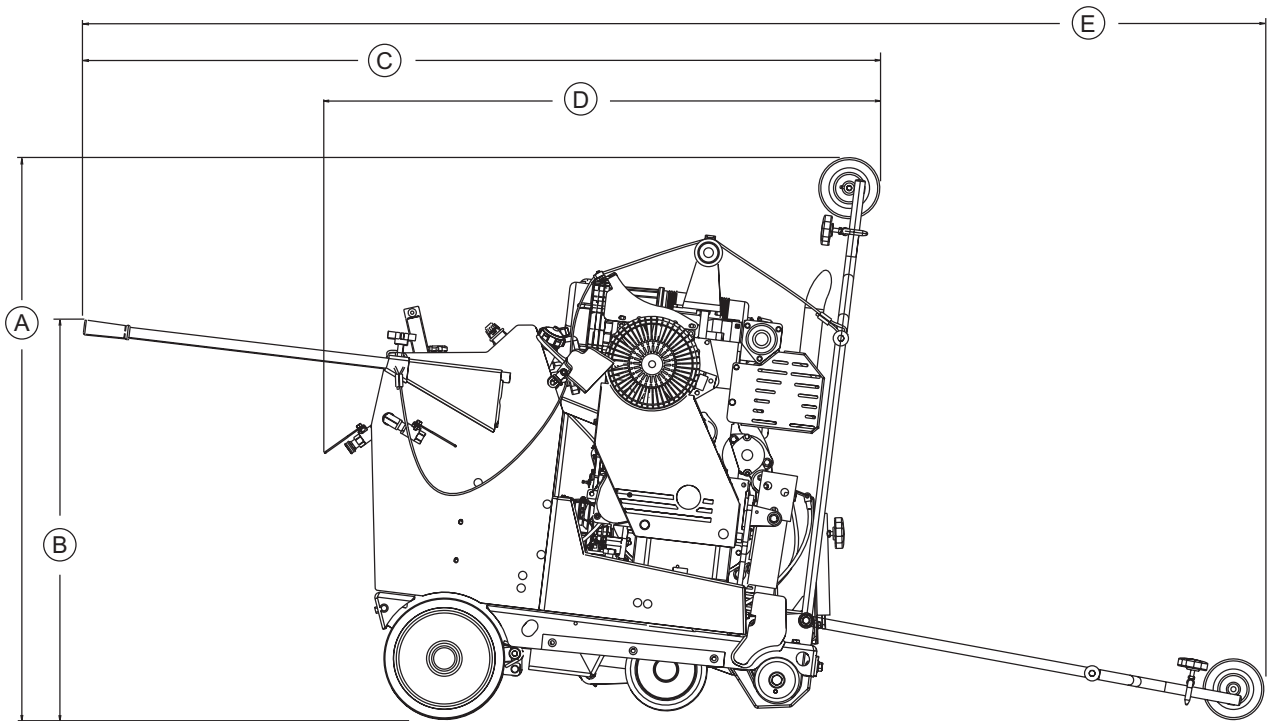

Figure 1. Chassis & Dimensions - Sideview

TABLE 1. CHASSIS & DIMENSIONS

REFERENCE LETTER	DESCRIPTION	DIMENSIONS in. (mm)
A	Max Height (Raised/Front Pointer up)	71 in. (1803 mm)
B	Max Handle Bar Height	47 in. (119 mm)
C	Max Length (Handle Bars Installed & Front Pointer fully raised)	88 in. (2235 mm)
D	Length (Handle Bars not Installed & Front Pointer fully raised)	63 in. (1600 mm)
E	Max Length (Handle Bars Installed & Front Pointer lowered)	116 in. (2946 mm)
F	Max Width (Blade Guards Removed)	31 in. (787 mm)
G	Frame Width	25 in. (64 mm)
H	Frame Length	43.5 in. (110 mm)
I	Front Wheel Width	23.5 in. (60 mm)
J	Rear Wheel Width	23.5 in. (60 mm)
K	Blade Shaft Inner Flange to Inner Flange Width	28.5 in. (72 mm)
	Handlebars	Tri-Position System
	Console Mounting	Vibration Control System
	Chassis	Cold-Formed Welded Box Construction
	Night Light	Optional
Crated Dimension (L x W x H): 60 x 43 x 64 in. (1525 x 1090 x 1625 mm)		

STOW CS4030 SAW — SPECIFICATIONS

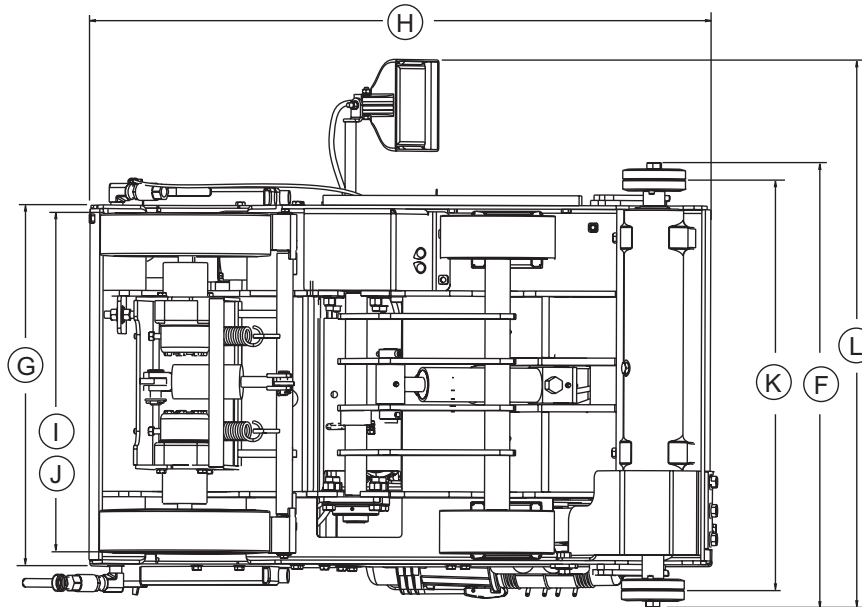

Figure 2. Chassis & Dimensions - Bottomview

TABLE 2. BLADE AND SHAFT SPECIFICATIONS

Blade Shaft Assembly	Oil bath design, fully enclosed cast iron housing
Blade Shaft Bearings	Oil lubricated, no lubrication requirements
Blade Shaft Diameter	2-3/8 in. (60mm)
Arbor Diameter	1 in. (25.4 mm)
Blade Flanges	Quick disconnect system, inner flanges mounted to shaft
Blade Flange Sizes	4-1/2 in. and 5 in. (114mm and 127 mm)
Drive Belt	(1) 6G 3VX-500 multi-groove belt
Max. Blade Raise Height	17.5 in. (445 mm)
Blade Mounting	Left or Right
Max. Blade Diameter	30 in. (762 mm)
Max. Depth of Cut	12.5 in. (318 mm)
Blade Guard Capacity	16-30 in. (406 mm-762 mm)
Blade Guard	Slip-on, tapered mount
Blade Raise-Lower	Electro-hydraulic pump
Water Control	Water valves on both sides of saw
Water Distribution	Dual water lines directly deliver water to blade

STOW CS4030 SAW — ENGINE SPECIFICATIONS

TABLE 3. ENGINE / MOTOR SPECIFICATIONS

Engine Manufacture	Deutz
Model	F2L 2011
Max RPM	3000
Horsepower / Max kW	31.3 hp / 23.0 kW
Peak Torque	66.3 lb./ft. (90 Nm)
Fuel	Diesel
Fuel Capacity	6.0 gallons / 22.7L
Air Filter	Dual element radial seal with integral turbo pre-cleaner
Oil Capacity	7 Qts. (6.6L)
Engine Coolant	Oil to Air

TABLE 4. TRANSMISSION SYSTEM SPECIFICATIONS

Transmission Pump	Hydro-gear hydrostatic transmission pump
Wheel Motors	Hydro-gear hydrostatic wheel motors
Travel Speed	0-275 FPM / 0-84 MPM, infinitely variable
Brakes	Automatic actuating parking brake
Wheels Rear	12 in x 3 in. (305 mm x 76 mm)
Wheels Front	8 in x 3 in. (203 mm x 76 mm)

TABLE 5. WEIGHTS

Uncrated Weight	1398 lbs. (634.1Kg)
Crated Weight	1498 lbs. (679.5Kg)

TRAINING CHECKLIST

TRAINING CHECKLIST

This checklist lists the minimum requirements for machine maintenance and operation. Please feel free to detach it and make copies. Use this checklist when training a new operator or use as a review for more experienced operators.

TRAINING CHECKLIST			
NO.	DESCRIPTION	OK?	DATE
1	Read Operator's Manual completely.		
2	Machine layout, location of components, checking of engine and hydraulic oil levels.		
3	Fuel system, refueling procedure.		
4	Operation of spray and lights.		
5	Operation of controls (machine not running).		
6	Safety controls, safety stop switch operation.		
7	Emergency stop procedures.		
8	Startup of machine, pre-heat, engine choke.		
9	Forward and Reverse Travel.		
10	Starting a cut.		
11	Pavement Cutting techniques.		
12	Stopping a cut.		
13	Re-start after stopping blade within work surface - explanation.		
14	Shutdown of machine.		
15	Lifting of machine (lift loops).		
16	Machine transport and storage.		

Operator _____ Trainee _____

COMMENTS:

DAILY PRE-OPERATION CHECKLIST

DAILY PRE-OPERATION CHECKLIST

DAILY PRE-OPERATION CHECKLIST		✓	✓	✓	✓	✓	✓
1	Hardware and damage check.						
2	Engine oil level.						
3	Hydraulic oil level.						
4	Condition of blade.						
5	Safety Stop Switch operation.						
6	Braking control operation.						

COMMENTS:

SAFETY MESSAGE ALERT SYMBOLS

FOR YOUR SAFETY AND THE SAFETY OF OTHERS!

Safety precautions should be followed at all times when operating this equipment. Failure to read, understand and comply with the Safety Messages and Operating Instructions could result in injury to yourself and others.

This Operation Manual has been developed to provide instructions for the safe and efficient operation of the STOW CS4030 Saw. For engine maintenance information, please refer to the engine manufacturer's instructions for data relative to its safe operation.



Before using this Saw, ensure that the operating individual has read, understands, and complies with all instructions in this manual.

SAFETY MESSAGE ALERT SYMBOLS

The three (3) Safety Messages shown below will inform you about potential hazards that could injure you or others. The Safety Messages specifically address the level of exposure to the operator, and are preceded by one of three words: **DANGER**, **WARNING**, or **CAUTION**.

DANGER

You **WILL** be **KILLED** or **SERIOUSLY INJURED** if you **DO NOT** follow these directions.

WARNING

You **CAN** be **KILLED** or **SERIOUSLY INJURED** if you **DO NOT** follow these directions.

CAUTION

You **CAN** be **INJURED** if you **DO NOT** follow these directions.

Potential hazards associated with Saw operation will be referenced with Hazard Symbols which appear throughout this manual, and will be referenced in conjunction with Safety Message Alert Symbols.

HAZARD SYMBOLS

Lethal Exhaust Gases



Engine exhaust gases contain harmful toxins and will displace oxygen when running in an enclosed or confined area. **NEVER** operate this equipment in a confined area or enclosed structure that does not provide ample free flow air.

Explosive Fuel



Diesel fuel is flammable, and its vapors can cause an explosion if ignited. **DO NOT** start the engine near spilled fuel or combustible fluids. **DO NOT** fill the fuel tank while the engine is running or hot. **DO NOT** overfill tank, since spilled fuel could ignite if it comes into contact with hot engine parts or sparks from the ignition system. Store fuel in approved containers, in well-ventilated areas and away from sparks and flames. **NEVER** use fuel as a cleaning agent.

Burn Hazards



Engine components can generate extreme heat. To prevent burns, **DO NOT** touch these areas while the engine is running or immediately after operations. **NEVER** operate the engine with heat shields or heat guards removed.

Rotating Parts



NEVER operate equipment with covers, or guards removed. Keep **fingers, hands, hair** and **clothing** away from all moving parts to prevent injury.

Skin Injection Hazard



NEVER use your hand to find hydraulic leaks. Use a piece of wood or cardboard. Hydraulic fluid injected into the skin must be treated by a knowledgeable physician immediately or severe injury or death can occur.

SAFETY MESSAGE ALERT SYMBOLS



Accidental Starting

Accidental starts can cause severe injury or death. **ALWAYS** place the ON/OFF switch in the OFF position. Disconnect negative battery cable from battery before servicing.



Over Speed Conditions



NEVER tamper with the factory settings of the engine governor or settings. Personal injury and damage to the engine or equipment can result if operating in speed ranges above maximum allowable.



Rotating Blade

Rotating blade can cut and crush. Keep hands and feet clear.



Guards and Covers In Place

NEVER operate the saw without blade guards and covers in place. Adhere to safety guidelines and applicable local regulations.



Crush Hazard

ALWAYS ensure saw is **SECURELY** placed on appropriate blocks or jackstands when performing maintenance requiring the saw to be elevated.

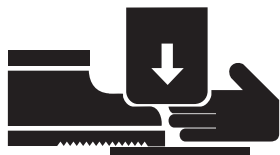

Respiratory Hazard



ALWAYS wear approved respiratory protection.



Sight and Hearing hazard

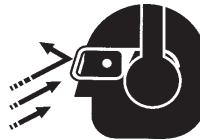

ALWAYS wear approved eye and hearing protection.



Equipment Damage Messages

Other important messages are provided throughout this manual to help prevent damage to your saw, other property, or the surrounding environment.

STOW CS4030 SAW — RULES FOR SAFE OPERATION

RULES FOR SAFE OPERATION

WARNING

Failure to follow instructions in this manual may lead to serious injury or even death! This equipment is to be operated by trained and qualified personnel only! This equipment is for industrial use only.

The following safety guidelines should always be used when operating the STOW CS4030 SAW .

SAFETY

- **DO NOT** operate or service this equipment before you read, understand, and comply with all safety messages in this manual. The manual must be kept available and accessible to the operator.



- This equipment should not be operated by persons under the minimum statutory age limit.
- **NEVER** use this machine for any purpose other than those described in this manual.
- **NEVER** operate the saw without proper protective clothing, shatterproof glasses, steel-toed boots and other protective devices required for the job.



- **NEVER** use accessories or attachments which are not recommended by the manufacturer for this equipment. Damage to the equipment and/or injury to user may result.
- Manufacturer does not assume responsibility for any accident due to equipment modifications. Unauthorized equipment modification will void all warranties. Any modification which could lead to a change in the original characteristics of the machine should be made only by the manufacturer who shall confirm that the machine is in conformity with appropriate safety regulations.

- **NEVER** operate this equipment when not feeling well due to fatigue, illness or taking medicine.
- **NEVER** operate the saw under the influence of drugs or alcohol.
- **AVOID** wearing jewelry or loose fitting clothing that may snag on the controls or moving parts, this can cause a serious injury.
- Replace operation and safety decals when they become difficult to read.
- The engine of this saw requires an adequate free flow of cooling air. **NEVER** operate the saw in any enclosed or narrow area where free flow of the air is restricted. If the air flow is restricted it will cause serious damage to the engine and may cause injury to people. Remember the engine can give off harmful toxins and will displace oxygen.

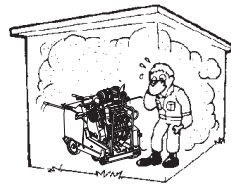

- Make certain the operator knows how to and is capable of turning the engine OFF in case of an emergency.
- Turn engine OFF prior to fueling the saw.
- **ALWAYS** refuel in a well-ventilated area, away from sparks and open flames.
- Topping-off to filler port is dangerous, as it tends to spill fuel.
- **NEVER** use fuel as a cleaning agent.
- **ALWAYS** use extreme caution when working with **flammable** liquids. Allow the engine to cool before adding fuel or performing service and maintenance functions.

- **NEVER** operate the saw in an explosive atmosphere where fumes are present, or near combustible materials. An explosion or fire could result in severe **bodily harm or even death**.

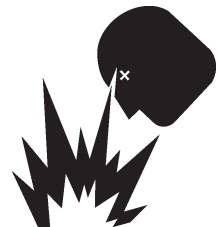

- **NEVER** smoke around or near the machine. Fire or explosion could result from **fuel vapors**, or if fuel is spilled on a **hot!** engine.



STOW CS4030 SAW — RULES FOR SAFE OPERATION

- **ALWAYS** keep the work area well organized.
- Keep the saw clean. It will perform better and last longer.
- **ALWAYS** Clear the cutting area of any debris, tools, etc. that would constitute a hazard while the saw is in operation.

WARNING

ALWAYS check to make sure that the cutting area is clear before starting the engine.



- Keep all inexperienced and unauthorized people clear of the cutting area when operating the saw.
- No one other than the operator is to be in the working area when the saw is in operation.
- **NEVER** allow passengers or riders on the saw during operation or transportation.
- **ALWAYS** check the saw for loosened hardware such as nuts and bolts before starting.
- **NEVER** run the engine without the air filter. Severe engine damage could occur. Service air cleaner at recommended service intervals to prevent engine damage.
- Make certain all protective guards are securely in place **BEFORE** operating the saw. This saw is supplied with a blade guard, blade flange guard, and a belt guard.
- **NEVER** place your **feet** or **hands** inside the guards while starting or operating this equipment.
- **DO NOT** go near rotating parts, (blades, belts, pulleys or wheels), while engine is running.
- **Moving Parts** – Shut down the engine before performing service or maintenance functions. Contact with moving parts can cause serious injury.



- **NEVER** touch the hot exhaust manifold, muffler or cylinder. Allow these parts to cool before servicing the saw. Contact with **hot!** components can cause serious burns.



DANGER

Pay close attention to ventilation when operating the saw in confined spaces such as tunnels, buildings or similar areas. The engine exhaust contains harmful elements. Ensure proper air flow to move engine exhaust away from the operator.



- Verify the engine start switch is set to the OFF position before installing a blade.
- Use proper blades and follow the blade manufacturer's recommendations. Match the blade RPM (Blade Shaft RPM) to the recommended blade surface feet per minute. (SFPM).
- Ensure the 5/8" blade-mounting bolt is tightened to 125-175 foot lbs. of torque.
- **NEVER** leave the machine **unattended** while running.
- Ensure brakes are applied when leaving or when using on a slope. This saw utilizes a brake system where the brakes are automatically applied when the engine is stopped.
- Start engine with the Control Handle in the NEUTRAL position to prevent unexpected saw movement.
- Do not start engine on a sloping surface to prevent unexpected loss of control.
- **DO NOT** use on excessive slopes or on extremely uneven surfaces.
- If the saw must be parked on a slope and engine turned off, ensure the parking brake is engaged and holds the saw safely in place. Turning the saw across the angle of the slope will help prevent accidental downhill movement. Block the saw as well when leaving.

STOW CS4030 SAW — RULES FOR SAFE OPERATION

- Always store equipment properly when not being used. Equipment should be stored in a clean, dry location out of the reach of children. When storing the saw in freezing weather, blow out the water lines to prevent damage to components in the water delivery system.
- **DON'T POLLUTE!** Waste Oils and other chemicals must be disposed of in a manner consistent with local and state environmental protection regulations.
- Always observe all applicable compulsory regulations relevant to environmental protection, especially fuel storage, the handling of hazardous substances, and the wearing of protective clothing and equipment. Instruct the user as necessary, or, as the user, request this information and training.

Diamond Blade Safety

- Use appropriate steel-centered diamond blades manufactured for particular use on your saw. See further blade information in this manual.

WARNING

ALWAYS inspect diamond blades before each use. The blade should exhibit no cracks, dings, or flaws in the steel centered core and/or rim. Center (arbor) hole must be undamaged and true.



- Examine blade flanges for damage and excessive wear.
- Ensure the cleanliness of the blade before blade is installed. Blade should fit snugly on the shaft and against the inside/outside blade flanges.
- Ensure the blade is marked with an operating speed greater than the spindle speed of the saw.
- Only cut the material that is specified for the diamond blade. Read the specifications of the diamond blade to ensure the proper tool has been matched to the material being cut. The saw has been engineered for **WET CUTTING**. Ensure a **WET CUTTING** blade is being used and that the water supply system to the blade is properly functioning and being used.
- **ALWAYS** keep blade guards in place. Exposure of the diamond blade must not exceed 180 degrees.
- Ensure that the diamond blade does not come into contact with the ground or surface during transportation. **DO NOT** drop the diamond blade on ground or surface.
- The engine governor is set to permit maximum engine speed in a no-load condition. Do not tamper with the engine governor to increase the speed. Increasing the engine speed could allow the maximum rated spindle speed to be exceeded, creating an unsafe condition.
- Ensure that the blade is mounted for proper operating direction.
- Adhere to the Blade Manufacturer's recommendations on handling, storage, and safe usage of blades.

STOW CS4030 SAW — RULES FOR SAFE OPERATION

Saw Lifting and Loading Safety

CAUTION

This Saw is very *heavy*. Use proper heavy lifting procedures and **DO NOT** attempt to lift the saw by the guards.

DANGER

NEVER stand under or allow anyone else to stand under the saw while it is being lifted.

- **DO NOT** use the handle bars and/or front pointer as lifting points.
- **ALWAYS** use ramps capable of supporting the weight of the saw and the operator to load and unload the saw. If the saw must be lifted, always use two people. Never attempt to lift the saw by yourself.
- **NEVER** tip the engine to extreme angles as it may cause oil to gravitate into the cylinder head making the engine start difficult.
- **NEVER** transport the saw to or from the job site with the blade mounted.

Transporting (Via truck/trailer)

- **ALWAYS** shutdown engine before transporting.
- Tighten fuel tank cap securely and close fuel petcock to prevent fuel from spilling.
- Drain fuel when transporting saw for long distances or over bad roads.
- Use appropriate lifting equipment to ensure the safe movement of the saw.
- Do not use the handlebars or front pointer as lifting points.
- When placing the saw on a truck-bed for transport, *always* tie-down the saw.
- Do not use the handlebars or front pointer as tie-down points.
- Never attempt to tow the saw untrailerred behind a vehicle.
- Never transport the saw with the blade mounted.
- If the saw is being transported via a trailer, make sure the trailer complies with all local and state safety transportation laws. Refer to the following "**Towing Safety Precautions**" for basic towing techniques.

Towing Safety Precautions (Trailer Usage)

CAUTION

Conform to **Department of Transportation (DOT) Safety Towing Regulations** before transporting saw on public roads.

To reduce the possibility of an accident while transporting the saw on public roads, always make sure the trailer that supports the saw and the towing vehicle are in good operating condition and both units are mechanically sound.

The following list of suggestions should be used when towing your saw:

- Check the tire air pressure on both towing vehicle and trailer. Refer to the tire manufacturer's recommended pressure. Also check the tire tread wear on both vehicles.
- Make sure the hitch and coupling of the towing vehicle are rated equal to, or greater than the trailer "gross vehicle weight rating" (GVWR) of 6,000 lbs.
- **ALWAYS** inspect the hitch and coupling for wear. **NEVER** tow a trailer with defective hitches, couplings, chains, etc.
- **ALWAYS** make sure the trailer is equipped with "**Safety Chains**" and ensure they are attached properly.
- **ALWAYS** make sure the vehicle and trailer directional, backup, brake, and trailer lights are connected and working
- **DO NOT** exceed the recommended highway speed when towing.
- Use chock-blocks at each wheel when parked to prevent trailer from rolling.
- Use the trailer's swivel jack to adjust the trailer height to a level position while parked.
- Avoid sudden stops and starts. This can cause the trailer to skid or jack-knife. Smooth, gradual starts and stops will improve towing.
- Avoid sharp turns.
- Trailer should be adjusted to a level position at all times when towing.
- Raise and lock trailer wheel stand in the "**UP**" position when transporting.
- DOT requirements include the following:
 - Connect and test electric brake operation.
 - Secure portable power cables in cable tray with tie wraps.

STOW CS4030 SAW — RULES FOR SAFE OPERATION

Battery

The battery contains acids that can cause injury to the eyes and skin. To avoid eye irritation, **always** wear safety glasses or face shielding. Use well insulated gloves when picking the battery up. Use the following guidelines when handling the battery.

- **DO NOT** drop the battery. Any impact to the battery may cause it to explode.
- **DO NOT** expose the battery to open flames, sparks, lit cigarettes etc. The battery contains combustible gases and liquids. If these gases and liquids come in contact with a flame or spark an explosion can occur.
- **ALWAYS** keep the battery charged. If the battery is not charged a buildup of combustible gas will occur.
- **ALWAYS** recharge the battery in a vented air environment to avoid risk of a dangerous concentration of combustible gases.
- **ALWAYS** keep battery cables in good working condition. Repair or replace all worn cables.
- Disconnect battery cables before inspecting electrical system and never "spark" battery terminals to test for charge.
- In case the battery liquid (dilute sulfuric acid), comes in contact with **clothing or skin**, rinse skin or clothing immediately with plenty of water.
- In case the battery liquid, (dilute sulfuric acid), comes in contact with your **eyes**, rinse eyes immediately with plenty of water, then contact the nearest doctor or hospital and seek medical attention.

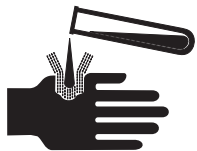
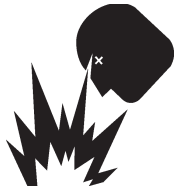

- **ALWAYS** allow the saw a proper amount of time to cool before servicing.
- Prior to service, level the frame surface.
- Anytime the saw is lifted onto its nose, or tilted fully back such as for maintenance access, the high end of the saw **MUST** be blocked up to prevent the possibility of crush injury.
- Make sure that there is no buildup of concrete, grease, oil or debris on the machine.
- Repair damage to the saw immediately and always replace broken parts.
- Dispose of hazardous waste properly. Examples of potentially hazardous waste are used motor oil, fuel and fuel filters.
- **DO NOT** use plastic food containers to dispose of hazardous waste.
- **DO NOT** pour waste oil or fuel directly onto the ground, down a drain or into any water source.
- **NEVER** store saw with fuel in the tank for any extended period of time. Always clean up spilled fuel immediately.

Emergencies

- **ALWAYS** know the location of the nearest **fire extinguisher**.
- **ALWAYS** know the location of the nearest **first aid kit**.
- Know the phone numbers of the nearest **ambulance, doctor** and **fire department**. Ensure that a phone or radio is readily available at the jobsite. If this is not possible, know the location of the nearest phone. This information will be invaluable in the event of an emergency.



Maintenance Safety

- Maintain this equipment in a safe operating condition at all times.
- **ALWAYS** shut down the engine and disconnect battery before performing service or maintenance functions. Contact with moving parts can cause serious injury.
- Securely support any saw components that must be raised.
- **NEVER** lubricate components or attempt service on a running saw.



STOW CS4030 SAW — INTENDED USE / FAMILIARIZATION

Intended Use

Operate the STOW CS4030 SAW, tools and components in accordance with the manufacturer's instructions. Use of any other tools for stated operation is considered contrary to designated use. The risk of such use lies entirely with the user. The manufacturer cannot be held liable for damages as a result of misuse.

This saw is not intended for dry cutting.

Engine

The STOW CS4030 saw is classified in the industry as a "high" powered saw. This classification is particularly useful when selecting the proper cutting tool (blade) for an application.

The STOW CS4030 saw is powered by a liquid cooled, 2 cylinder diesel engine rated at 30 HP (22.37 kW) at 3,000 RPM. Blade rotation is belt driven. Wheel Drive system is driven by a hydrostatic transmission consisting of a variable displacement pump and two fixed displacement wheel motors.

Refer to the *Engine Owner's Manual* for specific instructions regarding engine operation and maintenance practices.

Water System

All STOW CS4030 saws provide a hardy water plumbing system that evenly distributes water volume and optimum flow rate to both sides of the blade to keep it cool when cutting. The basic water system provides a valve that connects to a standard garden hose. The water is delivered (via a hose) to the saw blade.

All STOW CS4030 saws are designed, engineered and manufactured with strict adherence to American National Standards Institute, Inc. (ANSI) guidelines B7.1 and B7.5.

Features

- Tri-Position handlebars allow for 3-position adjustment for optimal maneuverability.
- Engine Stop Switch conveniently located on Operators Control Panel.
- Console mounted with Vibration Control System.
- Chassis cold-formed welded box construction.
- Oil lubricated Blade Shaft Bearings - no lubrication requirements.
- Oil Bath design, fully enclosed cast iron housing.
- Quick Disconnect Blade Flange system; inner flanges mounted to shaft.
- Blade mounting Left side or Right side.
- Saw position guide helps ensure straight cuts
- Dual water lines directly deliver water to blade.
- Slip-On, tapered mount Blade Guard for ease of removal and installation.
- Blade Raise-Lower by electro-hydraulic pump.
- Belt Drive tension automatically controlled by hydraulic tensioning system.
- Dual Filter Element Air Filter with integral turbo pre-cleaner.
- Hydro-gear hydrostatic transmission pump.
- Hydro-gear hydrostatic wheel motors.
- Travel Speed up to 84 MPM (meters per minute)/ 275 FPM.
- Automatic actuating parking brake.
- Easy-Adjust electronically controlled depth stop.
- Optional Night Light.

STOW CS4030 SAW — OPERATION AND SAFETY DECALS

Machine Safety Decals

The STOW CS4030 SAW is equipped with a number of operation and safety decals. These decals are provided for operator safety and maintenance information. Should any of these decals become unreadable, replacements can be obtained from your dealer.

STOW CS4030

P/N 37744



P/N 37515



P/N 36099 (ISO Blue)



P/N 35137

PATENT PENDING

P/N 11912



CONTACT
SERVICE
DEPARTMENT

**DIESEL FUEL
ONLY**

P/N M600002



P/N 23330-001



P/N 36090

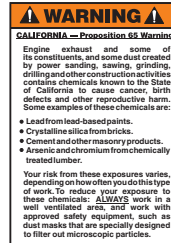

P/N 20525



P/N 36092



P/N 22122-001



P/N 25250-001



P/N 25249-001



P/N 13118



P/N 25491



P/N 25678

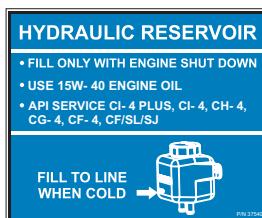

P/N 37540



P/N 21302



P/N 37161

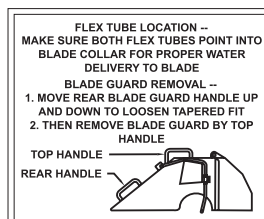

P/N 606004

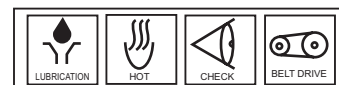

P/N 11246
(Sheet-Intl. Stds)

Figure 3. STOW CS4030 SAW Decals

STOW CS4030 SAW — SERIAL TAG INFORMATION

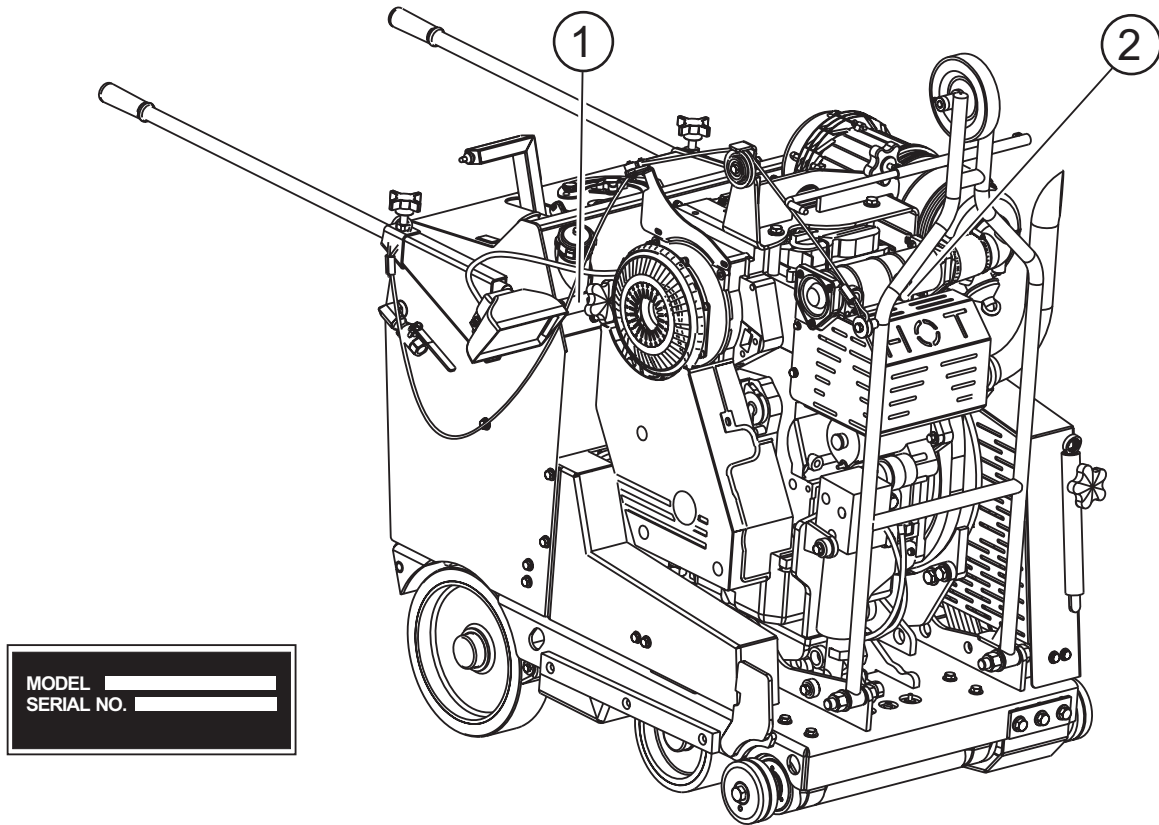

Figure 4. Serial Tag/Locations

Serial Tag

The serial tag contains the model number and serial number of the saw. The information details all parts that were included with the saw when it was shipped from the factory, as well as the date of manufacture.

The **SERIAL TAG** is bonded to the inside of the console. (Item 1, Figure 4.)

Record these numbers, in case you need to contact the manufacturer for information or service in the future.

Record your **ENGINE** model, (Item 2) specification number and serial number here:

Table 6. Serial Tag Information

MODEL NUMBER	SERIAL NUMBER	ENGINE NUMBER

STOW CS4030 SAW — CONTROLS AND INDICATORS

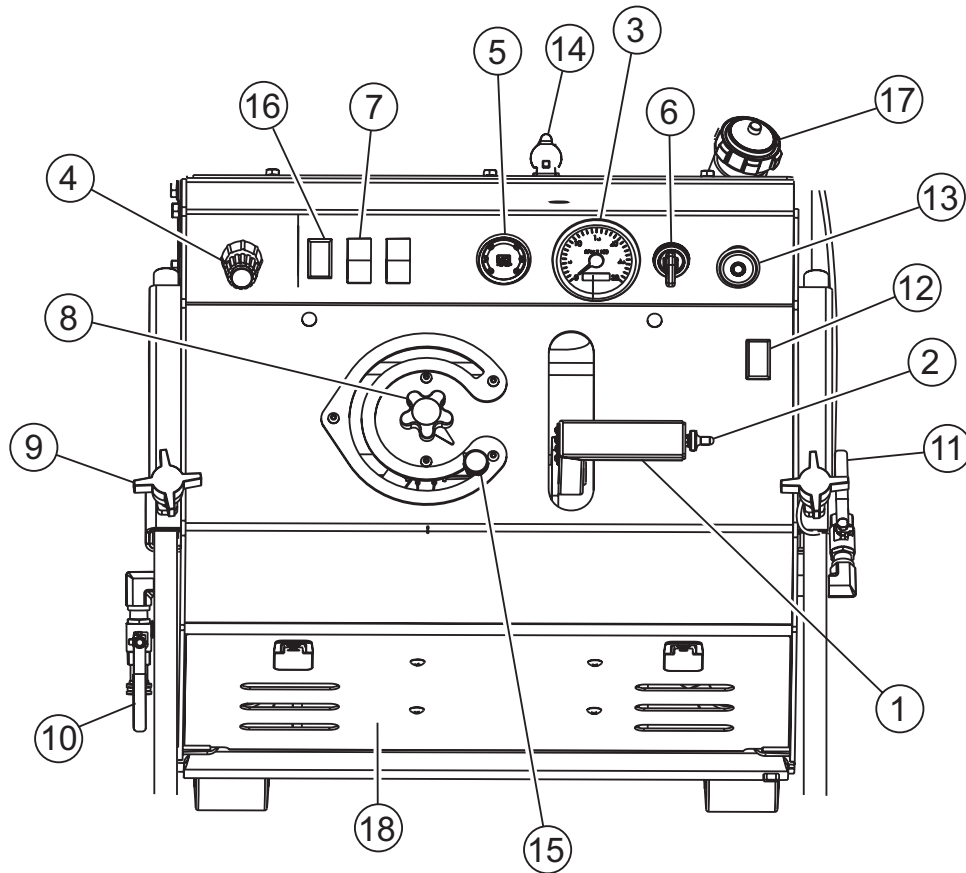

Figure 5. STOW CS4030 SAW Controls and Indicators

Figures 5 and 6 show the location of the controls, indicators and general maintenance parts. The function of each control, indicator or maintenance part is explained below:

1. **FNR Handle** – Use to engage the saw in a forward or backward direction. Push handle forward to move the saw forward; pull handle back to move saw backward.
2. **Raise/Lower Switch** – Use to lift or lower the front of the saw (and blade if installed).
3. **Bladeshaft RPM** – Indicates bladeshaft speed in revolutions per minute.
4. **Throttle Control** – Controls the speed of the engine. Turn knob counter-clockwise to increase engine speed. Turn knob clockwise to reduce engine speed. For quick throttle response, depress red button and push or pull knob.
5. **System Status** – Allows operator to monitor engine and electrical functions.
6. **Ignition Switch** – With key inserted turn clockwise to start engine.
7. **Light Switch** – When activated, turns on light. Lights offer better visibility when working indoors.
8. **Depth Indicator** – Indicates relative depth of blade in surface.
9. **Handlebar Adjust** – Loosen to move handlebar in or out.
10. **Left Water Flow Valve** – Meters water supply.
11. **Right Water Flow Valve** – Opens and closes water supply to water supply system.
12. **Water Pump Switch (Optional)** – Toggle to turn pump on or off.
13. **Emergency Stop Button** – Press the RED Emergency Stop Button to shut the system down.
14. **Socket Connector** – Use to plug in optional light.
15. **Depth Adjustment Knob** – Use to adjust saw blade depth.
16. **Auxiliary Switch** –
17. **Fuel Filler Cap** – Remove this cap to add fuel.
18. **Rear Access Panel** – Remove to access items such as the battery, hydraulic filter, etc.

STOW CS4030 SAW — COMPONENTS

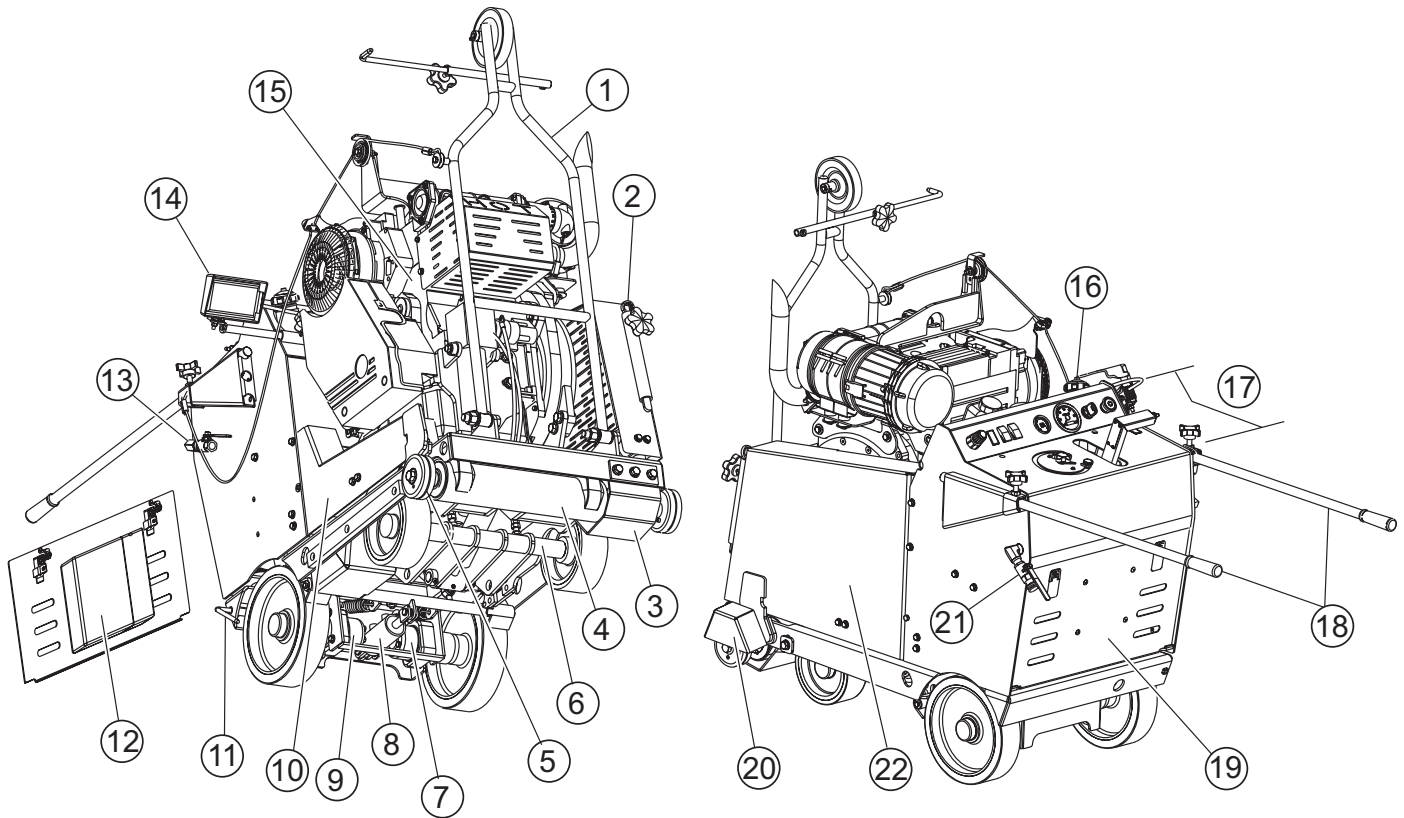

Figure 6. STOW CS4030 SAW Components

- | | |
|----------------------------|--|
| 1. Front Pointer Assembly | 12. Documentation Box |
| 2. Blade Wrench | 13. Rightside Water On/Off Control Valve |
| 3. Bladeshaft Pulley Guard | 14. Light Assembly |
| 4. Bladeshaft Assembly | 15. Engine Assembly |
| 5. Blade Flange | 16. Engine Fuel Filler Cap |
| 6. Front Axle Assembly | 17. Control and Indicator Panel |
| 7. Left Wheel Motor | 18. Handlebars |
| 8. Brake Cylinder | 19. Rear Access Panel |
| 9. Right Wheel Motor | 20. Flange Guard |
| 10. Engine Guard | 21. Leftside Water Metering Valve |
| 11. Rear Pointer | 22. Belt Guard |

STOW CS4030 SAW — BASIC ENGINE INFORMATION

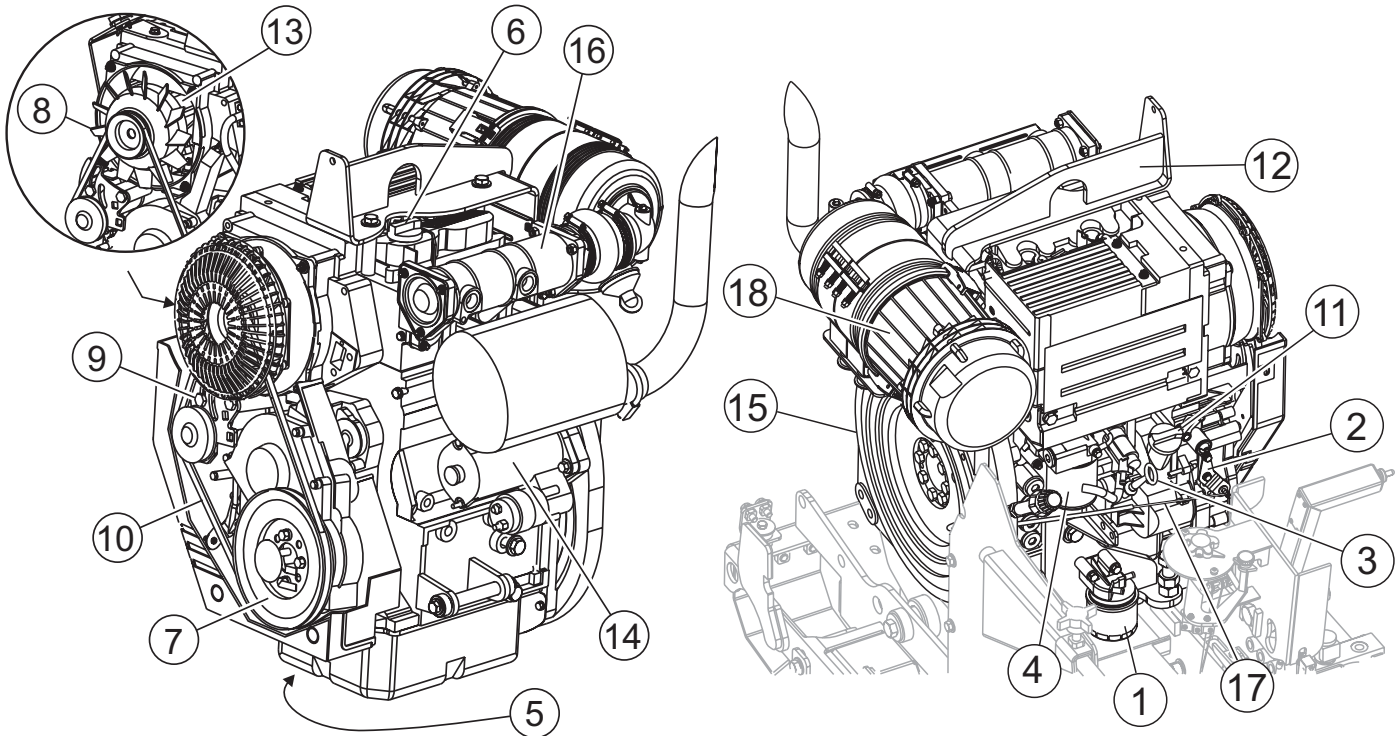

Figure 7. Basic Engine Components

Basic Engine Components

The following refer to basic engine components and their functions that an operator may need to reference. The manufacturer's engine manual provides further instructions and details of operation and servicing. The engine shown in Figure 7 is a **Deutz F2L2011** engine.

1. **Fuel Filter** – Removes dirt and water from the engine fuel.
2. **Governor Lever** – This lever restricts engine speed (high idle and low idle) through a speed control device linked to the accelerator system.
3. **Oil Dip Stick** – Remove to check amount and condition of oil in crankcase.
4. **Oil Filter** – Spin-on type, filters oil for contaminants.
5. **Oil Drain Plug** – Remove plug to drain crankcase oil.
6. **Oil Filler Port** – Remove to add fresh crankcase oil.
7. **Crankshaft V-Pulley** – Check fan V-belt between V-Pulley and fan to determine proper belt tension.
8. **Cooling Fan** – Driven by the V-belt, the cooling fan cools the engine by cooling engine oil that circulates through the engine block and cylinder head.
9. **V-belt Tension Adjustment** – This bolt provides means to adjust the V-belt tension at the alternator bracket.
10. **V-belt (Fan belt)** – Driven by the engine crank during operation, drives the fan as well as the alternator.
11. **Oil Fill Cap** – Remove to add engine oil.
12. **Lifting Eye** – The lifting eye is provided if the removal/installation of the engine becomes necessary.
13. **Alternator** – Located inside the fan assembly. Provides current to the electrical system and charges the battery. Driven by means of a crankshaft/V-belt pulley system.
14. **Starter** – Starts engine when ignition key is rotated to the "START" position.
15. **Flywheel** – Main power is taken off from the flywheel end.
16. **Air Intake Port** – Provides air from the air cleaner to the turbocharger unit.
17. **Throttle Cable** – Provides direct control of engine throttle lever from throttle control located on the console control panel.
18. **Air Cleaner Assembly** – Provides clean filtered air to the air intake port.

STOW CS4030 SAW — CHOOSING PROPER BLADE SIZE

Choosing Proper Blade Size

To select the proper size blade for the job requires an understanding of the cutting capability of your saw and its relationship between engine power, (as reflected in the engine RPM), and the speed (RPM) of the Blade Shaft. The diesel engine of the STOW CS4030 runs at 2800 RPM (full load). If 2800 RPM was a desirable Blade Shaft speed for the average conditions in which you work, we would use the same size sheave on the engine shaft and the blade shaft making the resulting ratio between the two of 1:1. (See figure 8.)

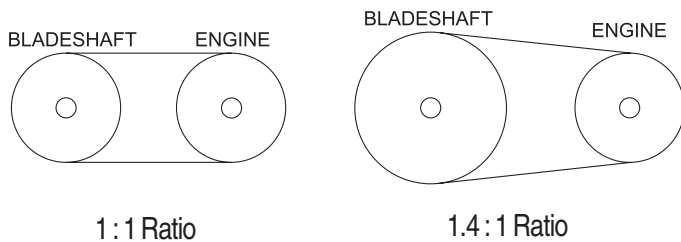

Figure 8. Blade Shaft Ratios

If, however, for your cutting conditions, you need a Blade Shaft speed slower than the engine speed (and this usually is the case), we then need to INCREASE the ratio between the two speeds by using a larger diameter sheave on the Blade Shaft, which will cause the Blade Shaft to run slower than the engine speed. If, for example, you know from experience that you need a Blade Shaft speed of 2000 RPM for the size of blade you normally use, divide the engine speed RPM by the desired blade speed RPM (refer to the Blade RPM vs. SFPM Chart, Table 7.)

$$2800 \text{ (engine RPM)} / 2000 \text{ (desired BS RPM)} = 1.4$$

This is the ratio 1.4 : 1, which means that for every 1.4 revolutions of the engine, the Blade Shaft only turns once.

Ratios greater than 1 : 1 also have the beneficial effect of *increasing the torque of the Blade Shaft* by the same factor (1.4 in our example). The manufacturer advertises the Deutz 2011 Series diesel engine develops 133 ft. lbs. (max) of torque. To find the *theoretical* Blade Shaft torque of our example saw setup:

$$133 \times 1.4 = 186.2 \text{ ft. lbs.}$$

Actual torque of the saw will vary somewhat. In general, more torque means more cutting power.

Typically, however, the ratios are not used to design a level of torque; they are used to create optimum blade speed (Blade Shaft RPM) for your application.

The major factors are:

- diameter of blade(s) you commonly use
- cutting conditions

STOW CS4030 SAW — CHOOSING PROPER BLADE SIZE

Blade RPM vs. Surface Feet Per Minute (SFPM)

When choosing a blade for your cutting conditions, follow the blade manufacturer's recommendations. Match the blade speed (Blade Shaft RPM) to the recommended blade Surface Feet Per Minute (SFPM) See table 7.

CAUTION

Verify the engine start switch is **OFF** before removing or installing a blade.

Tighten the 5/8" blade-mounting bolt to 125-175 ft. lbs. of torque.

WARNING

Maximum allowable Blade Surface Feet Per Minute per ANSI Standard B.7.1 is 16,000 SFPM.

Table 7. Optimum Blade RPM Range

BLADE / ENGINE SPEEDS		Blade Size			
		16	20	26	30
Blade Shaft	Flange Size	4.5	4.5	4.5	5.0
	RPM	2900	2500	2000	1800
	Pulley Size	3.60	4.20	4.20	4.75
Engine	RPM	2800	2800	2800	2800
	Pulley Size	3.70	3.70	3.03	3.03

STOW CS4030 SAW — SPECIFIC TOOLS / SAW BLADES

SPECIFIC TOOLS TO BE USED

This saw is to use tools (blades) as follows:

Steel Core Segmented or Continuous Diamond Rim Cutting Wheel.

Any other type of tool is not to be used.

WARNING

Failure to thoroughly inspect the diamond blade, (Figure 9) for operational safety could result in damage to the blade or the saw, and may cause injury to the user or others in the operating area. Discard damaged or worn blades and replace with fresh blade.

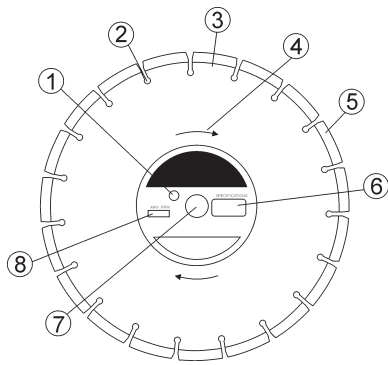

Figure 9. Diamond Blade

1. **Drive Pin Hole** – A commonly located hole on the diamond blade core that prevents operational blade slippage between the inner & outer blade flanges (collars). Inspect the diameter of the hole to ensure there is no distortion, and that a snug fit develops between the hole and drive pin.
2. **Stress Relief Holes (Gullets)** – Check the steel core for cracks that may have propagated from the slots and/or gullets. Cracks indicate extreme fatigue failure and if sawing continues, catastrophic failure will occur.
3. **Edge Of The Steel Core** – Check the diameter edge for discoloration (blue oxidation) indicating an overheating condition caused by insufficient cooling water/air. Overheating of blades may lead to loss of core tension and/or increase the possibility for blade failure. Check to make sure the steel core's width is uniform about the rim of the blade, and not succumbing to an "under cutting" condition brought about by highly abrasive material or improper under cutting core protection.
4. **Directional Arrow** – Check to ensure that the blade is oriented properly on the spindle for sawing. Reference the directional arrow on the blade and place it so the direction of rotation "downcuts" with the turn of the shaft.
5. **Diamond Segment or Rim** – Ensure there are no cracks, dings, or missing portions of the diamond segment/rim. **DO NOT use a blade that is missing a segment or a portion of the rim.** Damaged and/or missing segments/rims may cause damage to your saw, and injury to the user or others in the operating area.
6. **Specifications** – Ensure that the blade specifications, size, and diameter properly match up to the sawing operation. Wet blades must have water to act as a coolant. Utilizing a diamond blade not matched properly to the task may result in poor performance and/or blade damage.
7. **Arbor Hole** – It is essential that the arbor hole diameter properly matches the shaft arbor, and that it is free from distortions. Correct blade flanges (collars) must be used. The inside face of the flanges must be clean & free of debris. An out of round arbor condition will cause damage to the blade and the saw.
8. **MAX RPM** – This RPM reference is the maximum safe operating speed for the blade selected. **NEVER** exceed the max RPM on the diamond blade. Exceeding the MAX RPM is dangerous, and may cause poor performance and may damage the blade. All blades used must be designed for the maximum spindle RPM.

STOW CS4030 SAW — INSTALLING THE BLADE

Installing the Blade

The blade can be mounted on either side of the saw to accommodate different cutting jobs. With the proper sized blade selected, install the new blade referring to the following procedure.

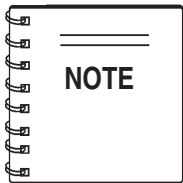

Ensure the flange faces are kept clean and smooth as well as the inside diameter of the Blade Shaft.

1. Raise the saw so the blade will clear the ground when installed.
2. Remove the blade flange bolt. This bolt is **LEFT-HAND** thread on the **RIGHT** side of the saw and **RIGHT-HAND** thread on the **LEFT** side of the saw.
3. Verify the blade flanges are clean and not damaged. Pay particular attention to all holes and recesses. (Figure 10.)

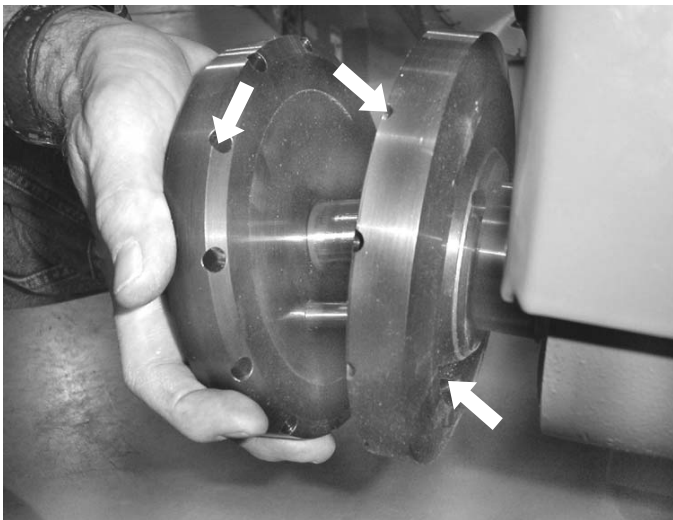

**Figure 10. Inspect and Clean Flange
(Optional Blade Flange System shown)**

3. Taking note of the direction of rotation of the blade, (Item A, Figure 12) insert the bushing and mounting bolt through the outer flange and blade. (See Figure 11.)
4. Align flange pin through the blade into the inner flange.

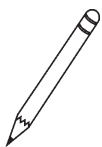
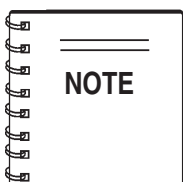

The Blade Mounting Bolt on the right side of the saw (as viewed from the operator's position), has a *Left-hand* thread, while the bolt on the left side of the saw has a *Right-hand* thread.

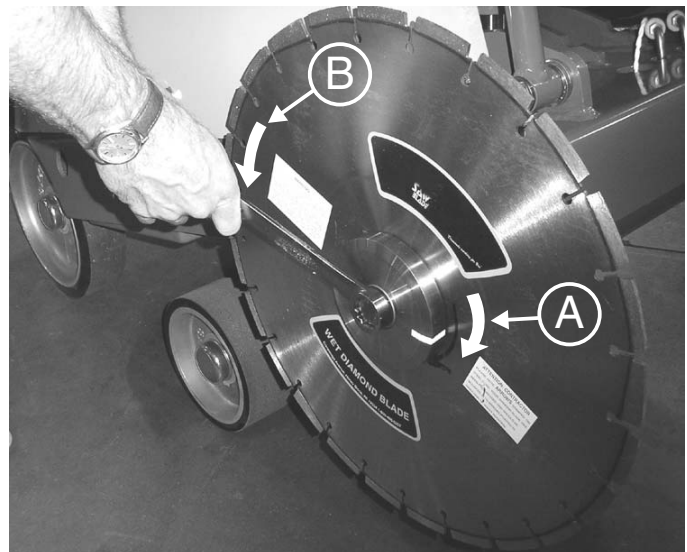

**Figure 11. Aligning Flange Pin Through Blade
(Standard Blade Flange System shown)**

WARNING

Failure to properly tighten the Blade Mounting Bolt can result in the bolts coming loose with the Blade Flange potentially falling off the rotating Blade Shaft Assembly. The Blade and other parts coming loose from the saw during operation pose a high risk of serious injury or even death!

5. With the Blade still off the ground, tighten mounting bolt as tight as can be achieved until blade spins. (Item B, Figure 12 shows tightening direction for blade mounted on **RIGHT** side of saw.)



- A. **Blade Direction of Rotation**
- B. **Tightening Direction - Right Side**

Figure 12. Blade Rotation Direction

STOW CS4030 SAW — INSTALLING THE BLADE

CAUTION

An improperly torqued Mounting Bolt can cause the inside diameter of the Blade, Blade Shaft, and Flange Bushing to quickly wear. This can result in poor cutting characteristics or premature failure of these parts requiring replacement and machine "downtime".

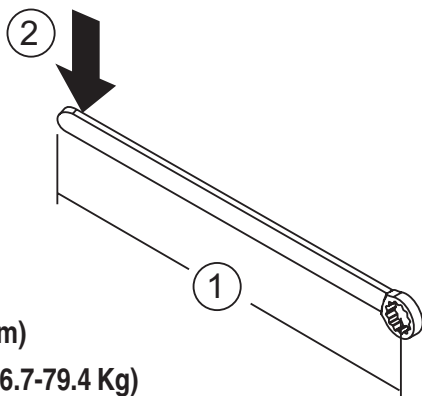

1. 12 In. (30.48 cm)
2. 125-175 lbs (56.7-79.4 Kg)

Figure 13. Blade Wrench

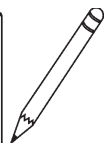
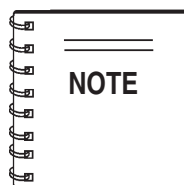

125-175 lbs. (56.7-79.4 Kg) of weight applied to the end of the blade wrench will provide 125-175 ft. lbs. (169.5 - 237.3 Nm) of torque to the blade mounting bolt. (Figure 13.)

6. Lower the blade to the ground surface (A in Figure 14) to prevent blade from spinning and tighten the mounting bolt to 125-175 ft. lbs. (169.5 - 237.3 Nm) of torque. (Item B in Figure 14.)

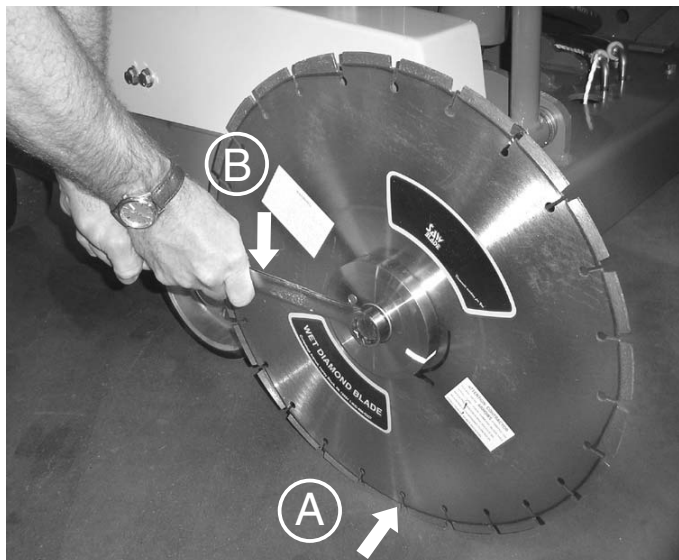

Figure 14. Torque Flange Bolt

Stacking Blades for Wide Cuts

Combining, or stacking blades together to make wide cuts requires an optional Bushing Extension Kit.

WARNING

NEVER attempt to stack blades beyond the capacity of the kits described here. **NEVER** operate the saw without blade guards in place.

- Kit #18501 allows blade stacking from .375" to .75" thickness.
- Kit #18502 allows blade stacking from .75" to 1.125" thickness.

1. Remove existing blade. (See previous section.)
2. Replace the standard Flange Bushing, Outer Flange, and Mounting Bolt that came with the saw, with the extended Bolt and Bushing and the new Outer Flange supplied with the kit. Remember that the Mounting Bolt for the right side of the saw has a left-hand thread while the Mounting Bolt for the left side of the saw has a right-hand thread.
3. Insert the Bushing and Mounting Bolt through the Outer Flange and stack of Blades. Spacers are required between blades when stacking multiple blades. The longer bushing and bolt allow blades to be stacked together while maintaining proper alignment of Flange Bushing into Blade Shaft.
4. Align Flange Pin through the stack of blades into the Inner Flange.
5. Tighten the 5/8" Mounting Bolt to 125-175 ft. lbs. of torque.

STOW CS4030 SAW — BLADE GUARDS

Blade Guard

The Blade Guards can be mounted on either side of the saw to accommodate different cutting jobs.

Removing a Blade Guard:

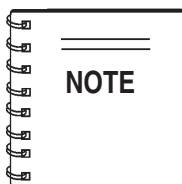

The saw utilizes a tapered Blade Guard mounting clip that, during operation, settles in the taper by the weight of the guard locking itself into place providing a rigid, rattle-free fit.

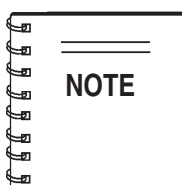

Blade Guards 36" or larger are equipped with a removable hinge pin which allows the front half of the Blade Guard to be easily removed. The rear half then is removed by sliding it toward the back rather than upward. Installation is a reverse of this process.

1. Remove the water delivery hose from the Blade Guard. (See Figure 15.)



Figure 15. Blade Guard Water Delivery Connector

2. Standing toward the back of the blade guard, grasp the top handle firmly with your outboard hand (this will be the right hand if the guard is mounted on the right as viewed from the operator's position), and prepare to support the weight of the blade guard. (Figure 16.)
3. With the opposite hand grasp the rear handle and rock back and forth with an upward pressure to release the Blade Guard tapered mounting clip. (See NOTE above for Blade Guards 36" or larger.) Lift straight up then pull back once the tapered lock is released. Install Blade Guard in reverse order.



Figure 16. Removing The Blade Guard

Installing a Blade Guard:



NEVER operate the saw with the front half of the Blade Guard removed.

STOW CS4030 SAW — BLADE GUARDS

Blade Guards 30" and Smaller:

1. Slide the Blade Guard straight downward to engage the tapered Mounting Clip. (See Figure 17.)

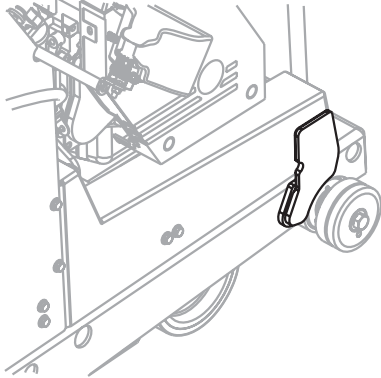

Figure 17. Tapered Mounting Clip

2. Connect the water delivery hose to the Blade Guard. (Figure 15.) Ensure that the water hoses are pointed toward the water distribution grooves in the Blade Flanges. (Figure 18.)



Figure 18. Water Hose Detail

3. Ensure the front hinged section of the Blade Guard is fully closed before use.

STOW CS4030 SAW — WATER DELIVERY SYSTEMS

Installing the Flange Guard

The Flange Guard protects the Blade Flange not in use.

1. Slide the Flange Guard onto the Guard Mounting Tab on the frame. (See Figure 19.)
2. Verify that the Blade Flange not in use is secured to the Blade Shaft, by tightening the mounting bolt.

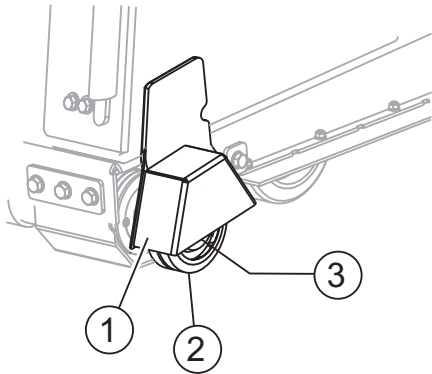

Figure 19. The Flange Guard Installed



Figure 20. Optional Blade Guard Water Tube

Water Delivery System (Option)

CAUTION

When storing the saw where temperatures may drop below freezing, blow out the water lines to prevent damage to the water delivery system.

1. Connect the water supply hose to the water inlet (garden hose) fitting on the left side of the saw, (Item 20, Figure 4).
2. Verify that the water hose on the saw is connected to the Blade Guard, (Figure 15), and that the water hoses or tubes are pointed into both Blade Flanges.

Ensure that the hose ends maintain a 45° angle and maintain a light contact with the surface of the blade.

3. Ensure that the hose ends maintain a 45° angle and maintain a light contact with the surface of the blade. (Figure 18.)

5. The lever on the left side of the control panel regulates water flow volume. The lever on the right side of the control panel turns the water ON and OFF.
6. If the saw is equipped with an optional water pump, the ON/OFF switch is located on the control panel next to the water ON/OFF control valve.

Battery Setup

WARNING

Flammable, explosive gas. (produces hydrogen gas while charging or during operation). Keep area around battery well ventilated and keep from any fire source.



Battery electrolyte contains corrosive, toxic chemical. (dilute sulfuric acid). Avoid contact with eyes and skin.

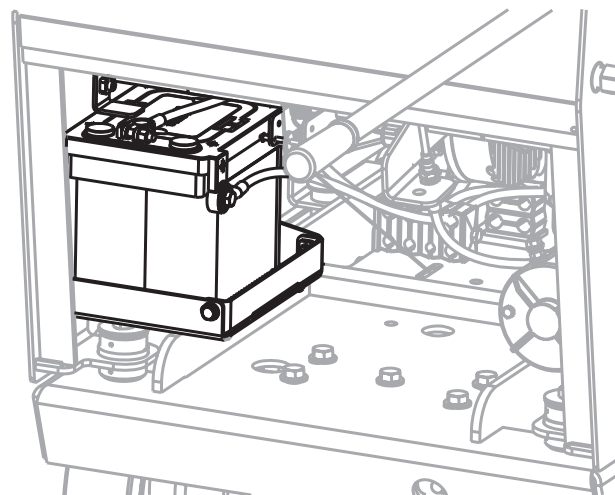

Figure 21. Battery and Battery Box

WARNING

Shock or Fire due to electric short-circuit. Disconnect battery cables before inspecting electrical system and never "spark" battery terminals to test for charge.



To install the battery on the saw, make sure that the battery is properly clamped into the battery box. Connect the positive cable to the positive terminal on the battery first, then connect the negative cable to the negative terminal.

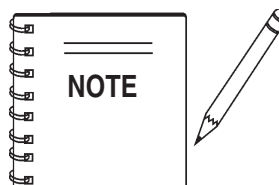

The STOW CS4030 Saw uses 2 positive battery cables and 2 negative battery cables. One set is for the starter on the engine and the other set is for the raise/lower pump assembly. Make sure that both sets of cables are connected to the battery.

CAUTION

Use all safety precautions specified by the battery manufacturer when working with the battery. See further specific safety information on page 18 of this manual.

This saw was shipped with a wet charged battery, (Figure 21). This battery may need to be charged for a brief period of time as per the manufacturer instructions.

STOW CS4030 SAW — FUELING THE SAW

Fueling the Saw

This saw features an 8 gallon, clear, molded plastic fuel tank for ease of checking the fuel level. It has a central drain and a shutoff valve. The fuel tank cap is located at the front of the control panel console and a fuel gauge tube is featured on the front of the console.

CAUTION

Handle fuel safely.

Motor fuels are highly flammable and can be dangerous if mishandled.

DO NOT smoke while refueling.

DO NOT attempt to refuel the saw if the engine is hot or running.

Avoid spilling fuel on the control panel or engine. Clean up fuel spills to avoid falls from slipping.

DO NOT overtighten the fuel tank cap.



WARNING

Use **DIESEL FUEL ONLY**.

NEVER use gasoline or fuels not specifically for use in the Deutz Diesel engine.

1. Determine if the engine fuel is low. (Figure 22)
2. If fuel level is low, remove the fuel filler cap and fill with diesel fuel. (Cetane fuel number 45 or greater).

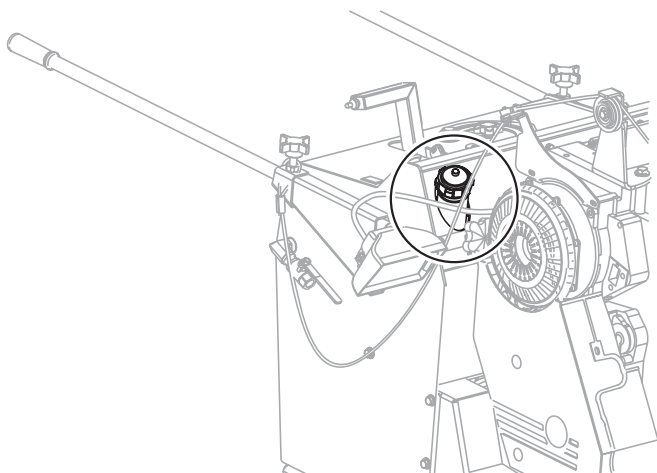

Figure 22. Fuel Gauge

Priming the Fuel System

The saw utilizes a fuel primer bulb (A) or button (B) Figure 23, when fueling the saw for the first time or re-filling after running out of fuel.

Primer Bulb Systems: Locate the fuel primer bulb inside the console beneath the fuel tank, (A) Figure 23, and squeeze the fuel priming bulb until it fills with fuel, (it will become firm when properly primed), priming the fuel transfer pump.

Primer Button Systems: Locate primer button (B) in Figure 23 and simply press button to prime the system.

WARNING

DO NOT crank the engine without fuel in the line between the tank and the primary fuel pump to prevent damage to the primary fuel transfer pump.

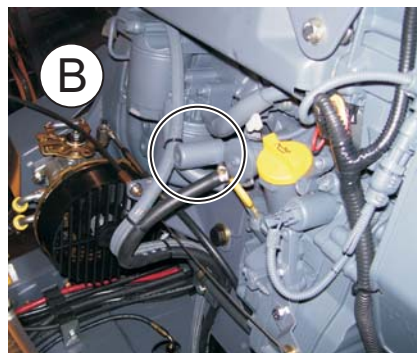
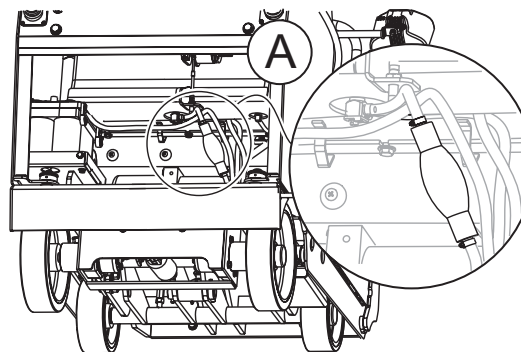

Figure 23. Fuel Primer Bulb (A) or Button (B)

Storage With Fuel In System

CAUTION

DO NOT store with fuel in the tank for an extended period of time. Completely drain fuel system (tank, lines, etc.) if the unit is to be put into long term storage. For shorter or intermediate periods of time the tank should be filled to avoid condensation that could cause contamination of the fuel.

STOW CS4030 SAW — POINTER ADJUSTMENT

Cold Weather Operation

Glow Plugs

In weather where temperatures reach below 30° fahrenheit/ 0° Celsius, Glow Plugs may be required to start engine.

To start engine using assistance of Glow Plugs, turn Ignition Switch to ON position and monitor Glow Plug Indicator Light on System Status Indicator, (Figure 24). When Glow Plug Light goes out, rotate Ignition Switch to the START position. Release key when engine starts.

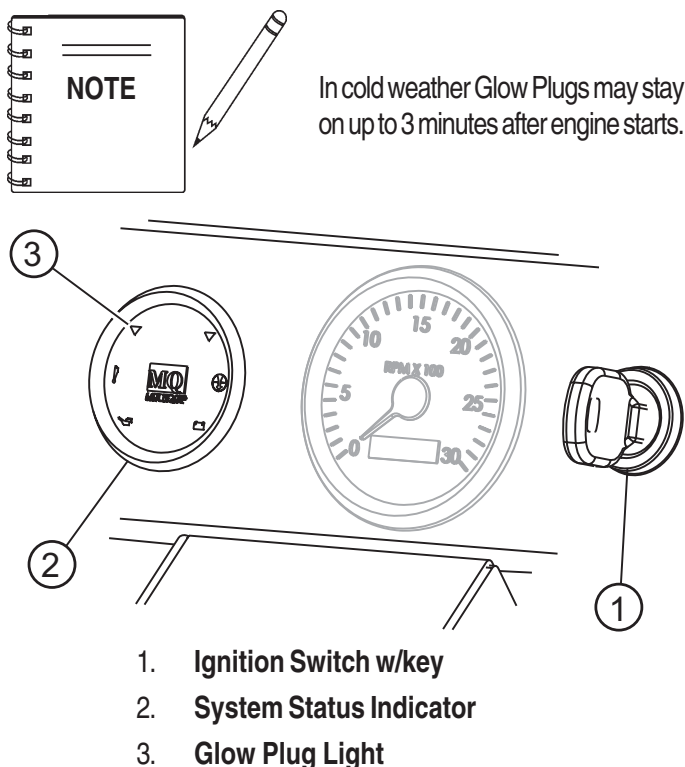

Figure 24. Ignition Switch and System Status

Block Heaters

CAUTION

DO NOT leave optional Block Heaters plugged in for extended periods when temperatures may rise above 20°F, (-6.67° Celsius). The oil could "cook" inside the crankcase and damage to the engine could result.

If the water system is not drained when the saw is not in use and temperatures fall below 32° F, (0° C), damage may occur to optional water pumps.

In extreme cold weather, optional Block Heaters may be used. Block Heaters are installed directly onto the crankcase and are operated by plugging into a 110VAC electrical outlet. Be sure to use appropriate gauge wire when using extension cords and abide by all safety rules when using electrical power, power cords, and extension cords. Do not use Block Heaters when the when temperatures are above 20° F, (-6.67° Celsius).

Draining the Water System

When low temperatures fall below 32° F, (0° C):

1. If the saw is equipped with an optional Water Pump, open the drain petcock on the pump and allow the pump to drain. Turn the water pump switch on for a few seconds to purge any water remaining inside the pump body.
2. Tilt the saw UP and BACK, to allow water to drain.
3. Tilt the saw FORWARD, to allow water to drain again.
4. If an air compressor is available, blow out the system by applying compressed air to the Water Inlet.

Pointer Adjustment

1. Lower the front pointer assembly, (Figure 25).

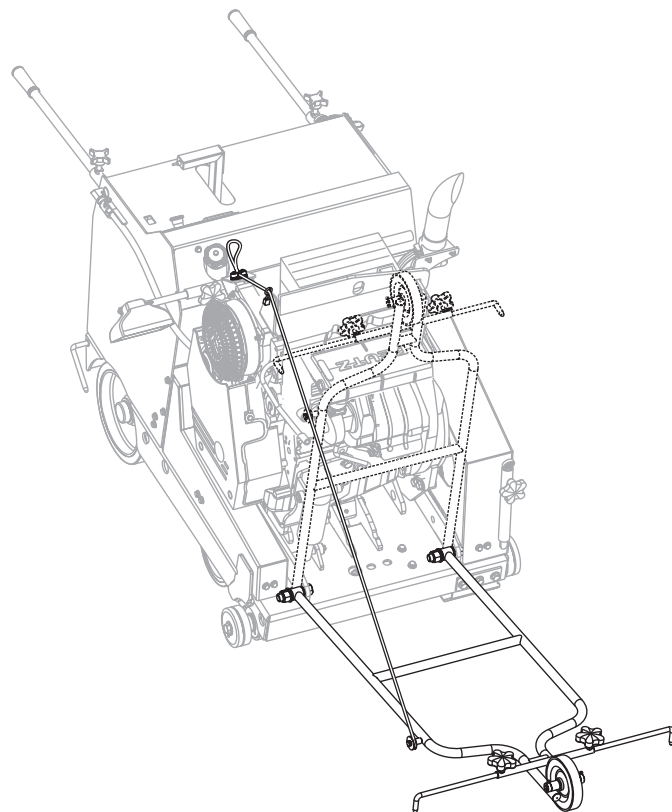

Figure 25. Pointer Assembly

STOW CS4030 SAW — RAISE-LOWER CONTROLS

- Using 10-12 ft. (3-3.7 meters) of stringline, divide the length of the string in half and slide the string into one of the slots or gullets on the backside of the blade, (as viewed standing in front of the pointer). (Item 2, Figure 26) Hold both ends of the string in one hand and pull the string taut. (Item 3) Move your hand from side to side until both strings are touching both sides of the blade.
- Adjust the pointer rod (Item 5), by loosening the lock knob (Item 4). Move the pointer directly over the middle of the two strings in your hand and tighten the pointer setscrew to lock the pointer in position. Repeat this process for the rear pointer.
- To raise the front pointer assembly, (Item 1) first pull back and up on the pointer cable. Secure the pointer assembly in the desired raised position by locking the cable between the jaws of the cam cleat.

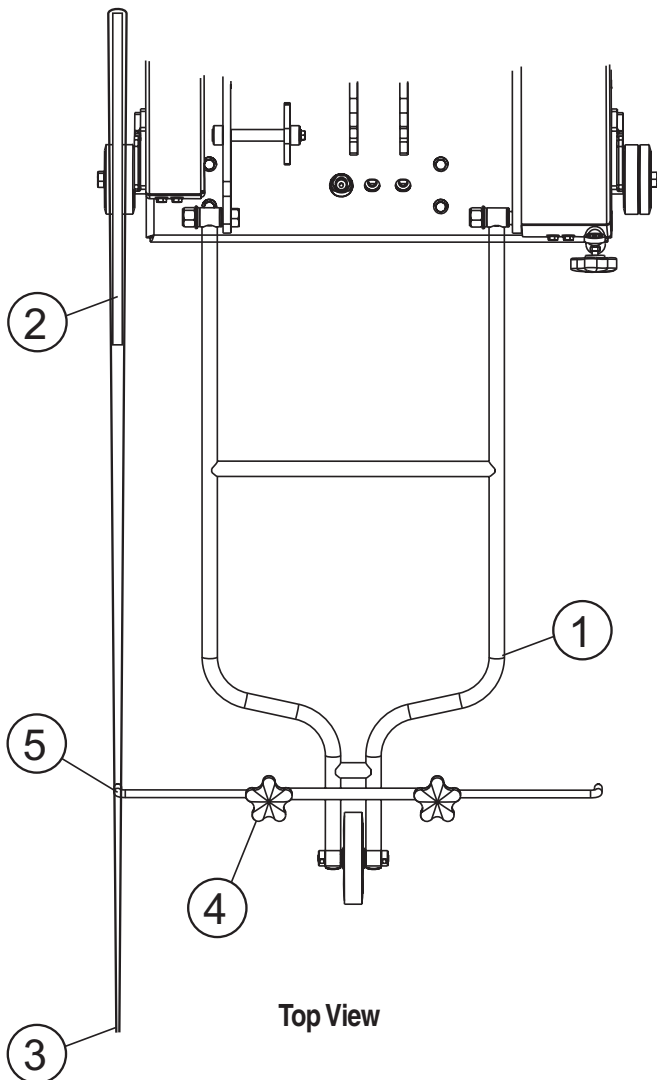

Figure 26. Adjusting the Pointer Assembly

Raise - Lower Controls

The STOW CS4030 saw uses a 12-volt hydraulic pump and cylinder to raise and lower the saw. The raise-lower function is controlled by the operator through a 3-position toggle switch on the raise-lower control handle located on the operators control panel.

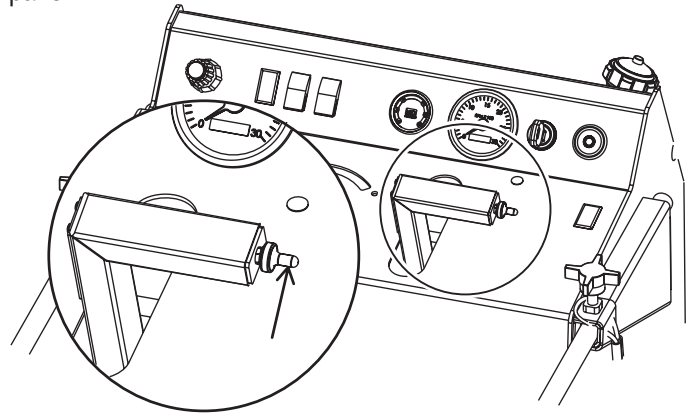

Figure 27. Raise-Lower Control Toggle Switch

- To Lower the blade, push the toggle switch located on the end of the Control Handle FORWARD, (Figure 27).
- To Raise the blade, pull the toggle switch located on the end of the Control Handle BACKWARD.

Setting the Depth Indicator

- Lower the blade until it just touches the cutting surface.
- Set the Depth Indicator dial to zero. (The Depth Indicator now accurately indicates how deep the blade is cutting.) (Figure 28)

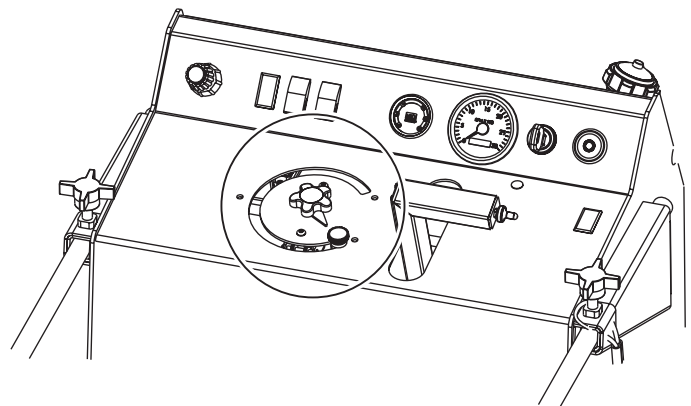

Figure 28. Depth Indicator

STOW CS4030 SAW — BLADESHAFT ENGAGE SYSTEM

Setting the Depth Stop

The CS4030 saw uses a controlled Depth Stop to position and set the blade at a desired cut depth. (Figure 29.)

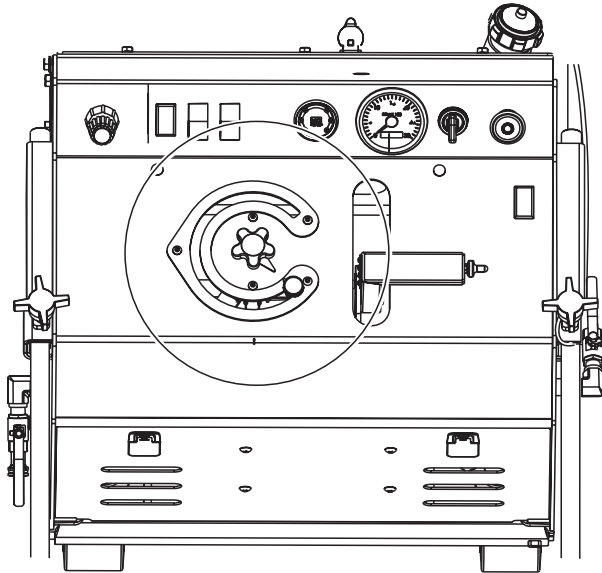
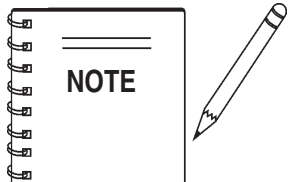

Figure 29. Depth Stop



If a blade is changed for any reason, or if wear is suspected since the last time depth stop was set, you will need to re-set the depth stop. If a cut at a precise depth is necessary, it is best to make a pre-cut and MEASURE at deepest part of cut to confirm cut is at desired depth.

To Control the Depth of Cut with saw running and Blade Mounted:

1. Set Depth Indicator as outlined on previous page.
2. Loosen pointer knob, (Item 1, Figure 30).
3. Rotate pointer to desired depth, (Item 2, Figure 30).
4. Re-tighten pointer knob to lock-in cutting depth.

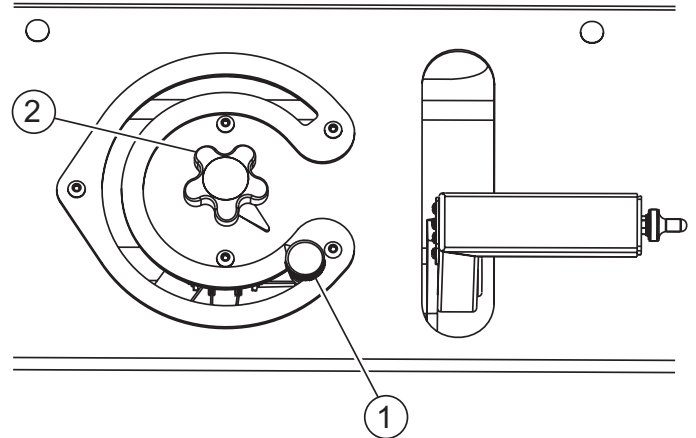

1. Depth Control Knob
2. Depth Indicator Pointer

Figure 30. Indicator and Depth Control Knob

WARNING

Always adhere to manufacturer's blade speed recommendations for Surface Feet Per Minute when choosing a blade for your cutting conditions. See blade size/speed information, "Blade RPM vs. Surface Feet Per Minute (SFPM) on page 24.

STOW CS4030 SAW — OPERATION

Wheel Drive System

The STOW CS4030 saw features a cable-controlled hydrostatic transmission with infinite Forward-Neutral-Reverse (F-N-R) speed adjustment. This is controlled by the operation through the control handle located on the operator control panel. The saw is designed with locked axle drive, and can travel at speeds up to 275 feet per minute.

A bi-directional variable displacement transmission pump powers two hydraulic wheel motors that are directly coupled to the wheels. The hydrostatic transmission provides vehicle propulsion in both forward and reverse depending on the position and direction of movement of the F-N-R control handle. The hydrostatic transmission also provides dynamic braking action.

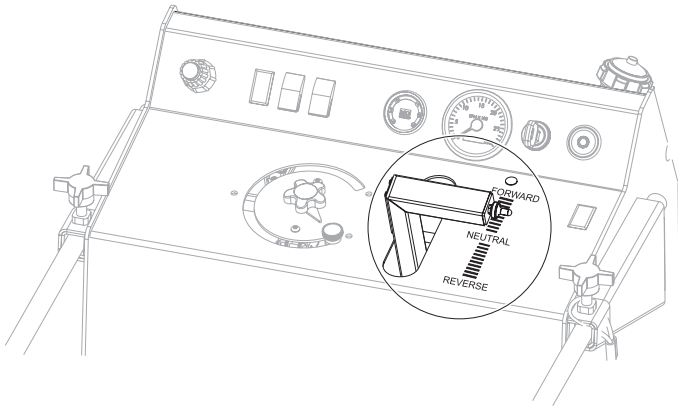

Figure 31. F-N-R Control

Refer to Figure 31.

- To increase the forward speed, slowly move the control handle FORWARD.
- To decrease the forward speed, pull the control handle BACKWARD.
- When the control handle is in the Neutral position the saw will have neither a forward nor reverse motion.
- As the control handle is passed backward through the neutral position the saw will start to move in REVERSE. Reverse speed is also controlled by the position of the control handle.

STARTING AND STOPPING THE ENGINE

! WARNING

DO NOT leave the saw unattended while the engine is running. **NEVER** start, park, or leave the saw unattended on a slope.

! CAUTION

Allow the engine to warm up before increasing engine speed.

DO NOT stop the engine abruptly when hot. Reduce the throttle to idle and allow the engine to run one or two minutes before turning the ignition switch off. This allows the engine to cool down preventing damage to the Turbo charger.

Starting the Engine

1. Move the speed control handle to the NEUTRAL position.
2. Set the throttle to IDLE.
3. Make sure the Emergency Stop Button is in the OUT position.
4. Ensure that water lines are attached and water is flowing to the saw blade.
5. Turn the Ignition Switch to the ON position. (Figure 32.)

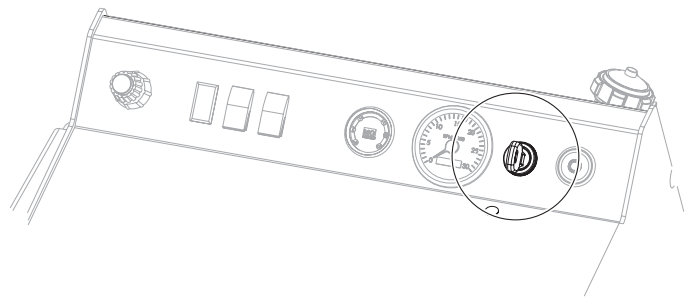

Figure 32. ON/OFF Switch

6. Wait for the Glow Plug Indicator Light to go out.
7. Turn Ignition Switch to the START position; RELEASE switch after engine starts.

STOW CS4030 SAW — OPERATION

8. Allow the engine to warm up for several minutes.
9. Set the throttle to the recommended engine RPM to match the recommended blade speed of the attached blade.
10. Lower the blade to the cut depth.
11. Move the control handle FORWARD to advance the cut.

Stopping the Engine

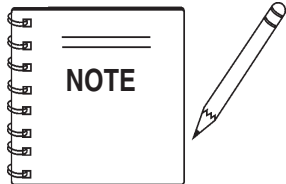

In case of an EMERGENCY, push the RED EMERGENCY-STOP BUTTON to stop all functions. (Figure 33.) Engine will not crank when emergency stop button is depressed.

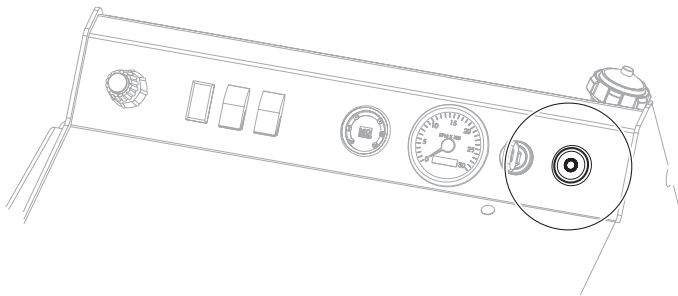

Figure 33. Emergency Stop Button

1. When finished with the cut, move the control handle to the NEUTRAL position.
2. Raise the saw blade out of the cut.
3. Reduce the throttle to idle.
4. Allow the engine to run one or two minutes to let the engine cool down.
5. To stop the engine, turn the Ignition Switch to the OFF position.

Restarting After Running Out of Fuel

The 2011 series Deutz engines do not require bleeding of the fuel system if the engine is run out of fuel.

To restart the engine:

1. Re-fill the fuel tank with fresh, clean diesel fuel.
2. Re-prime the fuel system by squeezing the fuel prime bulb (located inside the console, directly under the fuel tank), until the fuel primer bulb will becomes firm.
3. Crank the engine normally until it starts.

Operating Synopsis

BEFORE STARTING – Check all fluid levels. Secure blade firmly to bladeshaft. Make sure all protective guards are in place and properly mounted. Wear eye, ear protection and protective clothing.

WATER SUPPLY – Connect water supply to water inlet. Move water ON/OFF CONTROL to ON position. Adjust WATER FLOW CONTROL lever to desired position. Drain watering system in cold weather to prevent damage due to freezing.

BLADES – Always follow blade manufacturer's recommendations for blade selection, speed and application. NEVER exceed blade manufacturer's maximum rated RPM. See previous steps for detailed blade mounting instructions.

STARTING ENGINE – Set CONTROL HANDLE to NEUTRAL position. Set THROTTLE to IDLE. Turn start switch to ON position. Wait for glow plug indicator light to go out. Momentarily turn switch to start position; release switch as soon as engine starts. Allow engine to warm up for several minutes before increasing engine speed. Use approved diesel fuel only.

STOPPING ENGINE – Do not stop engine abruptly when hot! Reduce THROTTLE to IDLE and allow engine to run 1 to 2 minutes before turning ignition switch off. Damage to engine may occur if not allowed to cool adequately.

FWD-NEUTRAL-REV CONTROL – The panel mounted handle controls FORWARD, NEUTRAL AND REVERSE operation. Neutral position stops or holds saw in a stationary position. Incremental movement in the FORWARD or REVERSE direction will increase speed proportionate to amount of movement.

RAISE-LOWER FUNCTION – RAISE-LOWER function is controlled by the switch mounted at the right side of the CONTROL HANDLE. Push toggle switch lever forward to lower saw. Pull toggle switch lever backward to raise saw.

BRAKES – This saw is equipped with parking brakes. Brakes are applied automatically when engine is off and dis-engaged when engine is running.

STOW CS4030 SAW — LOADING AND TRANSPORTING

LOADING/UNLOADING AND TRANSPORTING THE SAW

Loading and Unloading

! WARNING

When **LOADING, UNLOADING**, or when on a **STEEP SLOPE**, the engine **MUST BE** at 1800 RPM or above to prevent loss of control.

Tie-Down Points

The saw is provided with holes at each corner of the lower frame for easy tie-down during transportation.

! CAUTION

NEVER tie the back end of the saw down by strapping across the handlebars.

! CAUTION

The use of tie-downs to secure the saw during transportation is highly recommended. **ALWAYS** secure the saw during transportation to prevent unwanted movement or shifting that could result in equipment damage or injury to personnel.

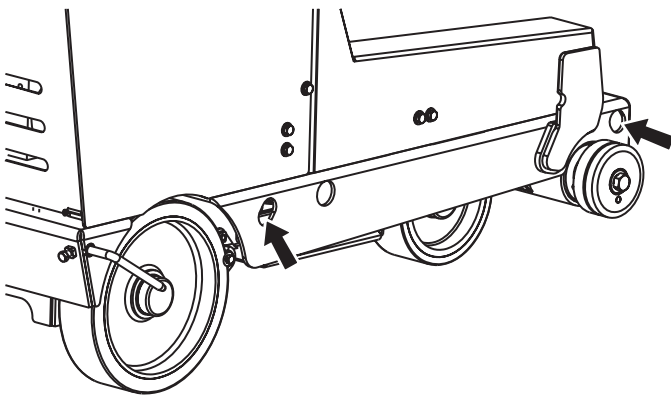

Figure 34. Tie-Down Points

Lifting Point

The convenient single point for lifting the saw with a hoist is located above the engine. (Figure 35.)

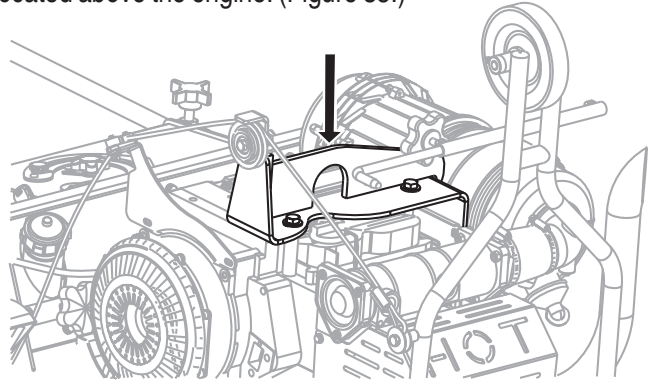

Figure 35. Lifting Point

! WARNING

AVOID INJURY!

Stay clear of the saw while it is being hoisted.

To avoid possible damage to the saw, use approved rigging (minimum 3000 lb. test) when hoisting the saw.

Night Light

The night light, (Figure 36), can be used on either side of the saw and can be extended and rotated for best illumination of the cutting area. Aim the light then lock it in position by tightening the lock knobs. The light can be removed for storage by loosening the lock knobs, disconnecting the light cord and sliding the light bar out of the saw.

To turn Lights ON, push the rocker-style switch located on the instrument panel forward. To turn Lights OFF, push rocker switch backward.

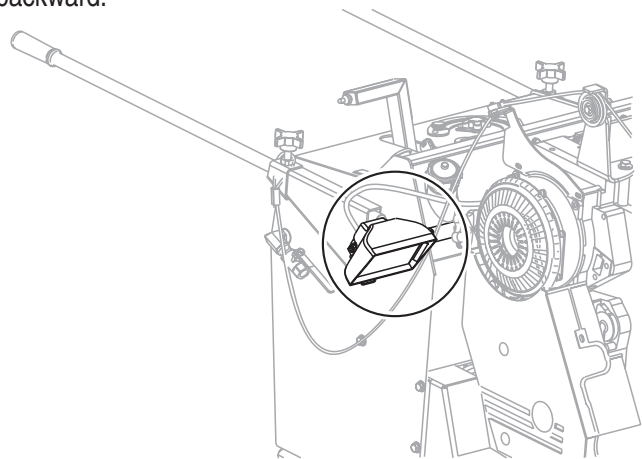

Figure 36. Night Light

STOW CS4030 SAW — MAINTENANCE

MAINTENANCE

WARNING

Certain maintenance operations or machine adjustments require specialized knowledge and skill. Attempting to perform maintenance operations or adjustments without the proper knowledge, skills or training could result in equipment damage or injury to personnel. If in doubt, consult your dealer.

When performing maintenance operations on the saw or engine, follow all safety messages and rules for safe operation stated here and at the beginning of this manual.

See the engine manufacturer's manual supplied with your machine for appropriate maintenance schedule and troubleshooting guide for problems.



WARNING

Accidental starts can cause severe injury or death!



ALWAYS place the ON/OFF switch in the OFF position.

Disconnect negative battery cable from battery before servicing.



Engine and muffler surfaces can get **HOT!** Allow to cool before servicing.

ALWAYS ensure saw is **SECURELY** placed on appropriate blocks or jackstands when performing maintenance requiring the saw to be elevated.

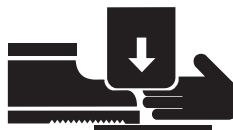

CAUTION

Avoid slips and falls!

Clean up all engine oil, hydraulic oil, and diesel fuel spills immediately.



Maintenance Schedule

Daily (8-10 Hours)

1. Check fluid levels in engine and reservoir; fill as necessary.
2. Visually inspect for wear and damage.
3. Visually inspect for engine leaks.
4. Check or replace the engine air filters as necessary.
5. Check operation of Emergency Stop Button.

Monthly (125-150 Hours)

1. Change Hydraulic oil and filter. (First 125 hours, then every 250 hours.)
2. Change Engine oil and filter.

Yearly (500-600 Hours)

1. Replace fuel filter cartridge, v-belt, and intake air cleaner.
2. Check fuel lines for leakage.
3. Check battery cables and connectors.
4. Check engine monitoring and warning system.

Air Cleaners (Daily)

The saw utilizes both a primary air filter and a safety air filter, (Figure 38). The air filter restriction light, (Item A, Figure 37) on the engine status indicator (Item B, Figure 37), will illuminate when the filter is plugged.

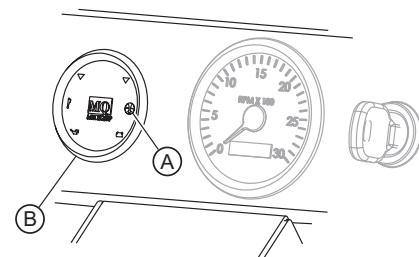

Figure 37. Air Filter Restriction Light

Empty the dust discharge valve daily and clean the discharge slot from time to time. (Figure 38)

While the air filters should be checked daily and replaced when necessary, there is no need to "over-service" the air filters. That is, they require no cleaning and do not require the use of oil. If the primary filter becomes clogged, simply replace it.

STOW CS4030 SAW — MAINTENANCE

Never blow dirt out with compressed air or try to clean with fluids. Damage can occur to the filter, and if re-installed, can result in damage to the engine.

CAUTION

Safety Air Filters are **NOT** intended to be used for primary air filtration. When the Primary Air Filter becomes clogged, replace it immediately. **DO NOT** run the saw using the Safety Filter *only*.

Replace the Safety Filter element every fourth Primary Filter element. See Table 8, Air and Oil Filter Chart for part numbers.

Table 8. Air and Oil Filter Chart

FILTER	PART NUMBER
Primary Air Filter	P772579
Safety Air Filter	P775300
Engine Oil Filter	306012 (Deutz #1174416-SP)
Hydraulic System Filter	306006
Fuel Filter	304010 (Donaldson #1174696)

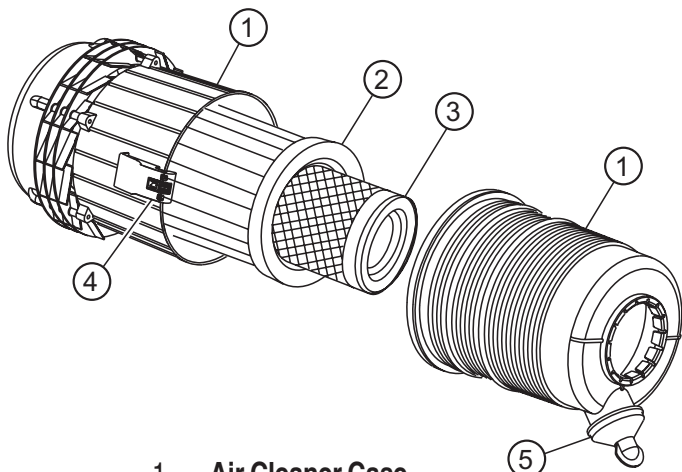

1. Air Cleaner Case
2. Primary Filter Element
3. Safety Filter Element
4. Latch
5. Dust Discharge Valve

Figure 38. Air Cleaner Components

CAUTION

Operating the engine with loose or damaged air cleaner components could allow unfiltered air into the engine causing premature wear and failure.

Engine

This saw features a 30 HP DEUTZ Tier II diesel engine, F2L2011. Complete engine service details and recommendations can be found in the engine manufacturer's manual included with the saw.

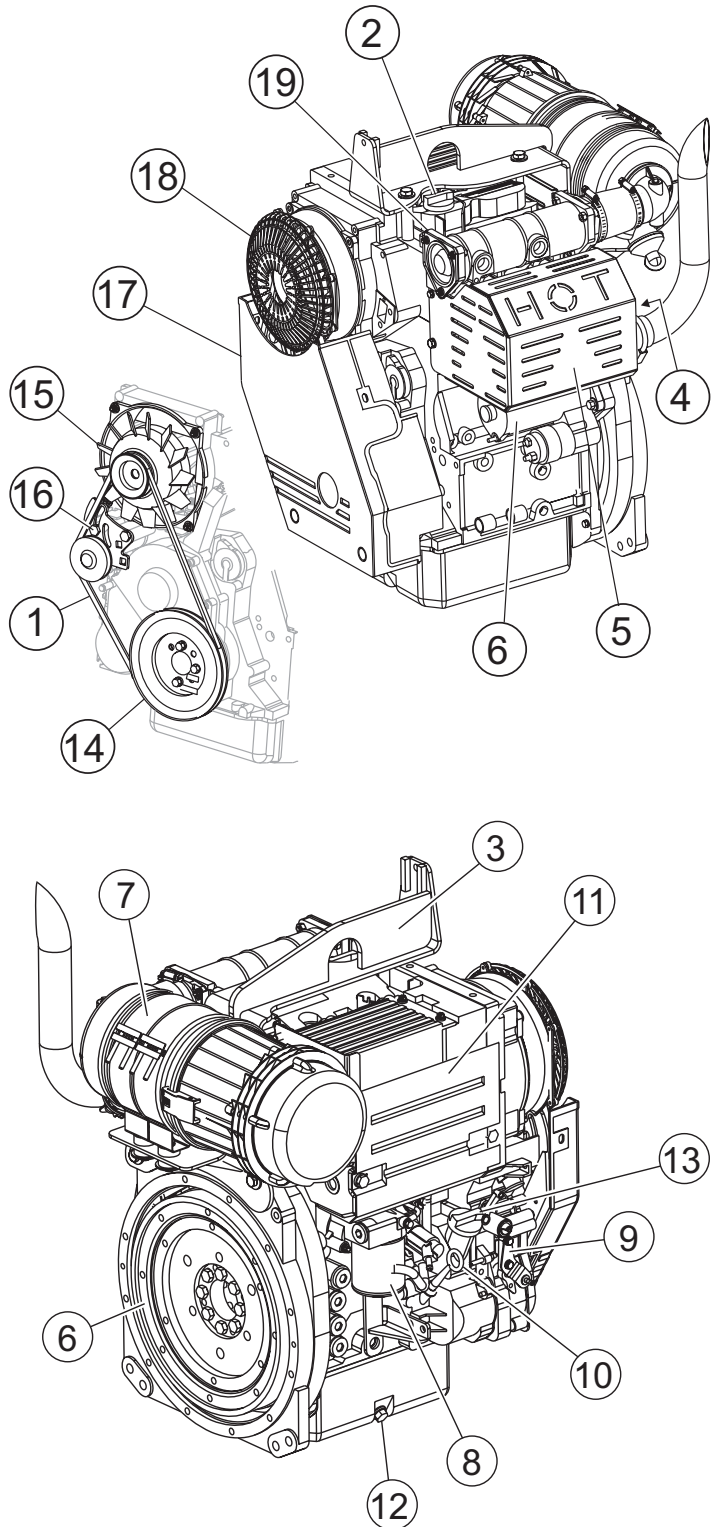

STOW CS4030 SAW — MAINTENANCE

1. V-belt
2. Rocker Arm Cover
3. Fuel Injection Pump
4. Alternator
5. Starter motor
6. Flywheel
7. Air Filter/Cooling System
8. Fuel Filter
9. Throttle Lever
10. Dipstick (engine oil)
11. Engine Oil Filter
12. Drain Plug (engine oil)
13. Filler Port (engine oil)
14. Crank Shaft V-pulley
15. Cooling Fan
16. Adjustment bolt (V-belt tension)
17. Belt Guard
18. Fan Cover
19. Oil Cooler

2. Remove the oil filler cap (Figure 39, Item 13), and fill engine crankcase with recommended type oil as listed in Table 9. Fill to the upper limit of dipstick.
3. Crankcase capacity with filter replacement is 8 quarts, (7.57 liters). Refer to Table 9 for recommended viscosity grade for temperature range.

Table 9. Recommended Viscosity Grades

SAE 0W-30, 0W-40										
SAE 5W-30, 5W-40										
SAE 10W-30, 10W-40										
SAE 15W-40										
SAE 20W-50										
°F	-20	0	20	32	40	60	80	100		
°C	-30	-20	-10	0	10	20	30	40		
TEMPERATURE RANGE EXPECTED BEFORE NEXT OIL CHANGE										

Figure 39. Engine Service Areas

Checking Engine Oil

1. Check engine oil level daily before starting the engine.
2. When checking or adding oil, place the machine so the engine is level.
3. Pull the engine oil dipstick from its holder, (Item 10, Figure 39).
4. Determine if engine oil is low. Oil should be between the upper and lower limit (add oil) lines.
5. If oil is below the "Add Engine Oil" line, add oil up to the upper limit on the dipstick. Allow enough time for any oil to make its way to the oil pan before rechecking.

CAUTION

DO NOT overfill the oil pan with engine oil. Always keep the engine oil level at the upper limit lines on the dipstick due to the tilting of the engine during operation.

Changing Engine Oil And Filter

1. Change the engine oil after the first 5 hours of use, then change every 6 months or 125 hours.

Oil Filter (125 Hours)

1. Replace the engine oil filter (Figure 40) every oil change or 125 hours. Refer to your engine manual for specific details to perform this operation.

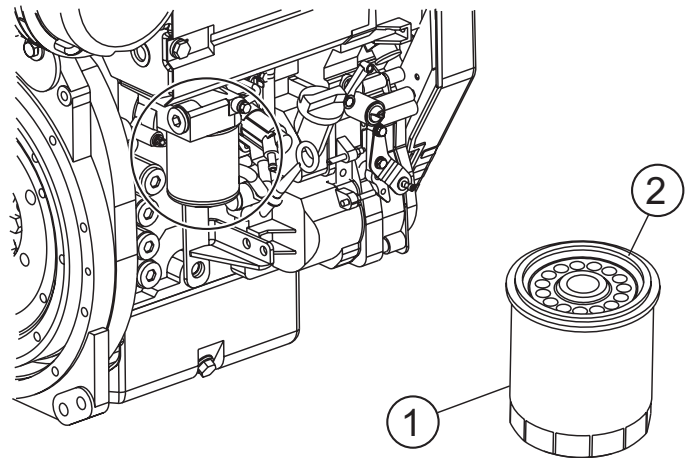

1. Engine Oil Filter
2. Filter Seal

Figure 40. Oil Filter

2. Be sure to coat the **seal** of the new oil filter with clean engine oil.
3. Spin on new filter until seal make contact with surface, then tighten additional 2/3 to 3/4 turn.

STOW CS4030 SAW — MAINTENANCE

Fuel Filter (200 Hours)

- Replace the engine fuel filter (Figure 41) every 500 hours. Refer to your engine manual for specific details to perform this operation.

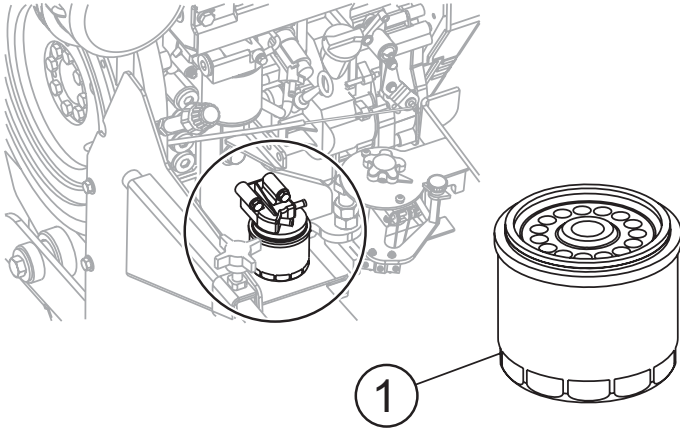

Figure 41. Fuel Filter Removal

Oil And Fuel Lines

- Check the oil and fuel lines and connections regularly for leaks or damage. Repair or replace as necessary.

Engine Tune-Up

- See your engine manual for specific information on tuning up your engine.

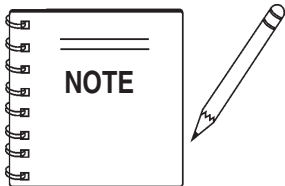

See the engine manual supplied with your machine for appropriate engine maintenance schedule and troubleshooting guide for problems.

At the front of the book (Page 9) there is a “Daily Pre-Operation Checklist”. Make copies of this checklist and use it on a daily basis.

Disconnect negative (ground) battery cable and secure away before attempting any service or maintenance on the saw.

Lubrication

This saw has many service-saving features, including fully enclosed oil bath lubricated Blade Shaft bearings that require no daily lubrication.

This saw has 5 grease fittings.

Grease these fittings every 125 hours of operation with a premium grade waterproof E.P. (extreme pressure) grease.

! WARNING

Prevent Crush Injury!

When necessary, ensure the saw is securely placed on blocks before servicing.

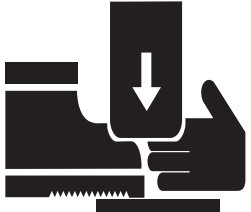

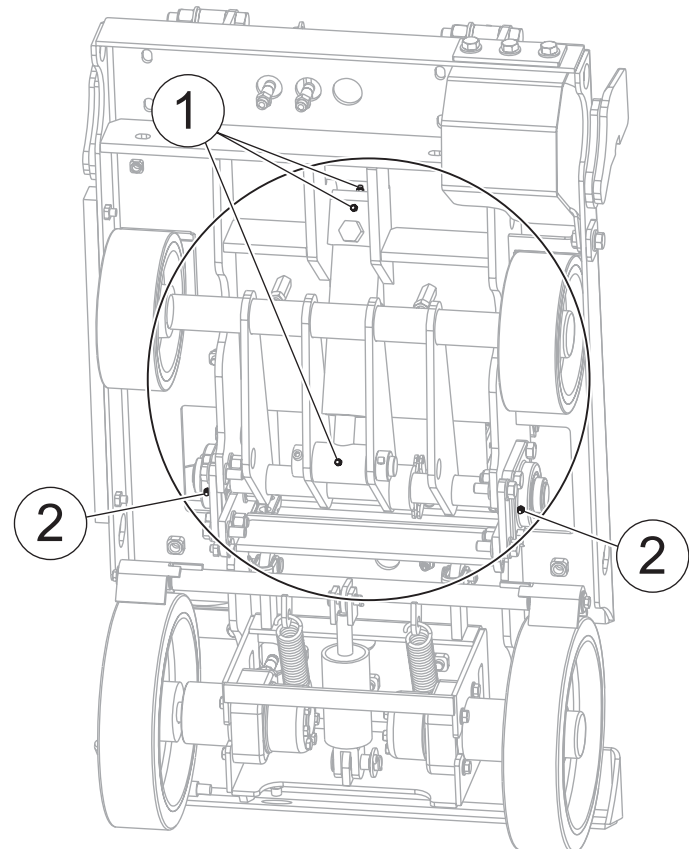

1. Front Axle Pivot Bearing
2. Hydraulic Lift Cylinder

Figure 42. Grease Fittings

Cooling System

The Deutz 2011 Series Engine uses a robust, heavy duty oil cooler system to cool the engine. The cooling system will benefit from periodic inspection and cleaning.

1. Disconnect the Air Intake Hose. Remove the three nuts and torx screws (Item 1, Figure 43).
2. Remove 3 bolts that mount the air filter bracket to the engine, (item 2) and the two bolts holding the Lifting Bale (Item 3).
3. Remove the Air Box (Item 4) and Lifting Bale as a unit, exposing the oil cooler unit.

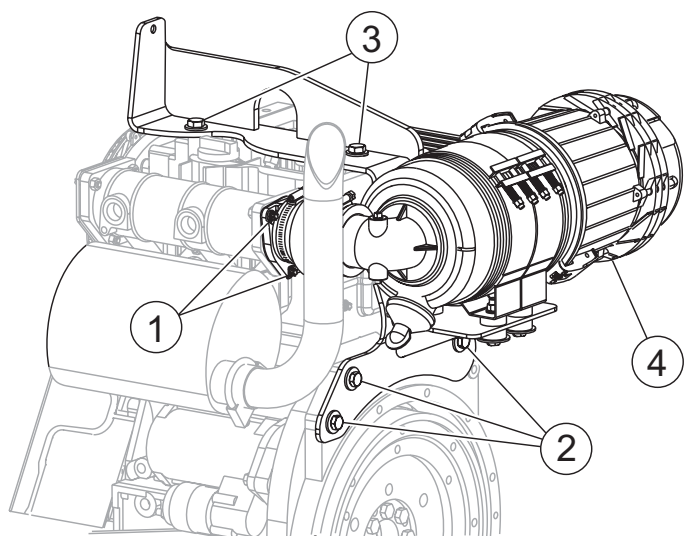

Figure 43. Air Cleaner Removal

4. Use a nylon bristle brush to gently brush the underside of the oil cover to break loose any accumulated dirt and debris.
5. Using compressed air, carefully blow from the top of the oil cooler to remove lodged dirt and debris. Blow out any dirt out of the Air Box.
6. Use compressed air to next blow accumulated dirt and debris from the Fan Air Intake, Fan, and Fan Tunnel.
7. Using a non-caustic degreasing agent, soak entire oil cooler and let sit for several minutes. With low pressure water, such as a garden hose with a spray nozzle, thoroughly rinse Oil Cooler and Air Box out.
8. Re-install Air Box Cover, Air Filter Assembly and mount, and tighten Air Intake Hose connector.

Refer to your engine manual for additional information.

Battery/Charging System

WARNING

Flammable, explosive gas. (produces hydrogen gas while charging or during operation). Keep area around battery well ventilated and keep from any fire source.

Battery electrolyte contains corrosive, toxic chemical. (dilute sulfuric acid). Avoid contact with eyes and skin.

Shock or Fire due to electric short-circuit. Disconnect battery cables before inspecting electrical system and never "spark" battery terminals to test for charge.

This saw uses a Group 75, 12 Volt, 850 CCA (cold cranking amp) AGM Technology battery.

1. Check and clean battery terminals for corrosion.
2. Never attempt to charge a battery that is frozen. The battery can explode unless first allowed to thaw.
3. Disconnect the negative terminal (-) of the battery during storage. If unit will be stored where ambient temperature will drop to -15°C or less, remove and store battery in a warm, dry place.

STOW CS4030 SAW — MAINTENANCE

Replacing the Battery

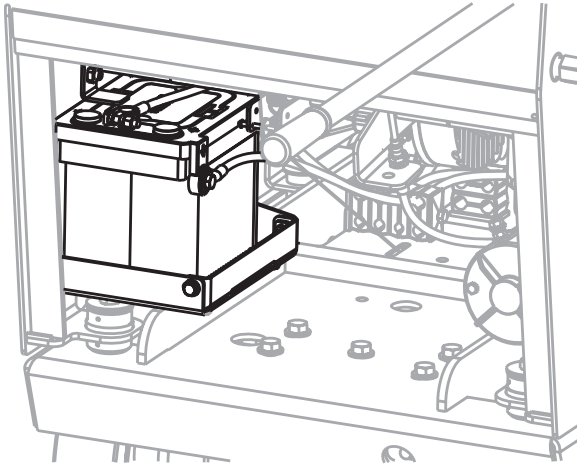

Figure 44. Battery Location

1. Remove rear access panel.
2. Disconnect both negative battery cables first, then disconnect both positive battery cables to prevent arcing.
3. Remove top battery retainer clip, (Item A, Figure 45).
4. Remove lower battery retainer, (Item B, Figure 45).
5. Carefully slide battery out of tray. Dispose of properly in accordance with ordinances and regulations in your area.
6. Install new battery in tray.
7. Install lower battery retainer. Push retainer tightly against battery and tighten bolt.
8. Install top battery retainer clip.
9. Re-connect both positive cables first, then both negative cables to prevent arcing.

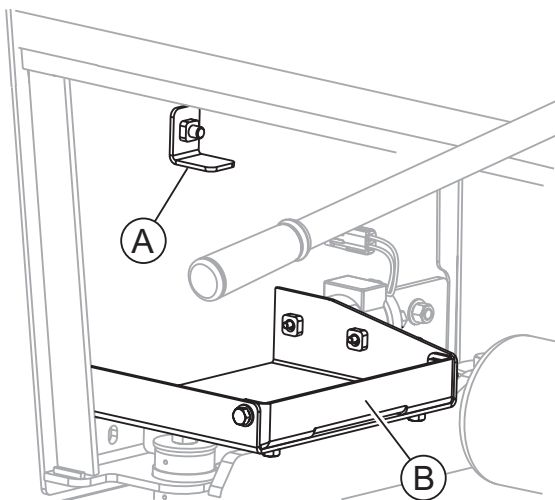
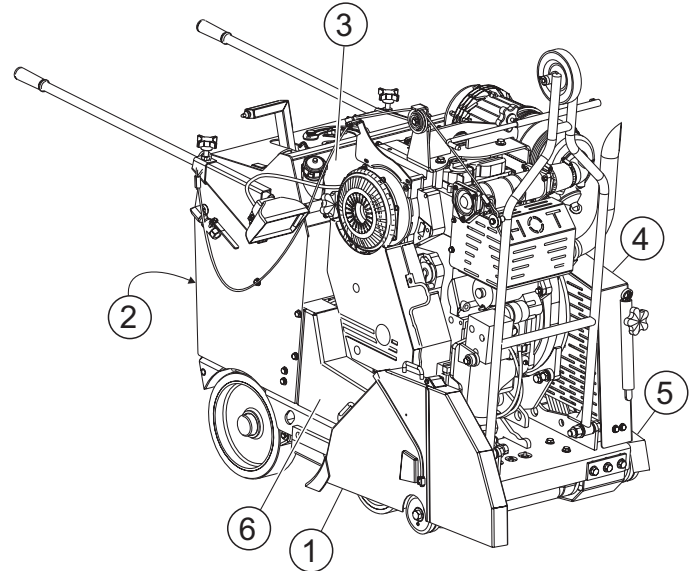

Figure 45. Battery Tray and Retainer Clips

Removable Guards and Access Panels

For ease of service access, the guards and access panels shown in Fig. 46 are removable.



1. **Blade Guard**
2. **Rear Access Panel**
3. **Console Access Panel**
4. **Belt Guard**
5. **Flange Guard**
6. **Engine Guard**

Figure 46. Guards & Panels

WARNING

Replace guards and panels prior to starting the engine.

STOW CS4030 SAW — MAINTENANCE

Belts and Pulleys

This saw uses a 6 groove 3V X 500 Optibelt for it's Drive Belt System and a Hydrostatic Pump Belt, (AX-35).

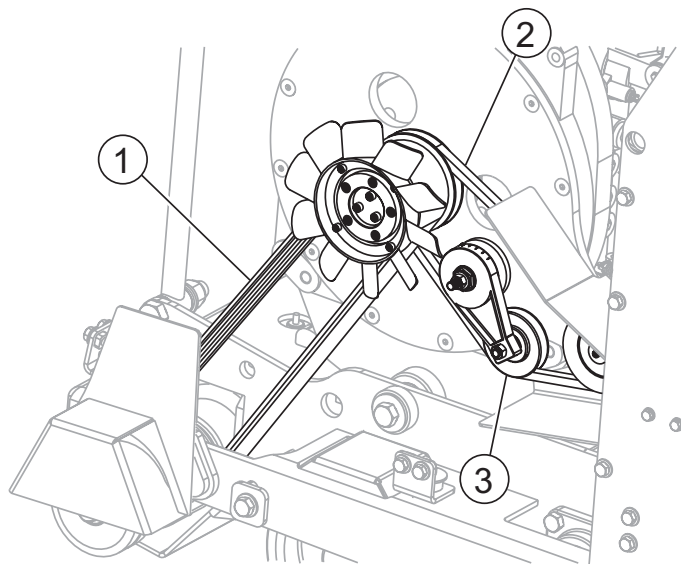

1. Blade Shaft Drive Belt
2. Transaxle Drive Belt
3. Belt Tensioner Pulley

Figure 47. Belt Locations

V-Belt Tension

CAUTION

Keep belts clean of foreign material that may cause slippage. Never dress belts as this can cause premature failure.

Ideal V-Belt tension is the lowest tension at which the belt will not slip under peak load conditions.

The V-belt tension on this saw is controlled by the hydraulic system that actuates the Blade Shaft Engage/Disengage System. Hydraulic pressure exerted on the engine tilt cylinder applies force on the Belt Drive System to engage Bladeshaft rotation.

Engine must be at idle when engaging or dis-engaging bladeshaft drive:

To STOP Bladeshaft Rotation:

Push rocker switch labeled BLADESHAFT forward. Engine will tilt forward, dis-engaging the drive belt.

To START Bladeshaft Rotation:

Push rocker switch labeled BLADESHAFT backward. Engine will tilt back, engaging the belt drive.

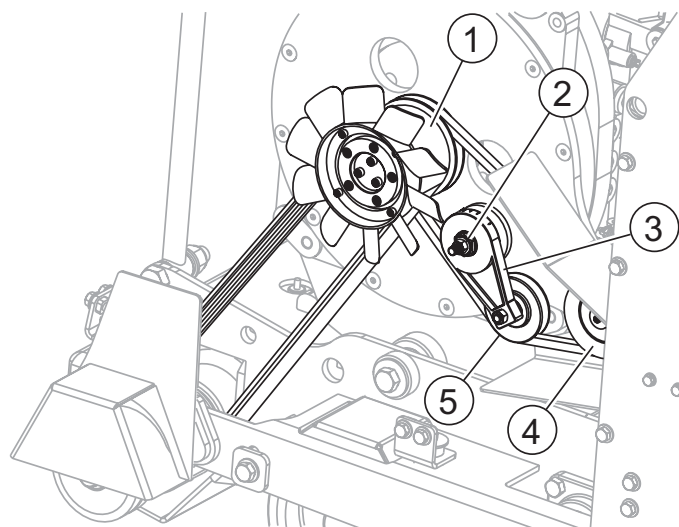

1. Engine Sheave
2. Tensioner Nut
3. Tensioner Base
4. Jackshaft Pulley
5. Tensioner Pulley

Figure 48. Belt Drive System

STOW CS4030 SAW — MAINTENANCE

Rotary Belt Tensioner

The Rotary Belt Tensioner system uses a 9/16"-headed nut and a 15/16" or 1" nut to set belt tension by positioning an arm between the Tensioner Pulley and the Tensioner Base. Ridges on the Base mark the amount of tension.

Adjust to 3-1/2 notches on the tensioner:

1. Loosen the 9/16" nut.
2. Rotate the Tensioner Nut clockwise until the desired belt tension is achieved.
3. Tighten the 9/16" nut.

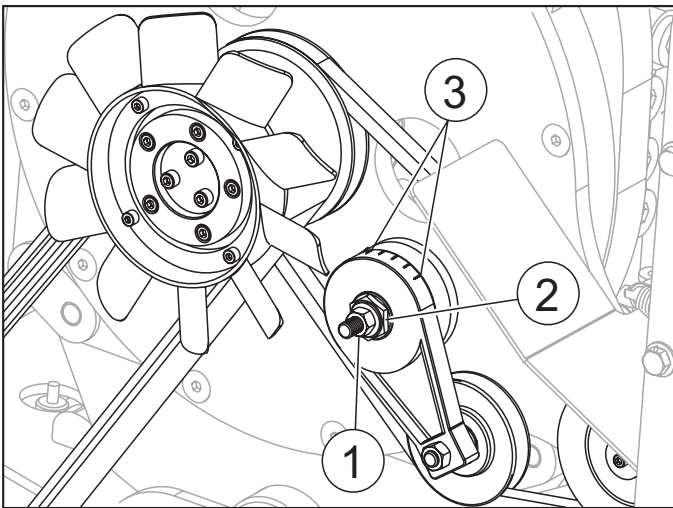

1. 9/16" Nut
2. Tensioner Nut
3. Adjustment Notches

Figure 49. Tension Adjustment Notches

Blade Shaft Maintenance

The fully enclosed Blade Shaft eliminates most maintenance. Should the Blade Shaft need service or repair however, contact the manufacturer for details.

Blade Shaft Assembly

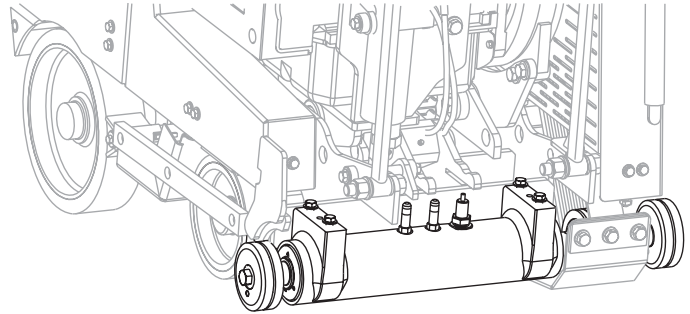
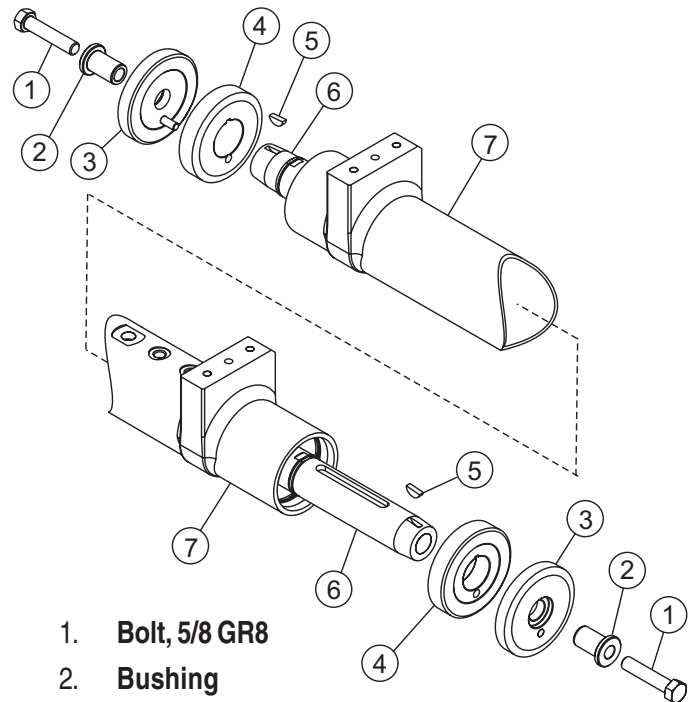

Figure 50. Blade Shaft Assembly

External Components



1. Bolt, 5/8 GR8
2. Bushing
3. Outer Flange
4. Inner Flange
5. Drive Key
6. Bladeshaft
7. Bladeshaft Housing

Figure 51. Blade Shaft External Components

STOW CS4030 SAW — MAINTENANCE

Removal and Replacement

To ensure correct Blade Shaft/Wheel alignment this operation should be performed by and authorized Service Center.

Blade Alignment

Maintaining proper blade and drive system alignment will allow the saw to cut lines that are straight without much effort. Therefore the Blade Shaft Flanges MUST be equidistant to the sides of the saw, (+/- .030"). See Figure 52 below where distance A must equal distance B.

The second requirement for the blade is that it MUST be square to horizontal (90° to flat surface). See Figure 52.

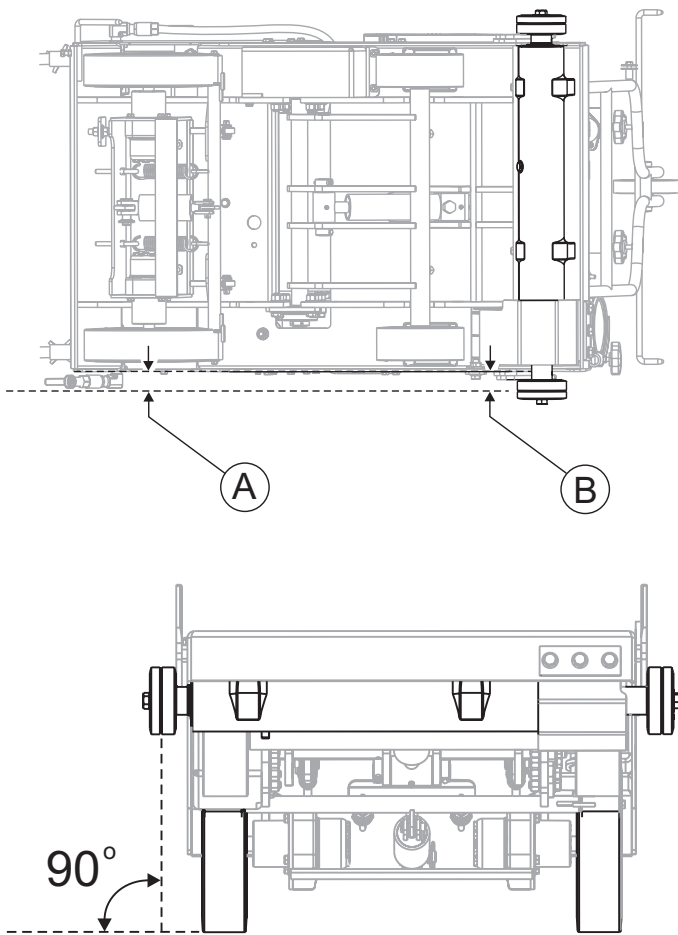

Figure 52. Blade Alignment Requirements

Drive System Alignment

In addition to Blade alignment, maintaining proper blade and drive system alignment will allow the saw to cut lines that are straight without much effort. Therefore the Front Wheels and Blade Shaft Axles MUST be at right angles to the frame edge.

In Figure 53 you see the distance "A" on the right side is shown as "A + .187"" which means that the distance between centers of the front and rear drive axles are 3/16" longer than on the opposite side. This will have the effect of causing the saw to "steer" slightly to the left. After becoming familiar with the saw's particular sawing characteristics, the operator may wish to have this alignment altered to fit his own preferences or to fit a particular application.

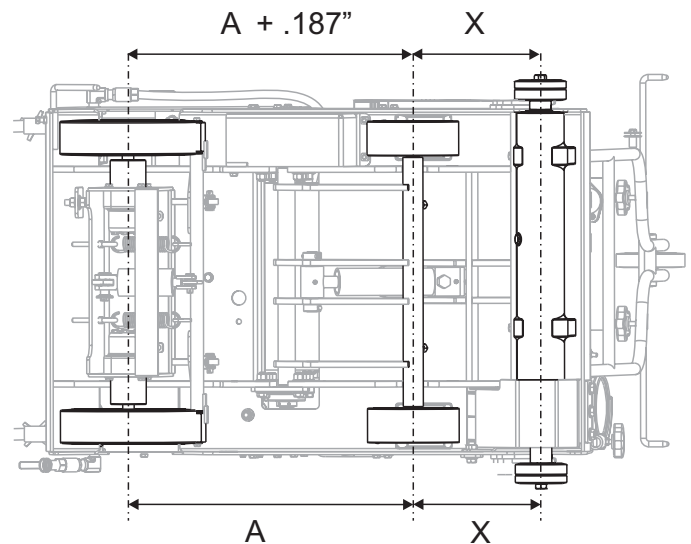

Figure 53. Wheel Alignment Requirements

Drive System Alignment Adjustment

The drive wheels are aligned by adjusting the entire rear drive assembly.

1. Loosen the Wheel Mount Assembly Attachment Bolts just enough to move the Wheel Mount Assembly. Do not completely loosen the Bolts.
2. Loosen and tighten the Alignment Jackscrew nuts to move the Wheel Mount Assembly, and thus the wheels, in the appropriate direction to achieve the desired alignment distance. (See Fig. 53)

- Lock down the Wheel Mount Assembly Attachment Bolts when the appropriate alignment distance is set.

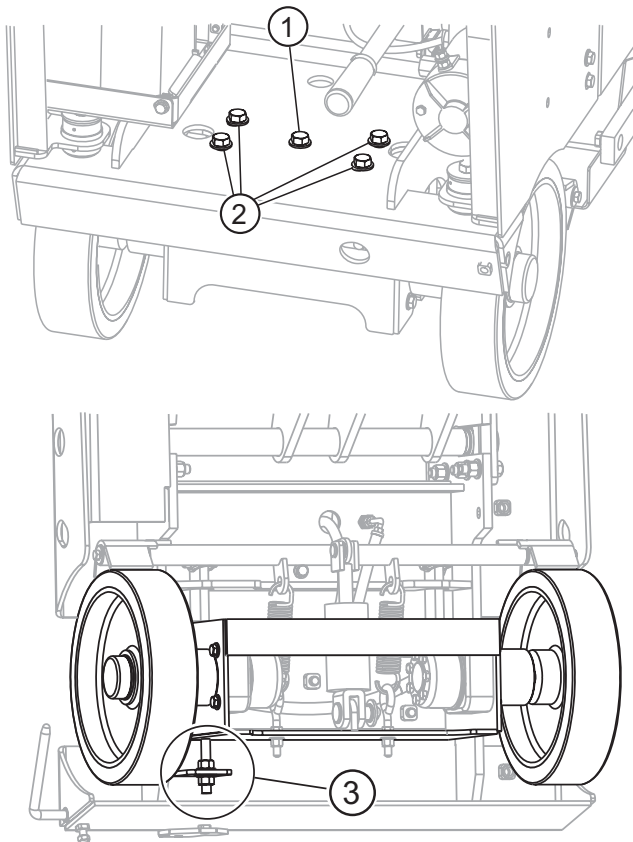

- Pivot Attachment Bolt
- Adjustment Attachment Bolts
- Adjustment Screw

Figure 54. Drive Wheel Alignment Bolt Locations

Blade Flange Removal/Installation

Correct removal or installation of the Inner Blade Flange requires Flange Puller (p/n 18503) as shown in figure 55.

! WARNING

If unfamiliar with this operation seek assistance or training from someone that is familiar with this operation. Because of the tapered fit between the Blade Flange and Blade Shaft, 5-10 tons of force is required to release the inner flange from the Blade Shaft. Both parts and tools can become dangerous projectiles if instructions are not followed properly.

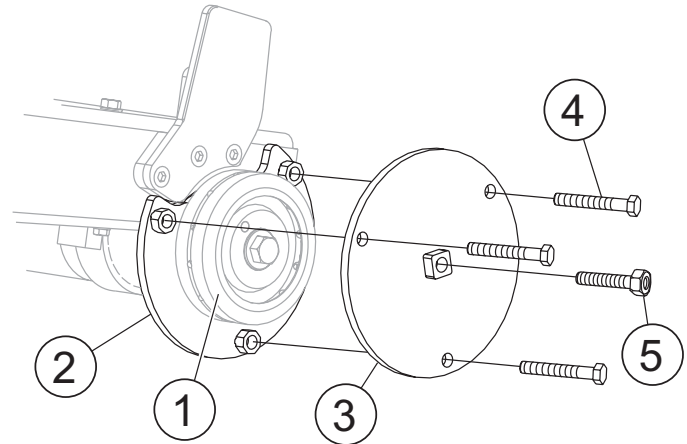

- Blade Flange
- Horseshoe Puller Plate
- Puller Plate
- Perimeter Bolt
- Center Puller Bolt

Figure 55. Blade Flange Puller

Removing the Inner Blade Flange

- With the Outer Blade Flange in place, loosen the Blade Mounting Bolt approximately 1/4".

! WARNING

The Outer Flange **MUST** be in place to prevent the Puller assembly and Inner Flange from flying off when the taper breaks loose. Injury or equipment damage could otherwise result.

- While the 3 perimeter bolts hold the two Puller Plates together, slide the Horseshoe Plate of the Flange Puller behind the (Shaft) side of the Inner Flange.
- Tighten the center puller bolt to remove the Inner Flange from the Blade Shaft.

STOW CS4030 SAW — MAINTENANCE

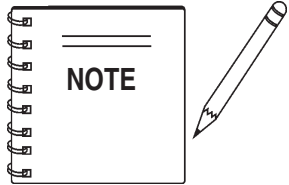

If the Inner Flange does not readily break free from the tapered Blade Shaft while the center puller bolt is tightened, lightly tap on the center puller bolt to allow the flange to break free from the shaft.

Installing the Inner Blade Flange

1. Ensure that the tapered portion of the Blade Shaft and the Inner Blade Flange are clean and free of burrs or indentations. Clean and repair as necessary.
2. Ensure the Drive Key is in place.
3. Slide the Inner Flange onto the tapered portion of the Blade Shaft.

CAUTION

DO NOT use lubricant of any kind. Lubricant prevents the tapered surface of the Flange and Shaft from mating properly.

4. Install the Outer Blade Flange, Flange Bushing, and Mounting Bolt.
5. Tighten with a 1/2" impact wrench to seat the tapered surfaces of the Inner Flange and Blade Shaft.

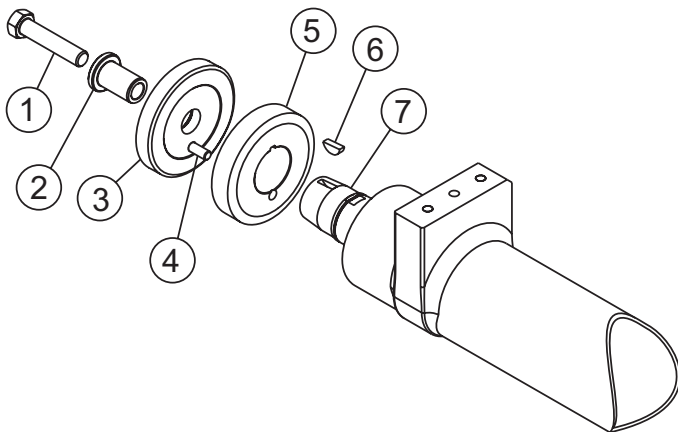

1. Mounting Bolt
2. Flange Bushing
3. Outer Flange
4. Dowel Pin
5. Inner Flange
6. Drive Key
7. Blade Shaft

Figure 56. Inner Blade Flange Installation

6. Loosen the Mounting Bolt and remove the Outer Flange and Bushing.
7. Inspect the Inner Flange to ensure the proper seating of the tapered fit. The Inner Flange should be seated between .030" and 0.0" (flush) to the end of the Blade Shaft. (See Figure 57)

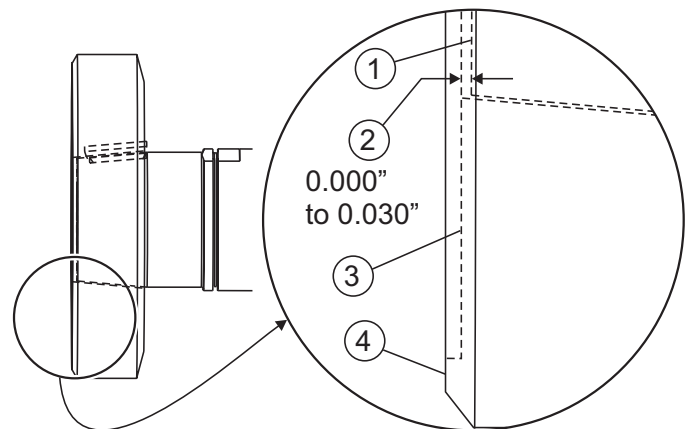

1. Blade Shaft
2. Tolerance
3. Inner Flange Inside Face
4. Surface Area to be Checked For Runout While Rotating

Figure 57. Inner Flange Seating

8. Test to ensure that the Inner Flange does not wobble when rotated. Use a dial indicator on the face of the Flange. (Item 4 Figure 57.) Maximum tolerance is .002" runout on the face of the Flange when rotated.

Circuit Breakers

Thermal circuit breakers are located behind the console access cover at the top of the console.

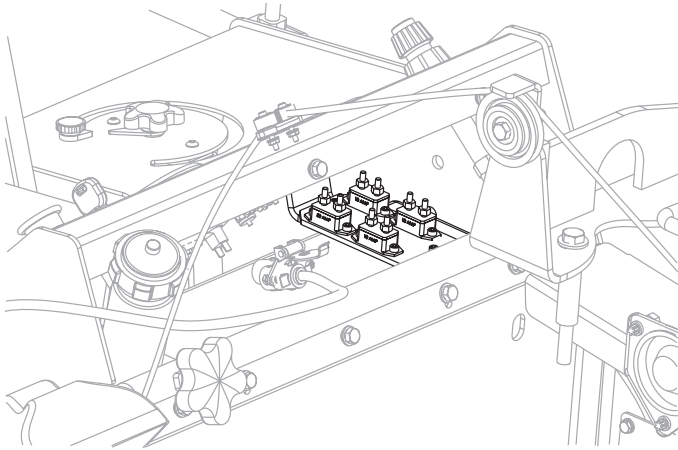
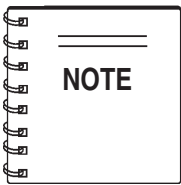

Figure 58. Circuit Breakers

Under normal circumstances the circuit breakers do not require service. They automatically re-set when an overload condition is corrected. If a breaker is cycling on and off, locate the cause of the electrical overload and repair as required.

Maximum Cut Depth Adjustment



While adjustment of the Depth Stop Limiting Bolts can change the maximum usable cut depth, they should not be adjusted to compensate for unit "wobble" or blade/cut problems. These indications are a result of other issues that should be addressed.

The saw comes factory-adjusted for maximum usable cut depth. Should this setting need to be changed, perform the following:

1. With the BLADE REMOVED, park the saw on a flat and level surface.
2. Fully lower the saw onto the Depth Limiting Stop Bolts.
3. Measure the distance from the Blade Flanges to the surface.
4. If adjustment is required, loosen Locknut on the right-side Depth Limiting Stop Bolt and screw bolt in several turns until it no longer makes contact with the axle.

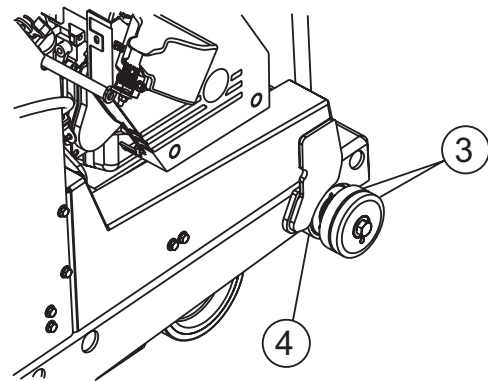
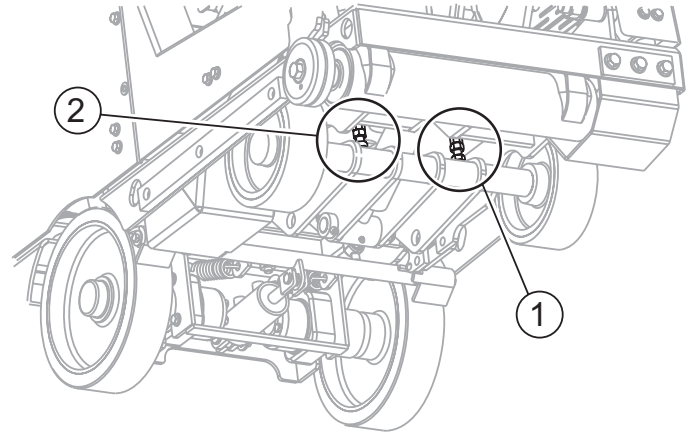

1. **Left-Side Stop Bolt**
2. **Right-Side Stop Bolt**
3. **Blade Flanges**
4. **Blade Shaft Housing**

Figure 59. Depth Adjustment

5. Adjust the left-side Stop Bolt in or out until the Blade Flange or Lower Belt Guard achieves 1/8" to 3/16" ground clearance. Tighten lock nut on left side.
6. Raise saw and place 2 jack stands under the Blade Shaft Housing.
7. While holding the Raise-Lower Switch in the Lowering Position, raise the front axle assembly until it contacts the left-side Depth Limiting Stop Bolt.
8. While holding the axle firmly against the left-side Depth Limiting Stop Bolt, screw the right-side Depth Stop Limiting Bolt out until it makes contact with the axle. Tighten lock nut on right side.

Following this procedure will prevent torsional stresses being applied to the frame when fully lowered due to uneven adjustment of Depth Limiting Stop Bolts.

STOW CS4030 SAW — MAINTENANCE

PTO Drive Maintenance

Disassembly of the PTO Drive and replacement of the PTO Drive Sheave/Bearing Assembly requires the PTO Bearing Puller, p/n 18610. The Sheave/Bearing Assembly is not serviceable and must be replaced as a complete unit. Reference Figure 60 for components.

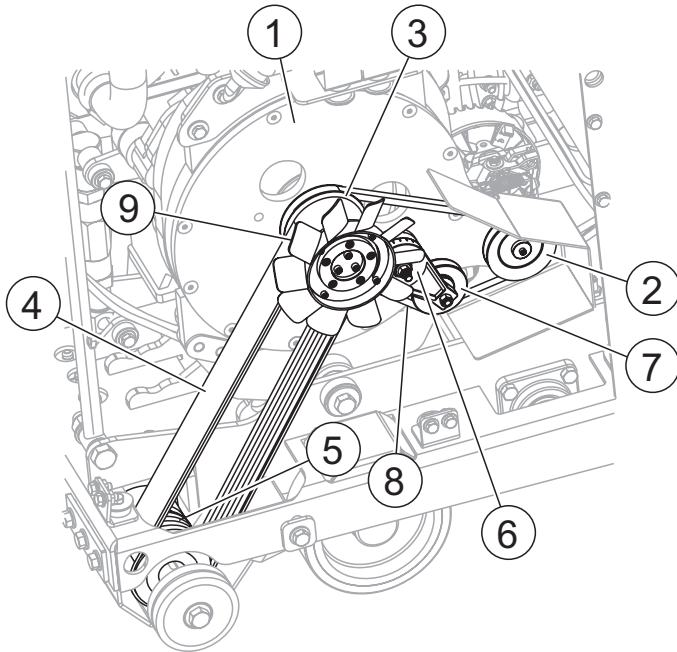

1. Engine Adapter Plate
2. Idler Arm Belt
3. Drivebelt Pulley
4. Drivebelt
5. Bladeshaft Pulley
6. Idler Arm Tensioner
7. Idler Pulley
8. Idler Arm Belt
9. Fan

Figure 60. PTO Drive Assembly

Raise-Lower System

The saw uses a 12-volt hydraulic pump and hydraulic cylinder to power the raise-lower system.

1. Check hydraulic oil level daily.
2. When checking or adding hydraulic oil, place the machine so the saw frame is level to get an accurate reading.

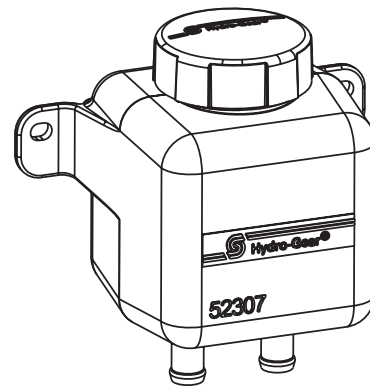
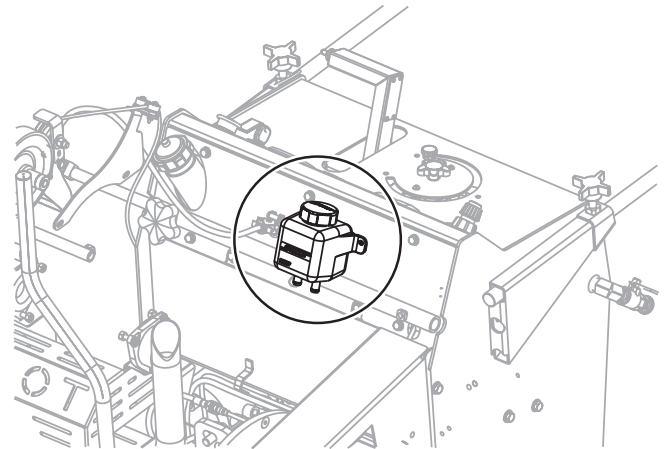
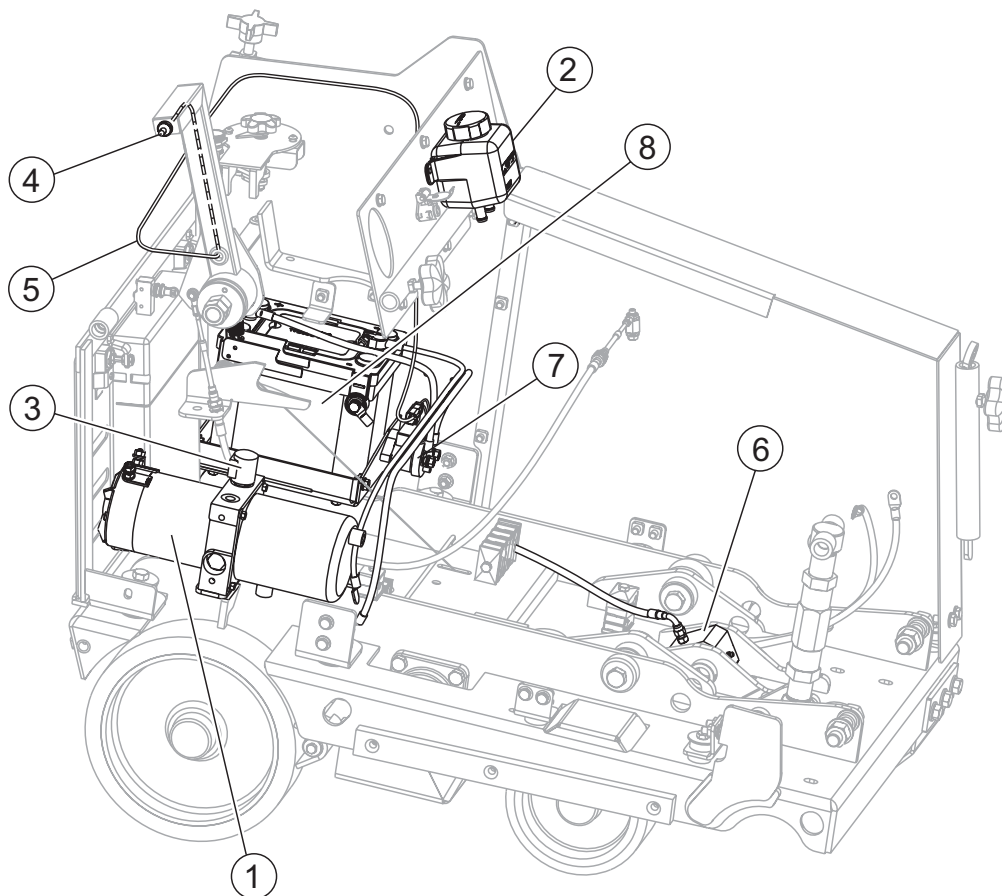

Figure 61. Hydraulic Oil Reservoir

3. Hydraulic oil should be 1/2" to 1" in the Oil Reserve when cold.
4. If hydraulic oil level is low add oil to 1/2" to 1".
5. Use **15W-40** premium grade engine oil.



1. Pump Motor
2. Lift Pump Reservoir
3. Raise-Lower Valve (Solenoid)
4. Raise-Lower Toggle
5. Raise-Lower Wire Harness
6. Lift Cylinder
7. Lift Pump Solenoid

Figure 62. Raise-Lower System

Raise-Lower System Troubleshooting

Refer to the following table to assist in troubleshooting the Raise-Lower System.

Table 10. Raise-Lower System Troubleshooting	
Indication	Possible Causes
Won't Raise	battery discharged, raise-lower solenoid faulty, cables loose or damaged, defective wiring
Won't Lower	switch bad, faulty wiring connection, coil bad, valve cartridge bad

STOW CS4030 SAW — MAINTENANCE

F-N-R Control Adjustment

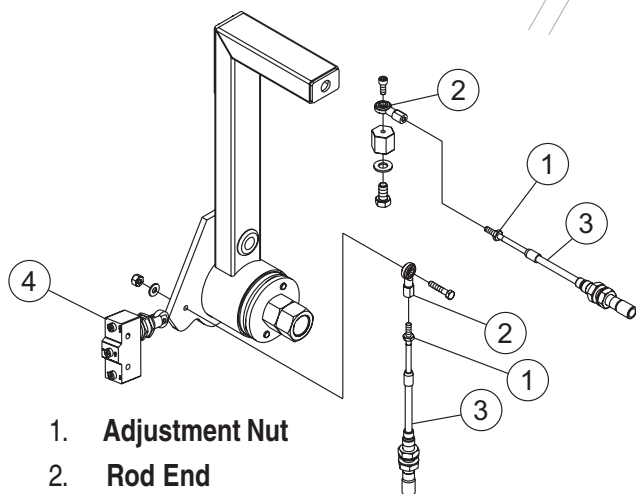
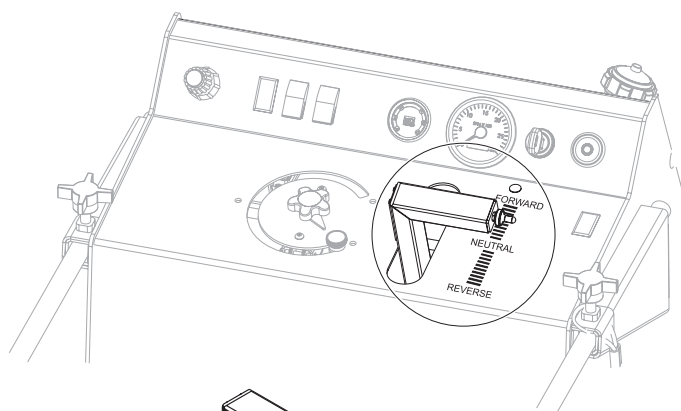

1. Adjustment Nut
2. Rod End
3. Push-Pull Cable
4. Neutral Safety Switch

Figure 63. F-N-R Control Adjustment

Control (Cable) adjustment for the F-N-R should not normally be necessary, however, some adjustment can be made on each of the Rod End adjustment nuts.

Hydraulic System Maintenance

! WARNING

NEVER use your hand to find hydraulic leaks. Use a piece of wood or cardboard. Hydraulic fluid injected into the skin must be treated by a knowledgeable physician immediately or severe injury or death can occur.



Many hydraulic problems are a result of low fluid levels. Before checking any other possibilities, make sure the hydraulic fluid level is correct.

1. Correct hydraulic fluid level.
2. Plugged hydraulic oil filter
3. Loose or leaking fittings.
4. Ruptured/damaged hydraulic lines.
5. Faulty hydraulic pump.

Hydraulic Oil System

1. Check hydraulic oil level daily.
2. When checking or adding hydraulic oil, place the machine so the saw frame is level to get an accurate reading.
3. Hydraulic oil should be 1/2" to 1" in the Oil Reserve when cold.
4. If hydraulic oil level is low add oil to 1/2" to 1".
5. Use **15W-40** premium grade engine oil.
6. Change oil and filter annually.

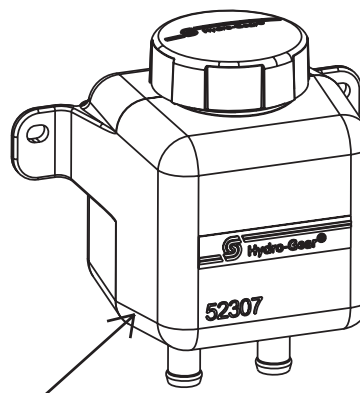
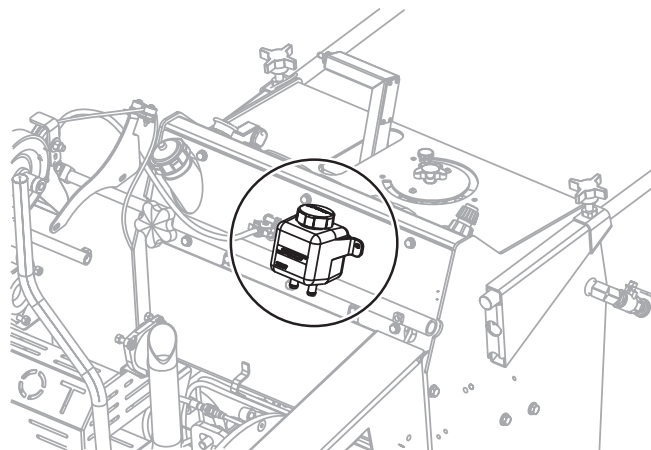

Figure 64. Oil Reserve Fill Line

STOW CS4030 SAW — MAINTENANCE

1. Hydraulic Reservoir
2. Filter
3. Pump
4. Lift Cylinder
5. Wheel Motor
6. Engine Tilt Cylinder
7. Motor
8. Pump Body

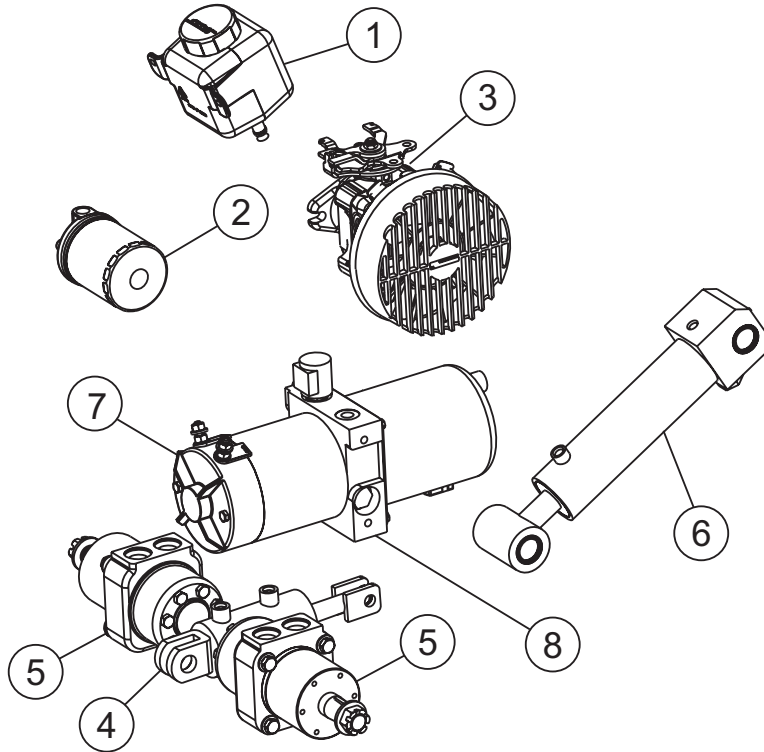

Figure 65. Hydraulic System

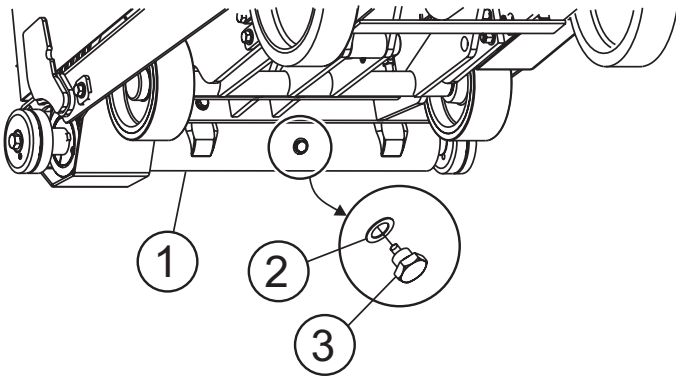

Figure 66. Hydraulic System Drains

1. Place an oil drain pan beneath the Blade Shaft drain plug.
2. Remove the drain plug from the bottom of the Blade Shaft Housing.

3. Collect and dispose the used oil (and filter) in accordance with ordinances and regulations of your area.
4. Remove used oil filter.
5. After oil is drained, reinstall drain plug.
6. Pre-fill and install a new oil filter.

CAUTION

To prevent hydraulic pump damage, pre-fill the filter with oil prior to installing it.

7. Add oil to the system reservoir.
8. The reservoir will need to be filled several times.
9. Run the engine for 1-2 minutes to cycle the oil throughout the system.
10. Add oil as required.
11. Repeat process until oil level is stable after running engine.

STOW CS4030 SAW — MAINTENANCE

Tips When Draining and Filling the Hydraulic Oil System

1. It will take 3-4 quarts to fill the hydraulic system when new, and somewhat less when changing the oil.
2. Remove the oil reservoir cap to speed oil draining.
3. When re-filling the system, raise the saw halfway up, then lift the rear of the saw until the Blade Flanges touch the ground. This will help to speed the filling process.
4. After filling the system, jack the saw up so the drive wheels are off the ground. Start the saw and move the Control Handle half way into FORWARD to purge air out of the system.

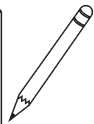
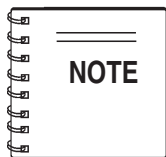

If the Blade Shaft is drained completely, it will require approximately 1 gallon to refill. If the transaxle is drained as well, it will require approximately 1 additional gallon.

Slurry Control Strip

If your saw is not already equipped with it, a Slurry Control Strip is available from the manufacturer.

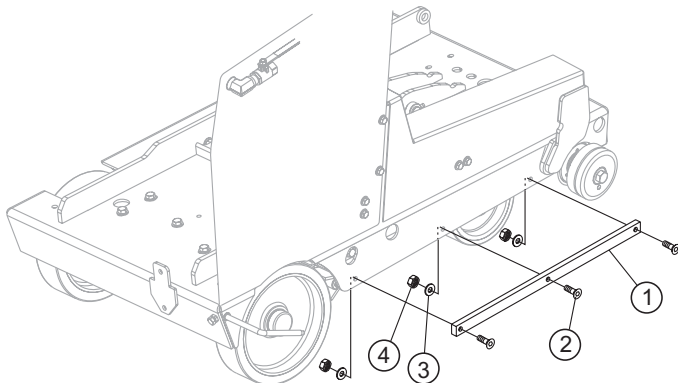

1. **Slurry Control Strip**
2. **3/8" FHSC Screw**
3. **Flat Washer**
4. **Nyloc Nut**

Figure 69. Slurry Control Strip

Long Term Storage

- Remove the battery.
- Drain fuel from fuel tank and fuel lines.
- Clean exterior with a cloth soaked in clean oil.
- Store unit covered with plastic sheet in moisture and dust-free location out of direct sunlight.

CAUTION

Never store the saw with fuel in the tank for any extended period of time. Always clean up spilled fuel immediately.

Decommissioning Saw/Components

Decommissioning is a controlled process used to safely retire a piece of equipment that is no longer serviceable. If the equipment poses an unacceptable and unrepairable safety risk due to wear or damage or is no longer cost effective to maintain, (beyond life-cycle reliability) and is to be decommissioned, (demolition and dismantlement), the following procedure must take place:

1. Drain all fluids completely. These may include oil, gasoline, hydraulic oil and antifreeze. Dispose of properly in accordance with local and governmental regulations. Never pour on ground or dump down drains or sewers.
2. Remove battery and bring to appropriate facility for lead reclamation. Use safety precautions when handling batteries that contain sulfuric acid, (See page 16).
3. The remainder can be brought to a salvage yard or metal reclamation facility for further dismantling.

STOW CS4030 SAW — TROUBLESHOOTING

TABLE 11. TROUBLESHOOTING (ENGINE)

SYMPTOM	POSSIBLE CAUSE	SOLUTION
Will not start, no power with key "ON".	Emergency Stop Button pushed in?	Pull out E-Stop Button.
	Battery disconnected or discharged?	Check cable connections, charge or replace battery.
	Ignition switch/wiring defective?	Replace ignition switch. Check wiring.
Will not start. No fuel present.	Fuel not available in fuel tank (tank empty)?	Fill with correct type of fuel.
	Fuel filter/lines clogged?	Replace fuel filter or fuel lines.
	Fuel tank cap breather hole clogged?	Clean or replace fuel tank cap.
	Air in fuel line?	Bleed fuel line.
	Injection valve clogged or defective?	Clean or replace.
Difficult to start, "fuel is available and compression is normal".	Wrong fuel type?	Flush fuel system, and replace with correct type of fuel.
	Contaminated fuel system? (Water, dirt)	Flush fuel system.
	Air cleaner dirty?	Replace air cleaner.
Difficult to start, "fuel is available and compression is low".	Suction/exhaust valve stuck or protruded?	Re-seat valves.
	Piston ring and/or cylinder worn?	Replace piston rings and/or piston.
	Cylinder head not tightened properly?	Torque cylinder head bolts
	Head gasket damaged?	Replace head gaskets.

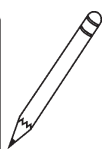
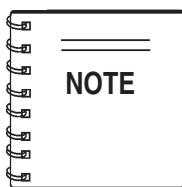

Certain operations referred to in this troubleshooting section such as re-seating valves or replacing piston rings may require special tools and must be performed by trained and competent personnel.

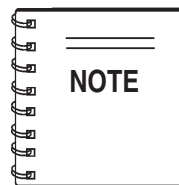

For further engine troubleshooting, see your engine owner's manual

STOW CS4030 SAW — TROUBLESHOOTING

TABLE 12. TROUBLESHOOTING (ENGINE, CONTINUED)

SYMPTOM	POSSIBLE CAUSE	SOLUTION
"Weak in power" compression is proper and does not misfire.	Intake air restricted?	Clear air intake of dirt and debris. Replace air cleaner elements as necessary.
	Improper fuel or contaminated fuel?	Flush fuel system if contaminated. Refill with clean fuel of prescribed quality.
	Injection Line leaks?	Repair or replace lines.
	Charge air line leaking?	Repair or replace line.
"Weak in power" compression is proper but misfires.	Water in fuel system?	Flush fuel system and replace with correct type fuel.
	Ignition defective?	Replace ignition.
	Damage, or worn Injector orifices?	Clean or replace injectors.
Engine overheats.	Wrong fuel type?	Flush fuel system, and replace with correct type of fuel.
	Intake air restricted?	Clear air intake of dirt and debris. Replace air cleaner elements as necessary.
	Injection Valve defective?	Replace Injection valve.
	Cooling fins dirty?	Clean cooling fins.
	Oil level to low or too high?	Adjust oil to proper level.
Rotational speed fluctuates.	Governor adjusted correctly?	Adjust governor.
	Governor spring defective or missing?	Replace governor spring.
	Fuel flow restricted?	Check entire fuel system for leaks or clogs.
Starter malfunction.	Loose, damaged wiring?	Ensure tight, clean connections on battery and starter.
	Battery insufficiently charged?	Recharge or replace battery.
	Starter damaged or internally shorted?	Replace Starter.

STOW CS4030 SAW — TROUBLESHOOTING

TABLE 13. BLADE TROUBLESHOOTING

SYMPTOM	POSSIBLE PROBLEM	SOLUTION
Blade slows or stops cutting.	Blade too hard for the material being cut?	Consult Dealer or Multiquip for correct blade. Try cutting very soft material (sandstone, silica brick, cinder block) to "Redress" the blade.
	Engine torque diminished because of loose or worn drive-belts?	Re-tension belts or replace.
	Insufficient engine power?	Check throttle setting. Refer to Engine troubleshooting.
	Improper direction of rotation?	Check that the blade is properly oriented and rotational arrow points in a "Down-Cutting" direction.
	Blade is slipping on the blade shaft?	Check that the blade & flange pin are properly installed on the blade shaft.
Blade does not cut straight and/or true.	Blade misaligned on saw?	Check alignment integrity.
	"Cut Gap" excessive or blade wobble?	Check blade shaft and flange for wear, damage and blade seating.
	Blade is excessively hard for the material being cut?	Check specification of the blade with the material being cut. Consult Dealer or Multiquip for information.
	Blade being used at improper RPM?	Ensure blade surface feet per minute speed (SFPM) is approximately 10,000.
	Blade improperly mounted on arbor shoulders and flanges?	Ensure blade is properly affixed on the blade shaft.
	Excessive force applied to blade while cutting?	DO NOT force the blade in the cut. Apply a slow and steady pace when sawing.
Blade discoloring, cracking and/or wearing excessively.	Blade wearing out on one side and not the other?	Check blade shaft and flange for wear, damage and blade seating.
	Blades too hard for the material being cut?	Consult Dealer or Multiquip for correct blade. Try cutting very soft material (sandstone, silica brick, cinder block) to "Redress" the blade.
	Blade improperly mounted on arbor shoulders and flanges?	Ensure blade is properly affixed on the blade shaft.
	Blade not receiving enough cooling water?	Ensure proper flow & volume of water is provided for wet cutting blades.
	Arbor hole out of round?	Ensure blade is properly affixed on the blade shaft.
	Incorrect blade chosen for material being cut?	Check specification of the blade with the material being cut. Consult Dealer or Multiquip for information.
	Excessive force applied to blade while cutting?	Diamond abrasive material worn away or burnished into the metal. Check saw for alignment or damage and replace saw blade.

STOW

A DIVISION OF MULTIQUIP INC.

Terms and Conditions of Sale STOW Construction Equipment

PAYMENT TERMS

Terms of payment for unit sales are 2% 15 days net 30 days from date of invoice unless otherwise specifically stated on our invoice. Parts invoices have terms of net 10 days.

Minimum parts billing is \$15.00 net.

Applicable discounts will be computed on merchandise value only. Late charges will be assessed at prevailing rates. Cash discounts cannot be taken on current billings if any previously billed amounts are past due.

FREIGHT POLICY

Freight policy is established to offer customers every advantage possible. Due to bulk freight ratings on some equipment and other shipping considerations, freight policies differ by equipment type. Actual back freight may be charged for shipments originating from other than specified FOB warehouses. **See Freight Policy for details.**

All STOW domestic sales are FOB nearest available designated MQ/STOW warehouse. Export orders are ex-works factory located in Carson, CA or Boise, ID.

Additions to orders already shipped cannot be accepted for freight minimums.

Should STOW elect to make partial shipments of an order originally complying with the "freight allowed" requirements, transportation charges will be absorbed by STOW on any subsequent shipment applying to that order.

All other orders will be shipped collect or prepaid with charges added to the invoice. STOW's responsibility ceases when a signed manifest has been obtained from the carrier, and any claim for shortage or damage must be settled between the consignee and the carrier.

Parts: FOB Carson, California or Boise, Idaho. **See Freight Policy for details and additional discounts.**

DROP SHIPMENTS

STOW reserves the right to refuse Drop Shipments outside the normal service area of the purchasing dealer.

FIELD WAREHOUSES

Field Warehouses are currently located in California, Georgia, Idaho, Iowa, and New Jersey

SPECIAL EXPEDITING SERVICE

The higher of a \$35.00 surcharge or actual costs will be added to the invoice for special handling, including bus shipments, or in cases where STOW personnel must personally deliver the equipment or parts to the carrier.

RETURNED GOODS POLICY

Return shipments may be accepted and credit allowed, subject to the following provisions.

1. A Returned Material Authorization (RMA) must be approved by STOW prior to shipment. Approvals for returned goods must be with just cause and are at the sole discretion of STOW. A copy of the Authorization must accompany the shipment to the designated Warehouse.
2. Parts being returned must be listed as currently supplied on the current parts list.
3. Parts must be in new and resalable condition in the original package, with part numbers clearly marked.
4. Units and accessories must be current models in the latest price list and in new and resalable condition.
5. Special order items are not returnable for credit.
6. Credit on returned parts and units will be issued at actual dealer net price at time of purchase less 15% restocking charge.
7. All returned shipments are to be made to the STOW designated receiving point, freight prepaid at the sender's expense.

The sender will be notified of any material received that does not meet the above provisions. Such material will be held for 30 days from notification pending instructions. If a reply is not received within 30 days, the material will be returned to the sender at his expense with no credit issued.

PRICING, REBATES AND SPECIFICATIONS

Every effort will be made to provide adequate notice of changes; however, prices and equipment specifications are subject to change without notice.

Price changes are effective on a specific date and all orders received on or after that date will be billed at the revised price.

Rebates for price reductions and added charges for price increases will not be made for stock in dealer inventory at the time of a price change.

STOW reserves the right to quote and sell direct to Government agencies and to Original Equipment Manufacturer accounts who use our products as integral parts of their own products.

LIMITATION OF SELLER'S LIABILITY

STOW shall not be liable hereunder for damages in excess of the purchase price of the item with respect to which damages are claimed and in no event shall STOW be liable for loss of profit or good will or for any other special, consequential or incidental damages.

LIMITATION OF WARRANTIES

There are no warranties, express or implied, made by STOW hereunder on Products manufactured or distributed by it except the warranty against defects in material and workmanship on new Products to the original purchaser, as set forth in the STOW New Product Limited Warranty.

Effective: July 15, 2003

STOW

A DIVISION OF MULTIQUIP INC.

Atlanta • Boise • Newark • Quebec, Canada
Manchester, UK • Rio de Janeiro, BR • Puebla, MX

STOW CONSTRUCTION EQUIPMENT

POST OFFICE BOX 6254
CARSON, CALIFORNIA 90749
310-661-4242 • 877-BUY-STOW
FAX: 310-604-9237
E-MAIL: stow@stowmfg.com
www.stowmfg.com

OPERATION MANUAL

HERE'S HOW TO GET HELP

PLEASE HAVE THE MODEL AND SERIAL NUMBER *ON-HAND* WHEN CALLING

PARTS DEPARTMENT

800-427-1244 FAX: 800-672-7877

310-537-3700 FAX: 310-637-3284

SERVICE DEPARTMENT

800-478-1244 FAX: 310-537-4259

310-537-3700

TECHNICAL ASSISTANCE

800-478-1244 FAX: 310-631-5032

WARRANTY DEPARTMENT

800-421-1244, EXT. 279 FAX: 310-537-1173

310-537-3700, EXT. 279

SALES DEPARTMENT

310-661-4242 FAX: 310-604-9237

877-289-7869 (877-BUY-STOW)

© COPYRIGHT 2008, MULTIQUIP INC.

Multiquip Inc, and the STOW logo are registered trademarks of Multiquip Inc. and may not be used, reproduced, or altered without written permission. All other trademarks are the property of their respective owners and used with permission.

This manual MUST accompany the equipment at all times. This manual is considered a permanent part of the equipment and should remain with the unit if resold.

The information and specifications included in this publication were in effect at the time of approval for printing. Illustrations, descriptions, references and technical data contained in this manual are for guidance only and may not be considered as binding. Multiquip Inc. reserves the right to discontinue or change specifications, design or the information published in this publication at any time without notice and without incurring any obligations.

Your Local Dealer is:

STOW

A DIVISION OF MULTIQUIP INC.
Atlanta • Boise • Newark • Quebec, Canada
Manchester, UK • Rio de Janeiro, BR • Puebla, MX

MQ STOW CONSTRUCTION EQUIPMENT

A DIVISION OF MULTIQUIP INC.

POST OFFICE BOX 6254

CARSON, CA 90749

310-537-3700 • 888-252-MQ STOW [888-252-7869]

FAX: 310-537-1986 • FAX: 800-556-1986

E-MAIL: MQ STOW@multiquip.com • WWW:

stowmfg.com