

PARTS MANUAL

STOW

A DIVISION OF MULTQUIP INC.

STAY-LEVEL HANDLEBAR SERIES MODELS

CS706016

CS706020

CS706026

CS706030

CS706036

PAVEMENT SAW (DEUTZ BF3L2011 DIESEL ENGINE)

Revision #7 (06/06/08)

To find the latest revision of this
publication, visit our website at:
www.multiquip.com



THIS MANUAL MUST ACCOMPANY THE EQUIPMENT AT ALL TIMES.

P/N 37560



CALIFORNIA — Proposition 65 Warning

Engine exhaust and some of its constituents, and some dust created by power sanding, sawing, grinding, drilling and other construction activities contains chemicals known to the State of California to cause cancer, birth defects and other reproductive harm. Some examples of these chemicals are:

- Lead from lead-based paints.
- Crystalline silica from bricks.
- Cement and other masonry products.
- Arsenic and chromium from chemically treated lumber.

Your risk from these exposures varies, depending on how often you do this type of work. To reduce your exposure to these chemicals: **ALWAYS** work in a well ventilated area, and work with approved safety equipment, such as dust masks that are specially designed to filter out microscopic particles.

⚠️ WARNING



SILICOSIS WARNING

Grinding/cutting/drilling of masonry, concrete, metal and other materials with silica in their composition may give off dust or mists containing crystalline silica. Silica is a basic component of sand, quartz, brick clay, granite and numerous other minerals and rocks. Repeated and/or substantial inhalation of airborne crystalline silica can cause serious or fatal respiratory diseases, including silicosis. In addition, California and some other authorities have listed respirable crystalline silica as a substance known to cause cancer. When cutting such materials, always follow the respiratory precautions mentioned above.

⚠️ WARNING

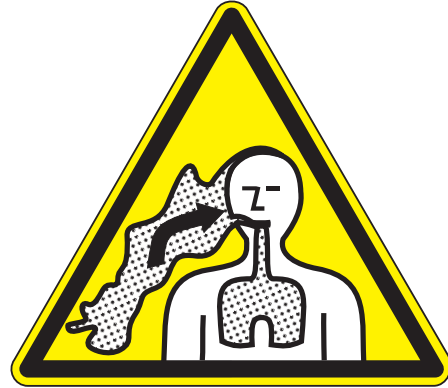

RESPIRATORY HAZARDS

Grinding/cutting/drilling of masonry, concrete, metal and other materials can generate dust, mists and fumes containing chemicals known to cause serious or fatal injury or illness, such as respiratory disease, cancer, birth defects or other reproductive harm. If you are unfamiliar with the risks associated with the particular process and/or material being cut or the composition of the tool being used, review the material safety data sheet and/or consult your employer, the material manufacturer/supplier, governmental agencies such as OSHA and NIOSH and other sources on hazardous materials. California and some other authorities, for instance, have published lists of substances known to cause cancer, reproductive toxicity, or other harmful effects.

Control dust, mist and fumes at the source where possible. In this regard use good work practices and follow the recommendations of the manufacturers or suppliers, OSHA/NIOSH, and occupational and trade associations. Water should be used for dust suppression when wet cutting is feasible. When the hazards from inhalation of dust, mists and fumes cannot be eliminated, the operator and any bystanders should always wear a respirator approved by NIOSH/MSHA for the materials being used.

CS7060 SERIES SAWS

Proposition 65 Warning 2

Silicosis/Respiratory Warnings 3

Table of Contents 4

Parts Ordering Procedures 5

Explanation of Code in Remarks Column 6

Suggested Spare Parts 7

Nameplates and Decals 8-9

Control Panel Decals 10-11

Electrical Control Assembly 12-13

Console Mounts Assembly 14-15

Rear Console Access Panel Assembly 16-17

Light Connector/Dash Access Assembly 18-19

Belt and Engine Guards Assembly 20-21

Depth Indicator/Stop Switch Assy. (Old Style) 22-23

Depth Indicator/Stop Switch Assy. (New Style) 24-25

F-N-R Assembly 26-27

Fuel Assembly 28-29

Battery Assembly 30-31

Stay-Level Handlebars Assembly 32-33

Handlebar Boot Assembly 34-35

Water System Assembly 36-37

Engine Assembly 38-39

Throttle Control Assembly 40-41

Engine Mounts Assembly 42-43

Air Cleaner Assembly 44-45

Muffler Assembly 46-47

Lift Bail Assembly 48-49

Platform Guards/Rear Pointer Assembly 50-51

Wheel Drive Assembly 52-53

Front Axle Assembly 54-55

Hydraulic System Assembly 56-57

Engine Pivot Cylinder Assembly 58-59

Hydraulic Hoses Assembly 60-61

Hydraulic Fittings and Clamps Assembly 62-63

Front Pointer Assembly 64-65

Belt Drive Assembly 66-69

Drive Pulley Assembly 70-71

Bladeshaft Assembly 72-73

16", 20", 26" Bladeguard Assembly 74-75

30", 36" Bladeguard Assembly 76-77

Optional Weight Kit Assembly 78-79

Terms and Conditions of Sale — Parts 80

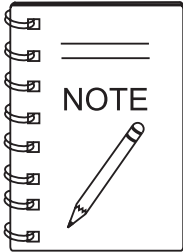

Specifications are subject to change without notice.

PARTS ORDERING PROCEDURES

When ordering parts, please supply the following information:

- Dealer account number
- Dealer name and address
- Shipping address (if different than billing address)
- Return fax number
- Applicable model number
- Quantity, part number and description of each part
- Specify preferred method of shipment:
 - ✓ FedEx or UPS Ground
 - ✓ FedEx or UPS Second Day or Third Day
 - ✓ FedEx or UPS Next Day
 - ✓ Federal Express Priority One
 - ✓ DHL
 - ✓ Truck

Note: Unless otherwise indicated by customer, all orders are treated as "Standard Orders", and will ship within 24 hours. We will make every effort to ship "Air Shipments" the same day that the order is received, if prior to 2PM west coast time. "Stock Orders" must be so noted on fax or web forms.



Here's how to get help...

Please have the model and serial number on hand when calling.

STOW MAIN OFFICE

18910 Wilmington Ave. 800-421-1244
 Carson, CA 90746 FAX: 310-537-3927
 Email: stow@stowmfg.com
 Internet: www.stowmfg.com

SALES DEPARTMENT

310-661-4242 Fax: 310-604-9237
 877-289-7869 (877-BUY-STOW)

PARTS DEPARTMENT

800-427-1244 FAX: 800-672-7877
 310-537-3700 FAX: 310-637-3284

SERVICE DEPARTMENT

800-478-1244 FAX: 310-537-4259
 310-537-3700

TECHNICAL ASSISTANCE

800-478-1244 FAX: 310-631-5032

WARRANTY DEPARTMENT

800-421-1244, EXT. 279 FAX: 310-537-1173
 310-537-3700, EXT. 279

Place Your Parts Order Via Web or Fax For Even More Savings!

(Domestic USA Dealers Only)

Extra Discounts!

All parts orders which include complete part numbers and are received by our automated web parts order system, or by fax qualify for the following extra discounts:

Ordered via	Standard orders	Stock orders (\$750 list and above)
Fax	3%	10%
Web	5%	10%

Special freight allowances when you order 10 or more line items via Web or Fax! **

FedEx Ground Service *at no charge for freight*
No other allowances on freight shipped by any other carrier.

***Common nuts, bolts and washers (all items under \$1.00 list price) do not count towards the 10+ line items.*

NOTE: DISCOUNTS ARE SUBJECT TO CHANGE

STOW

A DIVISION OF MULTIQUIP INC.
STOW CONSTRUCTION EQUIPMENT
 A DIVISION OF MULTIQUIP INC.

POST OFFICE BOX 6254 CARSON, CA 90749
 888-252-STOW [888-252-7869] 310-537-3700
 FAX: 310-537-1986 FAX: 800-556-1986
 E-MAIL: stow@multiquip.com INTERNET: www.stowmfg.com

Direct TOLL-FREE access to our Parts Department:

Toll-free nationwide — 800-427-1244

Toll-free FAX — 800-6-PARTS-7 (800/672-7877)

EXPLANATION OF CODE IN REMARKS COLUMN

The following section explains the different symbols and remarks used in the Parts section of this manual. Use the help numbers found on the back page of the manual if there are any questions.

The contents and part numbers listed in the parts section are subject to change **without notice**. Multiquip does not guarantee the availability of the parts listed.

Sample Parts List:

NO.	PART NO.	PART NAME	QTY.	REMARKS
1	12345	BOLT	1	INCLUDES ITEMS W/*
2*		WASHER, 1/4 IN.		NOT SOLD SEPARATELY
2*	12347	WASHER, 3/8 IN. ...	1	MQ-45T ONLY
3	12348	HOSE	A/R	MAKE LOCALLY
4	12349	BEARING	1	S/N 2345B AND ABOVE

NO. Column

Unique Symbols - All items with same unique symbol (*, #, +, %, or >) in the number column belong to the same assembly or kit, which is indicated by a note in the "Remarks" column.

Duplicate Item Numbers - Duplicate numbers indicate multiple part numbers are in effect for the same general item, such as different size saw blade guards in use or a part that has been updated on newer versions of the same machine.



When ordering a part that has more than one item number listed, check the remarks column for help in determining the proper part to order.

PART NO. Column

Numbers Used - Part numbers can be indicated by a number, a blank entry, or TBD.

TBD (To Be Determined) is generally used to show a part that has not been assigned a formal part number at time of publication.

A blank entry generally indicates that the item is not sold separately or is not sold by Multiquip. Other entries will be clarified in the "Remarks" Column.

QTY. Column

Numbers Used - Item quantity can be indicated by a number, a blank entry, or A/R.

A/R (As Required) is generally used for hoses or other parts that are sold in bulk and cut to length.

A blank entry generally indicates that the item is not sold separately. Other entries will be clarified in the "Remarks" Column.

REMARKS Column

Some of the most common notes found in the "Remarks" Column are listed below. Other additional notes needed to describe the item can also be shown.

Assembly/Kit - All items on the parts list with the same unique symbol will be included when this item is purchased.

Indicated by:

"INCLUDES ITEMS W/(unique symbol)"

Serial Number Break - Used to list an effective serial number range where a particular part is used.

Indicated by:

"S/N XXXXX AND BELOW"

"S/N XXXX AND ABOVE"

"S/N XXXX TO S/N XXX"

Specific Model Number Use - Indicates that the part is used only with the specific model number or model number variant listed. It can also be used to show a part is NOT used on a specific model or model number variant.

Indicated by:

"XXXXX ONLY"

"NOT USED ON XXXX"

"Make/Obtain Locally" - Indicates that the part can be purchased at any hardware shop or made out of available items. Examples include battery cables, shims, and certain washers and nuts.

"Not Sold Separately" - Indicates that an item cannot be purchased as a separate item and is either part of an assembly/kit that can be purchased, or is not available for sale through Multiquip.

SUGGESTED SPARE PARTS

SS7060 SANDERS SAW

1 TO 3 UNITS WITH DEUTZ TURBO DIESEL ENGINE

Qty.	P/N	Description
1	37094	SWITCH, TOGGLE F-N-R
1	37203	SWITCH, ROLLER PLUNGER
2	406000	SWITCH, ROCKER
2	37132	FRONT WHEEL ASSEMBLY
2	37095	REAR WHEEL
1	29509	CAP, FUEL TANK
2	560017	GRIPS, HANDLEBAR
1	H9406	BULB, GE H9406
1	15503	KNOB, COMFORT
1	37311	BALL VALVE, WATER SYSTEM
2	570005	CLAMP, MUFFLER
2	37048	SPRING, WHEEL DRIVE
2	582012	BUSHING, QD
2	915316	SCREW, 5/8 - 11 X 3 LH GR8
2	915315	SCREW, 5/8 - 11 X 3 GR8
1	574003	ROPE, POINTER
1	37212	THROTTLE ASSEMBLY
2	200019	MUDFLAP, BLADEGUARD

ENGINE PARTS FOR DEUTZ TURBO DIESEL ENGINE

2	1174416	OIL FILTER, DEUTZ BF3L2012
2	304010	FUEL FILTER, DEUTZ BF3L2011
2	P772579	PRIMARY AIR FILTER ELEMENT
2	P775300	SAFETY AIR FILTER, DEUTZ BF3L2014
2	21004-003	FAN BELT, AX-35
2	520007	DRIVE BELT, 5G 3VX-530
1	406017	IGNITION SWITCH, W/KEY
2	406017-1	KEY, IGNITION
2	306006	FILTER, TRANSMISSION

FOR SAWS WITH 16", 20", AND 26" BLADEGUARDS

2	37168	FLANGE, INNER 5.0"
2	37169	FLANGE ASSEMBLY, OUTER 5.0"
2	926790	PIN, DOWEL
2	362000	HOSE, WATER #6LP (16" BLADEGUARD)
2	362005	HOSE, WATER #6LP (20" BLADEGUARD)
2	362006	HOSE, WATER #6LP (26" BLADEGUARD)

FOR SAWS WITH 30" AND 36" BLADEGUARDS

2	37177	FLANGE, INNER 6.0"
2	37176	FLANGE ASSEMBLY, OUTER 6.0"
2	926790	PIN, DOWEL
2	362007	HOSE, WATER #6LP (30" BLADEGUARD)
2	362008	HOSE, WATER #6LP (36" BLADEGUARD)



Part numbers on this Suggested Spare Parts List may supercede/replace the P/N's shown in the test pages of this manual.

NAMEPLATES AND DECALS

NAMEPLATES AND DECALS

<u>NO.</u>	<u>PART NO.</u>	<u>PART NAME</u>	<u>QTY.</u>	<u>REMARKS</u>
1	37362	DECAL, STAY LEVEL HANDLE WHITE	2	
2	20936	DECAL, MQ MULTQUIP 5.93 X 7.45	3	
3	37365	DECAL, MQ PS7060	2	
4		SERIAL TAG	1	CONTACT PARTS DEPT.
5	M600002	DECAL, DIESEL FUEL ONLY	1	
7	37161	DECAL, HOT ISO HI-TEMPERATURE	1	SAFETY ITEM
8	13118	DECAL, POWDER COATED	1	
9	20525	DECAL, WARNING "PROP 65" 3.25 X 4.25	1	SAFETY ITEM
10	36092	DECAL, WARNING DIESEL FUEL 3.5 X 1.75	1	SAFETY ITEM
11	36090	DECAL, WARNING VENTILATION 2 X 4	1	SAFETY ITEM
12	11912	DECAL, PATENT PENDING	1	
13	25282	DECAL, ATTENTION BATTERY DISCONNECTED	1	
14	35137	DECAL, WARNING READ MANUAL	1	SAFETY ITEM
15	36099	DECAL, PROTECTIVE CLOTHING ISO BLUE	1	SAFETY ITEM
16	37540	DECAL, HYDRAULIC RESERVOIR	1	
17	21302	DECAL, WARNING KEEP GUARDS IN PLACE	2	SAFETY ITEM
18	22122-001	DECAL, WARNING RX-W	2	SAFETY ITEM
19	25249-001	DECAL, WARNING KEEP HANDS CLEAR	2	SAFETY ITEM
20	25250-001	DECAL, WARNING KEEP FEET CLEAR	2	SAFETY ITEM
21	25678	DECAL, BLADE ROTATION CCW	1	SAFETY ITEM
22	23330-001	DECAL, CAUTION BELT DRIVE	2	
23	606004	DECAL, GUARD REMOVAL	2	SAFETY ITEM
24	25491	DECAL, BLADE ROTATION CW	1	
25	11092	DECAL, CE	1	

CONTROL PANEL DECALS

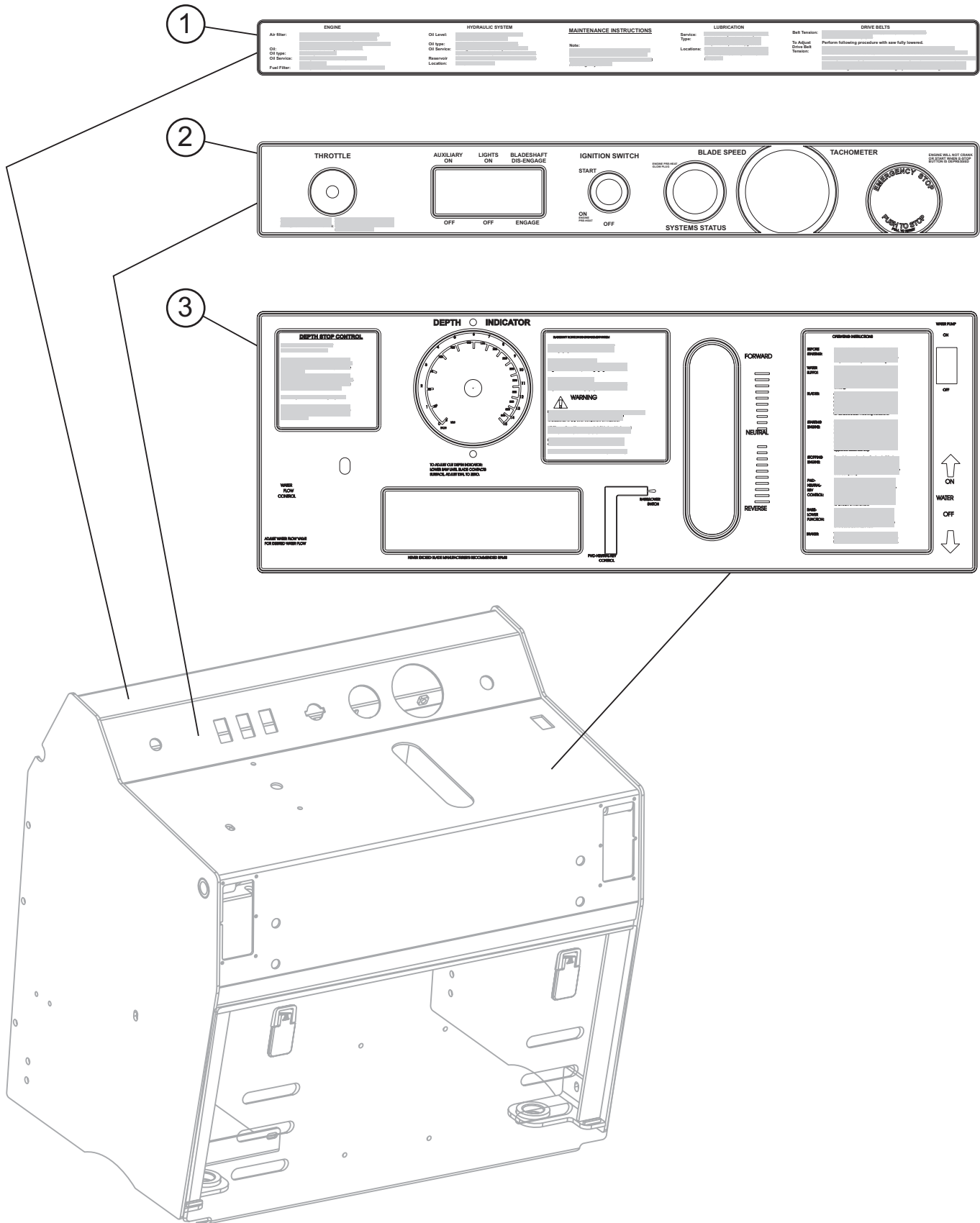

CONTROL PANEL DECALS

CONTROL PANEL DECALS

<u>NO.</u>	<u>PART NO.</u>	<u>PART NAME</u>	<u>QTY.</u>	<u>REMARKS</u>
1	37361	DECAL, MAINTENANCE, 7000 SERIES	1	
2	37354	DECAL, INSTRUMENT PANEL, 7000 SERIES	1	
3	37353	DECAL, OPERATION CONSOLE PANEL	1	

ELECTRICAL CONTROL ASSY.

ELECTRICAL CONTROL ASSY.

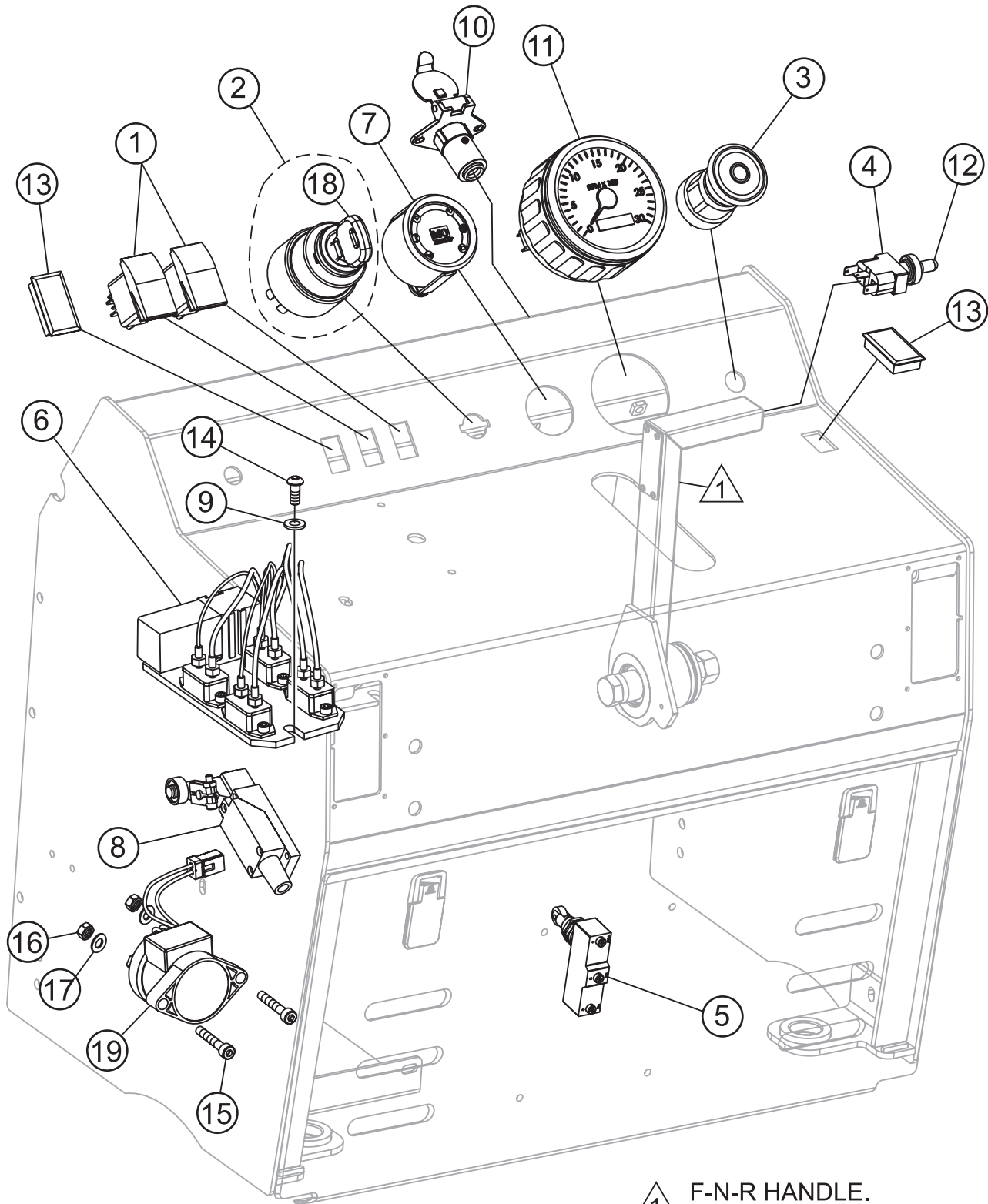

△ 1 F-N-R HANDLE.
SEE F-N-R ASSY.

ELECTRICAL CONTROL ASSY.

ELECTRICAL CONTROL ASSY.

<u>NO.</u>	<u>PART NO.</u>	<u>PART NAME</u>	<u>QTY.</u>	<u>REMARKS</u>
1	406000	SWITCH, ROCKER CH# M-58031-01	2	
2	406017	IGNITION SWITCH, WITH KEYS	1	INCLUDES ITEMS W/*
3	37198	EMERGENCY STOP SWITCH	1	SAFETY ITEM
4	37094	SWITCH, TOGGLE SPDT MOMENTARY ON-ON	1	
5	37203	SWITCH, SNAP ACTION ROLLER PLUNGER	1	
6	37490	HARNESS, RELAYS AND CIRCUIT BREAKERS	1	
7	406021	INDICATOR, ENGINE	1	
8	37243	SWITCH, ROLLER ARM	1	
9	933240	WASHER, FLAT SAE 1/4 GRD 9 YZ	3	
10	405000	CONNECTOR, 4-WAY SOCKET	1	
11	37368	TACHOMETER, ELECTRIC 0-3000 RPM	1	
12	8381	BOOT, TOGGLE SWITCH	1	
13	406020	BLANK, ROCKER SWITCH	2	
14	973752	SCREW, BHHC 1/4 - 20 X 5/8 SS	3	
15	37325	SCREW, SHC M5 - 0.8 X 30MM	2	
16	37324	NUT, NYLOC M5 - 0.8	2	
17	28922-058	WASHER, M5	2	
18*	406017-1	KEY, IGNITION	1	
19	25628	SOLENOID, LIFT PUMP	1	

CONSOLE MOUNTS ASSY.

CONSOLE MOUNTS ASSY.

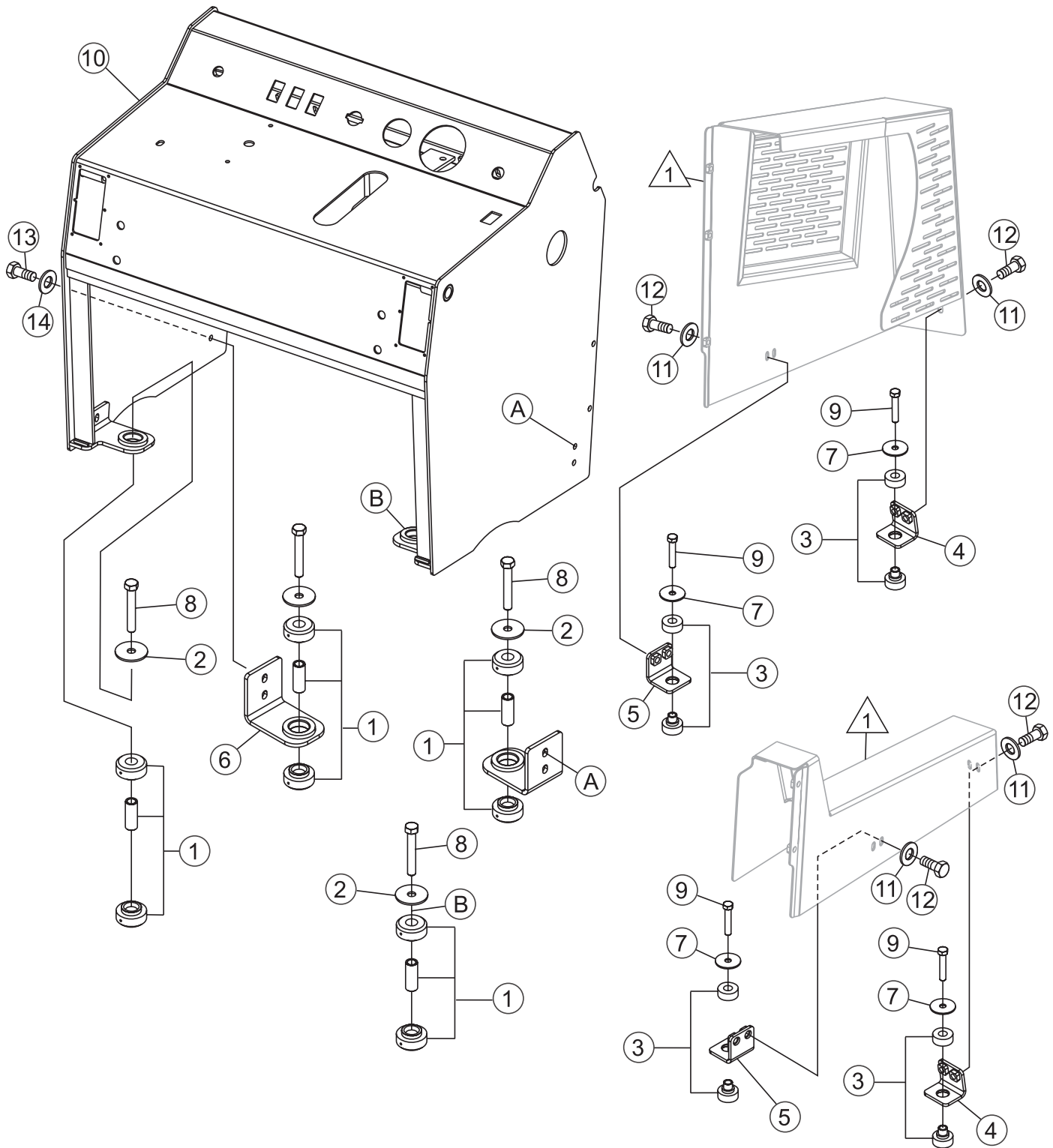

1 SEE BELT AND ENGINE GUARDS ASSY.

CONSOLE MOUNTS ASSY.

CONSOLE MOUNTS ASSY.

<u>NO.</u>	<u>PART NO.</u>	<u>PART NAME</u>	<u>QTY.</u>	<u>REMARKS</u>
1	20742	ISOLATOR, RB2 RING/BUSHING	4	
2	20743	WASHER, ISO SNUB KROFUND DYN 148099-18	4	
3	575001	RUBBER ISOLATOR, TPC# 60166-1	4	
4	37231-353	MOUNT, ISOLATOR FRONT	2	
5	37233-353	MOUNT, ISOLATOR SIDE	2	
6	37227-353	MOUNT, CONSOLE ISOLATOR FRONT	2	
7	12832	WASHER, SNUBBING	4	
8	06503-026	SCREW, HHC 1/2 - 13 X 3-1/4	4	
9	1665	SCREW, HHC 3/8 - 16 X 2	4	
10	37116-353	CONSOLE W/A	1	
11	933242	WASHER, FLAT SAE 3/9 GRD 9 Y	8	
12	0205	SCREW, HHC 3/8-16 X 1	8	
13	TBD	SCREW	4	
14	TBD	WASHER	4	

REAR CONSOLE ACCESS PANEL ASSY.

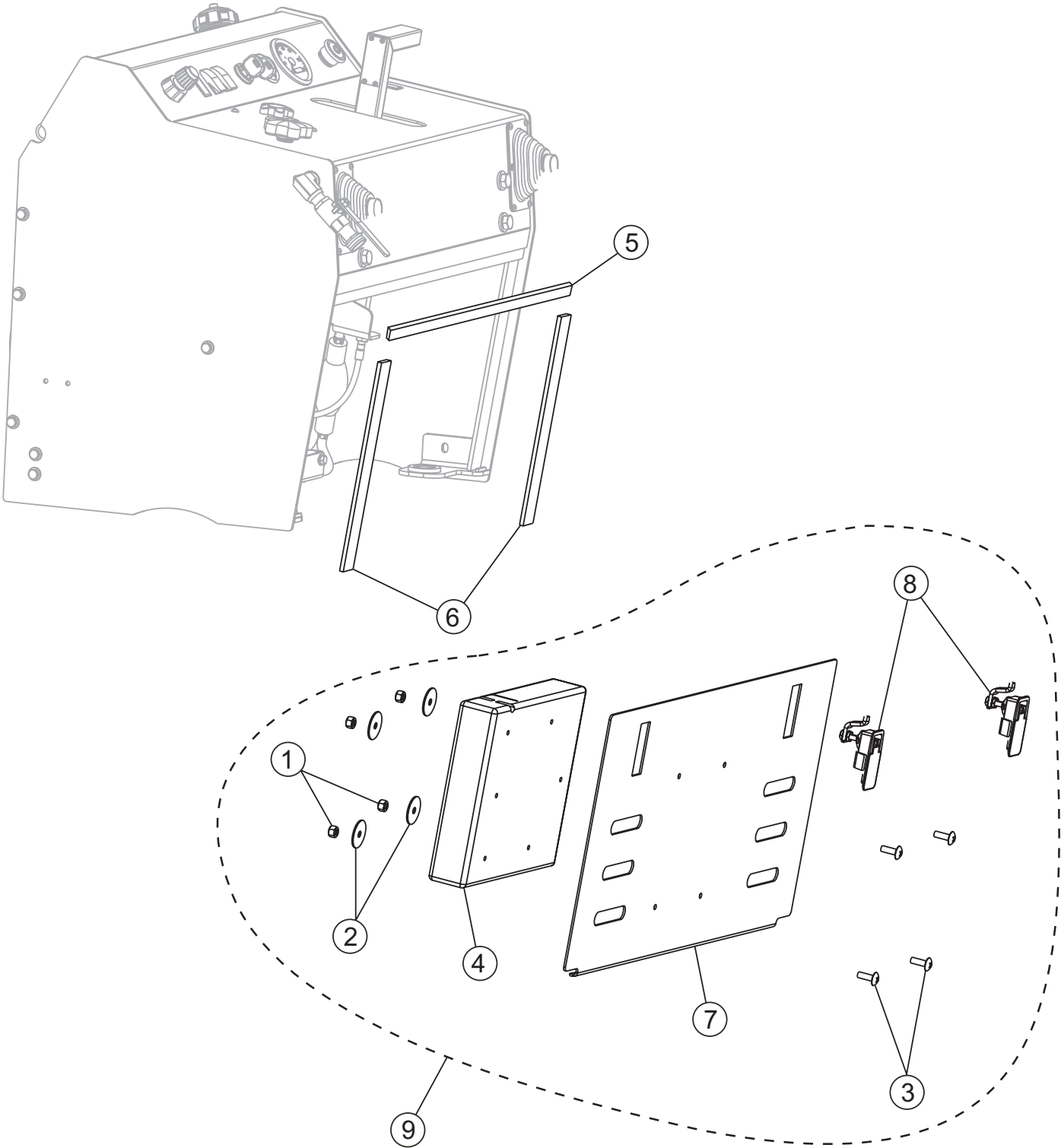

REAR CONSOLE ACCESS PANEL ASSY.

REAR CONSOLE ACCESS PANEL ASSY.

<u>NO.</u>	<u>PART NO.</u>	<u>PART NAME</u>	<u>QTY.</u>	<u>REMARKS</u>
1*	10024	NUT, NYLOC 1/4 X 20	4	
2*	10930	WASHER, FENDER 1/4 X 1-1/4	4	
3*	12287	SCREW, THP 1/4 - 20 X 3/4 SS	4	
4*	29057	DOCUMENT BOX	1	
5	37219	STRIP, BACKING PLATE SAW CONSOLE	1	
6	37220	STRIP, VERTICAL SAW CONSOLE	2	
7*	37254-353	PANEL, REAR SAW ACCESS	1	
8*	560020	LATCH, REAR SAW ACCESS PANEL	2	
9	37253	PANEL ASSEMBLY, REAR SAW ACCESS	1	INCLUDES ITEMS W/*

LIGHT CONNECTOR/DASH ACCESS ASSY.

LIGHT CONNECTOR/DASH ACCESS ASSY.

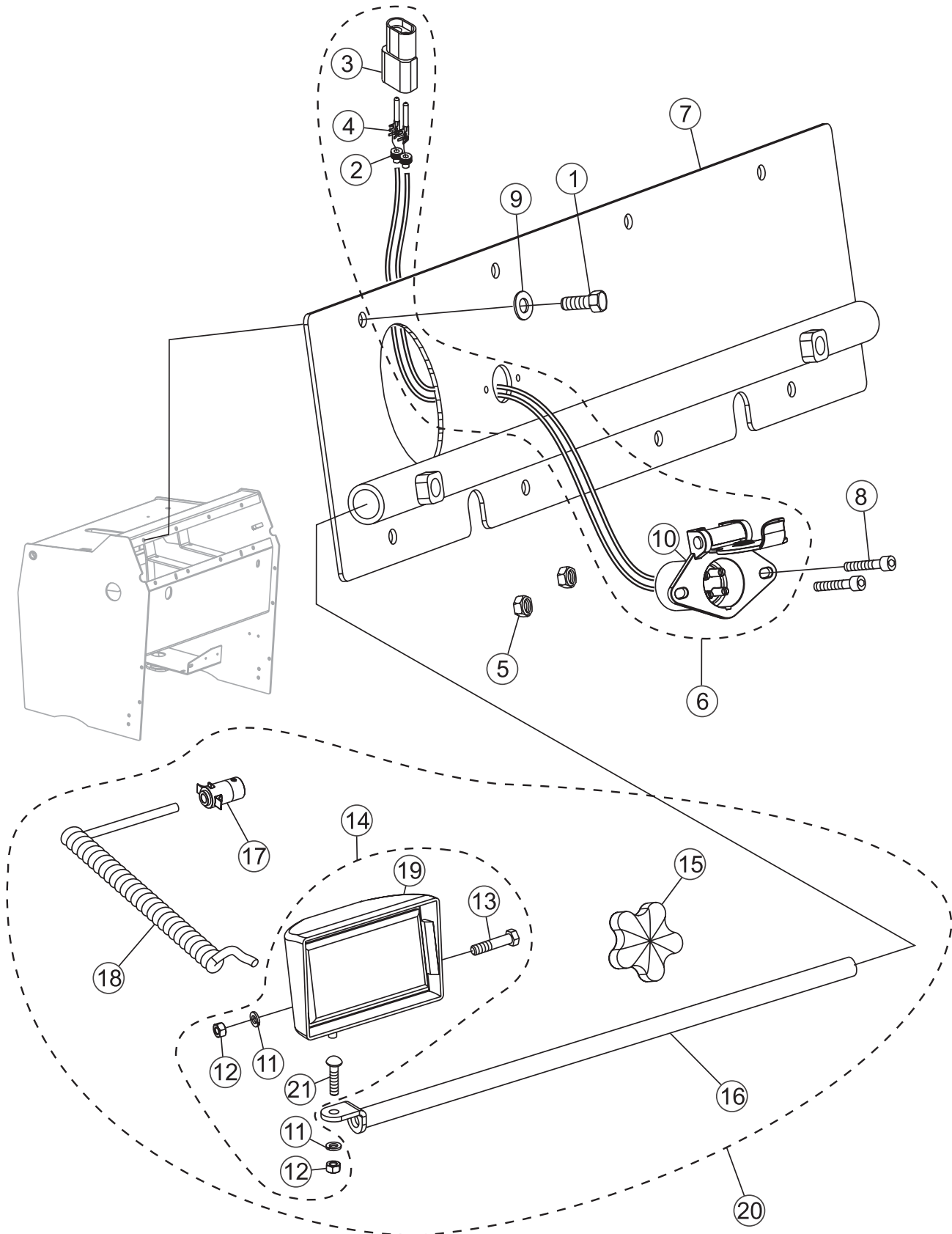

LIGHT CONNECTOR/DASH ACCESS ASSY.

LIGHT CONNECTOR/DASH ACCESS ASSY.

<u>NO.</u>	<u>PART NO.</u>	<u>PART NAME</u>	<u>QTY.</u>	<u>REMARKS</u>
1	0655	SCREW, HHC 5/16 - 18 X 3/4	8	
2*	12171	SEAL, WEATHERPACK 16-18 GA, GREEN	2	
3*	12176	CONNECTOR, WEATHERPACK 2 PIN MALE	1	
4*	12179	TERMINAL, WEATHERPACK MALE 14-16 GA	2	
5	13287	NUT, NYLOC 8-32	2	
6	25865	HARNESS, LIGHT KIT	1	INCLUDES ITEMS W/*
7	37234-353	COVER W/A, CONSOLE DASH ACCESS	1	
8	923114	SCREW, SHC 8-32 X 1/2	2	
9	933241	WASHER, FLAT SAE 5/16 GRD 9YZ	8	
10*	405000	CONNECTOR, 4-WAY SOCKET CHROME	1	
11+#	0161 C	WASHER, LOCK 5/16 MED	2	
12+#	0161 D	NUT, HEX 5/16 - 18	2	
13+#	0300 A	SCREW, HHC 5/16 - 18 X 2	1	
14+	2532	LIGHT ASSEMBLY	1	INCLUDES ITEMS W/#
15+	15503	KNOB, COMFORT GRIP STAR	1	
16+	120206	LIGHT BAR	1	
17+	405001	CONNECTOR PLUG, 4-PIN FEMALE	1	
18+	405002	CORD, LIGHT EXTENDABLE	1	
19+#	H9406	BULB, GE H9406	1	
20	M18004	LIGHT KIT, SAW	1	INCLUDES ITEMS W/+
21#	11963	BOLT, CARRIAGE 5/16 - 18 X 1	1	

BELT AND ENGINE GUARDS ASSY.

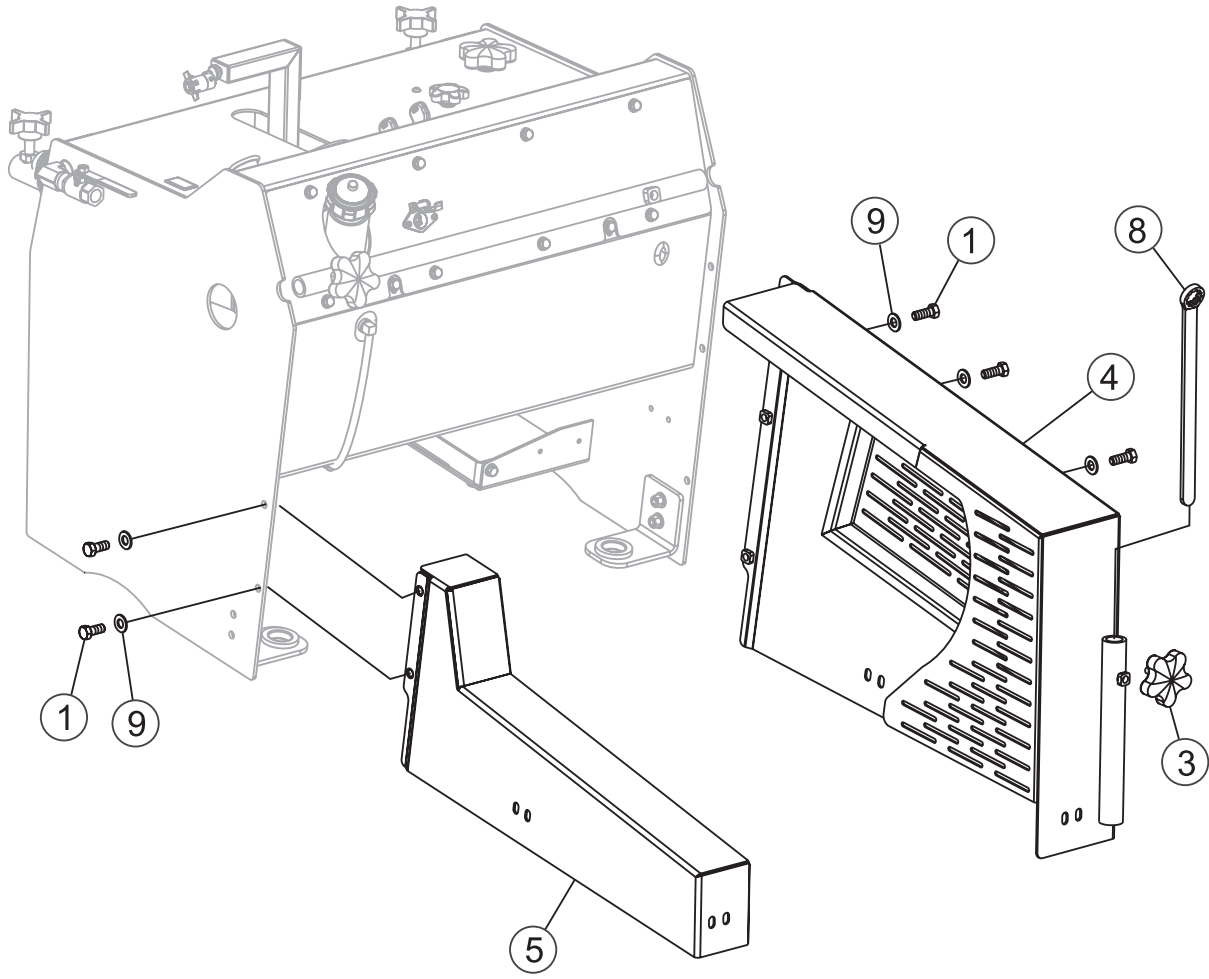

BELT AND ENGINE GUARDS ASSY.

BELT AND ENGINE GUARDS ASSY.

<u>NO.</u>	<u>PART NO.</u>	<u>PART NAME</u>	<u>QTY.</u>	<u>REMARKS</u>
1	0166	SCREW, HHC 3/8 - 16 X 7/8	5	
3	15503	KNOB, COMFORT	1	
4	37202-353	GUARD, BELT DRIVE	1	SAFETY ITEM
5	37209-353	GUARD, ENGINE	1	SAFETY ITEM
8	584011	WRENCH, 15/16 BLADE CLOSED END	1	
9	933242	WASHER, FLAT SAE 3/8 GRD 9 YZ	5	

DEPTH INDICATOR/STOP SWITCH ASSY. (OLD STYLE)

DEPTH INDICATOR/STOP SWITCH ASSY. (OLD STYLE)

<u>NO.</u>	<u>PART NO.</u>	<u>PART NAME</u>	<u>QTY.</u>	<u>REMARKS</u>
1	10024	NUT, NYLOC 1/4 - 20	2	
2	37155	PULLEY, CABLE .75 OD	1	
3	37235	BASE, SAW DEPTH INDICATOR	1	
4	37240	PULLEY, CABLE .75 OD	2	
5	37241	SHAFT, DEPTH INDICATOR	1	
6	37332	RING, 3/16 E-STYLE EXTERNAL	2	
7	37401	SCREW, SH SHLDR 1/2-20, 5/16 OD X 1/4 L	1	
8	37504	CABLE, NYLON COAT SS .049	1	
9	110031	POINTER, CONCRETE SAW DEPTH	1	
10	460019	FLANGE, BEARING 0.25 ID X 0.75 OD	1	
11	560025	KNOB, SAW DEPTH INDICATOR	1	
12	565005	SPRING, EXTENSION	1	
13	583059	SHIM, 0.375 OD X 0.25 ID X .020 THK	5	
14	584025	STUD, 1/4 - 20 X 1-3/4 NO PLT	1	
15	933240	WASHER, FLAT SAE 1/4 GRD 9 YZ	1	
16	973752	SCREW, BHSC 1/4 - 20 X 5/8 SS	2	
17	37248	MOUNT, SWITCH PIVOT PLATE	1	
18	37246	NUT, SWIVEL DEPTH STOP	1	
19	37247	KNOB, DEPTH STOP CONTROL	1	
20	37249	COLLAR, SHAFT THREADED 3/8 - 16	1	
21	37250	WASHER, BELLEVIEW .317 X .625	2	
22	19470	WASHER, FLAT 5/16 USS	2	
23	933242	WASHER, FLAT SAE 3/8 GRD 9 YZ	1	
24	5283	NUT, NYLOC 5/16 - 18	2	
25	10133	NUT, NYLOC 3/8 - 16	1	
26	37251	WASHER, BELLEVIEW .389 X .750	2	
27	37375	STUD, 3/8 - 16 X 4	1	
28	4001	WASHER, FLAT USS 3/8 PLD	3	



PARTS ON THIS PAGE ARE NO LONGER AVAILABLE. SEE DEPTH INDICATOR/STOP SWITCH ASSY. (NEW STYLE)

DEPTH INDICATOR/STOP SWITCH ASSY. (NEW STYLE)

DEPTH INDICATOR/STOP SWITCH ASSY. (NEW STYLE)

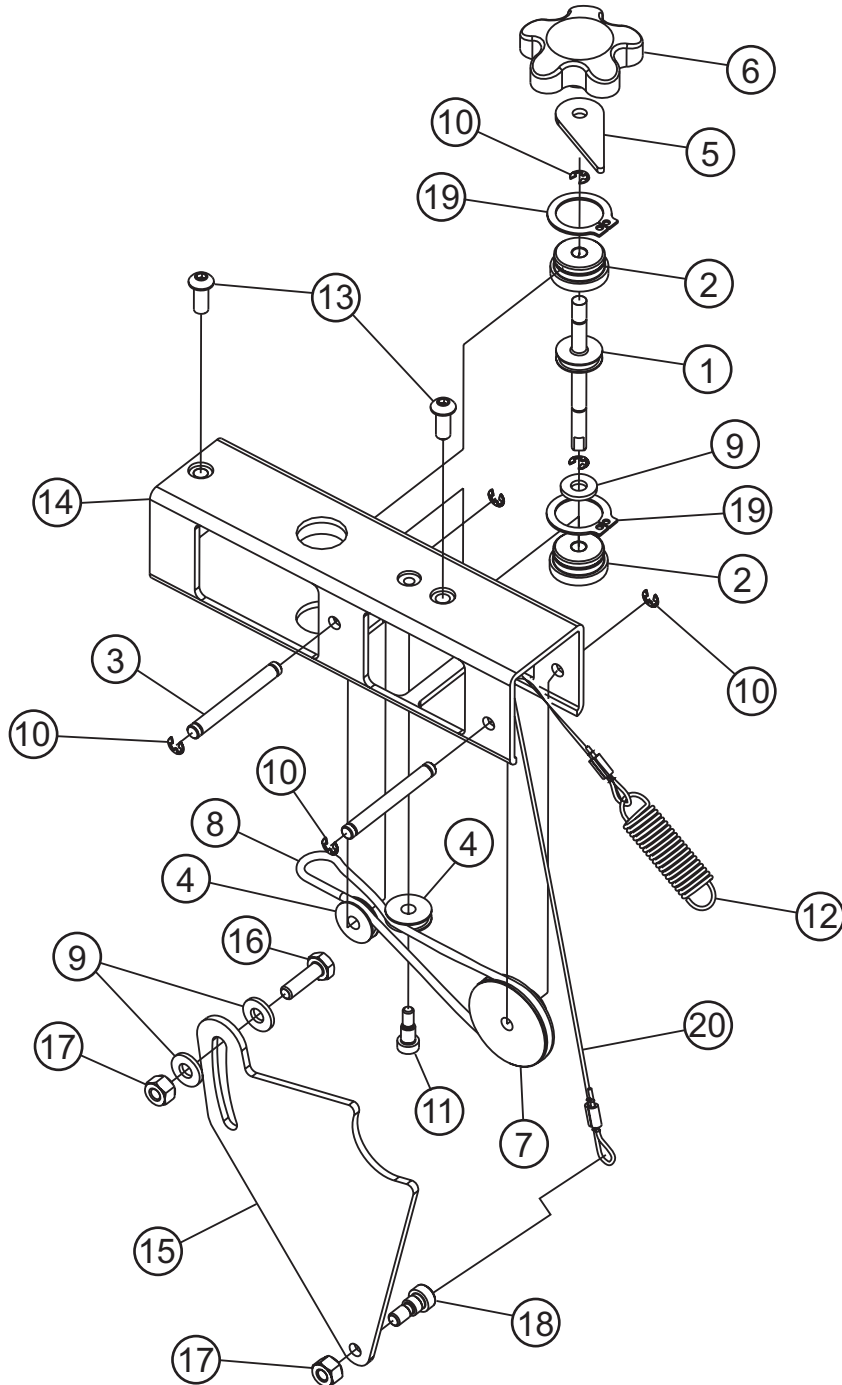

DEPTH INDICATOR/STOP SWITCH ASSY. (NEW STYLE)

DEPTH INDICATOR/STOP SWITCH ASSY. (NEW STYLE)

<u>NO.</u>	<u>PART NO.</u>	<u>PART NAME</u>	<u>QTY.</u>	<u>REMARKS</u>
1	37544	SHAFT, DEPTH INDICATOR	1	
2	37545	BUSHING, FLANGED	2	
3	37547	SHAFT, IDLER PULLEY	2	
4	37548	PULLEY, IDLER	2	
5	110031	POINTER, CONCRETE SAW DEPTH	1	
6	560025	KNOB, SAW DEPTH INDICATOR	1	
7	37549	PULLEY, DUAL GROOVE	1	
8	37550	BELT, INDICATOR DRIVE	1	
9	0948	WASHER, FLAT SAE 1/4	3	
10	37332	RING, 3/16 E-STYLE EXTERNAL	6	
11	926149	SCREW, SHDLR 1/4D X 5/16L, 10-24 SCKT HD	1	
12	37162	SPRING, EXTENSION	1	
13	973752	SCREW, BHSC 1/4 - 20 X 5/8 SS	2	
14	37551	HOUSING, DEPTH INDICATOR	1	
15	37557	BRACKET, CABLE INDICATOR	1	
16	2295	SCREW, HHC 1/4 - 20 X 7/8	1	
17	10024	NUT, NYLOC 1/4 - 20	2	
18	37401	SCREW, SH SHLDR 1/2-20, 5/16 OD X 1/4 L	1	
19	37679	RING, SNAP SH 87	2	
20	37678	CABLE ASSY., DEPTH INDICATOR	1	

F-N-R ASSY.

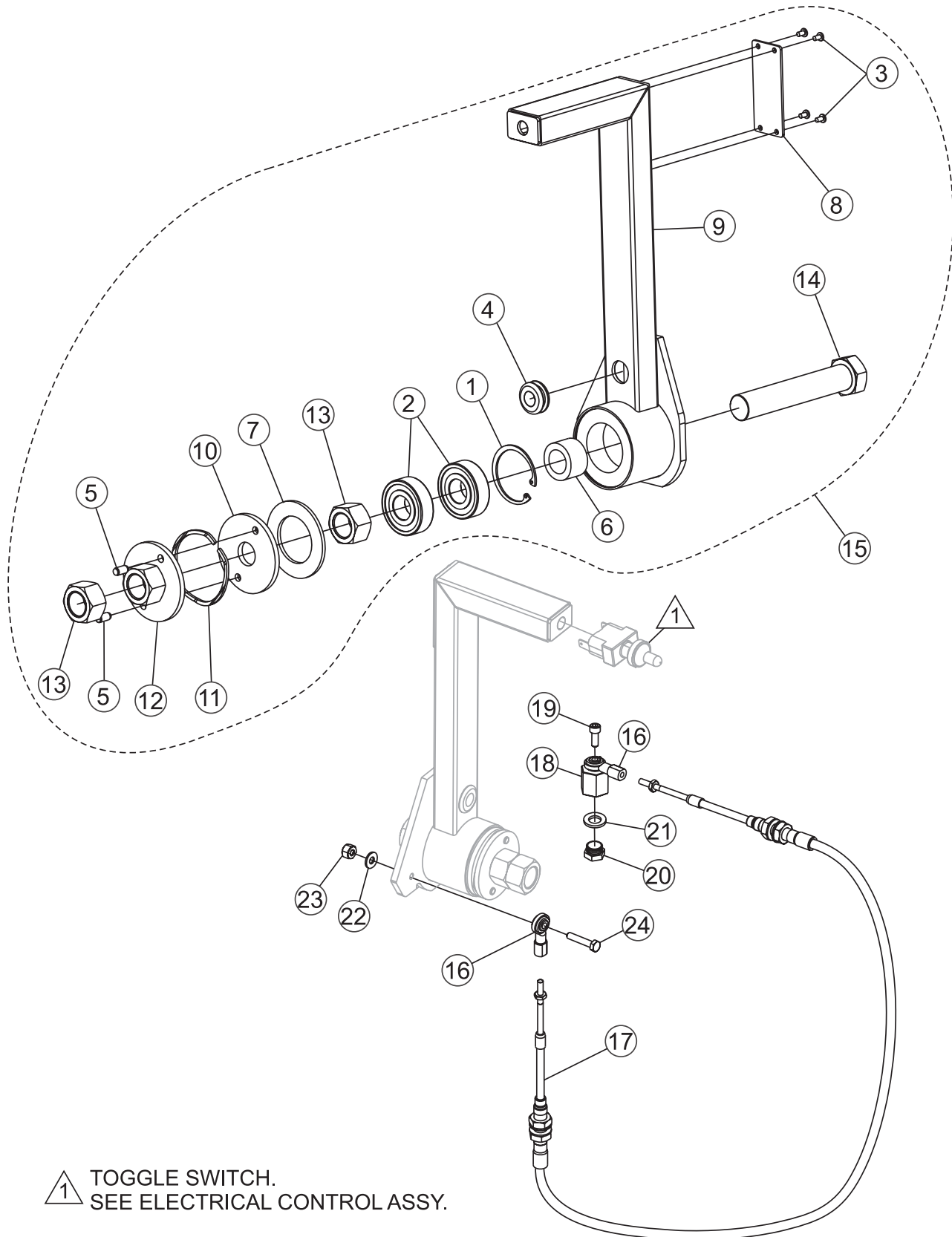

1 TOGGLE SWITCH.
SEE ELECTRICAL CONTROL ASSY.

F-N-R ASSY.

<u>NO.</u>	<u>PART NO.</u>	<u>PART NAME</u>	<u>QTY.</u>	<u>REMARKS</u>
1*	576003	SNAP RING - HO-185	1	
2*	460021	BEARING, ROLLER # 6204 2RS	2	
3*	20842	SCREW, PAN HD 6-32 X 1/4	4	
4*	579072	GROMMET, 1/2" ID	1	
5*	926917	PIN, DOWEL 1/4 X 1/2	2	
6*	37015	SPACER, FNR PIVOT	1	
7*	37014	DISC, FNR FRICTION BRAKE	1	
8*	37013	PLATE, FNR ACCESS COVER	1	
9*	37022	WELDMENT, FNR HANDLE	1	
10*	37016	PLATE, FNR BRAKE	1	
11*	37091	SPRING, SMALLEY WAVO RW-0250	1	
12*	37024	WELDMENT, FNR SPRING PLATE	1	
13*	37025	NUT, HEX FINISH M20-2.5	2	
14*	37026	SCREW, HHC M20 X 2.5 X 120	1	
15	37021	FNR ASSEMBLY	1	INCLUDES ITEMS W/*
16	2153	ROD END	2	
17	37136	CABLE, PUSH PULL 56"	1	
18	37299	STANDOFF, PUMP CONTROL	1	
19	07469-004	SCREW, SHC 10-32 X 1/2	1	
20	4683	SCREW, HHC 5/16 - 18 X 5/8	1	
21	933241	WASHER, FLAT SAE 5/16 GRD 9 YZ	1	
22	2203	WASHER, FLAT #10	1	
23	10019	NUT, NYLOC 10-32	1	
24	3513	SCREW, HHC 10 - 32 X 1	1	

FUEL ASSY.

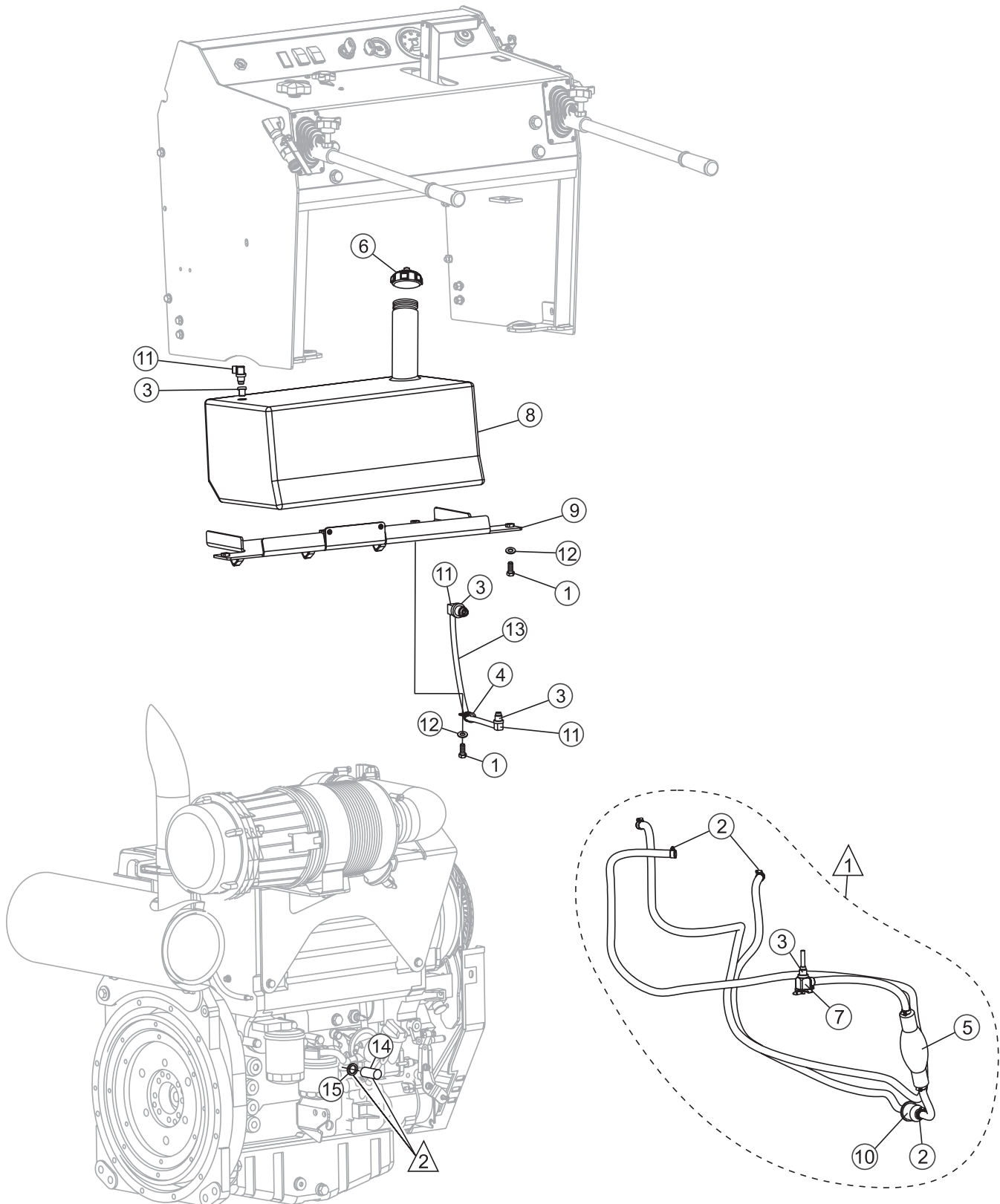

▲ 1 S/N ZC3700225 AND BELOW

▲ 2 S/N ZC3700226 AND ABOVE

FUEL ASSY.

<u>NO.</u>	<u>PART NO.</u>	<u>PART NAME</u>	<u>QTY.</u>	<u>REMARKS</u>
1	0205	SCREW, HHC 3/8 - 16 X 1.0	5	
2	19473	CLAMP, WORM HOSE 2"	8	S/N ZC3700225 AND BELOW
3	19633	BUSHING, RUBBER FUEL DAPCO	4	
4	35022	CLAMP, LOOP CUSHIONED #8	1	
5	29338	PRIMER BULB 5/16 HOSE BARB	1	S/N ZC3700225 AND BELOW
6	29509	CAP, FUEL TANK	1	
7	37128	BALL VALVE, 90 W/SCREEN #5	1	S/N ZC3700225 AND BELOW
8	37191	FUEL TANK	1	
9	37195-353	MOUNT, FUEL TANK	1	
10	37809	FILTER, FUEL DEUTZ IN-LINE	1	S/N ZC3700225 AND BELOW
11	368006	FITTING, FUEL 90 DEG	3	
12	933242	WASHER, FLAT SAE 3/8 GRD 9 YZ	5	
13	60058	HOSE, 1/4 X 3/8 PVC YELLOW	1.2	SOLD BY FOOT
14	2111897	HAND PUMP, INTEGRATED	1	S/N ZC3700226 AND ABOVE
15	1287773	O-RING SEAL	1	S/N ZC3700226 AND ABOVE

BATTERY ASSY.

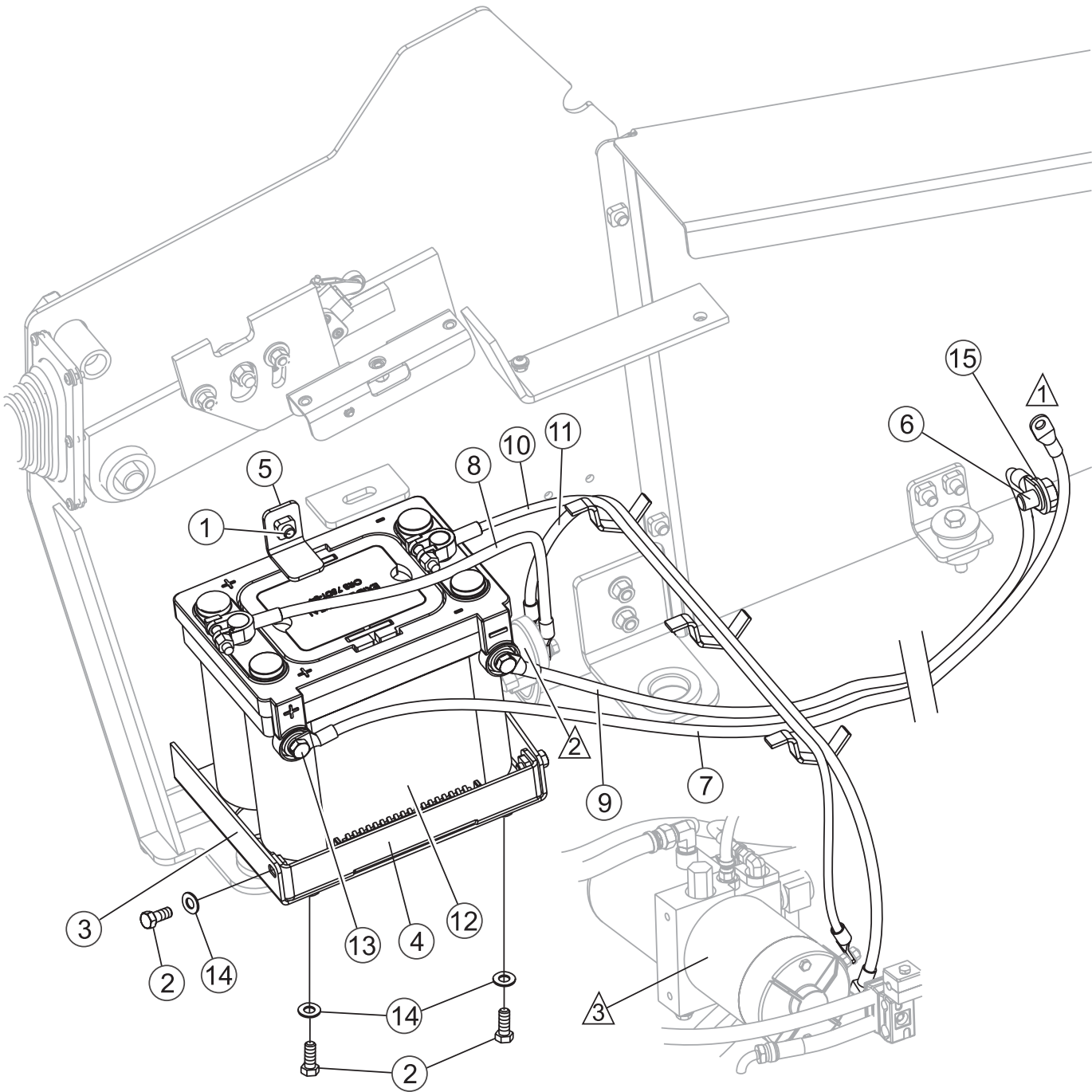

△1 TO ENGINE STARTER MOTOR

△2 LIFT PUMP SOLENOID (RELAY).
SEE ELECTRICAL CONTROL ASSY.

△3 LIFT PUMP.
SEE HYDRAULIC SYSTEM ASSY.

BATTERY ASSY.

BATTERY ASSY.

<u>NO.</u>	<u>PART NO.</u>	<u>PART NAME</u>	<u>QTY.</u>	<u>REMARKS</u>
1	0166	SCREW, HHC 3/8 - 16 X 7/8	1	
2	0655	SCREW, HHC 5/16 - 18 X 3/4	4	
3	37088	BOX, BATTERY	1	
4	37098	RETAINER, BATTERY HOLD-DOWN	1	
5	37258-353	CLIP, BATTERY RETAINER	1	
6	37284	SCREW, HHC M14 - 2.0 X 20MM GRD 8.8 PLTD	1	
7	37326	CABLE, POSITIVE BATTERY STARTER	1	
8	37327	CABLE, POSITIVE BATT. SOLENOID LIFT PUMP	1	
9	37328	CABLE, NEGATIVE BATTERY ENGINE	1	
10	37329	CABLE, NEGATIVE BATTERY LIFT PUMP	1	
11	37355	CABLE, POSITIVE BATT. SOLENOID LIFT PUMP	1	
12	404006	BATTERY, EXIDE ORB75DT-84	1	
13	915101	SCREW, HHC 3/8 - 16 X 1/2 GRD 8	2	
14	933241	WASHER, FLAT SAE 5/16 GRD 9 YZ	4	
15	933245	WASHER, FLAT SAE 9/16 GRD 9 YZ	1	

STAY-LEVEL HANDLEBARS ASSY.

STAY-LEVEL HANDLEBARS ASSY.

<u>NO.</u>	<u>PART NO.</u>	<u>PART NAME</u>	<u>QTY.</u>	<u>REMARKS</u>
1	37085	BEARING, 1.25" TAP BASE	1	
2	37239	SHAFT, CROSSDRIVE SLH	1	
3	37119	RECEIVER, SLH HANDLEBAR LH	1	
4	37120	RECEIVER, SLH HANDLEBAR RH	1	
5	37125	BEARING, PLAIN 1.0625 ULTRASERT UC200	2	
6	560023	HANDLEBAR ASSY., CONCRETE SAW	2	INCLUDES ITEMS W/*
7	37174	LINK ASSY., SLH CONTROL COUPLER	1	INCLUDES ITEMS W/#
8	37139	SLH CONTROL LEVER	1	
9	16523	SCREW, HHC 3/4 - 10 X 1-1/2 GD 8	3	
10	933245	WASHER, FLAT SAE 9/16 GRD 9 YZ	4	
11	933247	WASHER, FLAT SAE 3/4 GRD 9 YZ	3	
12	37284	SCREW, HHC M14-2.0 X 20MM GRD 8.8 PLTD	4	
13	37312	RING, RETAINING WHM-106	2	
14	19977	KNOB, CLAMP 1/2 - 13 THREAD	2	
15#	37123	LINK, SLH CONTROL COUPLER LOWER	1	
16#	37173	LINK, SLH CONTROL COUPLER UPPER	1	
17#	37297	PLATE, SLH CLAMP	1	
18#	16526	SCREW, HHC 1/2 - 13 X 1-3/4 GRD 8	2	
19	4196	SCREW, HHC 3/8 - 16 X .75	2	
20#	933244	WASHER, FLAT SAE 1/2 GRD 9 YZ	2	
21	4001	WASHER, FLAT USS 3/8 PLD	2	
22	37133	PIN, SLH COUPLER PIVOT	2	
23*	560017	GRIP, HANDLEBAR	2	

HANDLEBAR BOOT ASSY.

HANDLEBAR BOOT ASSY.

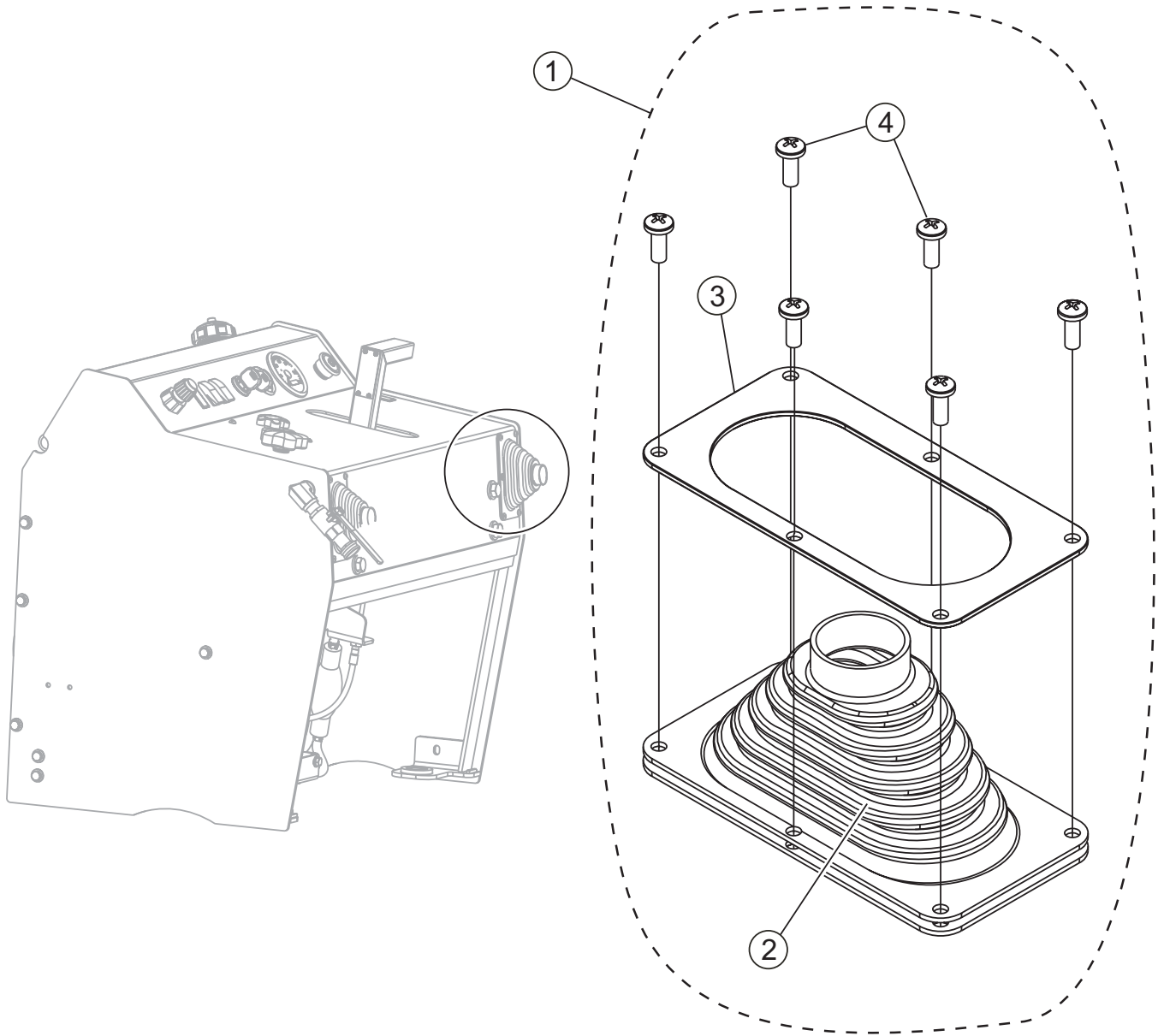

HANDLEBAR BOOT ASSY.

HANDLEBAR BOOT ASSY.

<u>NO.</u>	<u>PART NO.</u>	<u>PART NAME</u>	<u>QTY.</u>	<u>REMARKS</u>
1	37117	BOOT ASSY., HANDLEBAR	1	INCLUDES ITEMS W/*
2*	37105	BOOT, SLH HANDLEBAR	1	
3*	37061	PLATE, RETAINER	1	
4*	5065 B	SCREW, PHP 10 - 32 X 1/2	6	

WATER SYSTEM ASSY.

WATER SYSTEM ASSY.

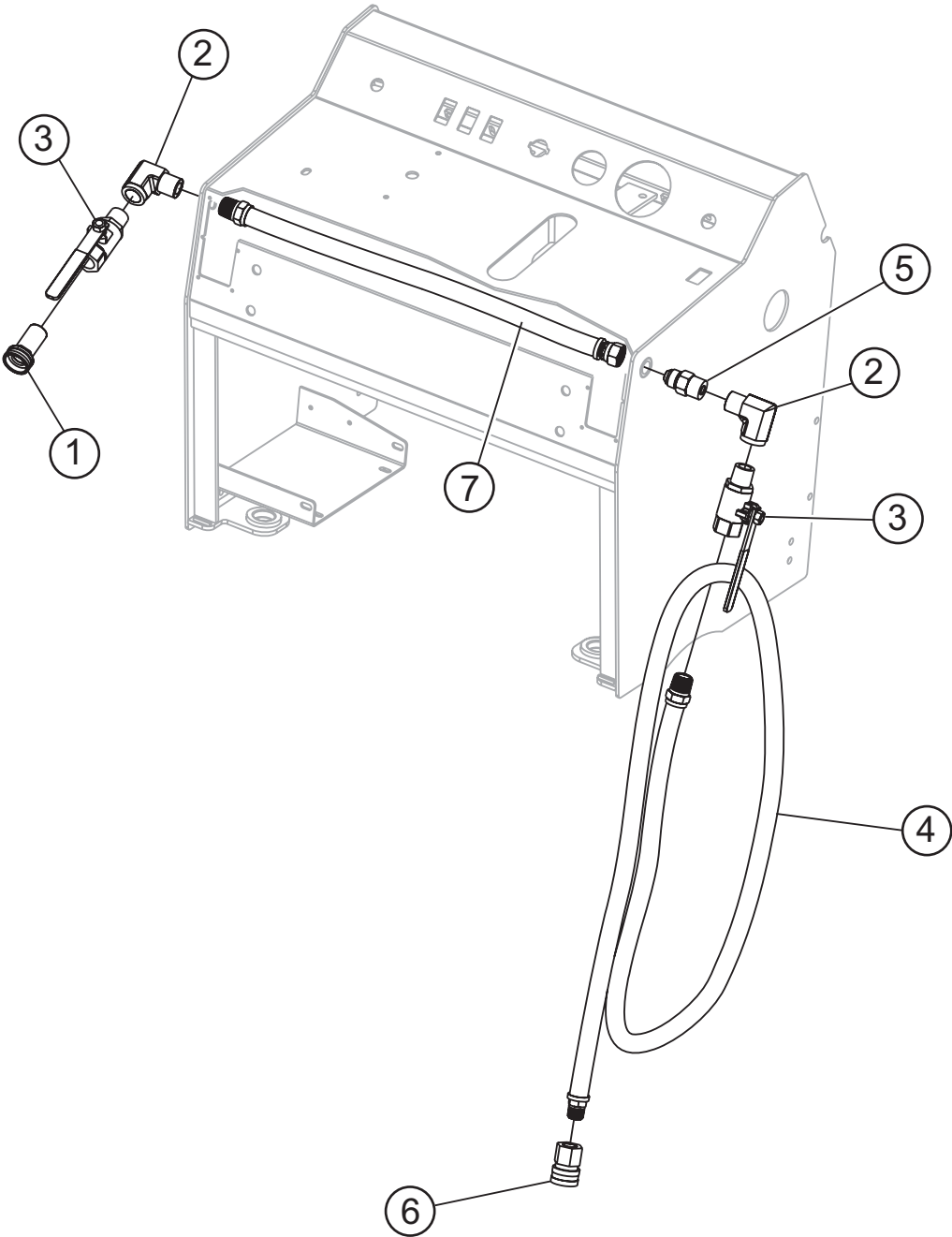

WATER SYSTEM ASSY.

WATER SYSTEM ASSY.

<u>NO.</u>	<u>PART NO.</u>	<u>PART NAME</u>	<u>QTY.</u>	<u>REMARKS</u>
1	25827	FITTING, BRASS (F) 3/4 GHT SWIVEL 1/2 MNPT	1	
2	37813	FITTING, 90 1/2MP - 3/8FP	2	
3	37311	BALL VALVE, BRASS 3/8 MNPT X FNPT	2	
4	37533	HOSE ASSEMBLY, WATER SYSTEM 76.5"	1	
5	37397	FITTING, 8MJ X 1/2 MP	1	
6	37532	FITTING, QC FEMALE	1	
7	37296	HOSE ASSEMBLY, CROSSOVER	1	

ENGINE ASSY.

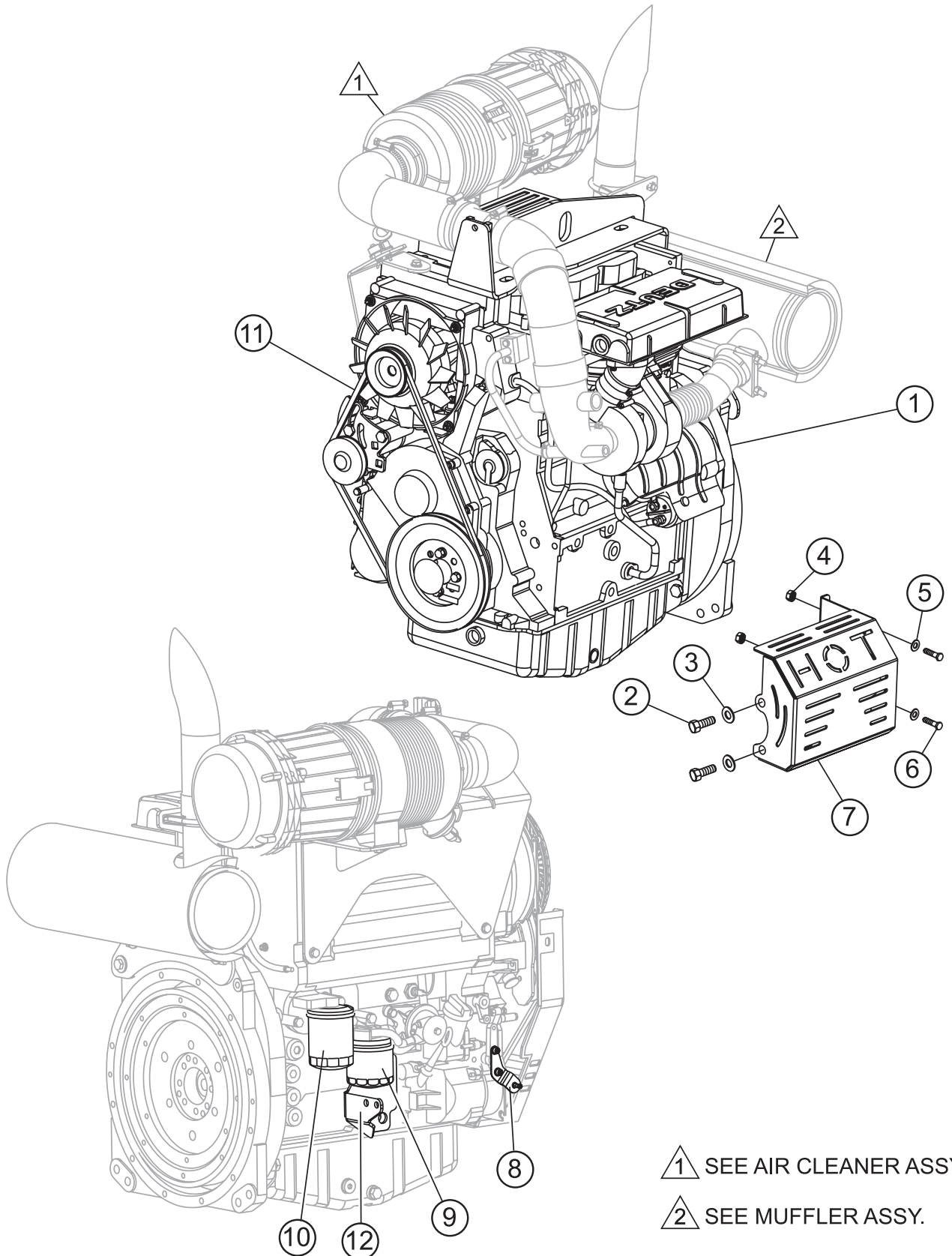

① SEE AIR CLEANER ASSY.

② SEE MUFFLER ASSY.

ENGINE ASSY.

ENGINE ASSY.

<u>NO.</u>	<u>PART NO.</u>	<u>PART NAME</u>	<u>QTY.</u>	<u>REMARKS</u>
1	35396	ENGINE, DEUTZ 60HP BF3L2011 TRBO DSL	1	
2	2299	SCREW, HHC M8 - 1.25 X 16MM	2	
3	933241	WASHER, FLAT SAE 5/16 GRD 9 YZ	2	
4	10024	NUT, NYLOC 1/4 X 20	2	
5	933240	WASHER, FLAT SAE 1/4 GR 9 YZ	2	
6	915004	SCREW, HHC 1/4 - 20 X 7/8	2	
7	37473	HEAT SHIELD	1	SAFETY ITEM
8	37255	THROTTLE LEVER	1	
9	1174696	FILTER, FUEL DEUTZ	1	REPLACES 304010
10	1174416	FILTER, OIL DEUTZ	1	REPLACES 306012
11	21004-003	V-BELT, AX-35	1	
12	37256	BRACKET, THROTTLE/FNR CABLE	1	

THROTTLE CONTROL ASSY.

THROTTLE CONTROL ASSY.

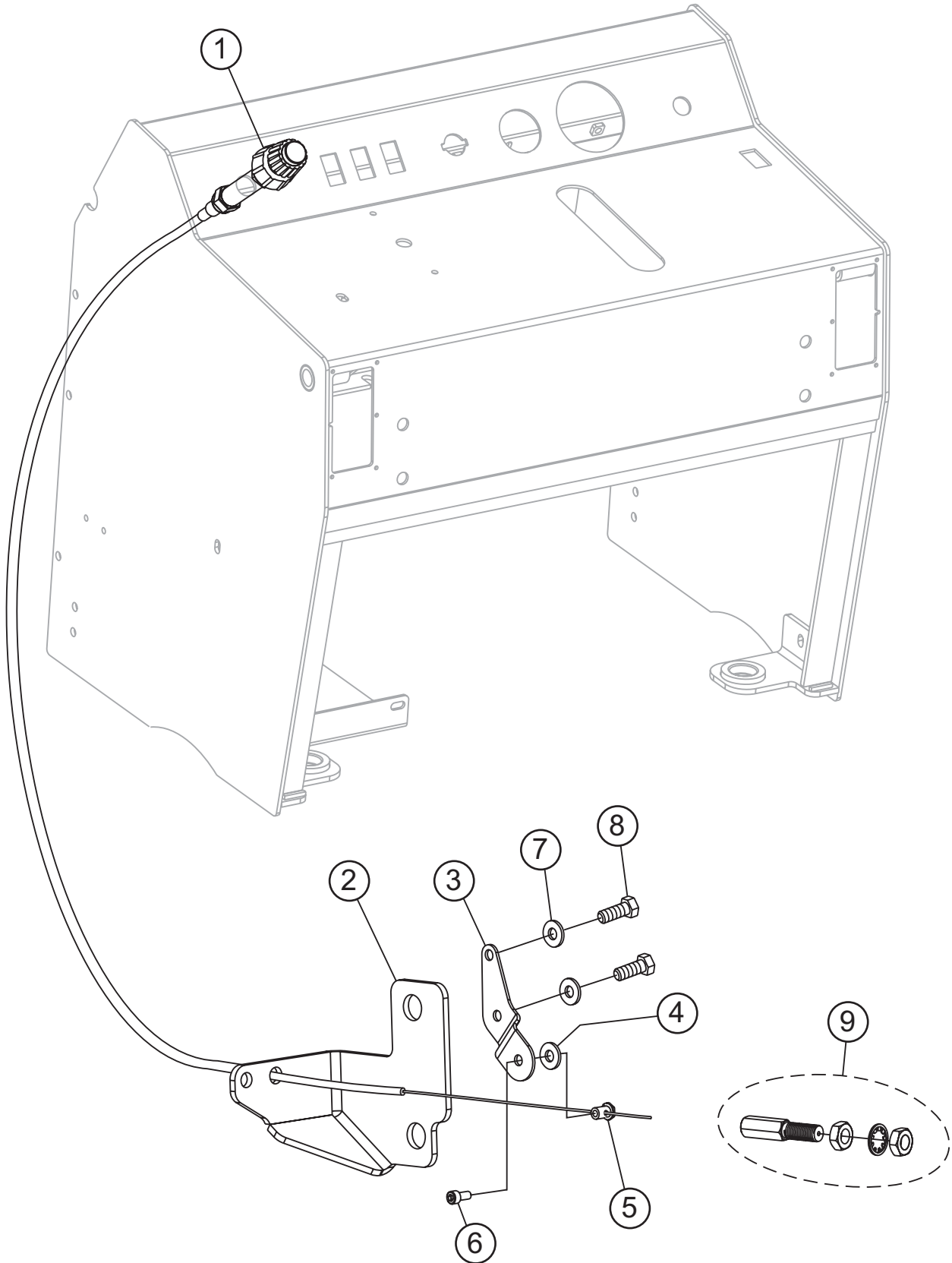

THROTTLE CONTROL ASSY.

THROTTLE CONTROL ASSY.

<u>NO.</u>	<u>PART NO.</u>	<u>PART NAME</u>	<u>QTY.</u>	<u>REMARKS</u>
1	37212	THROTTLE	1	
2	37256	BRACKET, THROTTLE/FNR CABLE	1	
3	37255	LEVER, THROTTLE	1	
4	933240	WASHER, FLAT SAE 1/4 GRD 9 YZ	1	
5	25624	SWIVEL, CABLE END W/ WASHER	1	
6	923113	SCREW, SHC 8 - 32 X 3/8 GRD 8	1	
7	23942-097	WASHER, M6	2	
8	12464	SCREW, HHC M6 - 1.0 X 16MM	2	
9	25634	BULK HEAD ADAPTOR	1	

ENGINE MOUNTS ASSY.

ENGINE MOUNTS ASSY.

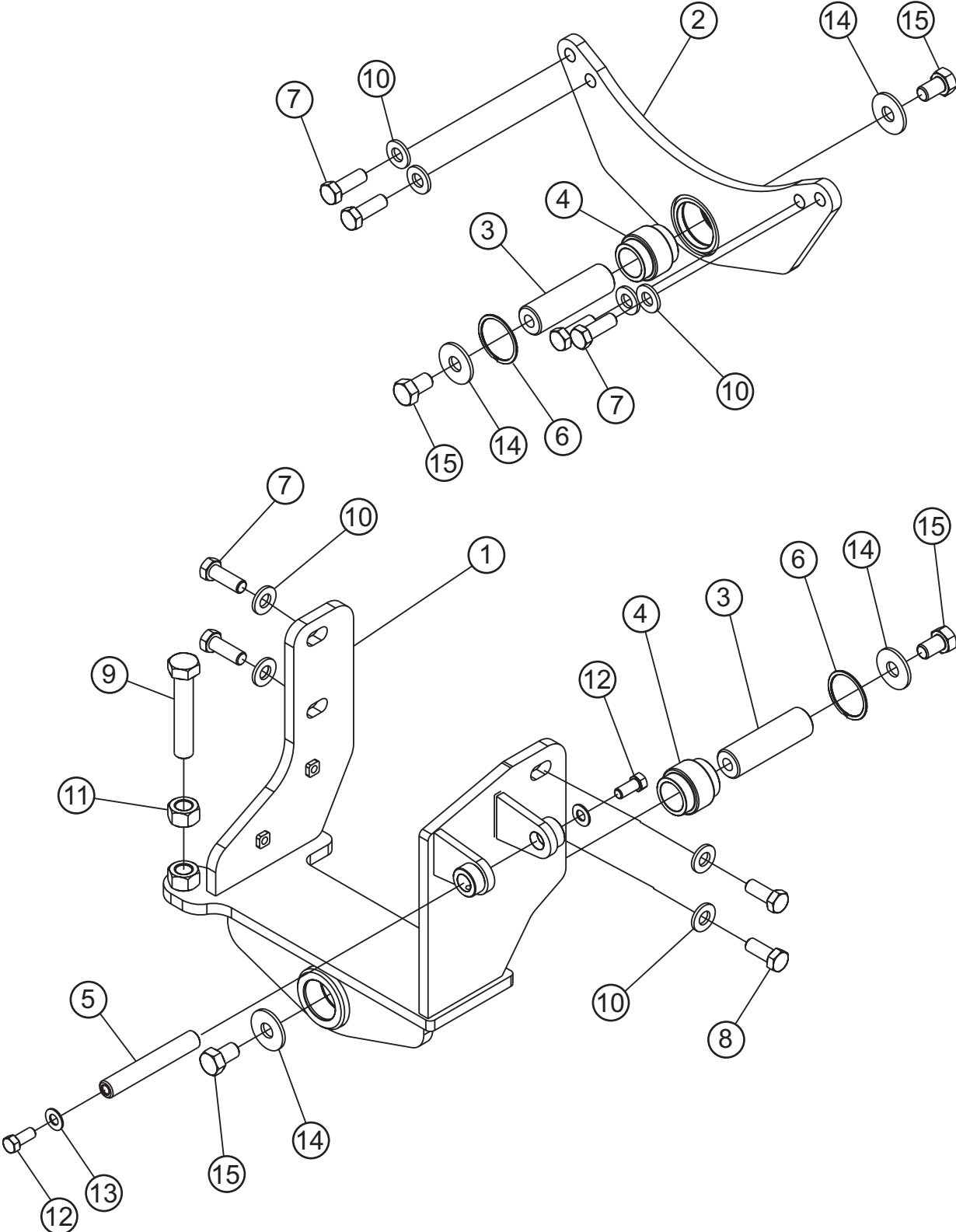

ENGINE MOUNTS ASSY.

ENGINE MOUNTS ASSY.

<u>NO.</u>	<u>PART NO.</u>	<u>PART NAME</u>	<u>QTY.</u>	<u>REMARKS</u>
1	37491	MOUNT, RH ENGINE	1	
2	37100	MOUNT, LH ENGINE	1	
3	37099	PIN, ENGINE PIVOT	2	
4	37031	BUSHING, SPHERICAL-ULTRASERT UC200	2	
5	37147	PIN, UPPER ENGINE PIVOT	1	
6	37313	RING, SPIRAL RETAINING WHM-200	2	
7	37310	SCREW, HHC M14-2.0 X 40MM GRD 10.9 NP	6	
8	37146	SCREW, HHC M14-2.0 X 35MM GRD 10.9 NP	2	
9	913838	SCREW, HHC 3/4 - 10 X 4 GRD5 ZINC	1	
10	933245	WASHER, FLAT SAE 9/16 GRD 9 YZ	8	
11	4389	NUT, HEX 3/4 - 10	1	
12	16530	SCREW, HHC 7/16 - 14 X 1	2	
13	933243	WASHER, FLAT SAE 7/16 GRD 9 YZ	2	
14	37037	WASHER, ENGINE PIVOT PIN	4	
15	21376	SCREW, HHC 5/8 - 11 X 1-1/2	4	

AIR CLEANER ASSY.

AIR CLEANER ASSY.

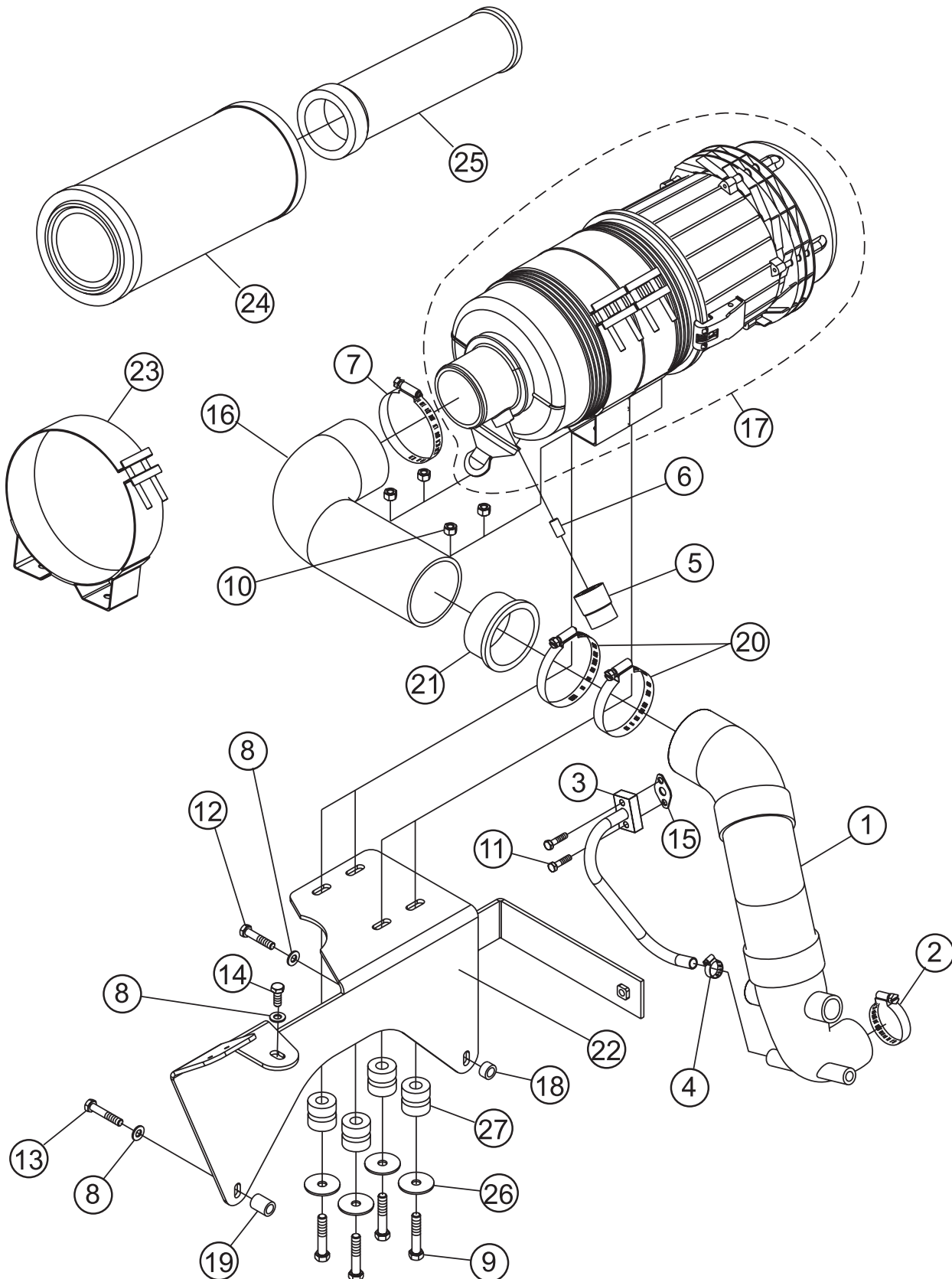

AIR CLEANER ASSY.

AIR CLEANER ASSY.

<u>NO.</u>	<u>PART NO.</u>	<u>PART NAME</u>	<u>QTY.</u>	<u>REMARKS</u>
1	37151	HOSE ASSY, AIR INTAKE	1	
2	10434	CLAMP, HOSE WORM # 32 1-9/16 TO 2"	1	
3	35309	TUBE, AIR INTAKE BREATHER	1	
4	15538	CLAMP, HOSE WORM # 6	1	
5	406018	INDICATOR, ELECTRICAL SERVICE	1	
6	65516	FITTING, NIPPLE 1/8" MP	1	
7	29218	CLAMP, HOSE WORM # 48	2	
8	933241	WASHER, FLAT SAE 5/16 GRD 9 YZ	3	
9	1665	SCREW, HHC 3/8 - 16 X 2	4	
10	10133	NUT, NYLOC 3/8 - 16	4	
11	M940653	SCREW, HHC M6 - 1.0 X 25MM GRD 10.9	2	
12	1928	SCREW, HHC M8 - 1.25 X 40MM	1	
13	9182	SCREW, HHC M8 - 1.25 X 45MM	1	
14	2866	SCREW, HHC M8 - 1.25 X 20MM	1	
15	35399	GASKET, AIR INTAKE TUBE	1	
16	37153	HOSE, 3.00 ID MOLDED 90 DEGREE	1	
17	37199	AIR CLEANER ASSEMBLY 3 INCH #7VLR	1	
18	37307	SPACER, AIR CLEANER MOUNT .375L	1	
19	37309	SPACER, AIR CLEANER MOUNT .875L	1	
20	962019	CLAMP, HOSE WORM # 44	2	
21	37317	BUSHING, AIR INTAKE 2.75 X 3.00	1	
22	37112	MOUNT, AIR FILTER	1	
23	37761	BRACKET, AIR INTAKE BODY	2	
24	P772579	PRIMARY FILTER, DEUTZ BF3L2013	1	
25	P775300	SAFETY FILTER, DEUTZ BF3L2014	1	
26	12832	WASHER, SNUBBING	4	
27	575001	RUBBER ISOLATOR, TPC #60166-1	4	

MUFFLER ASSY.

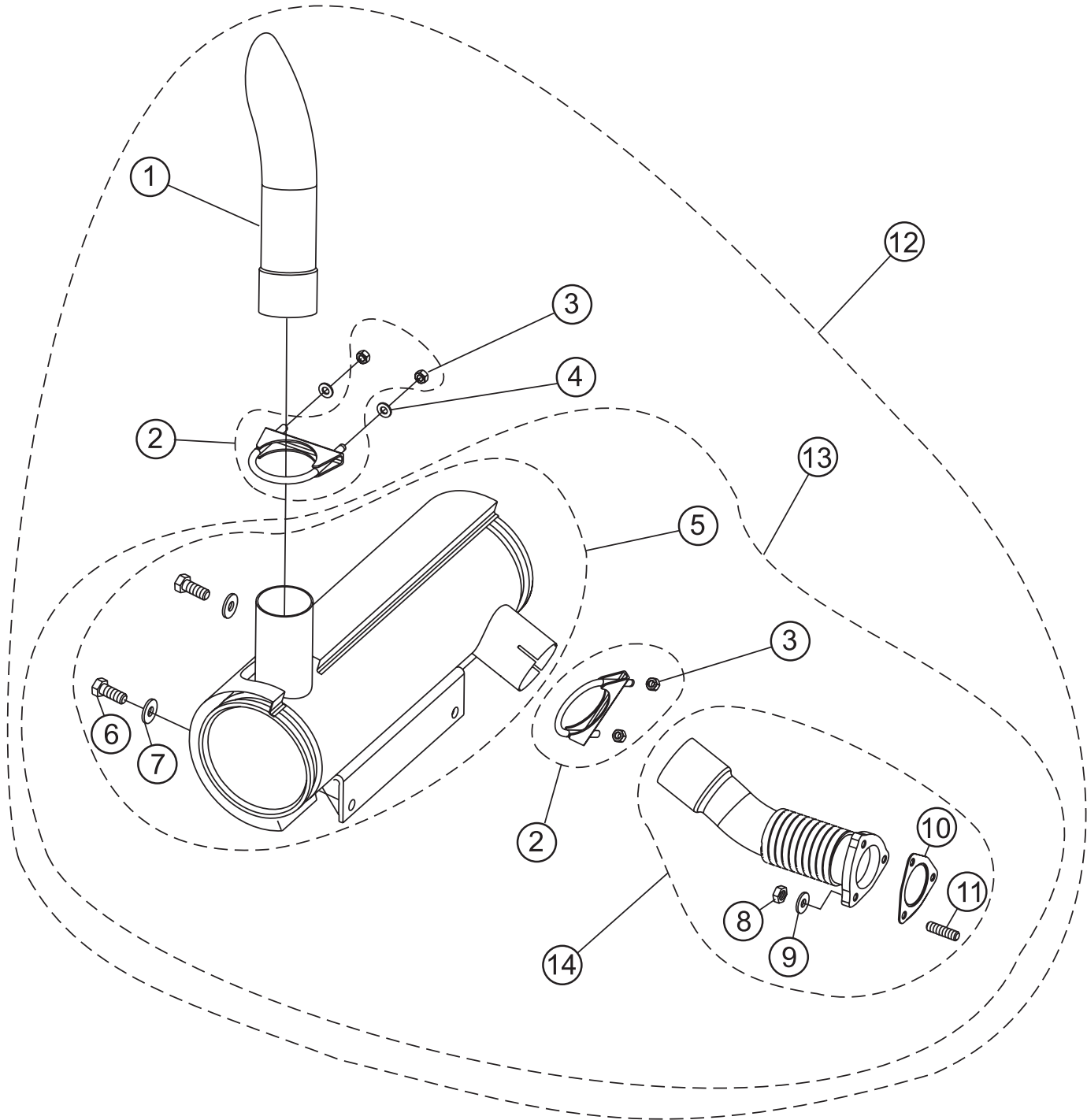

MUFFLER ASSY.

MUFFLER ASSY.

<u>NO.</u>	<u>PART NO.</u>	<u>PART NAME</u>	<u>QTY.</u>	<u>REMARKS</u>
1*	285003	EXHAUST, 12" EXTENSION	1	
2*#	570005	CLAMP, MUFFLER 2-1/2" 5/16 U-BOLT	2	
3*#	8131	NUT, FINISH L.H. 5/16 - 24	4	
4*#	933241	WASHER, FLAT SAE 5/16 GRD 9 YZ	4	
5*#	280005	MUFFLER	1	INCLUDES ITEMS W/%
6*#%	940693	SCREW, HHC M10 - 1.5 X 25MM GRD 10.9 NP	2	
7*#%	940358	WASHER, M10 X 21MM ZINC	2	
8*#\$	25592	NUT, M8 - 1.25"	3	
9*#\$	25591	WASHER, M8	3	
10*#\$	25642	GASKET, TURBO INLET DEUTZ	1	
11*#\$	25593	STUD, M8 - 1.25 X 30MM	3	
12	37143	MUFFLER ASSEMBLY COMPLETE	1	INCLUDES ITEMS W/*
13*	280002	MUFFLER AND FLEX KIT ASSEMBLY	1	INCLUDES ITEMS W/#
14*#	280004	FLEX KIT ASSEMBLY	1	INCLUDES ITEMS W/\$

LIFT BAIL ASSY.

LIFT BAIL ASSY.

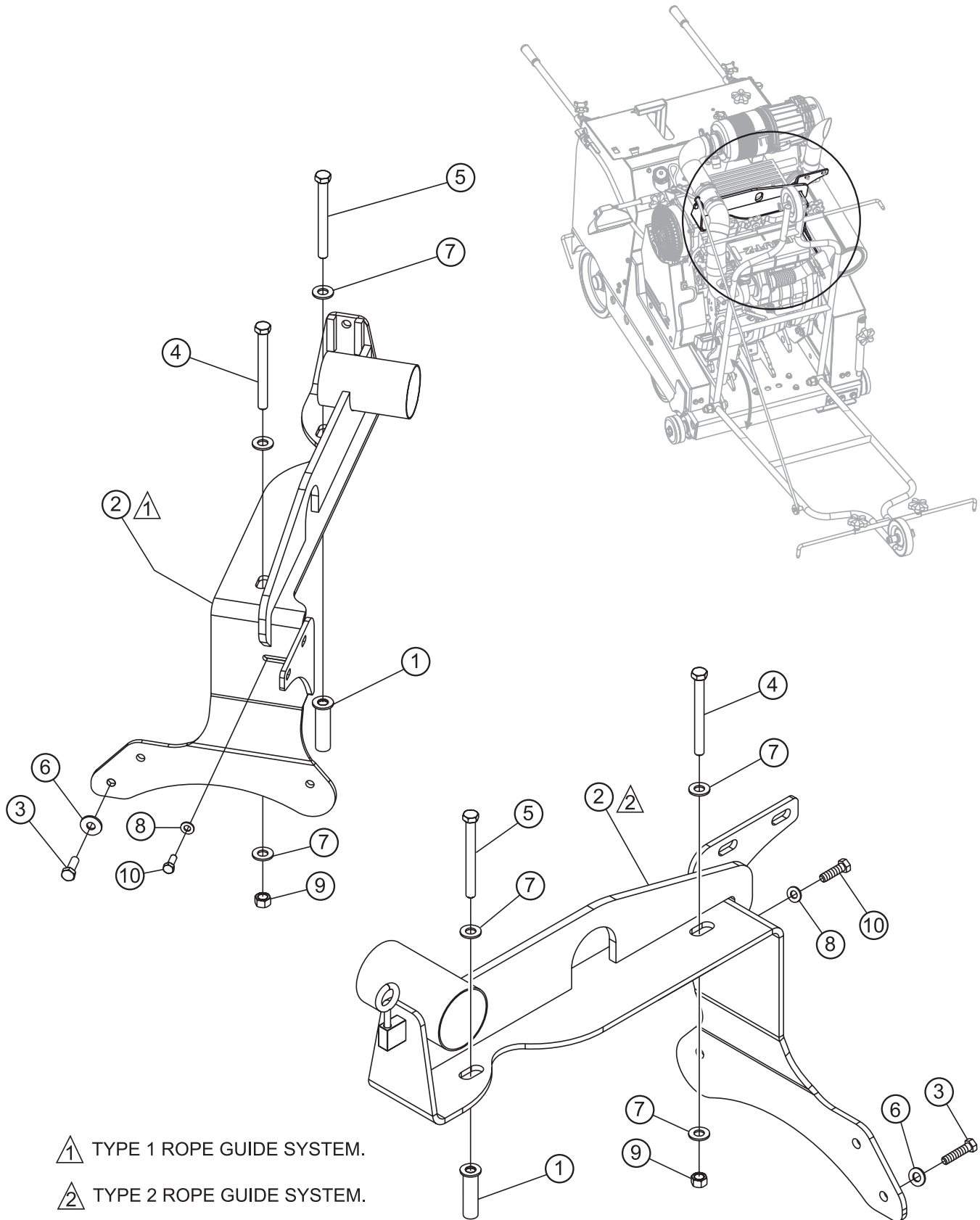

LIFT BAIL ASSY.

NO.	PART NO.	PART NAME	QTY.	REMARKS
1	37114	SPACER, DEUTZ ENGINE LIFTING BRACKET	1	
2	37115	BRACKET, DEUTZ ENGINE LIFTING	1	SEE NOTE BELOW
3	940694	SCREW, HHC M10 - 1.5 X 30MM FT 10.9 NP	1	
4	37314	SCREW, HHC M12 - 1.75 X 120MM TAP BOLT	1	
5	37315	SCREW, HHC M12 - 1.75 X 120MM 10.9 NP	1	
6	940358	WASHER, M10 X 21MM ZINC	1	
7	933244	WASHER, FLAT SAE 1/2 GRD 9 YZ	3	
8	933241	WASHER, FLAT SAE 5/16 GRD 9 YZ	1	
9	16083	NUT, HEX M12 - 1.75 NO PLATE	1	
10	06500-007	SCREW, HHC 5/16 - 18 X 7/8	1	



TYPE 2 ROPE GUIDE SYSTEM SUPERCEDES TYPE 1 ROPE GUIDE SYSTEM. SEE FRONT POINTER ASSY.

PLATFORM GUARDS/REAR POINTER ASSY.

PLATFORM GUARDS/REAR POINTER ASSY.

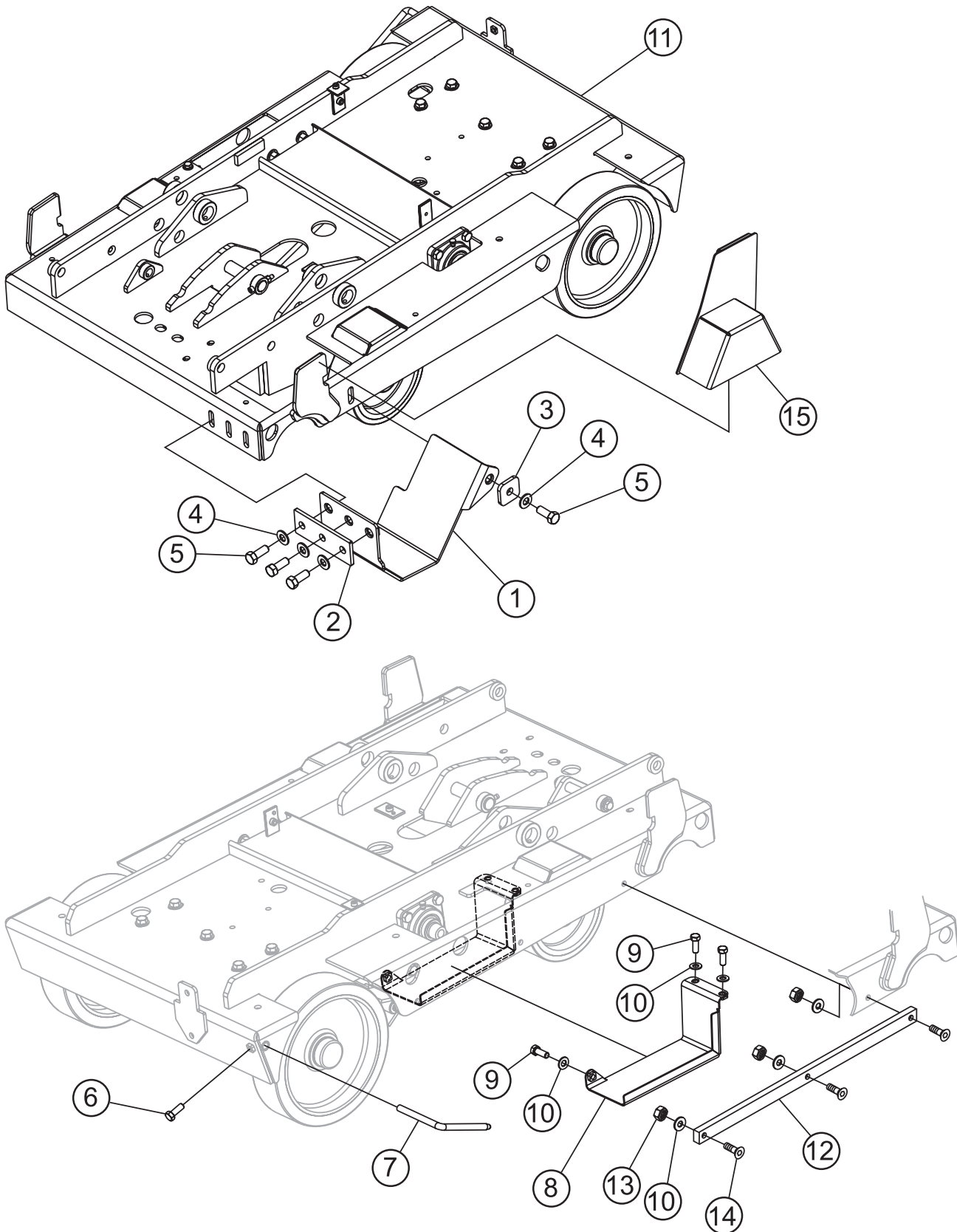

PLATFORM GUARDS/REAR POINTER ASSY.

PLATFORM GUARDS/REAR POINTER ASSY.

<u>NO.</u>	<u>PART NO.</u>	<u>PART NAME</u>	<u>QTY.</u>	<u>REMARKS</u>
1	37185	GUARD, BLADESHAFT PULLEY	1	SAFETY ITEM
2	583091	STRAP, LOWER BELT GUARD	1	
3	583092	WASHER, LOWER BELT PROTECTOR	1	
4	933244	WASHER, FLAT SAE 1/2 GRD 9 YZ	4	
5	3214	SCREW, HHC 1/2 - 13 X 1-1/4	4	
6	915105	SCREW, HHC 3/8 - 16 X 1.0 GRD 8	1	
7	110020	POINTER, REAR SAW	1	
8	37360	SHIELD, CONCRETE SLURRY	1	
9	915105	SCREW, HHC 3/8 - 16 X 1.0 GRD 8	3	
10	933242	WASHER, FLAT SAE 3/8 GRD 9 YZ	6	
11	37122	PLATFORM, W/A	1	
12	37450	STRIP, SLURRY CONTROL	1	
13	10133	NUT, NYLOC 3/8 - 16	3	
14	20982	SCREW, FHSC 3/8 - 16 X 1-1/2 PLATED	3	
15	M200000	GUARD, SAW BLADE COLLAR	1	

WHEEL DRIVE ASSY.

WHEEL DRIVE ASSY.

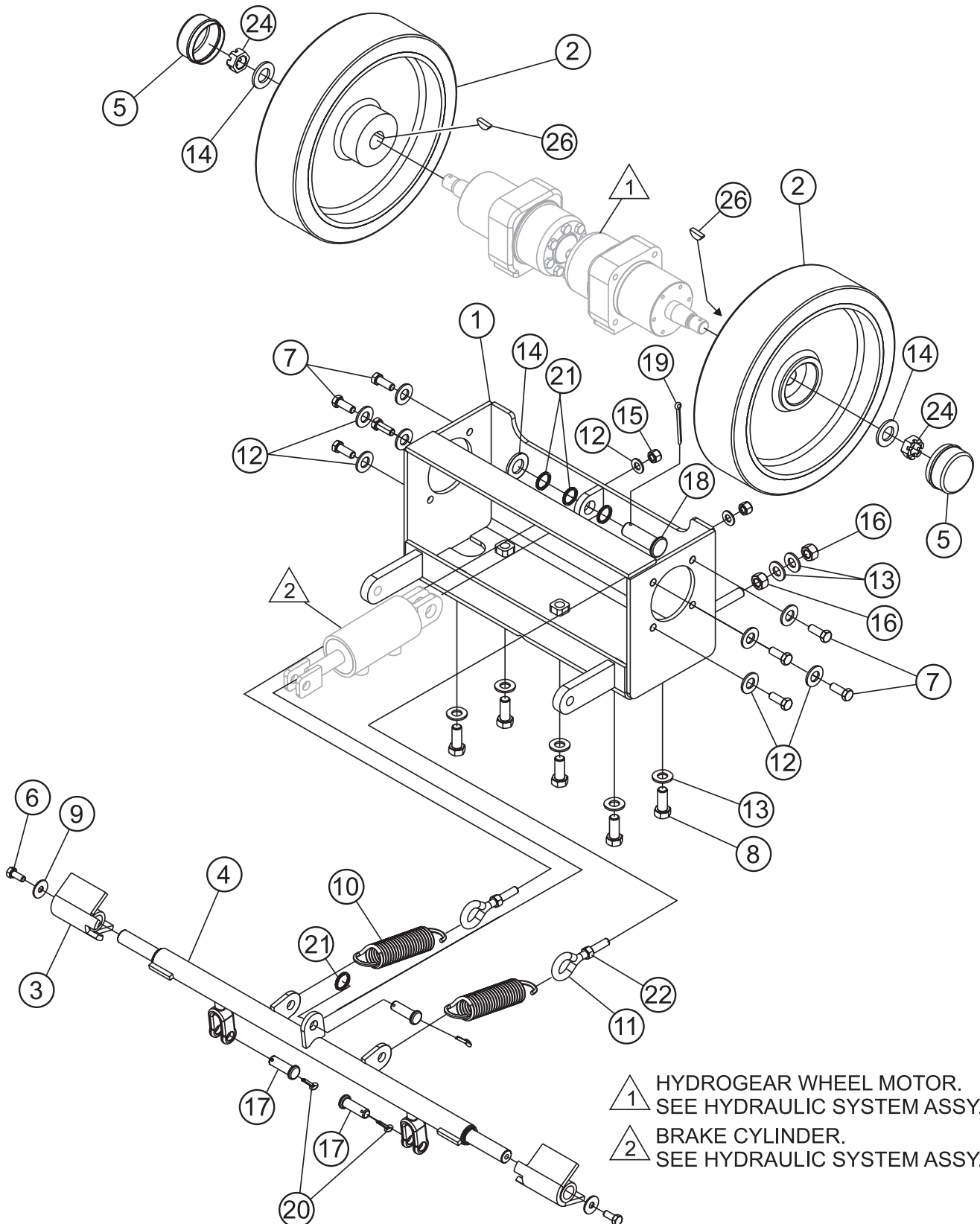

WHEEL DRIVE ASSY.

WHEEL DRIVE ASSY.

<u>NO.</u>	<u>PART NO.</u>	<u>PART NAME</u>	<u>QTY.</u>	<u>REMARKS</u>
1	37102	MOUNT, WHEEL MOTOR	1	
2	37095	WHEEL, 12 X 3 TAPERED BORE	2	
3	37096	BRAKE PAD	2	
4	37097	BRAKE ARM	1	
5	37138	CAP, WHEEL DUST	2	
6	0655	SCREW, HHC 5/16 - 18 X 3/4	2	
7	0205	SCREW, HHC 3/8 - 16 X 1.0	8	
8	3214	SCREW, HHC 1/2 - 13 X 1-1/4	5	
9	933213	WASHER, FENDER 5/16 X 1 ZINC	2	
10	37048	SPRING, 1.125 X .187 X 4 W/EYELET	2	
11	23858-001	EYEBOLT, 3/8 - 16 X 2.0	2	
12	933242	WASHER, FLAT SAE 3/8 GRD 9 YZ	10	
13	933244	WASHER, FLAT SAE 1/2 GRD 9 YZ	7	
14	933247	WASHER, FLAT SAE 3/4 GRD 9 YZ	3	
15	10133	NUT, NYLOC 3/8 - 16	2	
16	968011	NUT, HEX FINISH 1/2 - 13	2	
17	19974	PIN, CLEVIS 1/2 X 1.25	3	
18	966166	PIN, CLEVIS 3/4 X 2	1	
19	965105	PIN, COTTER 5/32 X 1-1/2	1	
20	965103	PIN, COTTER 5/32 X 1	3	
21	37322	SPRING, CREST TO CREST	4	
22	1456	NUT, HEX FINISH 3/8 - 16	2	
24	12426	NUT, SLOTTED 3/4-16	2	
26	0126	KEY, WOODRUFF #606 3/16 X 3/4	2	

FRONT AXLE ASSY.

FRONT AXLE ASSY.

<u>NO.</u>	<u>PART NO.</u>	<u>PART NAME</u>	<u>QTY.</u>	<u>REMARKS</u>
1	37106	FRONT AXLE W/A	1	
2	933246	WASHER, FLAT 5/8 SAE GRD9 YZ	2	
3	06505-008	SCREW, HHC 5/8 - 11 X 1.00	2	
4	37132	WHEEL ASSEMBLY, FRONT	2	INCLUDES ITEMS W/*
5	2621	FITTING, GREASE ZERK STR 1/4 - 28	2	
6	26091	SCREW, SHS 1/4 - 28 X 1/4 CUP POINT	4	
7	2186	SCREW, SHC 5/16 - 18 X 2-1/4 PLTD	1	
8	926064	SCREW, SQHS CUP POINT 5/16 - 24 X 5/8	1	
9	5283	NUT, NYLOC 5/16 - 18	1	
10	1162 A	CAP, GREASE ZERK #2 YELLOW	2	
11	37040	BEARING, 1.250" FLANGE	2	
12	933244	WASHER, FLAT SAE 1/2 - 13 GD 8	16	
13	16629	NUT, NYLOC 12 - 13 GD 8	12	
14	37260	PIN, LIFT CYLINDER	1	
15	915211	SCREW, HHC 1/2 - 13 X 2 GRD8 YZ	12	
16	37138	CAP, WHEEL DUST	2	
17*	37131	WHEEL, 8 X 3 POLYURETHANE	2	
18*	460002	BEARING, BALL KOYO # 6005 SRS	4	
19*	485002	SEAL, OIL CR # 28655	2	
20*	576003	SNAP RING, - HO-185	2	
21	37165	PLATE, BACKING	2	

HYDRAULIC SYSTEM ASSY.

HYDRAULIC SYSTEM ASSY.

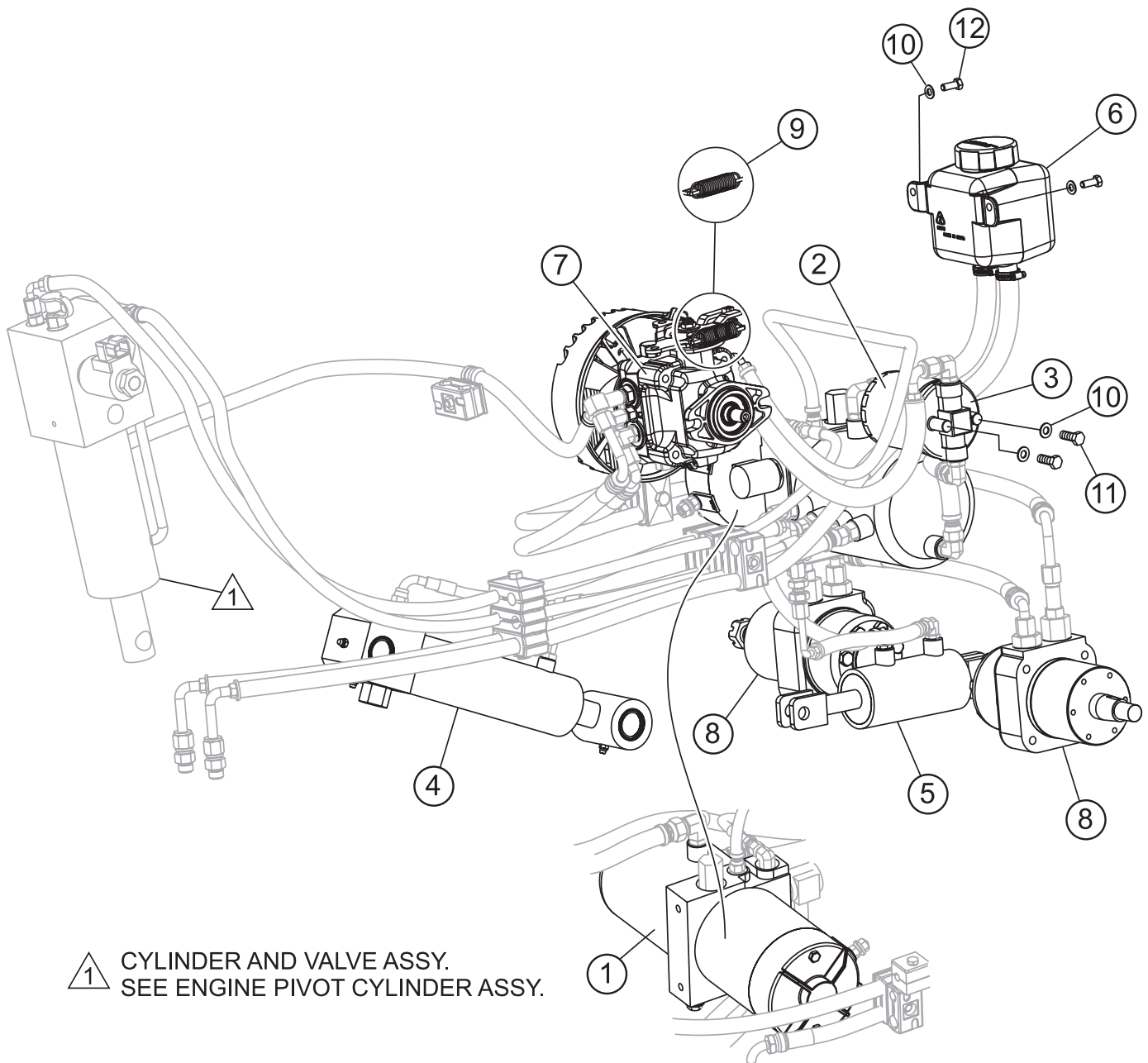

HYDRAULIC SYSTEM ASSY.

HYDRAULIC SYSTEM ASSY.

<u>NO.</u>	<u>PART NO.</u>	<u>PART NAME</u>	<u>QTY.</u>	<u>REMARKS</u>
1	37113	PUMP, 24V DC LIFT - HYDROGEAR	1	
2	306006	FILTER, TRANSAXLE	1	
3	25617	FILTER HEAD, TRANSAXLE	1	
4	37121	LIFT CYLINDER ASSEMBLY	1	
5	37211	CYLINDER, BRAKE 2" X 1.5" STROKE	1	
6	37213	RESERVOIR, 350ML HYDROGEAR 71327	1	
7	37104	PUMP, HYDROGEAR	1	
8	37056	MOTOR, WHEEL - HYDROGEAR HGM-15P-7131	2	
9	37162	EXTENSION SPRING, 1.8" - 8.1 LB RATE	1	
10	933240	WASHER, FLAT SAE 1/4 GRD 9 YZ	4	
11	1579	SCREW, HHC 1/4 - 20 X .5	2	
12	4514	SCREW, HHC 1/4 - 20 X 5/8 GRD 5	2	

ENGINE PIVOT CYLINDER ASSY.

ENGINE PIVOT CYLINDER ASSY.

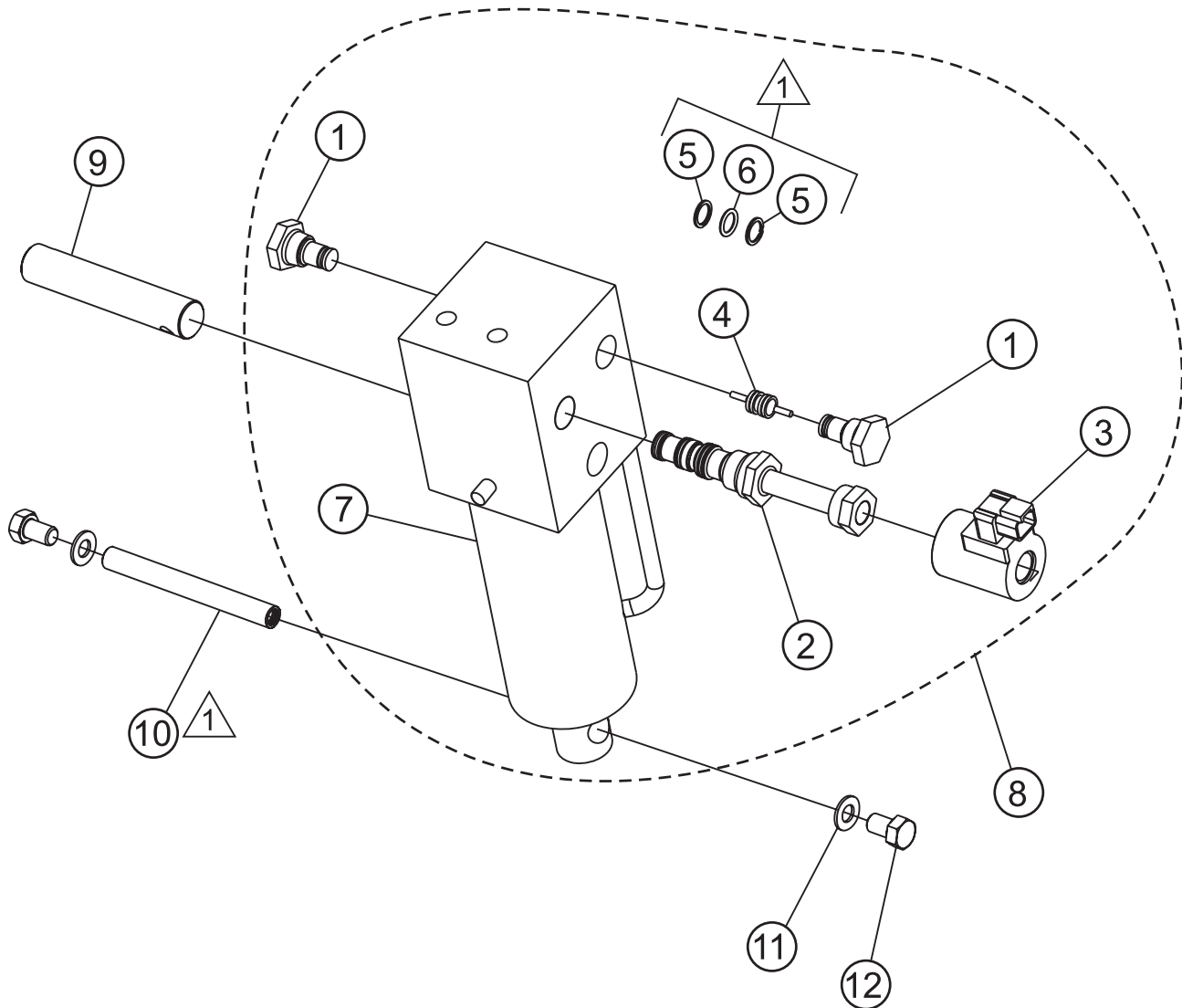

 ITEMS 5 AND 6 USED ON SAWS
S/N ZD3700241 AND BELOW

ENGINE PIVOT CYLINDER ASSY.

ENGINE PIVOT CYLINDER ASSY.

<u>NO.</u>	<u>PART NO.</u>	<u>PART NAME</u>	<u>QTY.</u>	<u>REMARKS</u>
1*	37445	VALVE, CHECK	2	
2*	37446	VALVE, CARTRIDGE 4-WAY 2-POSITION	1	
3*	37447	SOLENOID COIL 12VDC	1	
4*	37448	PISTON, PILOT	1	
5*	37449	PISTON, BACKUP RING	2	S/N ZD3700241 AND BELOW
6*	37492	O-RING	1	S/N ZD3700241 AND BELOW
7*	37390	CYLINDER, HYDRAULIC	1	
8	37495	CYLINDER AND VALVE ASSEMBLY	1	INCLUDES ITEMS W/*
9	37260	PIN, LIFT CYLINDER	1	
10	37166	PIN, LOWER ENGINE PIVOT	1	
11	933243	WASHER, FLAT SAE 7/16 GRD 9 YZ	2	
12	16530	SCREW, HHC 7/16 - 14 X 1	2	

HYDRAULIC HOSES ASSY.

HYDRAULIC HOSES ASSY.

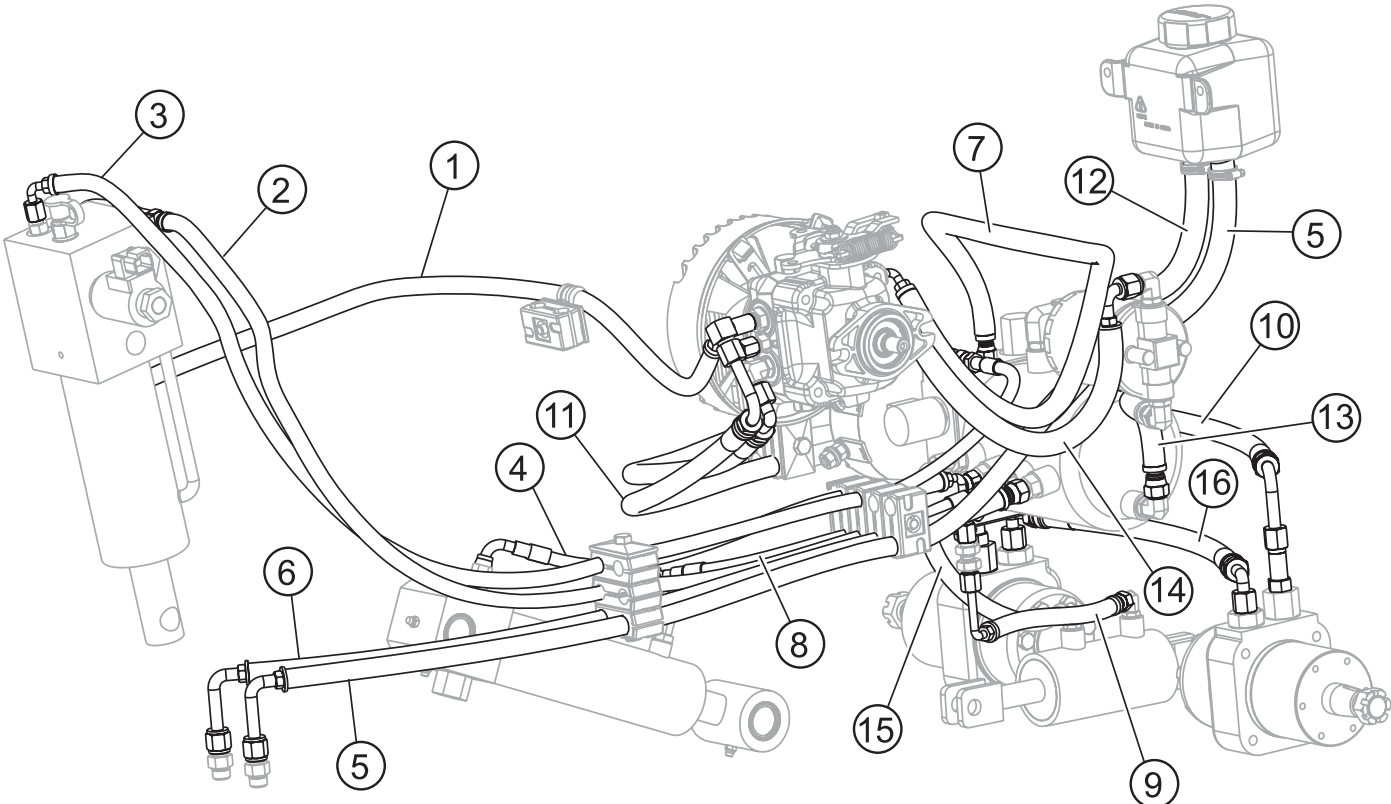

HYDRAULIC HOSES ASSY.

HYDRAULIC HOSES ASSY.

<u>NO.</u>	<u>PART NO.</u>	<u>PART NAME</u>	<u>QTY.</u>	<u>REMARKS</u>
1	37475	HOSE ASSEMBLY, #4 LP	1	
2	37476	HOSE ASSEMBLY, #4 LP	1	
3	37477	HOSE ASSEMBLY, #4 LP	1	
4	37290	HOSE ASSEMBLY, #4 HP PARFLEX	1	
5	37295	HOSE ASSEMBLY, #6-8 LP	1	
6	37294	HOSE ASSEMBLY, #6 LP	1	
7	37347	HOSE ASSEMBLY, #6 LP	1	SEE NOTE BELOW
8	37291	HOSE ASSEMBLY, #4 PARFLEX	1	
9	37292	HOSE ASSEMBLY, #4 LP	1	
10	37278	HOSE ASSEMBLY, #6 PARFLEX	1	
11	37279	HOSE ASSEMBLY, #6 PARFLEX	1	
12	37283	HOSE ASSEMBLY, #8 LP	1	
13	37281	HOSE ASSEMBLY, #6 LP	1	
14	37282	HOSE ASSEMBLY, #6 LP	1	
15	37293	HOSE ASSEMBLY, #4 LP	1	
16	37280	HOSE ASSEMBLY, DRIVE MOTOR CROSSOVER	1	



FOR SAWS UP TO S/N ZD3700238 ONLY.
 WHEN ORDERING THIS HOSE (P/N 37347 ITEM 7 ON THIS PAGE), ALSO ORDER TWO (2) EACH FITTINGS (P/N 11887, ITEM 22 SHOWN ON HYDRAULIC FITTINGS AND CLAMPS ASSY).

HYDRAULIC FITTINGS AND CLAMPS ASSY.

HYDRAULIC FITTING AND CLAMPS ASSY.

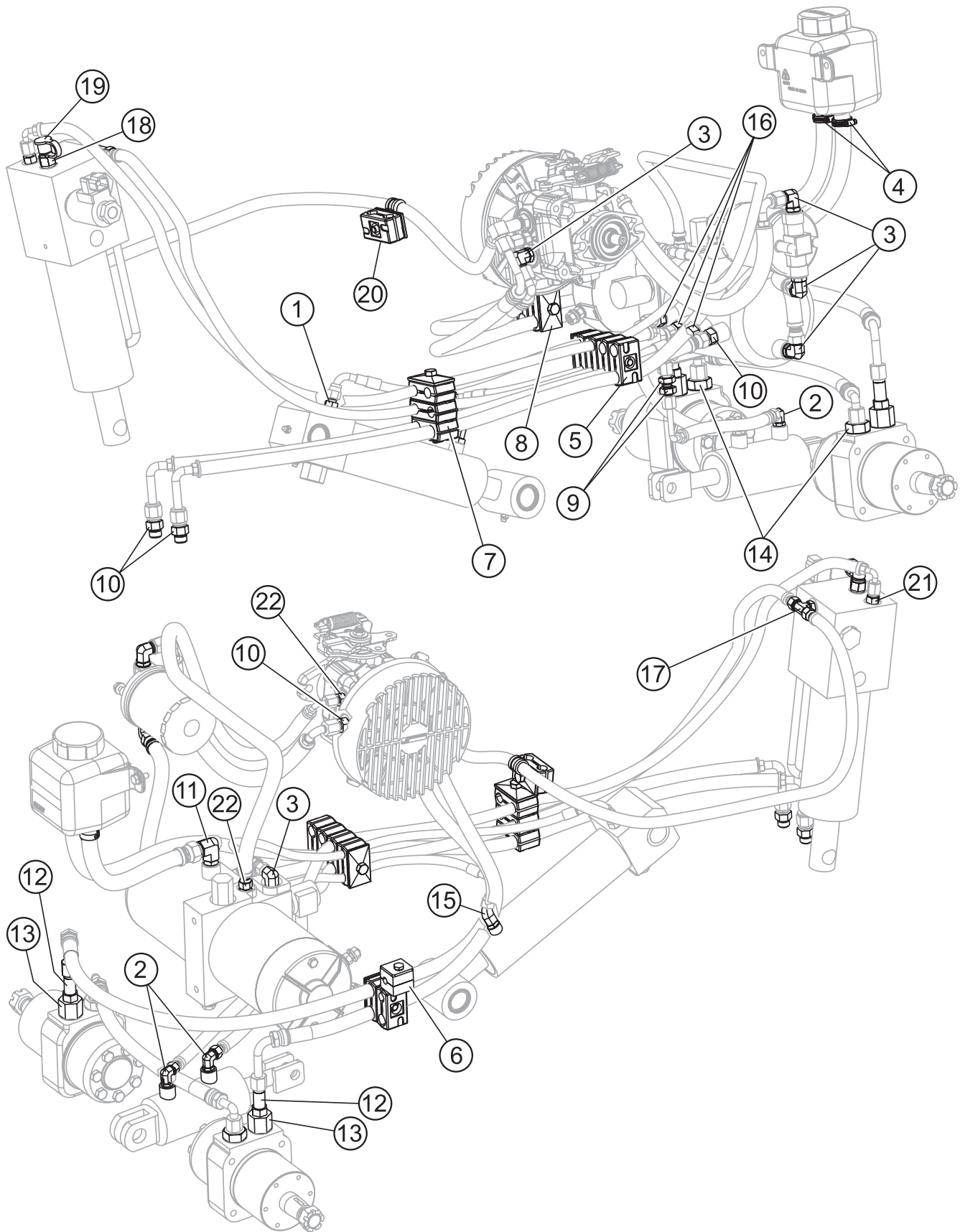

HYDRAULIC FITTINGS AND CLAMPS ASSY.

HYDRAULIC FITTING AND CLAMPS ASSY.

<u>NO.</u>	<u>PART NO.</u>	<u>PART NAME</u>	<u>QTY.</u>	<u>REMARKS</u>
1	21095	FITTING, STR 4MJ - 4MO	1	
2	368817	FITTING, 90 4MJ - 4MO	2	
3	11722	FITTING, 90 6MJ - 6MO	4	
4	15538	CLAMP, HOSE WORM #6, 7/16" TO 7/8"	2	
5	37793	CLAMP ASSEMBLY, HOSE	1	
6	37352	CLAMP ASSEMBLY, 5/16 HOSE	1	
7	37792	CLAMP ASSEMBLY, HOSE	1	
8	37433	CLAMP ASSEMBLY, HOSE	1	
9	366437	FITTING, BULKHEAD #4 JIC	1	
10	11721	FITTING, STR 6MJ - 6MO	4	
11	12431	FITTING, 90 8MJ - 6MO	1	
12	21115	FITTING, STR 6MJ - 6MO LONG	2	
13	37405	FITTING, 10MO X - 6FO - ST	2	
14	37406	FITTING, 6MJ X 10MO - ST	2	
15	21159	FITTING, 45 4MJ - 4MO	1	
16	367470	FITTING, STR 4MJ - 6MO	3	
17	37788	FITTING, TEE 4MO - 4MO - 4MJ	1	
18	12147	FITTING, QD 6MO DIAGN PARKER PD 361	1	
19	12148	CAP, DUST DIAG PARKER PD6 - 285	1	
20	35022	CLAMP, LOOP CUSHIONED #8	1	
21	37493	FITTING, ORIFICE 4MJ - 4MO X .100	1	
22	11887	FITTING, STR 6MJ - 4MO	2	SEE NOTE BELOW



FOR SAWS UP TO S/N ZD3700238 ONLY.

WHEN ORDERING HOSE (P/N 37347 ITEM 7 ON HYDRAULIC HOSES ASSY), ALSO ORDER TWO (2) EACH FITTINGS P/N 11887, ITEM 22 SHOWN ON THIS PAGE.

FRONT POINTER ASSY.

FRONT POINTER ASSY.

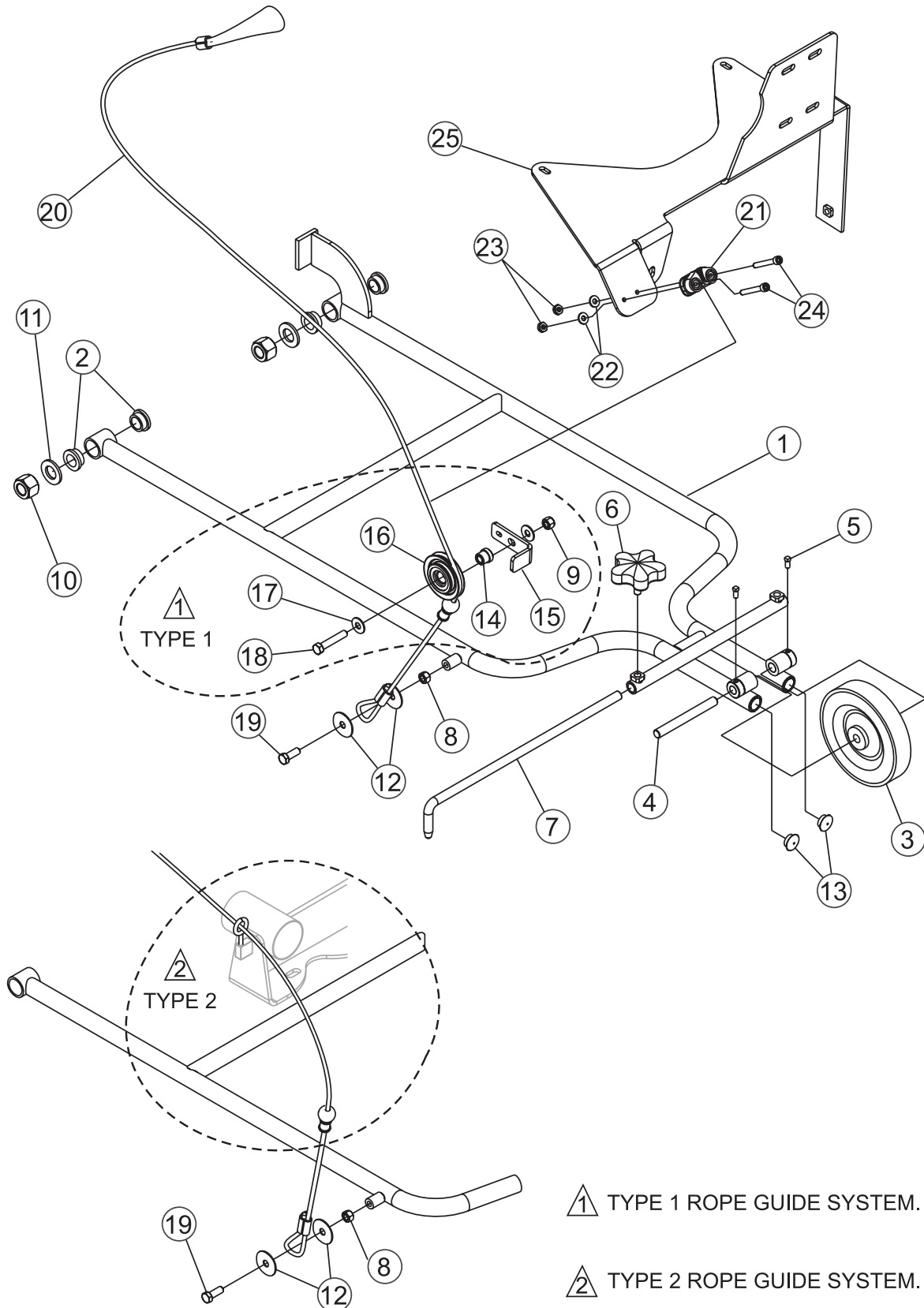

1 TYPE 1 ROPE GUIDE SYSTEM.

2 TYPE 2 ROPE GUIDE SYSTEM.

FRONT POINTER ASSY.

FRONT POINTER ASSY.

<u>NO.</u>	<u>PART NO.</u>	<u>PART NAME</u>	<u>QTY.</u>	<u>REMARKS</u>
1	37182	POINTER	1	
2	582008	BUSHING, FLANGE 1.0 OD X .75 ID	4	
3	500005	WHEEL, POINTER 6" X 1"	1	
4	37178	AXLE, POINTER WHEEL	1	
5	926006	SCREW, SQHS CP 1/4 - 20 X1/2	2	
6	15503	KNOB, COMFORT GRIP STAR	1	
7	110038	SAW POINTER 15" RH FRONT	1	
8	1456	NUT, HEX FINISH 3/8 - 16	1	
9	10133	NUT, NYLOC 3/8 - 16	1	SEE NOTE BELOW
10	5070 B	NUT, NYLOC 3/4 - 10	2	
11	933247	WASHER, FLAT SAE 3/4 GRD 9 YZ	2	
12	3233	WASHER, FENDER 1.50 OD X 3/8 ID	2	
13	37261	PLUG, FINISHING 3/4"	2	
14	544002	SHOULDER, ADAPTER	1	SEE NOTE BELOW
15	125043-3	RETAINER, SAW POINTER CABLE	1	SEE NOTE BELOW
16	540039	PULLEY, POINTER ROPE	1	SEE NOTE BELOW
17	10136	WASHER, FLAT SAE 3/8	2	SEE NOTE BELOW
18	1665	SCREW, HHC 3/8 - 16 X 2	1	SEE NOTE BELOW
19	0205	SCREW, HHC 3/8 - 16 X 1.0	1	
20	574003	ROPE, POINTER ASSY.	1	INCLUDES BALL & CRIMP
21	574002	CAM CLEAT	1	
22	15173	WASHER, FLAT #8	2	
23	13287	NUT, NYLOC 8 - 32	2	
24	923199	SCREW, SHC 8 - 32 X 1-1/4	2	
25	37112	MOUNT, AIR FILTER	1	

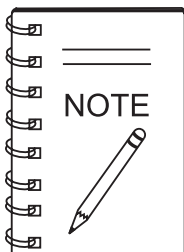

THESE PARTS ARE USED ONLY ON "TYPE 1" ROPE GUIDE SYSTEMS SHOWN IN ILLUSTRATION ON LIFT BAIL ASSY. TYPE 2 ROPE GUIDE SYSTEM SUPERCEDES TYPE 1 ROPE GUIDE SYSTEM. SEE ILLUSTRATION.

BELT DRIVE ASSY.

BELT DRIVE ASSY.

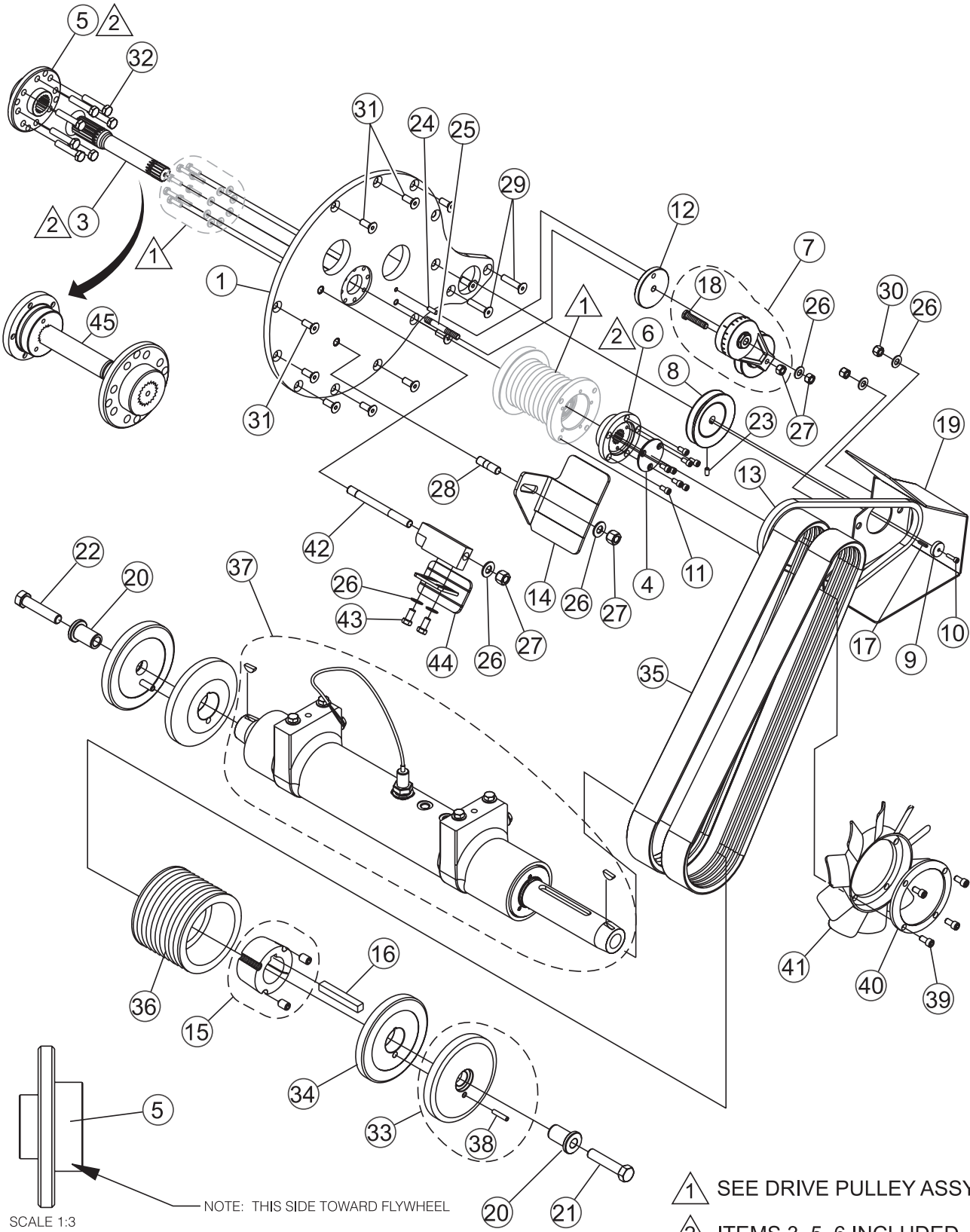

▲ 1 SEE DRIVE PULLEY ASSY.

▲ 2 ITEMS 3, 5, 6 INCLUDED WITH ITEM 45, SPLINED DRIVE ASSY, P/N 37833

BELT DRIVE ASSY.

BELT DRIVE ASSY.

<u>NO.</u>	<u>PART NO.</u>	<u>PART NAME</u>	<u>QTY.</u>	<u>REMARKS</u>
1	37001	PLATE, ENGINE ADAPTER-DEUTZ	1	
3#		SHAFT, ENGINE DRIVE-DEUTZ	1	
4	37019	PLATE, PULLEY DRIVE COVER	1	
5#		FLANGE, ENGINE DRIVE-DEUTZ	1	
6#		FLANGE, PULLEY DRIVE-DEUTZ	1	
7	37137	BELT TENSIONER ASSY.	1	INCLUDES ITEMS W/*
8	37002	PULLEY, PUMP DRIVE 3.75" A-SECTION	1	
9	37319	WASHER, THRUST 1.00 OD X .265 L X .265 H	1	
10	37320	SCREW, SHC 10-32 X 3/4	1	
11	923201	SCREW, SHC 1/4 - 20 X 1/2	8	
12	37267	SPACER, BELT TENSIONER	1	
13	21004-003	BELT, AX-35	1	
14	37755	SHOE, LOWER BELTSIDE	1	
15	460016	BUSHING, TAPER-LOCK 2517 X 1-7/8	1	FITS 20", 26", 30", 36"
15	460023	BUSHING, TAPER-LOCK 2012 X 1-7/8	1	FITS 16"
16	10057-061	KEY, 1/2" SQ X 3-1/2"	1	
17	37269	KEY, SQUARE 1/8 X 3/4	1	
18*	37266	SCREW, MODIFIED HEAD 3/8 X 1-3/4	1	
19	37218	GUARD, PUMP DRIVE	1	SAFETY ITEM
20	582012	BUSHING, QUICK DISCONNECT BLADE SHAFT	2	
21	915315	SCREW, HHC 5/8 - 11 X 3 GR8	1	
22	915316	SCREW, HHC 5/8 - 11 X 3 LH GR8	1	
23	10138	SCREW, SHS 1/4 - 20 X 1/2 NP	1	
24	926919	PIN, DOWEL 1/4 X 3/4	1	
25	37268	STUD, 3/8 - 16 X 3 SELF-LOCKING	1	
26	933242	WASHER, FLAT SAE 3/8 GRD 9 YZ	5	
27	1456	NUT, HEX FINISH 3/8 - 16	4	
28	37762	STUD, 1/2 - 13 X 1-3/4	1	
29	924289	SCREW, FHSC 3/8 - 16 X 1-3/4	2	
30	10133	NUT, NYLOC 3/8 - 16	2	
31	939978	SCREW, FHSC M10 - 1.5 X 25MM NP	11	
32	938422	SCREW, HHC M10 - 1.0 X 50MM 10.9 NP	8	
33	37177	FLANGE ASSY, 6.0" OUTER BLADE	2	FITS 30", 36" BELT DRIVE
33	37169	FLANGE ASSY, 5.0" OUTER BLADE	2	FITS 16", 20", 26" BELT DRIVE
34	37176	FLANGE ASSY, 6.0" INNER BLADE	2	FITS 30", 36" BELT DRIVE
34	37168	FLANGE ASSY, 5.0" INNER BLADE	2	FITS 16", 20", 26" BELT DRIVE
35	520007	V-BELT, 5G 3 VX 530 POWERBAND	2	
36	540047	PULLEY, 5.6 10G 3V X 2517 TAPER	1	FITS 36" BELT DRIVE
36	540041	PULLEY, 5.3 10G 3V X 2517 TAPER	1	FITS 30" BELT DRIVE
36	540040	PULLEY, 5.0 10G 3V X 2517 TAPER	1	FITS 26" BELT DRIVE
36	540035	PULLEY, 4.75 10G 3V X 2517 TAPER	1	FITS 20" BELT DRIVE
36	540046	PULLEY, 4.2 10G 3V X 2012 TAPER	1	FITS 16" BELT DRIVE

CONTINUED NEXT PAGE

BELT DRIVE ASSY.

BELT DRIVE ASSY. (CONTINUED)

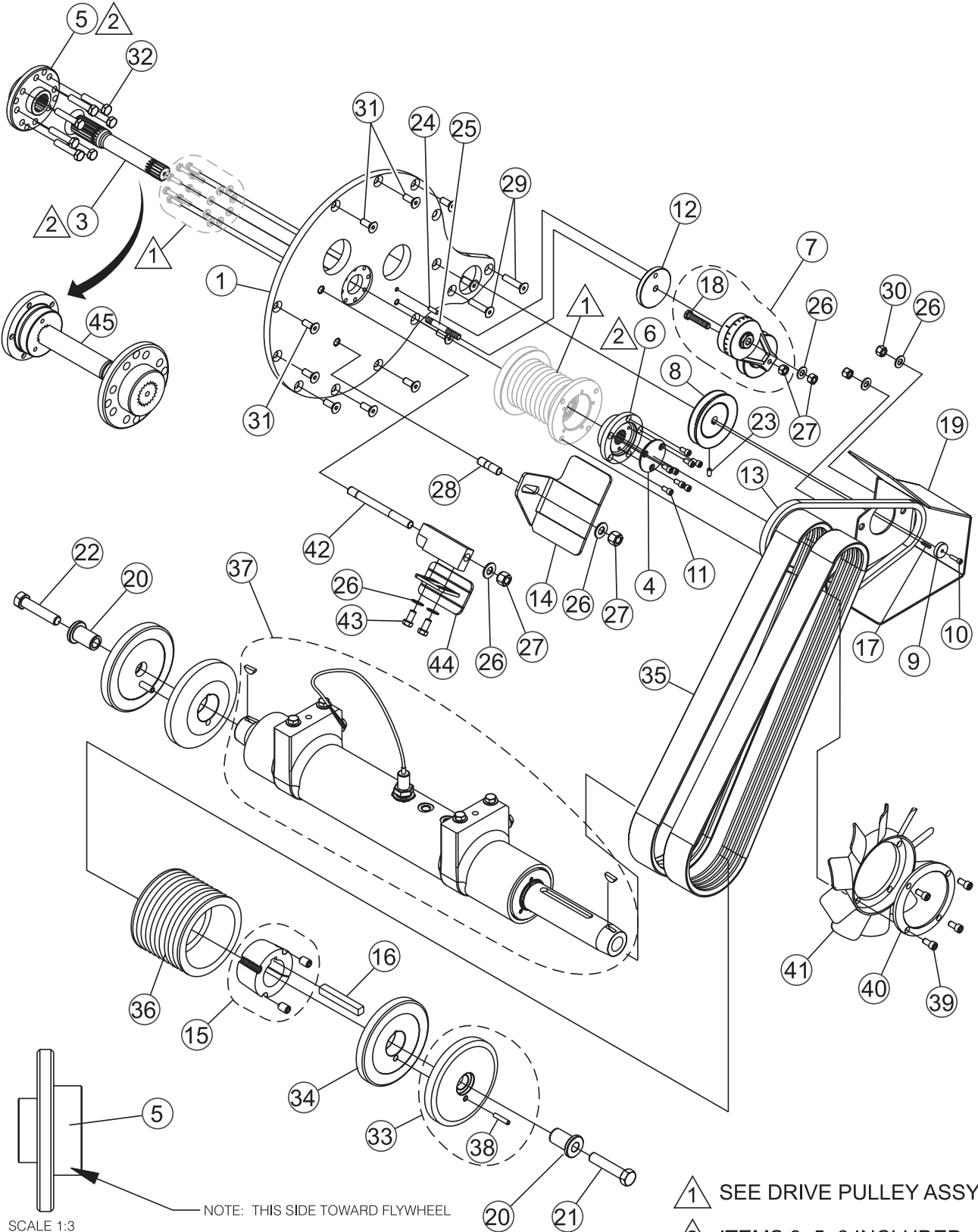

SCALE 1:3

NOTE: THIS SIDE TOWARD FLYWHEEL

- ▲ 1 SEE DRIVE PULLEY ASSY.
- ▲ 2 ITEMS 3, 5, 6 INCLUDED WITH ITEM 45, SPLINED DRIVE ASSY, P/N 37833

BELT DRIVE ASSY.

BELT DRIVE ASSY. (CONTINUED)

<u>NO.</u>	<u>PART NO.</u>	<u>PART NAME</u>	<u>QTY.</u>	<u>REMARKS</u>
37	37134	BLADE SHAFT ASSY.	1	
38	926790	PIN, DOWEL 3/8 X 1-3/4	2	INCLUDED W/ ITEM 33
39	25992	SCREW, SHC 12 - 24 X 1/2	4	
40	37735	RING, FAN MOUNT	1	
41	37734	FAN, CW 8" 10 BLADE	1	
42	37763	STUD, 1/2 - 13 X 5-1/2	1	
43	915103	SCREW, HHC 3/8 - 16 X 3/4 GR8 YZ	2	
44	37756	SHOE, UPPER BELTSIDE	1	
45	37833	SPLINED DRIVE ASSY.	1	INCLUDES ITEMS W/#

DRIVE PULLEY ASSY.

DRIVE PULLEY ASSY.

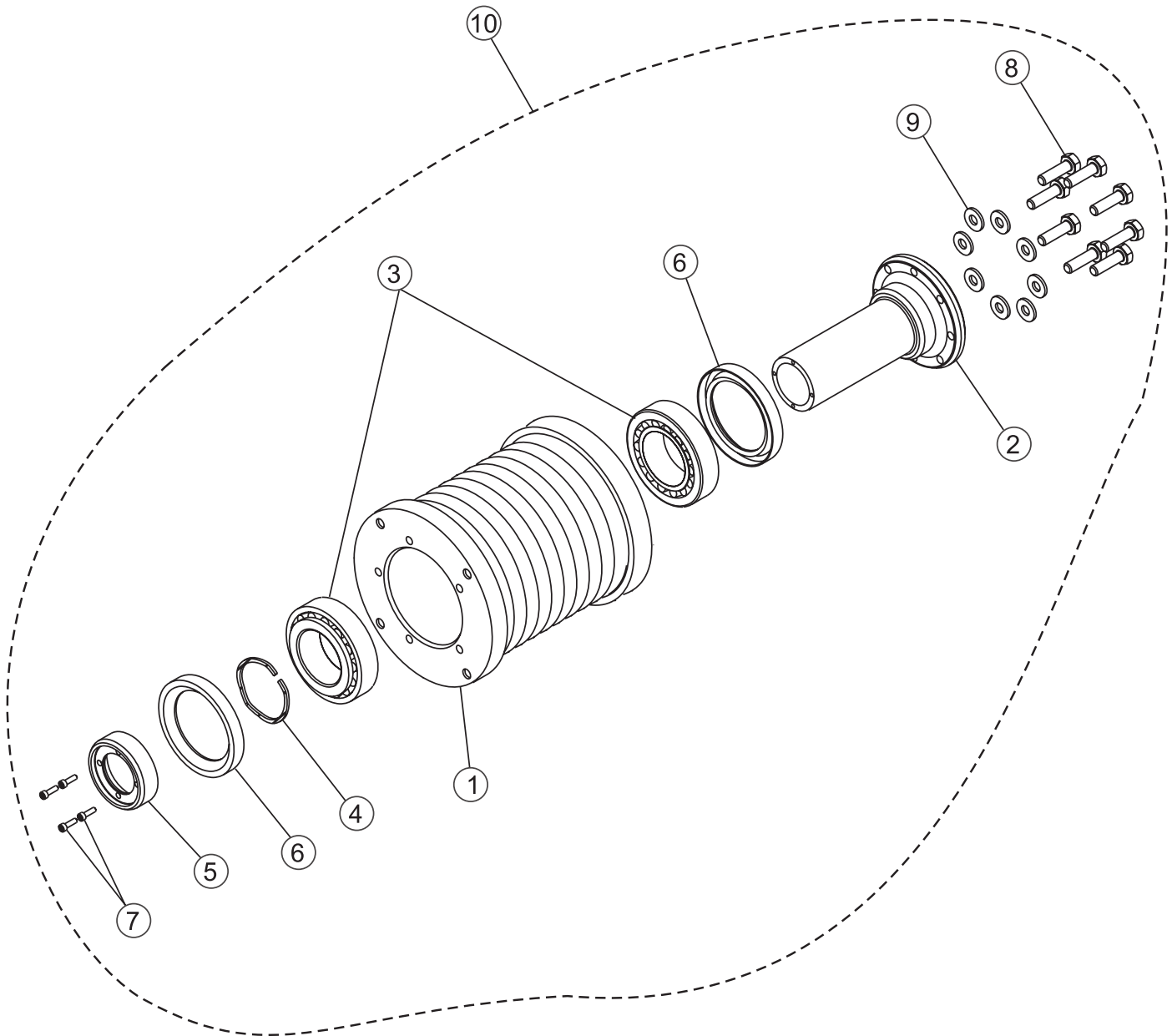

DRIVE PULLEY ASSY.

DRIVE PULLEY ASSY.

<u>NO.</u>	<u>PART NO.</u>	<u>PART NAME</u>	<u>QTY.</u>	<u>REMARKS</u>
1*	37011	PULLEY, 3.3 10 3V 4.5 1A	1	FITS 26", 30", 36" BELT DRIVE
1#	37154	PULLEY, 4.1 3V 4.5 1A	1	FITS 16", 20" BELT DRIVE
2*#	37003	SUPPORT, ENGINE DRIVE BEARING	1	
3*#	37028	BEARING, TAPERED ROLLER NSK #32007XJ	2	
4*#	37090	SPRING, SMALLEY WAVO RW-0162	1	
5*#	37017	FLANGE, ENGINE DRIVE BEARING SUPPORT	1	
6*#	37092	SEAL, CR 17753	2	
7*#	37035	SCREW, SHC 4-40 X 3/8	4	
8*#	915004	SCREW, HHC 1/4 - 20 X 7/8 GR8 YZ	8	
9*#	933240	WASHER, FLAT SAE 1/4 GRD 9 YZ	8	
10	37103	DRIVE PULLEY ASSY., 3.3 10 3V 4.5 1A	1	FITS 26", 30", 36" BELT DRIVE INCLUDES ITEMS W/*
10	37321	DRIVE PULLEY ASSY., 4.1 3V 4.5 1A	1	FITS 16", 20" BELT DRIVE INCLUDES ITEMS W/#

BLADE SHAFT ASSY.

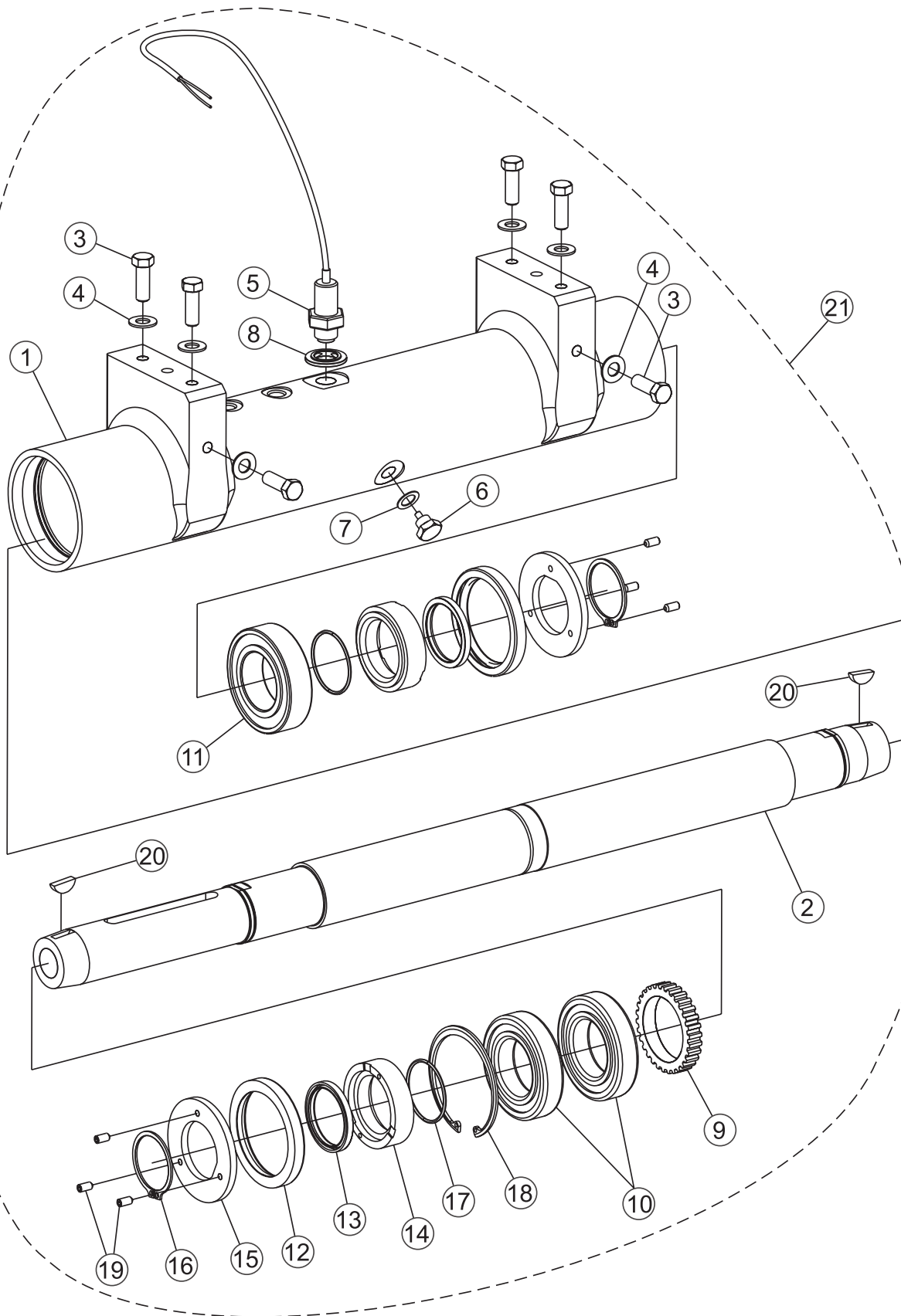

BLADESHAFT ASSY.

BLADE SHAFT ASSY.

<u>NO.</u>	<u>PART NO.</u>	<u>PART NAME</u>	<u>QTY.</u>	<u>REMARKS</u>
1*	37108	HOUSING, BLADESHAFT	1	
2*	37111	BLADESHAFT, 7000 SERIES	1	
3*	06502-010	SCREW, HHC 7/16 - 14 X 1-1/4	6	
4*	933243	WASHER FLAT SAE 7/16 GRD 9 YZ	6	
5*	421001	SENSOR, HALL EFFECT SPEED PICKUP	1	
6*	583026	DRAIN PLUG, MAGNETIC 1/2 - 20	1	
7*	577009	GASKET, DRAIN PLUG	1	
8*	25695	WASHER, SEAL 3/4"	1	
9*	25690	GEAR, SAW BLADE SHAFT SPEED PICKUP	1	
10*	460010	BEARING, ROLLER KOYO # 7210BGC3	2	
11*	39460011	BEARING, BALL KOYO # NU2210RC3	1	
12*	480006	SEAL, OIL CR# 28655	2	
13*	480007	SEAL, OIL CR- 19599	2	
14*	485003	SLEEVE, BLADE SHAFT SEAL	2	
15*	486001	WASHER, THRUST 6000 SERIES	2	
16*	576006	SNAP RING, VITON # AS-135	2	
17*	578135	O-RING, VITON # AS-135	2	
18*	576007	SNAP RING, VHO-354	1	
19*	10138	SCREW, SHS 1/4 - 20 X 1/2	6	
20*	927048	KEY, WOODRUFF #807 1/4 X 7/8	2	
21	37134	BLADESHAFT ASSEMBLY	1	INCLUDES ITEMS W/*

16", 20", 26" BLADEGUARD ASSY.

16", 20", 26" BLADEGUARD ASSY.

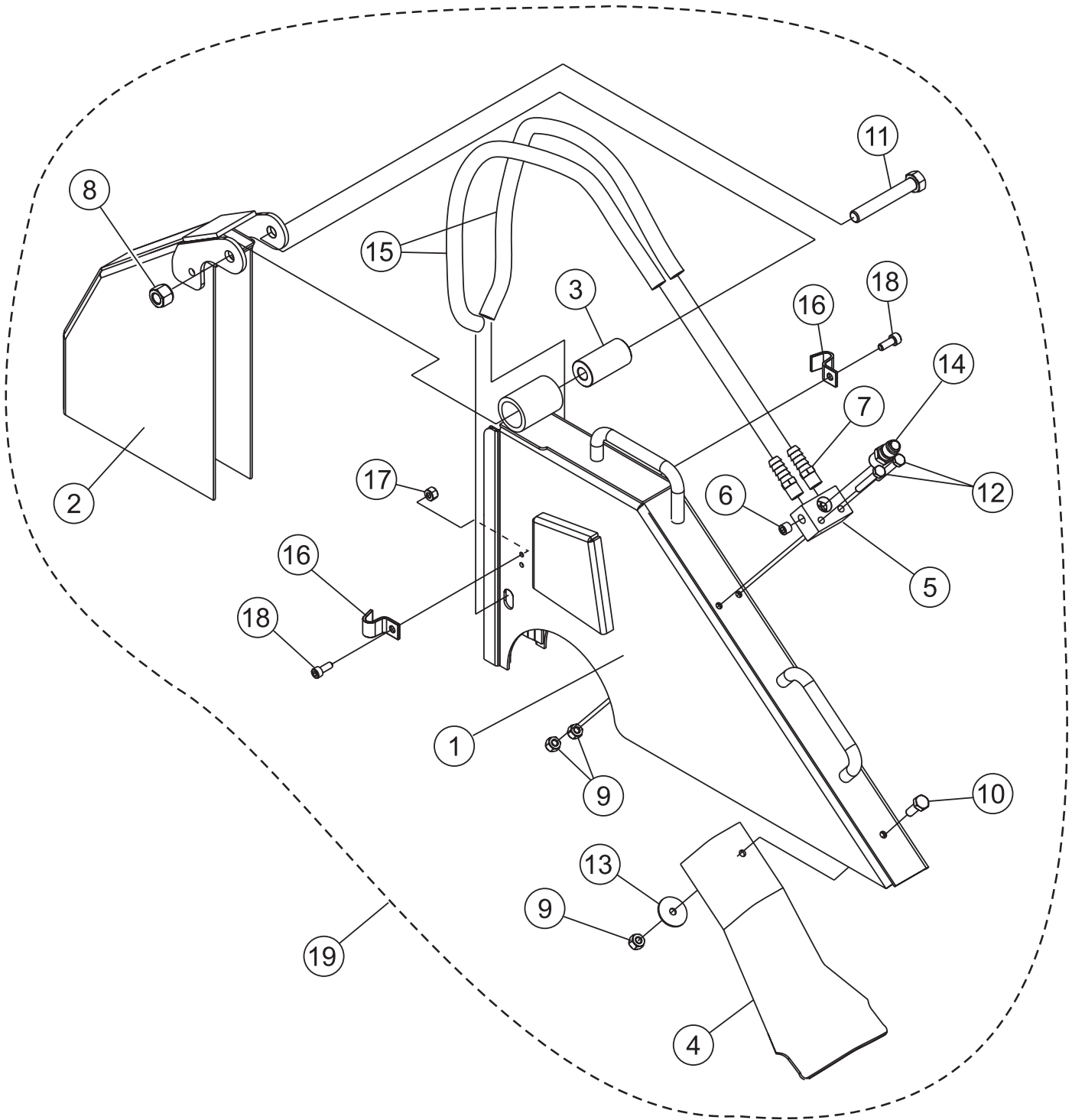

16", 20", 26" BLADEGUARD ASSY.

16", 20", 26" BLADEGUARD ASSY.

<u>NO.</u>	<u>PART NO.</u>	<u>PART NAME</u>	<u>QTY.</u>	<u>REMARKS</u>
1*	200004	BLADEGUARD W/A, 16" REAR HALF	1	
1#	200008	BLADEGUARD W/A, 20" REAR HALF	1	
1\$	200010	BLADEGUARD W/A, 26" REAR HALF	1	
2*	200003	BLADEGUARD W/A, 16" FRONT HALF	1	
2#	200007	BLADEGUARD W/A, 20" FRONT HALF	1	
2\$	200009	BLADEGUARD W/A, 26" FRONT HALF	1	
3*#\$	582040	BUSHING, BLADEGUARD HINGE DELRIN	1	
4*#\$	200019	FLAP,MUD BLADEGUARD	1	SAFETY ITEM
5*#\$	37394	MANIFOLD, WATER SMALL	1	
6*#\$	2113	FITTING, PLUG 1/8MP HEX SKT HD	1	
7*#\$	370456	FITTING, BRASS 6BARB-1/4MP	2	
8*#\$	10176	NUT, NYLOC 1/2-13	1	
9*#\$	10024	NUT, NYLOC 1/4-20	3	
10*#\$	0131 A	SCREW, HHC 1/4 - 20 X 3/4	1	
11*#\$	06503-026	SCREW, HHC 1/2 - 13 X 3-1/4	1	
12*#\$	26250	SCREW, HHC 1/4 - 20 X 1-3/4	2	
13*#\$	10930	WASHER, FENDER 1/4 X 1-1/4	1	
14*#\$	37396	3/8" QC MALE	1	
15*#	37506	HOSE, WATER #6 LP, 16", 20" BLADEGUARD	2	
15\$	37508	HOSE, WATER #6 LP, 26" BLADEGUARD	2	
16*#\$	22129-001	PIPE STRAP 3/8	2	
17*#\$	1618	NUT, NYLOC 10-24	2	
18*#\$	923144	SCREW, SHC 10-24 X 1/2	2	
19	37335	BLADEGUARD ASSY., 16" STD SYS	1	SAFETY ITEM INCLUDES ITEMS W/*
19	37336	BLADEGUARD ASSY., 20" STD SYS	1	SAFETY ITEM INCLUDES ITEMS W/#
19	37337	BLADEGUARD ASSY., 26" STD SYS	1	SAFETY ITEM INCLUDES ITEMS W/\$

30", 36" BLADEGUARD ASSY.

30", 36" BLADE GUARD ASSY.

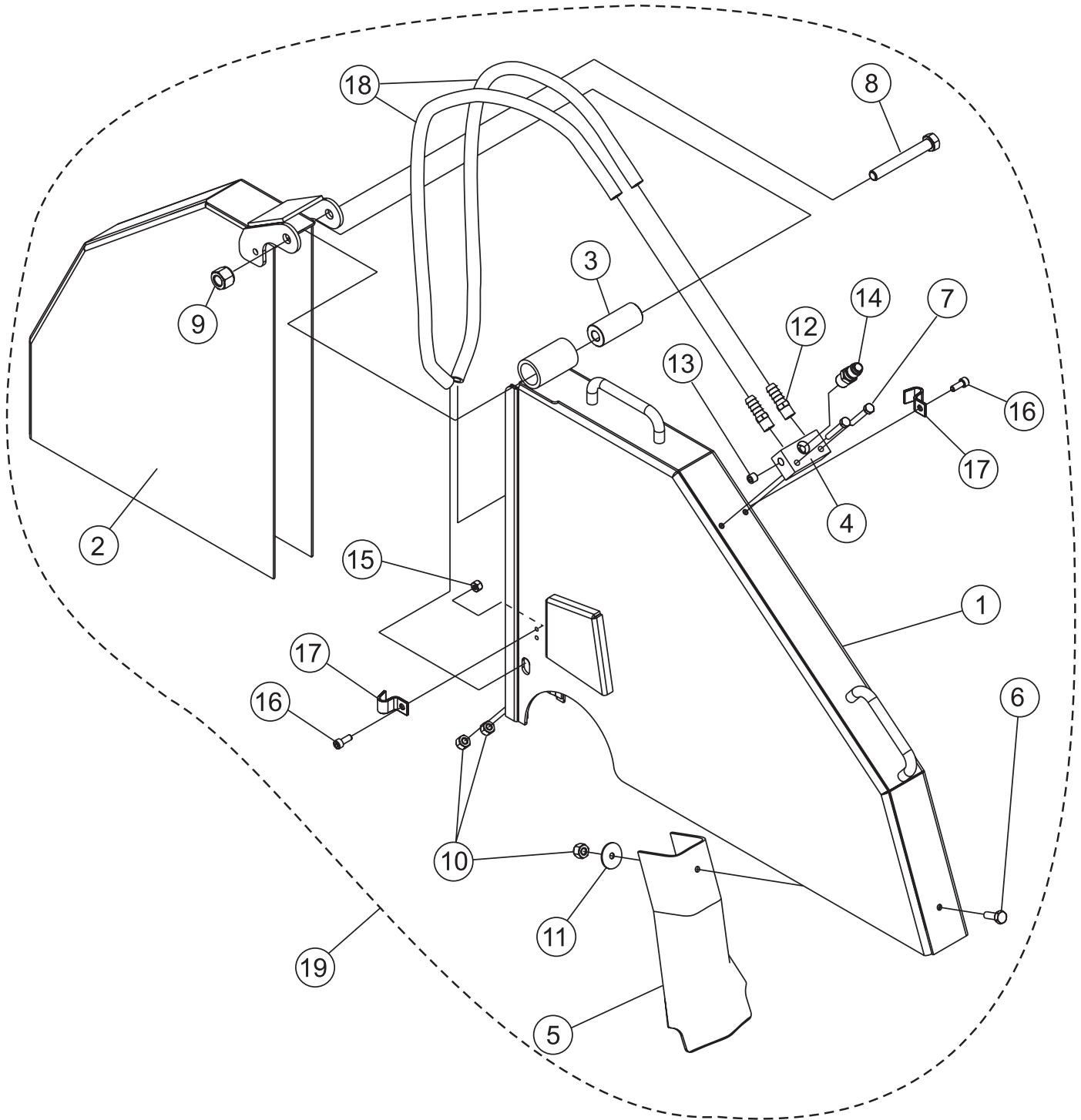

30", 36" BLADEGUARD ASSY.

30", 36" BLADE GUARD ASSY.

<u>NO.</u>	<u>PART NO.</u>	<u>PART NAME</u>	<u>QTY.</u>	<u>REMARKS</u>
1*	200012	BLADEGUARD W/A, 30" REAR HALF	1	
1#	200014	BLADEGUARD W/A, 36" REAR HALF	1	
2*	200011	BLADEGUARD W/A, 30" FRONT HALF	1	
2#	200013	BLADEGUARD W/A, 36" FRONT HALF	1	
3*#	582039	BUSHING, BLADEGUARD HINGE DELRIN	1	
4*#	37395	MANIFOLD, WATER LARGE	1	
5*#	200019	FLAP,MUD BLADEGUARD	1	SAFETY ITEM
6*#	0131 A	SCREW, HHC 1/4 - 20 X 3/4	1	
7*#	26250	SCREW, HHC 1/4 - 20 X 1-3/4	2	
8*#	06503-030	SCREW, HHC 1/2 - 13 X 3-3/4	1	
9*#	10176	NUT, NYLOC 1/2-13	1	
10*#	10024	NUT, NYLOC 1/4-20	3	
11*#	10930	WASHER, FENDER 1/4 X 1-1/4	1	
12*#	370456	FITTING, BRASS 6BARB-1/4MP	2	
13*#	2113	FITTING, PLUG 1/8MP HEX SKT HD	1	
14*#	37396	3/8" QC MALE	1	
15*#	1618	NUT, NYLOC 10-24	2	
16*#	923144	SCREW, SHC 10-24 X 1/2	2	
17*#	22129-001	PIPE STRAP 3/8	2	
18*	37509	HOSE, WATER #6 LP, 30" BLADEGUARD	2	
18#	37510	HOSE, WATER #6 LP, 36" BLADEGUARD	2	
19	37338	BLADEGUARD ASSY., 30" STD SYS	1	SAFETY ITEM INCLUDES ITEMS W/*
19	37339	BLADEGUARD ASSY., 36" STD SYS	1	SAFETY ITEM INCLUDES ITEMS W/#

OPTIONAL WEIGHT KIT ASSY.

OPTIONAL WEIGHT KIT ASSY.

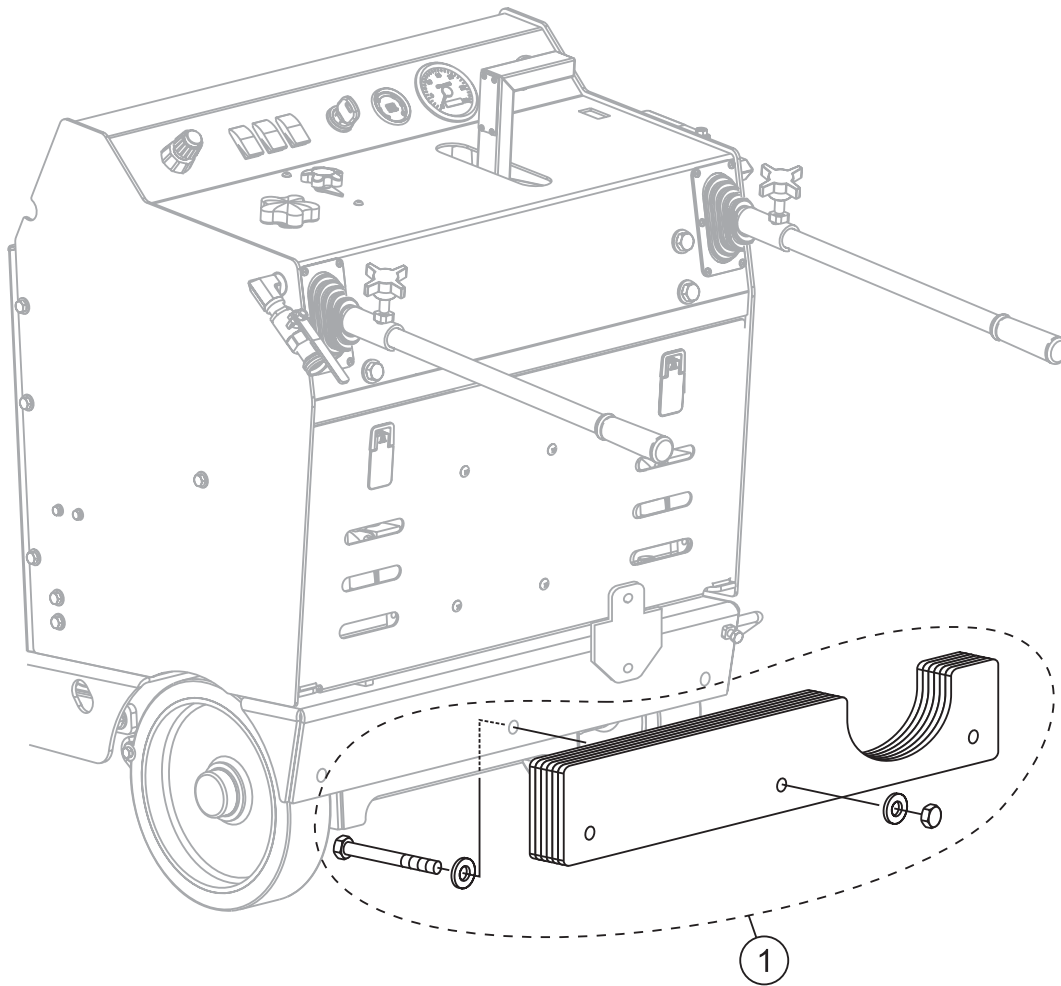

OPTIONAL WEIGHT KIT ASSY.

OPTIONAL WEIGHT KIT ASSY.

<u>NO.</u>	<u>PART NO.</u>	<u>PART NAME</u>	<u>QTY.</u>	<u>REMARKS</u>
1	37829	WEIGHT KIT	1	

STOW

A DIVISION OF MULTIQUIP INC.

Terms and Conditions of Sale STOW Construction Equipment

PAYMENT TERMS

Terms of payment for unit sales are 2% 15 days net 30 days from date of invoice unless otherwise specifically stated on our invoice. Parts invoices have terms of net 10 days. **Minimum parts billing is \$15.00 net.**

Applicable discounts will be computed on merchandise value only. Late charges will be assessed at prevailing rates. Cash discounts cannot be taken on current billings if any previously billed amounts are past due.

FREIGHT POLICY

Freight policy is established to offer customers every advantage possible. Due to bulk freight ratings on some equipment and other shipping considerations, freight policies differ by equipment type. Actual back freight may be charged for shipments originating from other than specified FOB warehouses. **See Freight Policy for details.**

All STOW domestic sales are FOB nearest available designated MQ/STOW warehouse. Export orders are ex-works factory located in Carson, CA or Boise, ID.

Additions to orders already shipped cannot be accepted for freight minimums.

Should STOW elect to make partial shipments of an order originally complying with the "freight allowed" requirements, transportation charges will be absorbed by STOW on any subsequent shipment applying to that order.

All other orders will be shipped collect or prepaid with charges added to the invoice. STOW's responsibility ceases when a signed manifest has been obtained from the carrier, and any claim for shortage or damage must be settled between the consignee and the carrier.

Parts: FOB Carson, California or Boise, Idaho. **See Freight Policy for details and additional discounts.**

DROP SHIPMENTS

STOW reserves the right to refuse Drop Shipments outside the normal service area of the purchasing dealer.

FIELD WAREHOUSES

Field Warehouses are currently located in California, Georgia, Idaho, Iowa, and New Jersey

SPECIAL EXPEDITING SERVICE

The higher of a \$35.00 surcharge or actual costs will be added to the invoice for special handling, including bus shipments, or in cases where STOW personnel must personally deliver the equipment or parts to the carrier.

RETURNED GOODS POLICY

Return shipments may be accepted and credit allowed, subject to the following provisions.

1. A Returned Material Authorization (RMA) must be approved by STOW prior to shipment. Approvals for returned goods must be with just cause and are at the sole discretion of STOW. A copy of the Authorization must accompany the shipment to the designated Warehouse.
2. Parts being returned must be listed as currently supplied on the current parts list.
3. Parts must be in new and resalable condition in the original package, with part numbers clearly marked.
4. Units and accessories must be current models in the latest price list and in new and resalable condition.
5. Special order items are not returnable for credit.
6. Credit on returned parts and units will be issued at actual dealer net price at time of purchase less 15% restocking charge.
7. All returned shipments are to be made to the STOW designated receiving point, freight prepaid at the sender's expense.

The sender will be notified of any material received that does not meet the above provisions. Such material will be held for 30 days from notification pending instructions. If a reply is not received within 30 days, the material will be returned to the sender at his expense with no credit issued.

PRICING, REBATES AND SPECIFICATIONS

Every effort will be made to provide adequate notice of changes; however, prices and equipment specifications are subject to change without notice.

Price changes are effective on a specific date and all orders received on or after that date will be billed at the revised price.

Rebates for price reductions and added charges for price increases will not be made for stock in dealer inventory at the time of a price change.

STOW reserves the right to quote and sell direct to Government agencies and to Original Equipment Manufacturer accounts who use our products as integral parts of their own products.

LIMITATION OF SELLER'S LIABILITY

STOW shall not be liable hereunder for damages in excess of the purchase price of the item with respect to which damages are claimed and in no event shall STOW be liable for loss of profit or good will or for any other special, consequential or incidental damages.

LIMITATION OF WARRANTIES

There are no warranties, express or implied, made by STOW hereunder on Products manufactured or distributed by it except the warranty against defects in material and workmanship on new Products to the original purchaser, as set forth in the STOW New Product Limited Warranty.

Effective: July 15, 2003

STOW

A DIVISION OF MULTIQUIP INC.

Atlanta • Boise • Newark • Quebec, Canada
Manchester, UK • Rio de Janeiro, BR • Puebla, MX

STOW CONSTRUCTION EQUIPMENT

POST OFFICE BOX 6254
CARSON, CALIFORNIA 90749
310-661-4242 • 877-BUY-STOW
FAX: 310-604-9237
E-MAIL: stow@stowmfg.com
www.stowmfg.com

PARTS MANUAL

HERE'S HOW TO GET HELP

PLEASE HAVE THE MODEL AND SERIAL
NUMBER *ON-HAND* WHEN CALLING

PARTS DEPARTMENT

800-427-1244 FAX: 800-672-7877

310-537-3700 FAX: 310-637-3284

SERVICE DEPARTMENT

800-478-1244 FAX: 310-537-4259

310-537-3700

TECHNICAL ASSISTANCE

800-478-1244 FAX: 310-631-5032

WARRANTY DEPARTMENT

800-421-1244, EXT. 279 FAX: 310-537-1173

310-537-3700, EXT. 279

SALES DEPARTMENT

310-661-4242 FAX: 310-604-9237

877-289-7869 (877-BUY-STOW)

© COPYRIGHT 2008, MULTIQIP INC.

Multiquip Inc and the STOW logo are registered trademarks of Multiquip Inc. and may not be used, reproduced, or altered without written permission. All other trademarks are the property of their respective owners and used with permission.

This manual **MUST** accompany the equipment at all times. This manual is considered a permanent part of the equipment and should remain with the unit if resold.

The information and specifications included in this publication were in effect at the time of approval for printing. Illustrations, descriptions, references and technical data contained in this manual are for guidance only and may not be considered as binding. Multiquip Inc. reserves the right to discontinue or change specifications, design or the information published in this publication at any time without notice and without incurring any obligations.

Your Local Dealer is:

STOW
A DIVISION OF MULTIQIP INC.
Atlanta • Boise • Newark • Quebec, Canada
Manchester, UK • Rio de Janeiro, BR • Puebla, MX

MQ STOW CONSTRUCTION EQUIPMENT

A DIVISION OF MULTIQIP INC.

POST OFFICE BOX 6254

CARSON, CA 90749

310-537-3700 • 888-252-MQ STOW [888-252-7869]

FAX: 310-537-1986 • FAX: 800-556-1986

E-MAIL: MQ STOW@multiquip.com • WWW:

stowmfg.com