

OPERATION MANUAL



WHISPERWATT™ SERIES
MODELS
DCA15SPX4F2
DCA15SPXU4F2
60 Hz GENERATORS
(KUBOTA D1503-M DIESEL ENGINE)

INSTRUCTION MANUAL NO. B0844306604

Revision #0 (05/20/26)

To find the latest revision of this publication or associated parts manual, visit our website at:
www.mqpower.com



THIS MANUAL MUST ACCOMPANY THE EQUIPMENT AT ALL TIMES.

PROPOSITION 65 WARNING



TABLE OF CONTENTS

DCA15SPX4F2 DCA15SPXU4F2 60 Hz Generators

- Proposition 65 Warning 2
- Table of Contents..... 3
- Safety Decals 4
- Safety Information 5–10
- Specifications 11
- Dimensions..... 12
- Installation 13–14
- General Information..... 15–16
- Major Components 17
- Control and Operation Panel 18–19
- Output Terminal Panel Familiarization..... 20–22
- Load Application 23
- Terminal Panel Connections/Gauge Reading..... 24
- Inspection/Setup..... 25–28
- Generator Start-Up Procedure 29–30
- Generator Shutdown Procedure..... 31–32
- Maintenance 33–41
- Troubleshooting (Diagnostics)..... 42
- Troubleshooting (Generator) 43
- Troubleshooting (Engine) 44–45
- Generator Wiring Diagram (M0844300104C)..... 46
- Engine Wiring Diagram (M0814100003) 47
- Battery Charger Wiring Diagram (Option) 48
- Engine Block Heater Wiring Diagram (Option) 49

DISCLAIMER:
Product features, descriptions, and specifications are based on published information at the time of publication and are subject to change at any time without notice. Multiquip Inc. and its affiliates reserve the right to change specifications, features, design, and descriptions of products at any time without notice.

SAFETY DECALS

Safety decals are attached to the generator as shown in Figure 1. Keep these safety decals clean at all times. When the safety decals become worn or damaged, contact your nearest dealer or the Multiquip Parts Department.

NOTICE
For safety decal part numbers, refer to the associated parts manual.

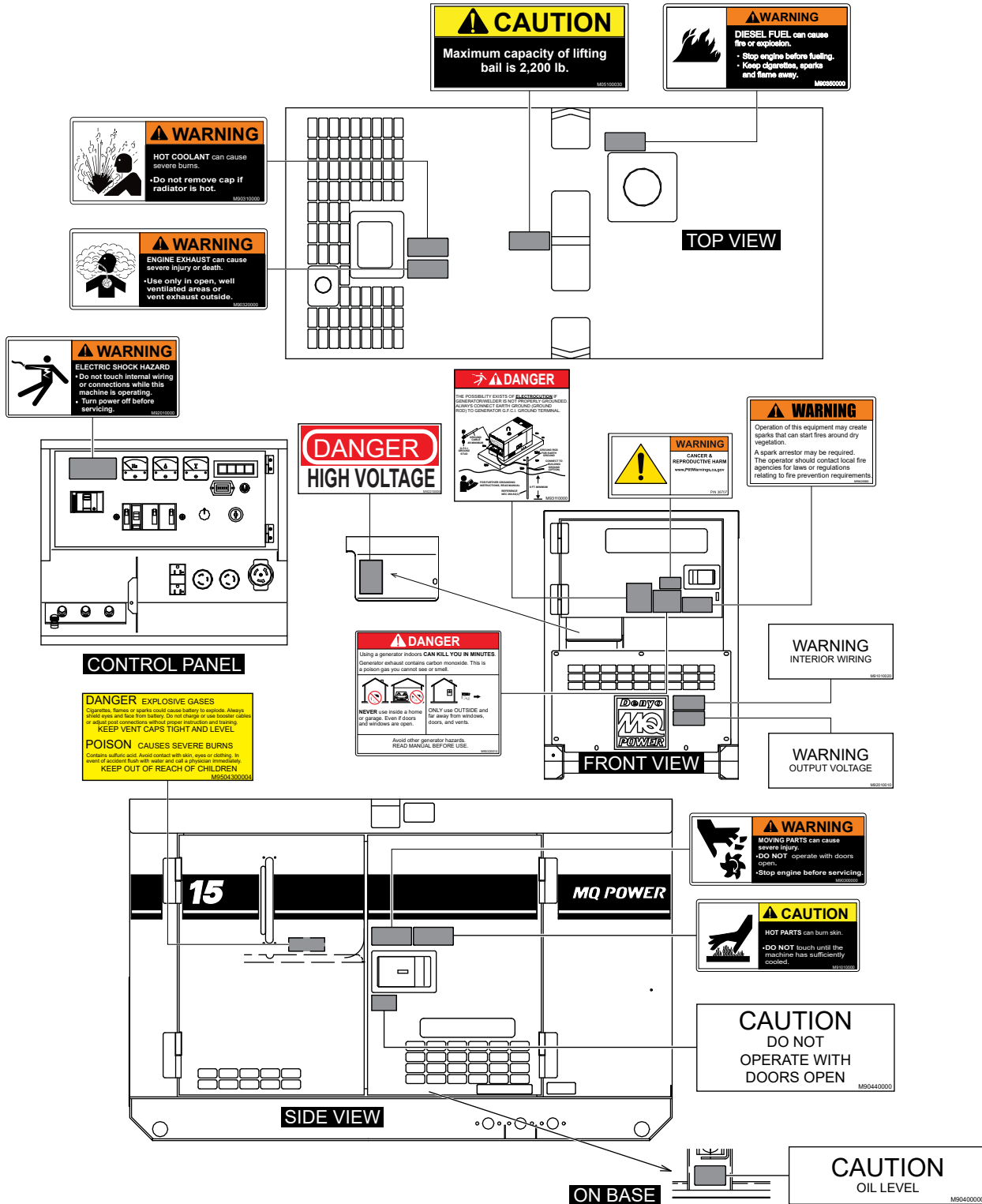

Figure 1. Safety Decals

SAFETY INFORMATION

Do not operate or service the generator before reading the entire manual. Safety precautions should be followed at all times when operating this generator. Failure to read and understand the safety messages and operating instructions could result in injury to yourself and others.







SAFETY MESSAGES

The four safety messages shown below will inform you about potential hazards that could injure you or others. The safety messages specifically address the level of exposure to the operator and are preceded by one of four words: **DANGER**, **WARNING**, **CAUTION** or **NOTICE**.

SAFETY SYMBOLS

 DANGER
<p>Indicates a hazardous situation which, if not avoided, WILL result in DEATH or SERIOUS INJURY.</p>
 WARNING
<p>Indicates a hazardous situation which, if not avoided, COULD result in DEATH or SERIOUS INJURY.</p>
 CAUTION
<p>Indicates a hazardous situation which, if not avoided, COULD result in MINOR or MODERATE INJURY.</p>
NOTICE
<p>Addresses practices not related to personal injury.</p>

Potential hazards associated with the operation of this generator will be referenced with hazard symbols which may appear throughout this manual in conjunction with safety messages.

Symbol	Safety Hazard
	Lethal exhaust gas hazards
	Explosive fuel hazards
	Burn hazards
	Overspeed hazards
	Rotating parts hazards
	Pressurized fluid hazards
	Electric shock hazards

SAFETY INFORMATION

GENERAL SAFETY

⚠ CAUTION

- **NEVER** operate this generator without proper protective clothing, shatterproof glasses, respiratory protection, hearing protection, steel-toed boots and other protective devices required by the job or city and state regulations.





- **NEVER** operate this generator when not feeling well due to fatigue or illness, or when on medication. 
- **NEVER** operate this generator under the influence of drugs or alcohol.



- **ALWAYS** check the generator for loosened threads or bolts before starting.
- **NEVER** use the generator for any purpose other than its intended purposes or applications.

NOTICE

- This generator should only be operated by trained and qualified personnel 18 years of age and older.
- Whenever necessary, replace nameplate, operation and safety decals when they become difficult to read.
- Manufacturer does not assume responsibility for any accident due to equipment modifications. Unauthorized modification of the generator will void all warranties.
- **NEVER** use accessories or attachments that are not recommended by MQ Power for this generator. Damage to the generator and/or injury to the user may result.
- **ALWAYS** know the location of the nearest **fire extinguisher**. 
- **ALWAYS** know the location of the nearest **first aid kit**. 

- **ALWAYS** know the location of the nearest phone or **keep a phone on the job site**. Also, know the phone numbers of the nearest **ambulance, doctor, and fire department**. This information will be invaluable in the case of an emergency.



GENERATOR SAFETY

⚠ DANGER

- **NEVER** operate the generator in an explosive atmosphere or near combustible materials. An explosion or fire could result causing **severe bodily harm or even death**. 

⚠ WARNING

- **NEVER** disconnect any **emergency or safety devices**. These devices are intended for operator safety. Disconnection of these devices can cause **severe injury, bodily harm or even death**. Disconnection of any of these devices will void all warranties.

⚠ CAUTION

- **NEVER** lubricate components or attempt service on a **running generator**.

NOTICE

- **ALWAYS** ensure the generator is on level ground before use.
- **ALWAYS** keep the generator in proper running condition.
- Fix damage to the generator and replace any broken parts immediately.
- **ALWAYS** store the generator properly when it is not being used. The generator should be stored in a clean, dry location out of the reach of children and unauthorized personnel.

SAFETY INFORMATION

ENGINE SAFETY

DANGER

■ The engine fuel exhaust gases contain poisonous carbon monoxide. This gas is colorless and odorless, and can cause **death** if inhaled.

■ The engine of this generator requires an adequate, free flow of cooling air. **NEVER** operate this equipment in any enclosed or narrow area where free flow of the air is restricted. If the air flow is restricted it will cause injury to people and property and serious damage to the equipment or engine.



■ When operating the generator outdoors, **DO NOT** place the generator near doors, windows or vents that could allow carbon monoxide to enter and build up in occupied spaces.

WARNING

■ **NEVER** place hands or fingers inside the engine compartment when the engine is running.

■ **NEVER** operate the engine with heat shields or guards removed.

■ Keep fingers, hands, hair and clothing away from all moving parts to prevent injury.



■ **NEVER** operate the generator with the doors open. Stop the engine before servicing.

■ **DO NOT** remove the radiator cap while the engine is hot. High pressure boiling water will gush out of the radiator and severely scald any persons in the general area of the generator.



■ **DO NOT** remove the coolant drain plug while the engine is hot. Hot coolant will gush out of the coolant tank and severely scald any persons in the general area of the generator.

■ **DO NOT** drain the engine oil while the engine is hot. Hot oil will gush out and severely scald any persons near the generator.

■ Operation of the generator may create sparks that can start fires around dry vegetation. A spark arrestor may be required. The operator should contact local fire agencies for laws or regulations relating to fire prevention requirements.

CAUTION

■ **NEVER** touch the hot exhaust manifold, muffler or cylinder. Allow these parts to cool before servicing the generator.



NOTICE

■ **NEVER** run the engine without an air filter or with a dirty air filter. Severe engine damage may occur. Service the air filter frequently to prevent engine malfunction.

■ **NEVER** tamper with the factory settings of the engine or engine governor. Damage to the engine or generator can result if operating in speed ranges above the maximum allowable.



■ Wet stacking is a common problem with diesel engines which are operated for extended periods with light or no load applied. When a diesel engine operates without sufficient load (less than 30-35% of the rated output), it will not operate at its optimum temperature. This will allow unburned fuel to accumulate in the exhaust system, which can foul the fuel injectors, engine valves and exhaust system, including turbochargers, and reduce the operating performance.

In order for a diesel engine to operate at peak efficiency, it must be able to provide fuel and air in the proper ratio and at a high enough engine temperature for the engine to completely burn all of the fuel.

Wet stacking does not usually cause any permanent damage and can be alleviated if additional load is applied to relieve the condition. It can reduce the system performance and increase maintenance. Applying an increasing load over a period of time until the excess fuel is burned off and the system capacity is reached usually can repair the condition. This can take several hours to burn off the accumulated unburned fuel.

SAFETY INFORMATION

FUEL SAFETY

DANGER

- **NEVER** start the engine near spilled fuel or combustible fluids. Diesel fuel is extremely flammable and its vapors can cause an explosion if ignited.
- **ALWAYS** refuel in a well-ventilated area, away from sparks and open flames.
- **ALWAYS** use extreme caution when working with **flammable** liquids.
- **NEVER** fill the fuel tank while the engine is **running** or **hot**.
- **NEVER** overfill the fuel tank. Spilled fuel can ignite if it comes into contact with hot engine parts or sparks from the ignition system.
- Store fuel in appropriate containers, in well-ventilated areas and away from sparks and flames.
- **NEVER** use fuel as a cleaning agent.
- **NEVER** smoke around or near the equipment. Fire or explosion could result from fuel vapors or if fuel is spilled on a hot engine.



TOWING SAFETY

CAUTION

- Check with your local county or state safety towing regulations, in addition to meeting **Department of Transportation (DOT) Safety Towing Regulations**, before towing your generator.
- Refer to the MQ Power trailer manual for additional safety information.
- In order to reduce the possibility of an accident while transporting the generator on public roads, **ALWAYS** make sure that the trailer that supports the generator and the towing vehicle are both mechanically sound and in good operating condition.
- **ALWAYS** shut down the engine before transporting.



- Make sure the hitch and coupling of the towing vehicle are rated equal to or greater than the trailer **gross vehicle weight rating**.
- **ALWAYS** inspect the hitch and coupling for wear. **NEVER** tow a trailer with defective hitches, couplings, chains, etc.
- Check the tire air pressure on both the towing vehicle and the trailer. **Inflate trailer tires as indicated on side wall of tire**. Also check the tire tread wear on both vehicles.
- **ALWAYS** make sure the trailer is equipped with **safety chains**.
- **ALWAYS** properly attach the trailer's safety chains to the towing vehicle.
- **ALWAYS** make sure the vehicle and trailer directional, backup, brake, and trailer lights are connected and working properly.
- DOT requirements include the following:
 - Connect and test electric brake operation.
 - Secure portable power cables in cable tray with tie wraps.
- The maximum speed for highway towing is **55 MPH** unless posted otherwise. Recommended off-road towing is not to exceed **15 MPH** or less depending on the type of terrain.
- Avoid sudden stops and starts. These can cause skidding or jackknifing. Smooth, gradual starts and stops will improve towing.
- Avoid sharp turns to prevent rolling.
- The trailer should be adjusted to a level position at all times when towing.
- Raise and lock the trailer wheel stand in the upright position when towing.
- Place **chock blocks** underneath the wheels to prevent **rolling** while parked.
- Place **support blocks** underneath the trailer's bumper to prevent **tipping** while parked.
- Use the trailer's swivel jack to adjust the trailer height to a level position while parked.

SAFETY INFORMATION

ELECTRICAL SAFETY

DANGER

- **NEVER** touch the output terminals during operation. Contact with the output terminals during operation can cause **electrocution, electrical shock, or burn**.



- The electrical voltage required to operate the generator can cause **severe injury or even death** through physical contact with live circuits. Turn the generator and all circuit breakers **OFF** before performing maintenance on the generator or making contact with the output terminals.

- **NEVER** insert any objects into the output receptacles during operation. This is extremely dangerous. The possibility exists of **electrical shock, electrocution or death**.



- Backfeed to a utility system can cause **electrocution** and/or property damage. **NEVER** connect the generator to a building's electrical system without a transfer switch or other approved device. All installations should be performed by a **licensed electrician** in accordance with all applicable laws and electrical codes. Failure to do so could result in electrical shock or burn, causing **serious injury or even death**.



Power Cord/Cable Safety

DANGER

- **NEVER** let power cords or cables **lay in water**.
- **NEVER** stand in water while AC power from the generator is being transferred to a load.
- **NEVER** use **damaged** or **worn** cables or cords when connecting equipment to the generator. Inspect the insulation for cuts.
- **NEVER** grab or touch a live power cord or cable with wet hands. The possibility exists of **electrical shock, electrocution or death**.

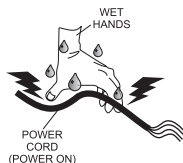

- Make sure power cables are securely connected to the generator's output receptacles. Incorrect connections may cause electrical shock and damage to the generator.

NOTICE

- **ALWAYS** make certain that the proper power or extension cord has been selected for the job. See the Cable Selection Chart in this manual.

Grounding Safety

DANGER

- **ALWAYS** make sure that electrical circuits are properly grounded to a suitable earth ground (ground rod) per the National Electrical Code (NEC) and local codes before operating the generator. **Severe injury or death by electrocution** can result from operating an ungrounded generator.
- **NEVER** use gas piping as an electrical ground.

BATTERY SAFETY

DANGER

- **DO NOT** drop the battery. There is a possibility that the battery will explode.
- **NEVER** expose the battery to open flames, sparks, cigarettes, etc. The battery contains combustible gases and liquids. If these gases and liquids come into contact with a flame or spark, an explosion could occur.



WARNING

- **ALWAYS** wear safety glasses when handling the battery to avoid eye irritation. The battery contains acids that can cause injury to the eyes and skin.
- Use well-insulated gloves when picking up the battery.
- **ALWAYS** keep the battery charged. If the battery is not charged, combustible gas will build up.
- **ALWAYS** recharge the battery in a well-ventilated environment to avoid the risk of a dangerous concentration of combustible gases.
- If the battery liquid (dilute sulfuric acid) comes into contact with **clothing or skin**, rinse skin or clothing immediately with plenty of water.



SAFETY INFORMATION

- If the battery liquid (dilute sulfuric acid) comes into contact with **eyes**, rinse eyes immediately with plenty of water and contact the nearest doctor or hospital to seek medical attention.

CAUTION

- **ALWAYS** disconnect the **NEGATIVE** battery terminal before performing service on the generator.
- **ALWAYS** keep battery cables in good working condition. Repair or replace all worn cables.

ENVIRONMENTAL SAFETY/DECOMMISSIONING

NOTICE

Decommissioning is a controlled process used to safely retire a piece of equipment that is no longer serviceable. If the equipment poses an unacceptable and unrepairable safety risk due to wear or damage or is no longer cost effective to maintain (beyond life-cycle reliability) and is to be decommissioned (demolition and dismantlement), be sure to follow the rules below:

- **NEVER** pour waste or oil directly onto the ground, down a drain, or into any water source.
- Contact your country's Department of Public Works or recycling agency in your area and arrange for proper disposal of any electrical components, waste or oil associated with this equipment.
- When the life cycle of this equipment is over, remove the battery and bring it to an appropriate facility for lead reclamation. Use safety precautions when handling batteries that contain sulfuric acid.
- When the life cycle of this equipment is over, it is recommended that the frame and all other metal parts be sent to a recycling center.



Metal recycling involves the collection of metal from discarded products and its transformation into raw materials to use in manufacturing a new product.

Recyclers and manufacturers alike promote the process of recycling metal. Using a metal recycling center promotes energy cost savings.

EMISSIONS INFORMATION

NOTICE

The diesel engine used in this equipment has been designed to reduce harmful levels of carbon monoxide (CO), hydrocarbons (HC), and nitrogen oxides (NOx) contained in diesel exhaust emissions.

This engine has been certified to meet US EPA evaporative emissions requirements in the installed configuration.

Attempting to modify or make adjustments to the engine emission system by unauthorized personnel without proper training could damage the equipment or create an unsafe condition.

Additionally, modifying the fuel system may adversely affect evaporative emissions, resulting in fines or other penalties.

Emission Control Label

The emission control label is an integral part of the emission system and is strictly controlled by regulations.

The label must remain with the engine for its entire life.

If a replacement emission label is needed, please contact your authorized engine distributor.

SPECIFICATIONS

Table 1. Generator Specifications		
Model	DCA15SPX4F2	DCA15SPXU4F2
Type	Revolving field, self-ventilated, open protected type synchronous generator	
Phase	1	
Standby Output	13.7 kW (13.7 kVA)	
Prime Output	13 kW (13 kVA)	
Voltage (L–L/L–N)	240/120	
Power Factor	1.0	
Frequency	60 Hz	
Speed	1,800 rpm	
Dry Weight	1,179.5 lb. (535 kg)	
Wet Weight	1,367.9 lb. (620 kg)	
Table 2. Engine Specifications		
Model	Kubota D1503-M	
Type	4-cycle, water-cooled, swirl combustion chamber type	
No. of Cylinders	3	
Bore × Stroke	3.27 in. × 3.64 in. (83 mm × 92 mm)	
Displacement	91.4 cu. in. (1,499 cc)	
Rated Output	18.4 hp @ 1,800 rpm	
Starting	Electric	
Coolant Capacity	1.85 gal. (7.0 liters)	
Lube Oil Capacity	1.48 gal. (5.6 liters)	
Lube Oil Type	API classification CF, CF-4, CG-4, CH-4, or CI-4	
Fuel Tank Capacity	16.4 gal. (62 liters)	
Fuel Type	#2 diesel fuel (ultra-low sulfur diesel fuel only)	
Fuel Consumption	1.09 gal. (4.1 L)/hr. at full load	0.80 gal. (3.0 L)/hr. at 3/4 load
	0.64 gal. (2.4 L)/hr. at 1/2 load	0.41 gal. (1.6 L)/hr. at 1/4 load
Battery	80D26R	

DIMENSIONS

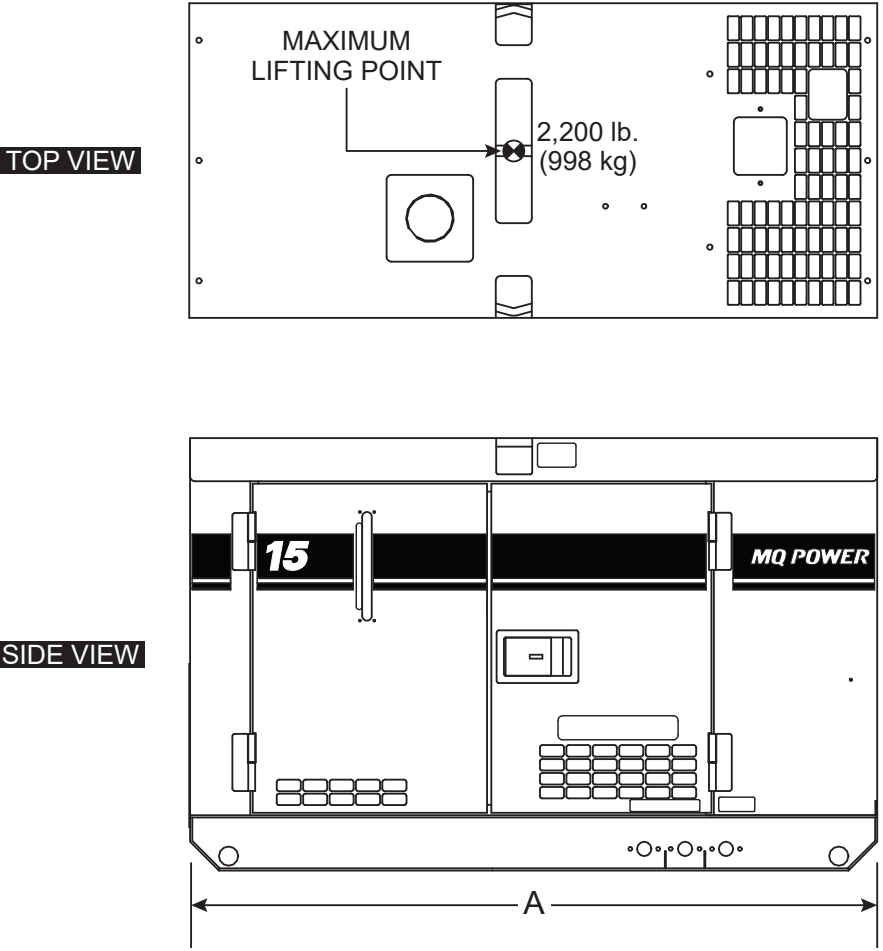

Figure 2. Dimensions

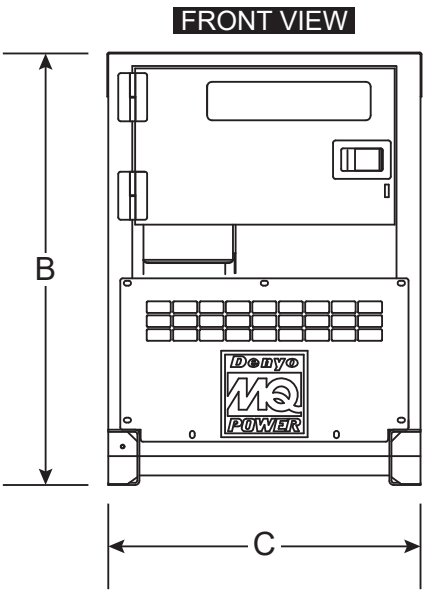

Table 3. Dimensions	
Reference Letter	Dimension in. (mm)
A	56.30 (1,430)
B	35.43 (900)
C	25.59 (650)

GENERATOR GROUNDING

ALWAYS refer to Article 250 (Grounding and Bonding) of the National Electrical Code (NEC).

NOTICE
ALWAYS check with state, province, district, and municipalities for electrical grounding requirements before using the generator.

Connecting The Ground

Consult with local electrical and safety codes for proper connection based on condition of use. Refer to the Conductor Grounding Table, Article 250 of the NEC handbook.

EXAMPLE of how to ground the unit (Figure 3) if the condition of use requires such a device:

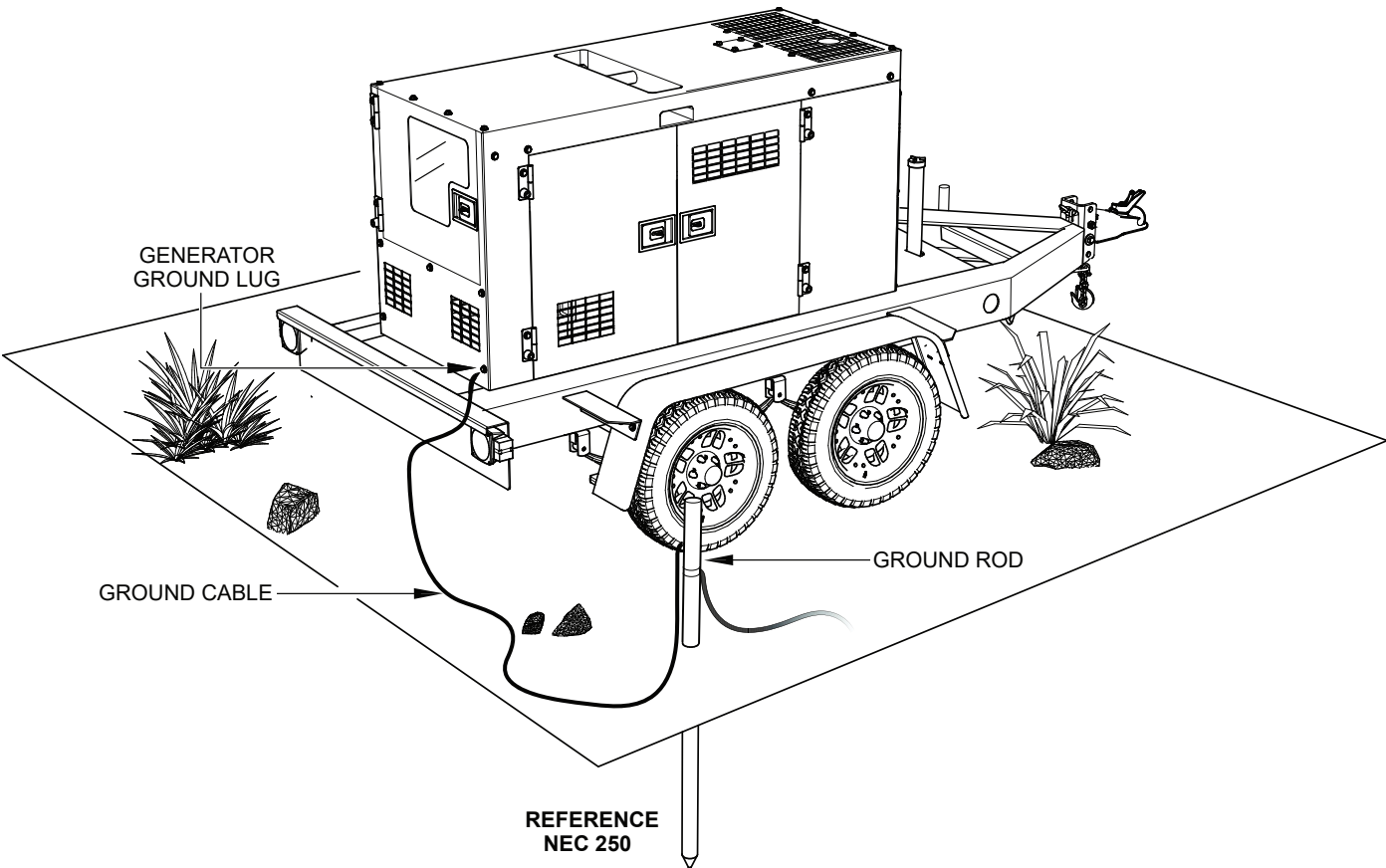

Figure 3. Typical Generator Grounding Application

NOTICE
Trailer-mounted generators are the sole responsibility of MQ Power.

OUTDOOR INSTALLATION

Install the generator in an area that is free of debris, bystanders, and overhead obstructions. Make sure the generator is on secure, level ground so that it cannot slide or shift around. Also, install the generator in a manner so that the exhaust will not be discharged in the direction of nearby homes.

The installation site must be relatively free from moisture and dust. All electrical equipment should be protected from excessive moisture. Failure to do so will result in deterioration of the insulation and will result in short circuits and grounding.

Foreign materials such as dust, sand, lint, and abrasive materials have a tendency to cause excessive wear to engine and alternator parts.

CAUTION

Pay close attention to ventilation when operating the generator inside tunnels and caves. The engine exhaust contains noxious elements. Engine exhaust must be routed to a ventilated area.

INDOOR INSTALLATION

Exhaust gases from diesel engines are extremely poisonous. Whenever an engine is installed indoors the exhaust fumes must be vented to the outside. The engine should be installed at least two feet from any outside wall. Using an exhaust pipe which is too long or too small can cause excessive back pressure which will cause the engine to heat excessively and possibly burn the valves.

MOUNTING

The generator must be mounted on a solid foundation (such as concrete) and set firmly on the foundation to isolate vibration of the generator when it is running. The generator must be mounted at least 6 inches above the floor or grade level as referenced in the National Fire Protection Association handbook (NFPA 110, Chapter 7, Section 7.4).

DO NOT remove the metal skids on the bottom of the generator. They are to resist damage to the bottom of the generator and to maintain alignment.

GENERAL INFORMATION

GENERATOR

This generator is designed as a high-quality, portable (requiring a trailer for transport) power source for telecom sites, lighting facilities, power tools, submersible pumps, and other industrial and construction machinery.

CONTROL AND OPERATION PANEL

The **control and operation panel** is provided with the following:

- Warning Lamp Unit Assembly
 - Pre-Heat Lamp
 - Oil Pressure Alarm Lamp
 - Water Temperature Alarm Lamp
 - Battery Charging Alarm Lamp
 - Preheat Lamp
- Engine Speed Switch
- Frequency Meter (Hz)
- AC Ammeter (A)
- AC Voltmeter (V)
- Voltage Regulator
- Ignition/Starter Switch
- Hour Meter
- 3-Pole, 70-Amp Main Circuit Breaker
- 1-Pole, 20-Amp Circuit Breaker (for 5-20R receptacle)
- 1-Pole, 30-Amp Circuit Breaker (for L5-30R receptacle)
- 2-Pole, 30-Amp Circuit Breaker (for L6-30R receptacle)
- 2-Pole, 50-Amp Circuit Breaker (for CS6369 receptacle)

CONTROL BOX (located behind control panel)

The **control box** is provided with the following:

- Automatic Voltage Regulator
- Current Transformers
- Voltage Rectifier
- Overcurrent Relay
- Starter Relay

OUTPUT TERMINAL PANEL

The **output terminal panel** is provided with the following:

- 120V GFCI Output Receptacle (5-20R)
- 120V Output Receptacle (L5-30R)
- 240V Output Receptacle (L6-30R)
- 240/120V Output Receptacle (CS6369)
- Three Output Terminal Lugs (1Ø power)
- GFCI Ground Terminal
- Enclosure Ground Terminal
- Battery Charger (Option)
- Engine Block Heater (Option)
- Emergency Stop Switch (Option)

OPEN-DELTA EXCITATION SYSTEM

Each generator is equipped with a state-of-the-art, open-delta excitation system. The open-delta system consists of an electrically independent winding wound among stationary windings of the AC output section.

There are four connections of the open delta—A, B, C, and D. During steady-state loads, the power from the voltage regulator is supplied from the parallel connections of A to B, A to D, and C to D. These three phases of the voltage input to the voltage regulator are then rectified and are the excitation current for the exciter section.

When a heavy load such as a motor starting or a short circuit occurs, the automatic voltage regulator (AVR) switches the configuration of the open delta to the series connection of B to C. This has the effect of adding the voltages of each phase to provide higher excitation to the exciter section and thus better voltage response during the application of heavy loads.

The connections of the AVR to the AC output windings are for sensing only. No power is required from these windings.

The open-delta design provides virtually unlimited excitation current, offering maximum motor-starting capabilities. The excitation does not have a 'fixed ceiling' and responds according to the demands of the required load.

ENGINE

This generator is powered by a 4-cycle, water-cooled, swirl combustion chamber type Kubota D1503-M diesel engine. This engine is designed to meet every performance requirement for the generator. Refer to Table 2 for engine specifications.

In keeping with MQ Power's policy of constantly improving its products, the specifications quoted herein are subject to change without prior notice.

MICROPROCESSOR CONTROL SYSTEM

A microprocessor controls the speed (RPM) of the engine. When the engine demand increases or decreases, the microprocessor system regulates the frequency variation to $\pm 0.25\%$.

EXTENSION CABLES

When electrical power is to be provided to various tools or loads at some distance from the generator, extension cords are normally used. Cables should be sized to allow for distance in length and amperage so that the voltage drop between the generator and point of use (load) is held to a minimum. Use the cable selection chart (Table 6) as a guide for selecting the proper extension cable size.

MAJOR COMPONENTS

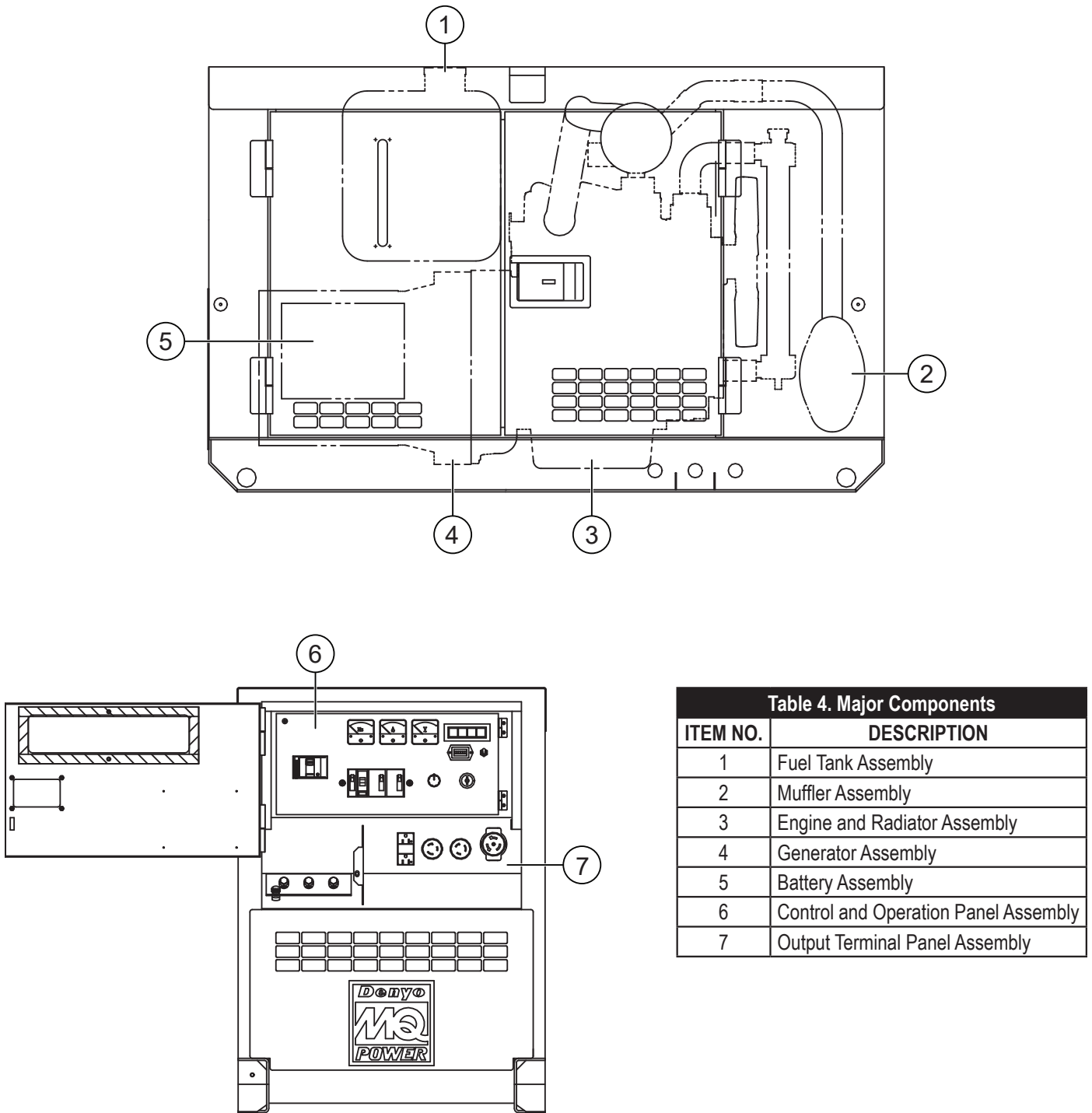

Table 4. Major Components	
ITEM NO.	DESCRIPTION
1	Fuel Tank Assembly
2	Muffler Assembly
3	Engine and Radiator Assembly
4	Generator Assembly
5	Battery Assembly
6	Control and Operation Panel Assembly
7	Output Terminal Panel Assembly

Figure 4. Major Components

CONTROL AND OPERATION PANEL

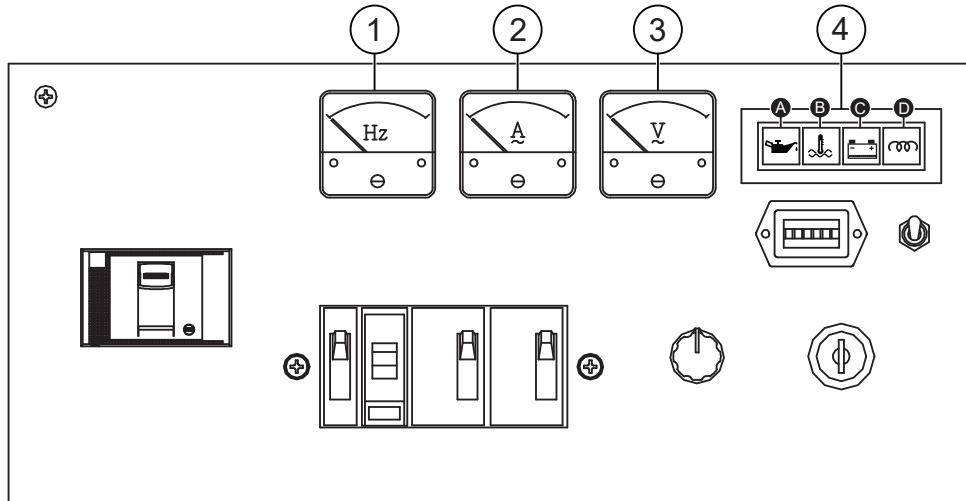

Figure 5. Control And Operation Panel

The definitions below describe the controls and functions of the **control and operation panel** (Figure 5).

1. **Frequency Meter** — Indicates the output frequency in hertz (Hz). Normally 60 Hz.
2. **AC Ammeter** — Indicates the amount of current flowing to the load connected to the output terminals.
3. **AC Voltmeter** — Indicates the phase-to-phase voltage of the output terminals.
4. **Engine Warning Lamp Module** — This module displays the following engine alarms: oil pressure, water temperature, battery charging and pre-heat.

- A. **Oil Pressure Alarm Lamp** — During normal operation of the generator this lamp will remain **OFF**. When the ignition switch is placed in the RUN position to start the engine, the lamp will turn **ON**. When the oil pressure rises after start-up the lamp will turn **OFF**.



If this lamp turns **ON** during normal operation of the generator, the emergency shutdown system will stop the engine automatically.

- B. **Water Temperature Alarm Lamp** — This lamp turns **ON** when the cooling water temperature rises abnormally. If this lamp turns **ON** during normal operation of the generator, the emergency shutdown system will stop the engine automatically.



- C. **Battery Charging Alarm Lamp** — This lamp turns **ON** when the output voltage of the alternator drops below a set value. If this lamp turns **ON** during normal operation, the emergency shutdown system will immediately stop the engine.

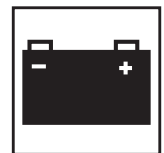

- D. **Preheat Lamp** — This lamp will turn **ON** when the Starter switch is placed in the Preheat position. When the preheat cycle is completed, the lamp will turn **OFF** and the engine can be started. In addition, this lamp will flash to indicate an engine fault condition. Refer to the **Troubleshooting** section of this manual for engine fault lamp codes.

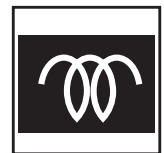

CONTROL AND OPERATION PANEL

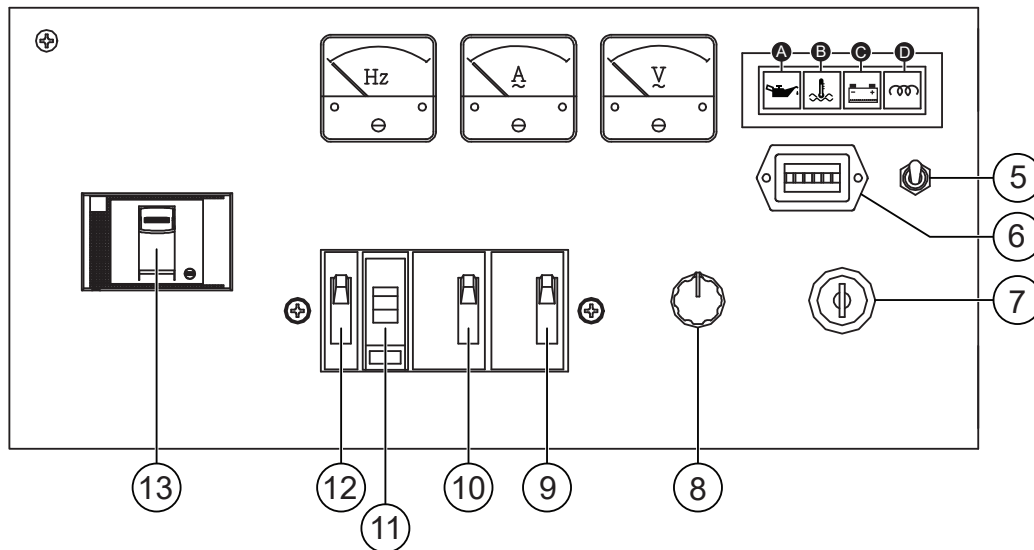

Figure 6. Control And Operation Panel (Cont.)

5. **Engine Speed Switch** — Controls the speed of the engine (low or high).
6. **Hour Meter** — Indicates the total running time of the engine.
7. **Ignition/Starter Switch** — Four-position switch: STOP, RUN, PREHEAT, and START. Insert the ignition key to start the engine.
8. **Voltage Regulator** — Allows manual adjustment of the generator's output voltage.
9. **Circuit Breaker** — Two-pole, 50-amp breaker protects the CS6369 receptacle.
10. **Circuit Breaker** — Two-pole, 30-amp breaker protects the L6-30R receptacle.
11. **Circuit Breaker** — Single-pole, 30-amp breaker protects the L5-30R receptacle.
12. **Circuit Breaker** — Single-pole, 20-amp breaker protects the GFCI 5-20R receptacle.
13. **Main Circuit Breaker** — Three-pole, 70-amp main circuit breaker connects or disconnects the generator output from the output receptacles and protects the generator from short circuits or overcurrent.

OUTPUT TERMINAL PANEL FAMILIARIZATION

OUTPUT TERMINAL PANEL

The **output terminal panel** (Figure 7) shown below is provided for the connection of electrical loads.

NOTICE

Output Terminal Bolt Torque: 65.0 lbf·in (7.4 N·m)

OUTPUT TERMINAL FAMILIARIZATION

The output terminal panel is provided with the following:

- One (1) 240/120-volt, 50-amp, CS6369 output receptacle
- One (1) 240-volt, 30-amp, L6-30R output receptacle
- One (1) 120-volt, 30-amp, L5-30R output receptacle
- One (1) 120-volt, 20-amp, GFCI 5-20R output receptacle
- Four (4) output terminal lugs (U, N, V, Ground)

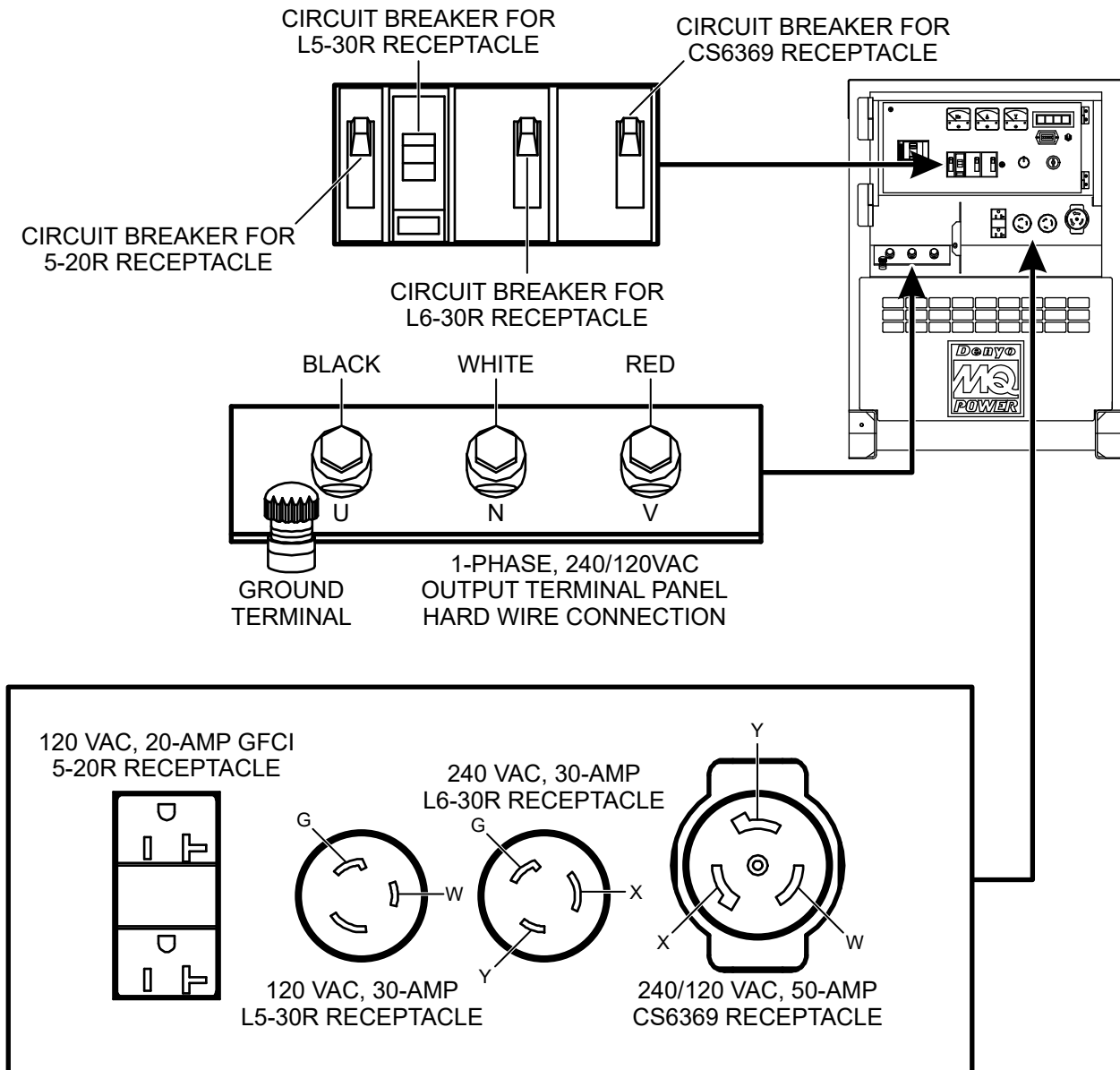

Figure 7. Output Terminal Panel

OUTPUT TERMINAL PANEL FAMILIARIZATION

120-Volt AC GFCI Receptacle

NOTICE

It is recommended that the GFCI receptacle be tested when the generator is initially uncrated. The receptacle should then be tested daily at startup.

A 120-volt, 20-amp GFCI (duplex NEMA 5-20R) AC receptacle (Figure 8) is located on the output terminal panel. This receptacle is protected by a 20-amp circuit breaker which is located on the control and operation panel.

Press the **Reset button** (Figure 8) in the center of the GFCI receptacle to reset the receptacle after it has been tripped. Press the **Test button** to check the GFCI function. The receptacle should be tested at least once a month. Refer to the **Maintenance** section for further testing of the GFCI receptacle.

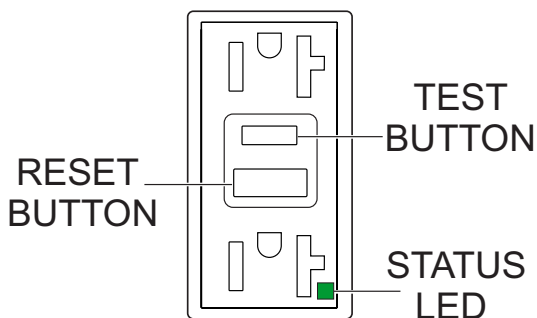

Figure 8. 120-Volt GFCI Receptacle

Twist-Lock AC Receptacles

There are **three twist-lock AC receptacles** (Figure 9) located on the output terminal panel:

- A. 120-volt, 30-amp, L5-30R receptacle protected by a 30-amp circuit breaker
- B. 240-volt, 30-amp, L6-30R receptacle protected by a 30-amp circuit breaker
- C. 240/120-volt, 50-amp, CS6369 receptacle protected by a 50-amp circuit breaker.

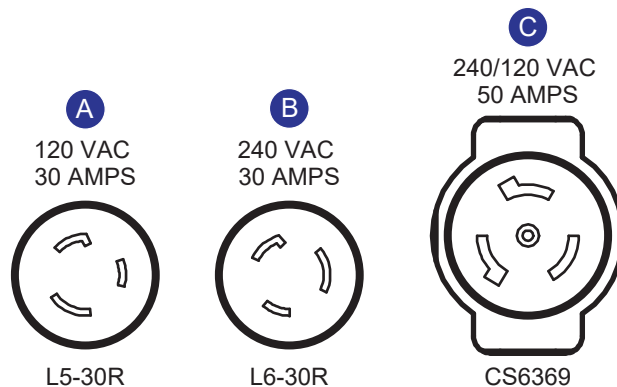

Figure 9. Twist-Lock Receptacles

The corresponding circuit breakers for these receptacles are located on the control and operation panel (Figure 6).

NOTICE

The GFCI and twist-lock power receptacles can **only** be accessed when both the main and corresponding circuit breakers are in the **ON** position.

OUTPUT TERMINAL PANEL FAMILIARIZATION

CONNECTING LOADS

Loads can be connected to the generator via the **output terminals** or **convenience receptacles** (Figure 10). Make sure to read the operation manual before attempting to connect a load to the generator.

To protect the output receptacles from overload, a 3-pole, 70-amp, main circuit breaker is provided. **ALWAYS** place **ALL** circuit breakers in the **OFF** position prior to starting the engine.

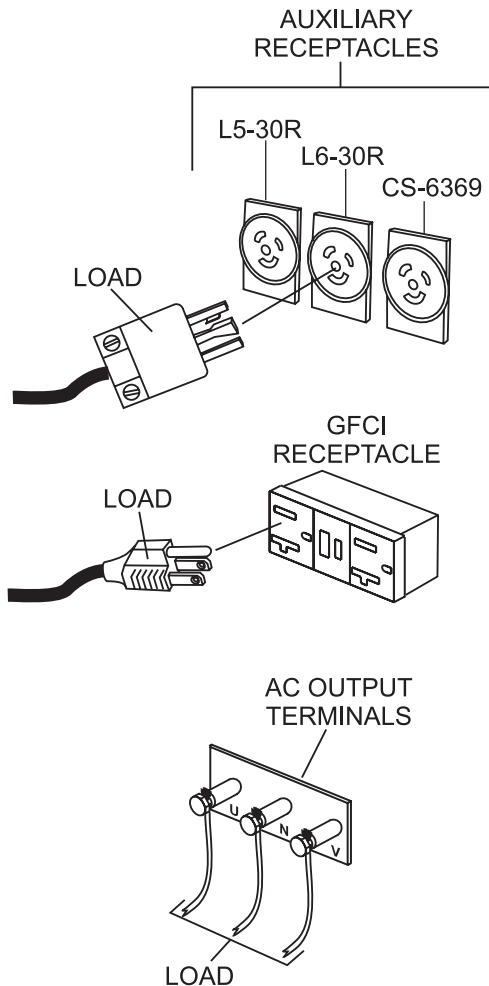

Figure 10. Connecting Loads

OVERCURRENT RELAY

An **overcurrent relay** (Figure 11) is connected to the main circuit breaker. In the event of an overload, both the circuit breaker and the overcurrent relay may trip. If the circuit breaker cannot be reset, the **Reset button** on the overcurrent relay must be pressed. The overcurrent relay is located in the control box.

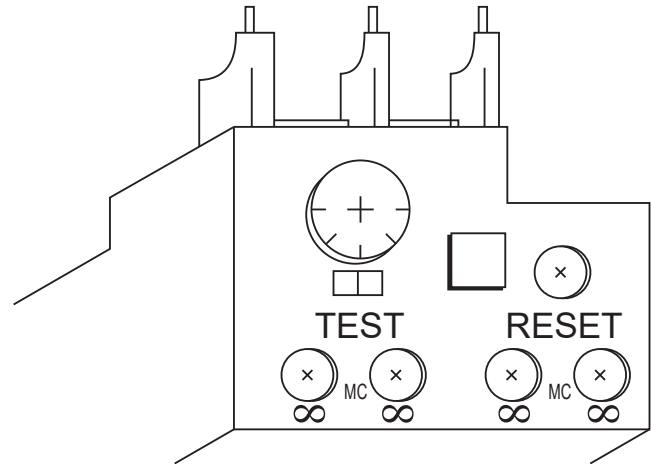

Figure 11. Overcurrent Relay

NOTICE

The overcurrent relay monitors the current flowing from the U, N, and V output terminal lugs to the load. In the event of a short circuit or overcurrent condition, it will automatically trip the 70-amp main circuit breaker.

To restore power to the output terminal panel, press the Reset button on the overcurrent relay and place the main circuit breaker in the closed (ON) position.

LOAD APPLICATION

SINGLE-PHASE LOAD

Always be sure to check the nameplate on the generator and equipment to ensure the wattage, amperage, frequency, and voltage requirements are satisfactorily supplied by the generator for operating the equipment.

Generally, the wattage listed on the nameplate of the equipment is its rated output. Equipment may require 130–150% more wattage than the rating on the nameplate, as the wattage is influenced by the efficiency, power factor, and starting system of the equipment.

NOTICE

If wattage is not given on the equipment's nameplate, approximate wattage may be determined by multiplying the nameplate voltage by the nameplate amperage.

$$\text{WATTS} = \text{VOLTAGE} \times \text{AMPERAGE}$$

The power factor of this generator is 1.0. See Table 5 below when connecting loads.

Table 5. Power Factor By Load

Type of Load	Power Factor
Single-phase induction motors	0.4–0.75
Electric heaters, incandescent lamps	1.0
Fluorescent lamps, mercury lamps	0.4–0.9
Electronic devices, communication equipment	1.0
Common power tools	0.8

Table 6. Cable Selection (60 Hz, Single-Phase Operation)

Current in Amperes	Load in Watts		Maximum Allowable Cable Length			
	At 100 Volts	At 200 Volts	#10 Wire	#12 Wire	#14 Wire	#16 Wire
2.5	300	600	1,000 ft.	600 ft.	375 ft.	250 ft.
5	600	1,200	500 ft.	300 ft.	200 ft.	125 ft.
7.5	900	1,800	350 ft.	200 ft.	125 ft.	100 ft.
10	1,200	2,400	250 ft.	150 ft.	100 ft.	
15	1,800	3,600	150 ft.	100 ft.	65 ft.	
20	2,400	4,800	125 ft.	75 ft.	50 ft.	

CAUTION: Equipment damage can result from low voltage.

NOTICE

Motors and motor-driven equipment draw much greater current for starting than during operation.

An inadequately sized connecting cable which cannot carry the required load can cause a voltage drop which can burn out the appliance or tool and overheat the cable. See Table 6.

- When connecting a resistance load such as an incandescent lamp or electric heater, a capacity of up to the generating set's rated output (kW) can be used.
- When connecting a fluorescent or mercury lamp, a capacity of up to the generating set's rated output (kW) multiplied by 0.6 can be used.
- When connecting an electric drill or other power tools, pay close attention to the required starting current capacity.
- When connecting ordinary power tools, a capacity of up to the generating set's rated output (kW) multiplied by 0.8 can be used.

DANGER

Before connecting this generator to any building's electrical system, a **licensed electrician** must install an **isolation (transfer) switch**. Serious damage to the building's electrical system may occur without this transfer switch.

MAXIMUM AMPS

Table 7 shows the **maximum** amps the generator can provide. **DO NOT** exceed the maximum amps as listed.

Table 7. Generator Maximum Amps

Rated Voltage	Maximum Amps
120 volts (UNV terminals)	58.3 × 2
240 volts (UNV terminals)	58.3
120 volts (GFCI 5-20R receptacle)	20
120 volts (L5-30R receptacle)	30
240 volts (L6-30R receptacle)	30
120/240 volts (CS6369 receptacle)	50

TERMINAL PANEL CONNECTIONS/GAUGE READING

UNV TERMINAL OUTPUT VOLTAGES

240/120V output voltages can be obtained using the output terminal lugs.

The voltage regulator (Figure 13) allows the user to increase or decrease the selected voltage.

Single-Phase 120-Volt UNV Output Terminal Voltage

1. Connect the load wires to the output terminal lugs as shown in Figure 12.

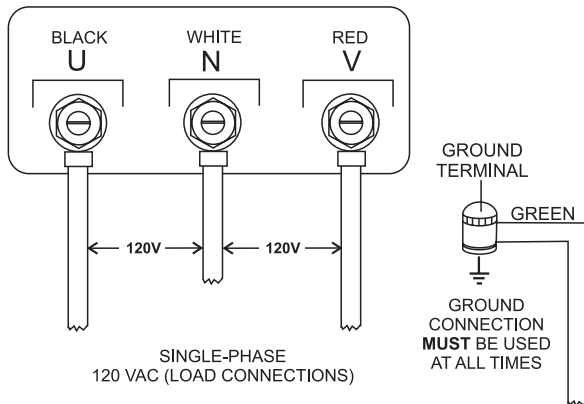

Figure 12. UNV Output Terminal Lugs Single-Phase 120-Volt Connections

2. Turn the **voltage regulator** (Figure 13) clockwise to increase voltage output, turn counterclockwise to decrease voltage output. Use the voltage regulator whenever fine tuning of the output voltage is required.

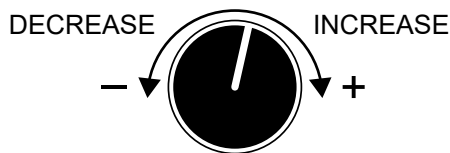

Figure 13. Voltage Regulator

3. Monitor the **voltmeter** (Figure 14) and observe as the output voltage either increases or decreases.

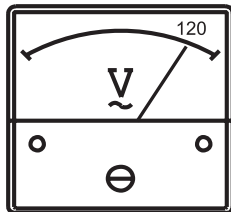

Figure 14. AC Voltmeter

Ammeter

The **ammeter** (Figure 15) indicates how much current (amps) is being supplied to the load from the output terminal lugs or receptacles.

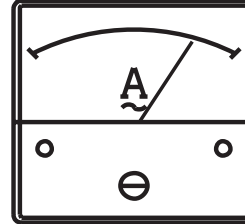

Figure 15. Ammeter (Load)

NOTICE

The ammeter will only show a reading when the output terminal lugs or auxiliary receptacles are connected to a load.

Single-Phase 240-Volt UNV Output Terminal Voltage

1. Connect the load wires to the output terminal lugs as shown in Figure 16.

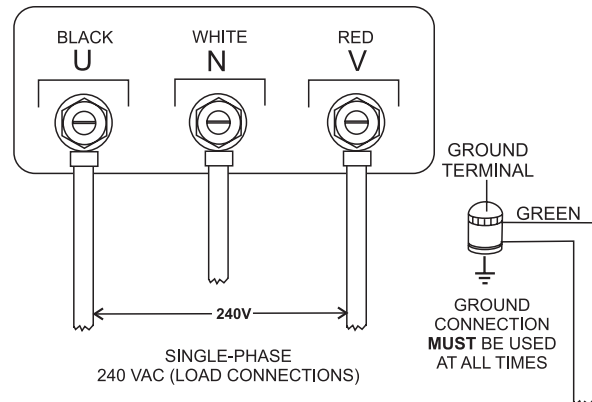

Figure 16. Output Terminal Lugs Single-Phase 240-Volt Connections

2. Turn the **voltage regulator** (Figure 13) clockwise to increase voltage output, turn counterclockwise to decrease voltage output.

NOTICE

ALWAYS make sure that the connections to the UVWO terminals are **secure** and **tight**. The possibility exists of arcing that could cause a fire. Torque tie bolts to 65.0 lbf·in (7.4 N·m).

ENGINE OIL CHECK

Fill the engine crankcase with lubricating oil through the filler hole, but **DO NOT** overfill. Make sure the generator is level and verify that the oil level is maintained between the two notches (Figure 17) on the dipstick. See Table 8 for proper selection of engine oil.

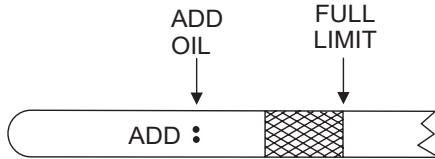

Figure 17. Engine Oil Dipstick

When checking the engine oil, be sure to check if the oil is clean. If the oil is not clean, drain the oil by removing the oil drain plug, and refill with the specified amount of oil as outlined in the Kubota engine owner's manual. Oil should be warm before draining.

Chevron Delo engine oil is the recommended engine oil for this generator. When replacing engine oil, please refill using Delo 400 LE SAE 15W-40 (API CJ-4) engine oil.

Table 8. Recommended Motor Oil		OIL: SAE	
°F	°C	Oil Grade	Oil Grade
122	50	10W/40	10W/40
104	40	10W/40	30
86	30	10W/40	30
68	20	10W/40	30
50	10	10W/40	30
32	0	10W/40	30
-14	-10	ARCTIC OIL	5W/30
-4	-20	ARCTIC OIL	5W/30
-22	-30	ARCTIC OIL	5W/30
-40	-40	ARCTIC OIL	5W/30
			15W/30
			10W
			20W/40

FUEL CHECK

! DANGER

Fuel spillage on a **hot** engine can cause a **fire** or **explosion**. If fuel spillage occurs, wipe up the spilled fuel completely to prevent fire hazards. **NEVER** smoke around or near the generator. **ALWAYS** shut down the engine prior to cleaning up any spilled fuel.

Refilling The Fuel System

NOTICE

DO NOT refuel while the engine is running.

! CAUTION

ONLY properly trained personnel who have read and understand this section should refill the fuel tank system.

This generator is equipped with an **internal fuel tank** (Figure 18) located inside the enclosure and may also be equipped with a trailer mounted fuel tank. **ALWAYS** fill the fuel tank with clean, fresh #2 diesel fuel. **DO NOT** fill the fuel tank beyond its capacity.

Pay attention to the fuel tank capacity when replenishing fuel. The fuel tank cap must be closed tightly after filling. Handle fuel in a safety container. If the container does not have a spout, use a funnel. Wipe up any spilled fuel immediately.

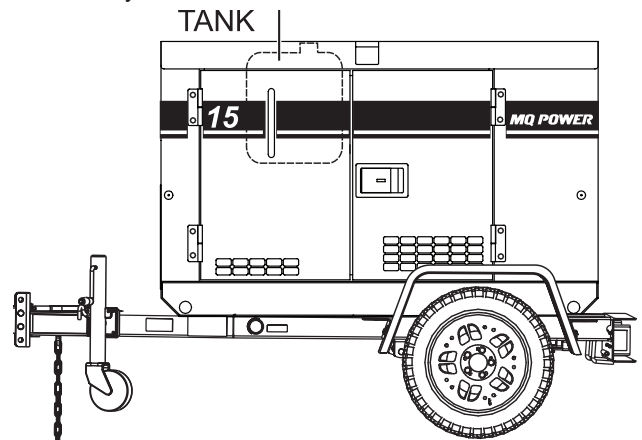

Figure 18. Fuel Tank

INSPECTION/SETUP

Refueling Procedure

WARNING



Diesel fuel and its vapors are dangerous to your health and the surrounding environment. Avoid inhalation of fumes and contact with skin.

1. **Level Tanks** — Make sure fuel cells are level with the ground. Failure to do so will cause fuel to spill from the tank before reaching full capacity (Figure 19).

CAUTION

ALWAYS place the trailer on firm, level ground before refueling to prevent spilling and to maximize the amount of fuel that can be pumped into the tank.

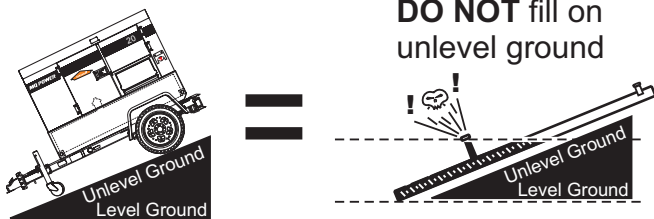

DO NOT fill on unlevel ground

Figure 19. Only Fill On Level Ground

NOTICE

ONLY use #2 diesel fuel when refueling.

2. Remove fuel cap (located on top of generator) and fill fuel tank as shown in Figure 20.

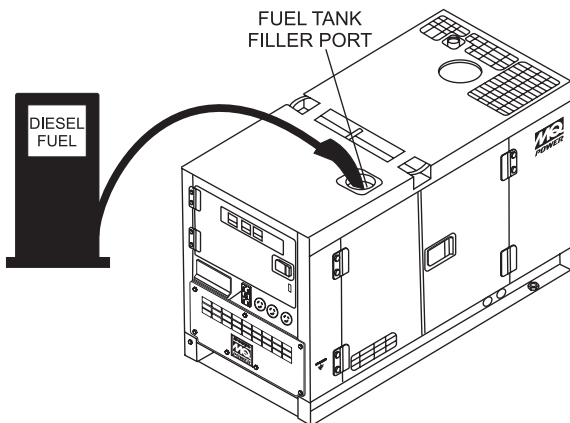

Figure 20. Fueling The Generator

3. **NEVER overfill the fuel tank** — It is important to read the **fuel gauge** (Figure 21) when filling the fuel tank. **DO NOT** wait for fuel to rise in the filler neck.

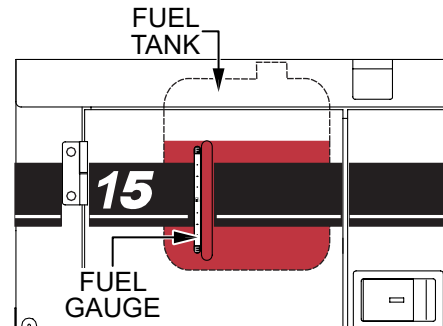

Figure 21. Full Fuel Tank

CAUTION

DO NOT OVERFILL the fuel system. Leave room for fuel expansion. Fuel expands when heated (Figure 22).

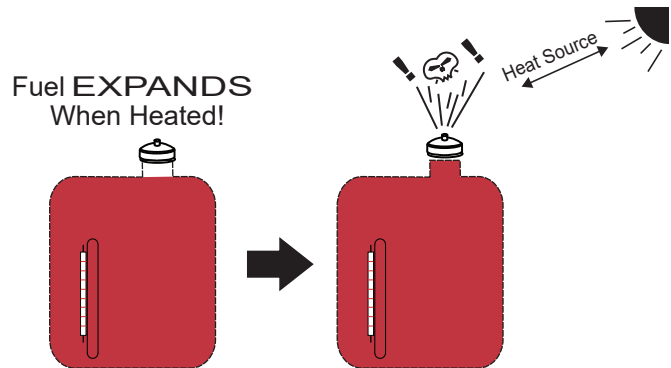

Figure 22. Fuel Expansion

COOLANT (ANTIFREEZE/SUMMER COOLANT/WATER)

Kubota recommends antifreeze/summer coolant for use in their engines, which can be purchased in concentrate (and mixed with 50% demineralized water) or pre-diluted. See the Kubota engine owner's manual for further details.

WARNING



When adding coolant/antifreeze mix to the radiator, **DO NOT** remove the radiator cap until the unit has completely cooled. The possibility of **hot!** coolant exists which can cause severe burns.

Day-to-day addition of coolant is done from the reserve tank. When adding coolant to the radiator, **DO NOT** remove the radiator cap until the unit has completely cooled. See Table 9 for engine, radiator, and reserve tank coolant capacities.

NOTICE

Normally, only the coolant level in the reserve tank needs to be checked. However, the radiator cap should be opened once a week to verify that coolant is visible (full) inside the radiator.

Table 9. Coolant Capacity

Engine and Radiator	1.85 gal (7.0 liters)
Reserve Tank	See markings

Verify that the coolant level in the coolant reserve tank is between the **FULL** and **LOW** markings as shown in Figure 23.

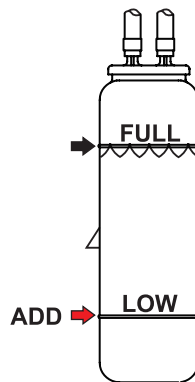

Figure 23. Coolant Reserve Tank

Operation In Freezing Weather

When operating in freezing weather, be certain the proper amount of antifreeze (Table 10) has been added.

Table 10. Antifreeze Operating Temperatures

Vol. % Antifreeze	Freezing Point	
	°C	°F
50	-37	-34

NOTICE

When the antifreeze is mixed with water, the antifreeze mixing ratio **must be** less than 50%.

Cleaning The Radiator

The engine may overheat if the radiator fins become overloaded with dust or debris. Periodically clean the radiator fins with compressed air. Cleaning inside the machine is dangerous, so clean only with the engine turned off and the **negative** battery terminal disconnected.

ENGINE AIR CLEANER

Periodic cleaning/replacement of the air cleaner is necessary. Inspect the air cleaner in accordance with the **Maintenance** section of this manual or the Kubota engine owner's manual.

FAN BELT TENSION

A slack fan belt may contribute to overheating, or to insufficient charging of the battery. Inspect the fan belt for damage and wear and adjust it in accordance with the Kubota engine owner's manual.

The fan belt tension is proper if the fan belt bends 0.28–0.35 in. (10 to 15 mm) when depressed with the thumb as shown in Figure 24.

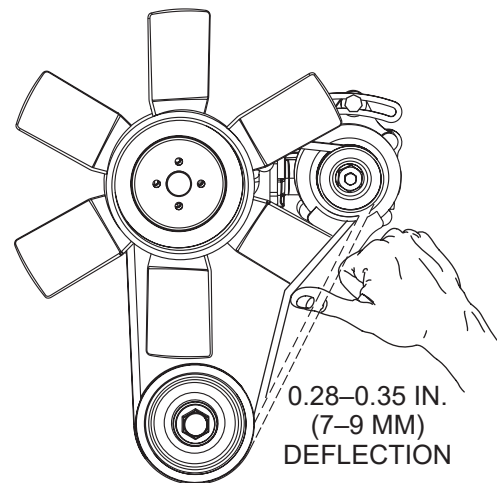

Figure 24. Fan Belt Tension

CAUTION



NEVER place hands near the belts or fan while the generator set is running.

BATTERY

This unit is of negative ground. **DO NOT** connect in reverse. Always maintain battery fluid level between the specified marks. Battery life will be shortened if the fluid level is not properly maintained. Add only distilled water when replenishment is necessary.

DO NOT overfill. Check to see whether the battery cables are loose. Poor contact may result in poor starting or malfunctions. **ALWAYS** keep the terminals firmly tightened. Coat the terminals with an approved battery terminal treatment compound. Replace the battery with only recommended type battery. The battery type used in this generator is BCI Group 24.

The battery is sufficiently charged if the specific gravity of the battery fluid is 1.28 (at 68° F). If the specific gravity should fall to 1.245 or lower, it indicates that the battery is dead and needs to be recharged or replaced.

Before charging the battery with an external electrical source, be sure to disconnect the battery cables.

Battery Cable Installation

ALWAYS be sure the battery cables (Figure 25) are properly connected to the battery terminals as shown below. The red cable is connected to the positive terminal of the battery, and the black cable is connected to the negative terminal of the battery.

CAUTION

ALWAYS disconnect the negative terminal **FIRST** and reconnect negative terminal **LAST**.

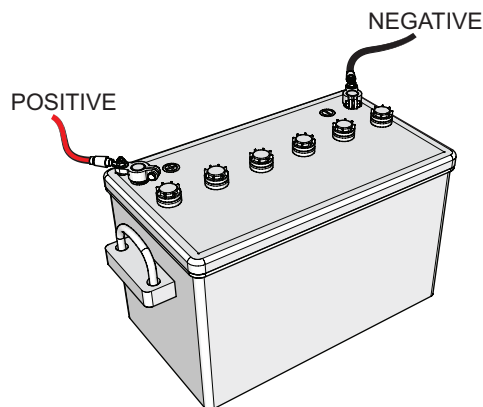

Figure 25. Battery Connections

When connecting battery:

1. **NEVER** connect the battery cables to the battery terminals while the ignition switch is in the **RUN**, **PREHEAT**, or **START** position. **ALWAYS** make sure that this switch is in the **STOP** position when connecting the battery.
2. Place a small amount of battery terminal treatment compound around both battery terminals. This will ensure a good connection and will help prevent corrosion around the battery terminals.

NOTICE

If the battery cables are connected incorrectly, electrical damage to the generator will occur. Pay close attention to the polarity of the battery when connecting the battery.

NOTICE

Inadequate battery connections may cause poor starting of the generator or other malfunctions.

ALTERNATOR

The polarity of the alternator is negative grounding type. When an inverted circuit connection takes place, the circuit will be in short circuit instantaneously resulting in alternator failure.

DO NOT put water directly on the alternator. Entry of water into the alternator can cause corrosion and damage the alternator.

WIRING

Inspect the entire generator for bad or worn electrical wiring or connections. If any wiring or connections are exposed (insulation missing) replace wiring immediately.

PIPING AND HOSE CONNECTIONS

Inspect all piping, oil hose, and fuel hose connections for wear and tightness. Tighten all hose clamps and check hoses for leaks.

If any fuel or oil hose lines are defective, replace them immediately.

GENERATOR START-UP PROCEDURE

BEFORE STARTING

CAUTION

The engine's exhaust contains harmful emissions. **ALWAYS** have adequate ventilation when operating. Direct exhaust away from nearby personnel.

WARNING

NEVER manually start the engine with the **main, GFCI or auxiliary** circuit breakers in the **ON** (closed) position.

1. Place the **main, auxiliary, and GFCI** circuit breakers (Figure 26) in the **OFF** position prior to starting the engine.

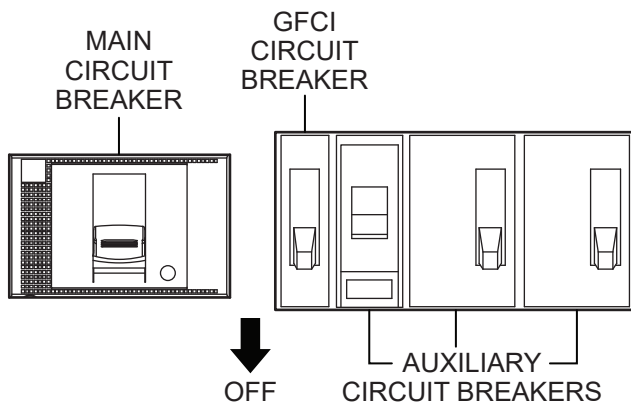

Figure 26. Main, Auxiliary, And GFCI Circuit Breakers (OFF)

2. Connect the load to the **receptacles** or the **output terminal lugs** as shown in Figure 10. These load connection points can be found on the output terminal panel.

NOTICE

ALWAYS make sure that the connections to the UVWO terminals are **secure** and **tight**. The possibility exists of arcing that could cause a fire. Torque tie bolts to 65.0 lbf·in (7.4 N·m).

3. Close all engine enclosure doors (Figure 27).

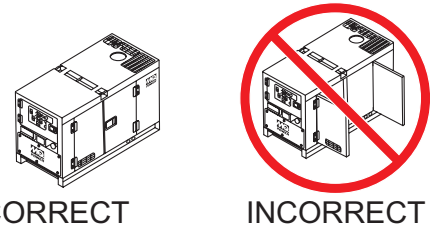

Figure 27. Engine Enclosure Doors

STARTING

1. Place the **engine speed switch** in the **LOW** position (Figure 28).



Figure 28. Engine Speed Switch (Low)

2. Insert the ignition key into the ignition switch. Turn the key clockwise to the **PREHEAT** position (Figure 29A) and observe the Preheat lamp is **ON**.

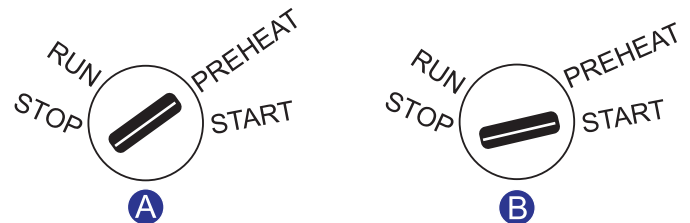

Figure 29. Ignition/Starter Switch

3. When the Preheat lamp has turned **OFF**, turn the ignition key clockwise to the **START** position (Figure 29B). When the engine starts, release the key so that it can automatically return to the **RUN** position. If the engine fails to start within 10 seconds, wait 30 seconds and repeat this step.
4. Once the engine starts, let the engine run at low speed for 1–2 minutes. Listen for any abnormal noises. If any abnormalities exist, shut down the engine and correct the problem.

NOTICE

In cold weather conditions, warm up the engine for 5–7 minutes before placing the generator into operation.

GENERATOR START-UP PROCEDURE

5. After the warmup process has completed, place the **Engine Speed switch** in the **HIGH** position. The generator is now ready for operation.



Figure 30. Engine Speed Switch (High)

6. The **frequency meter** (Figure 31) will display the 60-cycle output frequency in **HERTZ**.

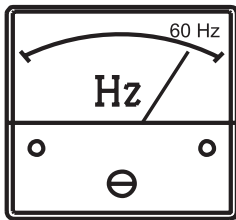

Figure 31. Frequency Meter

7. The **AC voltmeter** (Figure 32) will display the generator's output in **VOLTS**.

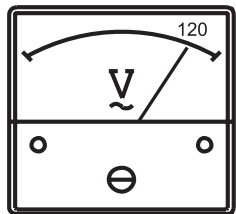

Figure 32. Voltmeter

8. If the voltage is not within the specified tolerance, use the **voltage regulator** (Figure 33) to increase or decrease the desired voltage.



Figure 33. Voltage Regulator

9. The **ammeter** (Figure 34) will indicate **zero amps** with no load applied. When a load is applied, the ammeter will indicate the amount of current that the load is drawing from the generator.

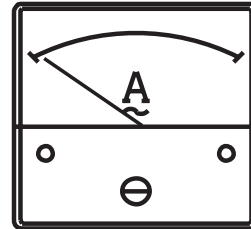

Figure 34. Ammeter (No Load)

10. Place the **main, auxiliary, and GFCI** circuit breakers in the **ON** position (Figure 35).

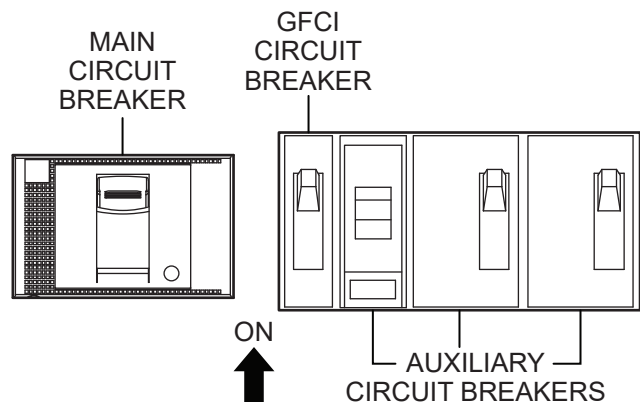

Figure 35. Main, Aux. and GFCI Circuit Breakers (ON)

11. Observe the generator's ammeter (Figure 36) and verify it reads the anticipated amount of current with respect to the load. The ammeter will only display a current reading if a load is in use.

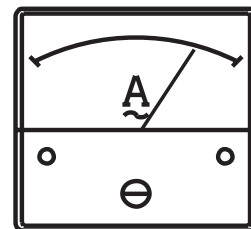

Figure 36. Ammeter (Load)

12. The generator will run until manually stopped or an abnormal condition occurs.

GENERATOR SHUTDOWN PROCEDURE

NORMAL SHUTDOWN PROCEDURE

WARNING

NEVER stop the engine suddenly except in an emergency.

To shut down the generator, use the following procedure:

1. Place the load's ON/OFF switch in the **OFF** position.
2. Place the **main, auxiliary, and GFCI circuit breakers** in the **OFF** position (Figure 37).

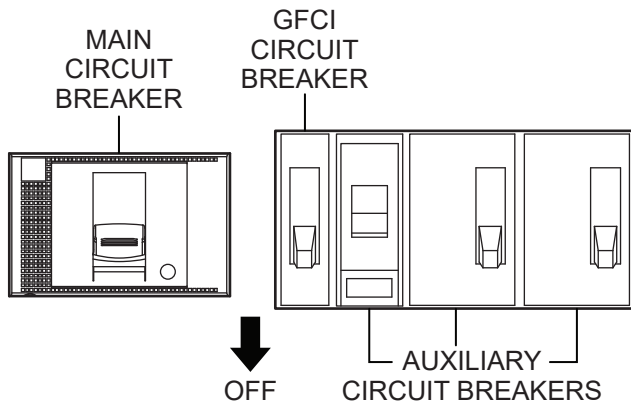

Figure 37. Main, Auxiliary, And GFCI Circuit Breakers (OFF)

3. Place the **engine speed switch** in the **LOW** position (Figure 38) and let the engine cool for 3–5 minutes with no load applied.



Figure 38. Engine Speed Switch (Low)

4. Turn the ignition key counterclockwise to the **STOP** position (Figure 39). When the engine has stopped, remove the key. Place the key in a safe place where it will not be lost.

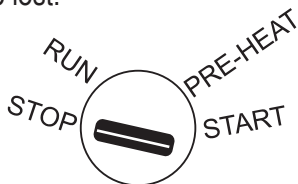

Figure 39. Ignition/Starter Switch (Stop)

5. Remove all loads from the generator.
6. Inspect entire generator for any damage or loosening of components that may have occurred during operation.

EMERGENCY SHUTDOWN PROCEDURE

1. Place the **main, auxiliary, and GFCI circuit breakers** in the **OFF** position (Figure 37).
2. Turn the ignition key counterclockwise to the **STOP** position (Figure 39).

Emergency Stop Switch (Option)

NOTICE

If equipped, the **Emergency Stop switch** should **only** be used to stop the engine in case of an emergency or to lock out operation during service. The Emergency Stop switch should **NEVER** be used for routine stopping of the engine.

1. If equipped (optional), press the **Emergency Stop switch** (Figure 40) to stop the engine in the event of an emergency.

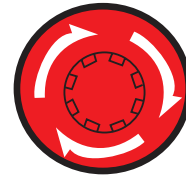

Figure 40. Emergency Stop Switch

2. Place the **main, auxiliary, and GFCI circuit breakers** in the **OFF** position (Figure 37).
3. The emergency stop switch is a push-locked type switch. The switch contact can only be released by rotating the button in the clockwise direction. The engine can not be restarted until the contact is released (closed).

GENERATOR SHUTDOWN PROCEDURE

AUTOMATIC SHUTDOWN SYSTEM

This generator is equipped with engine protection devices that will automatically shut down the engine and provide a warning to the operator when a fault occurs. The alarm lamps on the control panel will illuminate to indicate the reason for the shutdown. Refer to the **Troubleshooting (Faults)** section of this manual for more information. Table 12 contains a complete list of engine protection devices and fault codes. If necessary, contact MQ Power for additional technical support.

NOTICE

Before inspecting the generator after an automatic shutdown, make sure the ignition/start switch is in the **STOP** position, and place all circuit breakers in the **OFF** position. Allow adequate time for cooling before troubleshooting. When all faults have been cleared, restart the engine according to the **Generator Start-Up Procedure** section of this manual.

NOTICE

Although the unit is equipped with engine protection devices, regularly scheduled preventive maintenance is strongly advised. Refer to Table 11.

MAINTENANCE

Table 11. Inspection/Maintenance		10 Hours/ Daily	100 Hours	200 Hours	250 Hours	400 Hours	500 Hours	1,000 Hours
Engine	Check Engine Fluid Levels	X						
	Check Fuel Level	X						
	Check Battery Acid Level	X						
	Check Fan Belt Condition	X						
	Check for Leaks	X						
	Check for Loosening of Parts	X						
	Clean Air Filter		X					
	Replace Engine Oil and Filter * ¹			X				
	Drain Fuel Tank			X				
	Clean Unit, Inside and Outside			X				
	Check Emission Carbon				X			
	Replace Fuel Filter					X		
	Replace Air Filter Element						X	
	Clean Radiator and Check Coolant Level						X	
	Check All Hoses and Clamps						X	
Clean Inside of Fuel Tank							X	
Generator	Measure Insulation Resistance Over 3M Ohms					X		
	Check Rotor Rear Support Bearing						X	
Complete Machine	Inspect Acoustic Insulation						X	

*¹ During initial operation of a new engine, change oil and filter at 50 hours first time ONLY. Service interval depends on type of oil.

* Accumulation of carbon (soot, unburned fuel) in the exhaust pipe line and muffler could cause not only system derates but also could lead to a fire incident. To destroy the soot and unburned fuel, run the unit at rated power for some period of time until the exhaust gas becomes mostly colorless every 250 hours of operation time. More carbon will be generated when the unit operates at less then 30% of rated power. In this case, perform the above procedures more frequently.

* Applying a large load suddenly to the unit when carbon deposits have accumulated in the exhaust system could produce fire/sparks which could lead to abnormal combustion. Therefore it is recommended to **apply the load gradually** and observe the exhaust gas color during the process.

* Fire or sparks may be emitted from the exhaust gas outlet during operation under load. Make sure the area surrounding the unit is free from any **flammable** material.

GENERAL INSPECTION

Prior to each use, the generator should be cleaned and inspected for deficiencies. Check for loose, missing or damaged nuts, bolts or other fasteners. Also check for fuel, oil, and coolant leaks. Use Table 11 as a general maintenance guideline. For more detailed engine maintenance instructions, refer to the engine owner's manual.

ENGINE AIR CLEANER

The air cleaner (Figure 41) included with this Kubota diesel engine is equipped with a replaceable, high-density, paper air filter element. Check the air cleaner daily or before starting the engine. Replace the air cleaner as needed.

NOTICE

If the engine is operating in very dusty or dry grass conditions, a clogged air cleaner will result. This can lead to a loss of power, excessive carbon buildup in the combustion chamber, and high fuel consumption. Change the air cleaner more frequently if these conditions exist.

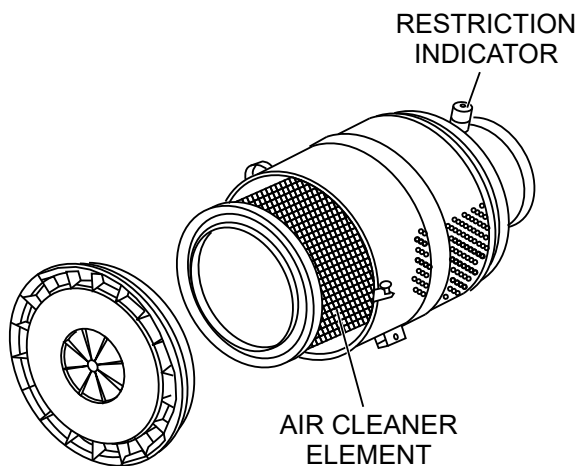

Figure 41. Engine Air Cleaner

Every 100 hours: Remove the air cleaner element and clean it with a light spray of compressed air.

CAUTION



Wear protective equipment such as approved safety glasses or face shields and dust masks or respirators when cleaning air filters with compressed air.

NOTICE

DO NOT run the engine with the air cleaner removed or without an element.

Air Cleaner Restriction Indicator

The air cleaner is equipped with a restriction indicator (Figure 41). As the air cleaner element becomes clogged, air intake restriction increases and the indicator signal shows RED, indicating that the element needs to be replaced. After replacing the air cleaner element, press the restriction indicator button to reset the indicator.

NOTICE

DO NOT overservice the air cleaner element. Overservicing may cause dirt to enter the engine causing premature wear. Use the dust indicator as a guide for when to service. The air cleaner element should not be changed until the indicator displays RED.

ENGINE FUEL FILTER

Inspect all fuel lines every 50 hours of operation. Clean the fuel filter every 100 hours of operation or once a month to remove dust or water.

Cleaning The Fuel Filter

1. Place the **fuel cock lever** (Figure 42) in the **OFF** (closed) position.

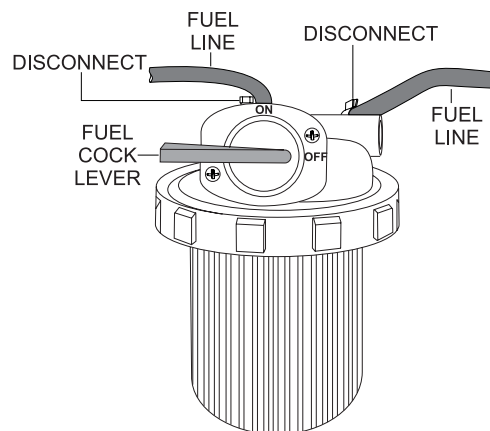

Figure 42. Fuel Filter Disconnection

2. Disconnect the **fuel lines** (Figure 42) from the fuel filter.

3. Unscrew the **filter bowl** from the **filter head** (Figure 43).

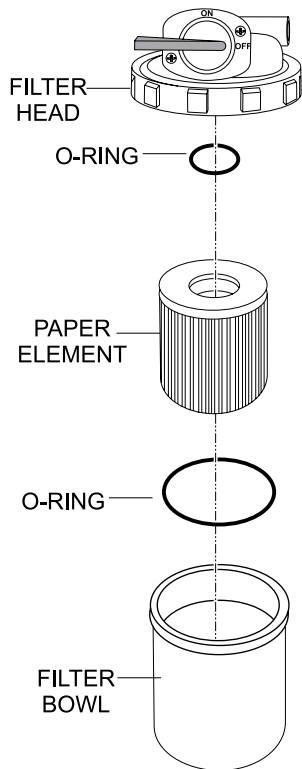

Figure 43. Fuel Filter Disassembly

4. Wipe the inside of the fuel filter bowl with a clean cloth to remove any foreign matter or debris that may have accumulated. Rinse with diesel fuel.
5. Remove the **paper element** (Figure 43) from the fuel filter and rinse with diesel fuel.
6. Reinstall the paper element and filter bowl onto the filter head. Tighten the retaining ring by hand.
7. Reconnect the fuel lines to the fuel filter.
8. Air bleed the fuel system. Refer to **Air Bleeding the Fuel System** in the Kubota engine owner's manual.

Fuel Filter Cartridge Replacment

- Replace the fuel filter cartridge every 400 hours of operation.
- Apply fuel oil thinly over the gasket and tighten the cartridge into position by hand only.
- Air bleed the fuel system. Refer to **Air Bleeding the Fuel System** in the Kubota engine owner's manual.

FUEL TANK

Removing Water From The Fuel Tank

After prolonged use, water and other impurities accumulate in the bottom of the fuel tank. Occasionally inspect the fuel tank for water contamination and drain the contents if necessary.

NOTICE

During cold weather, the more empty volume inside the tank, the easier it is for water to condense. This can be reduced by keeping the tank full with diesel fuel.

Cleaning Inside The Fuel Tank

1. Drain the fuel from inside the fuel tank completely.
2. Using a spray washer (Figure 44) wash out any deposits or debris that have accumulated inside the fuel tank.



Figure 44. Cleaning The Fuel Tank

Fuel Tank Inspection

In addition to cleaning the fuel tank, the following components should be inspected for wear:

- **Rubber Suspension** — Look for signs of wear or deformity due to contact with oil. Replace the rubber suspension if necessary.
- **Fuel Hoses** — Inspect nylon and rubber hoses for signs of wear, deterioration, or hardening.
- **Fuel Tank Lining** — Inspect the fuel tank lining for signs of excessive amounts of oil or other foreign matter.

DRAINING THE ENGINE OIL

NOTICE

ALWAYS drain the engine oil while the oil is **warm**.

1. Run the engine for a few minutes to allow the engine oil to warm up, then turn the engine **OFF**.
2. Remove the oil dipstick from its holder.
3. Remove the **oil drain bolt** and **O-ring** (Figure 45), then allow the oil to drain into a suitable container.
4. After the engine oil has completely drained, reinstall the oil drain bolt and O-ring and tighten securely.

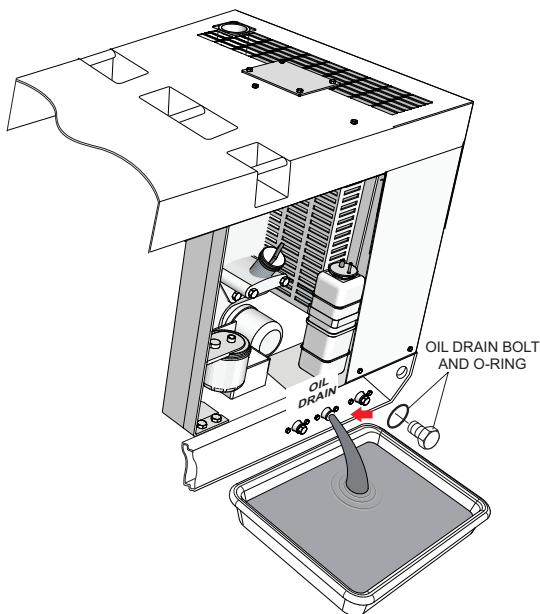

Figure 45. Draining The Engine Oil

ENGINE OIL FILTER REPLACEMENT

1. Using an **oil filter wrench**, remove the engine **oil filter** (Figure 46).

NOTICE

Use an oil filter wrench **only** to remove the old oil filter. **DO NOT** use the oil filter wrench to install the new filter.

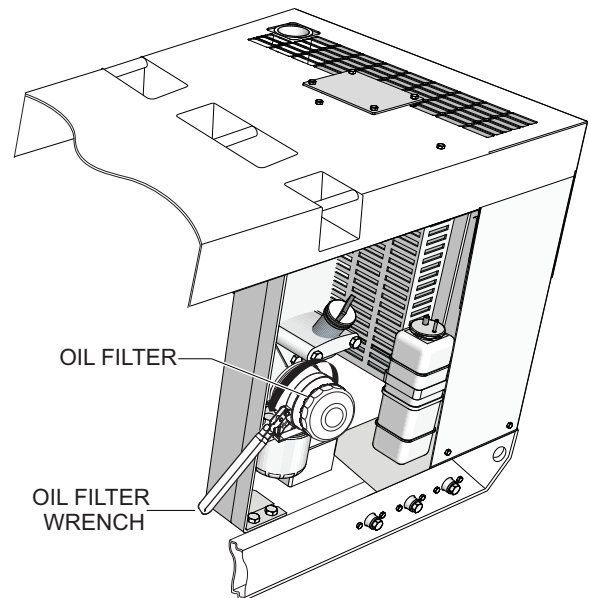

Figure 46. Engine Oil Filter Removal

2. Coat the **rubber seal** (gasket) surface of the new oil filter with clean **15W-40 engine oil** (Figure 47).

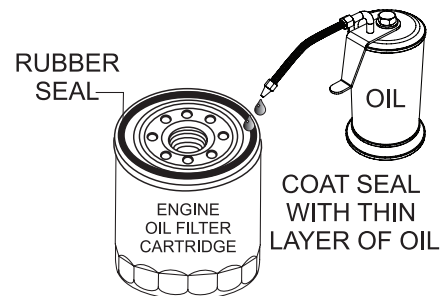

Figure 47. Oil Filter Gasket

3. Install the new oil filter cartridge and tighten as much as possible **by hand only**. **DO NOT** use the oil filter wrench to tighten the oil filter.
4. Fill the engine crankcase with high-quality detergent oil as shown in . Fill to the upper limit of the dipstick. **DO NOT** overfill. Refer to Table 2 for engine oil capacity.

5. Run the engine for several minutes. Watch for oil leakage. Shut the engine down and allow it to sit for several minutes. Top off the oil to the upper limit on the dipstick.

DRAINING THE ENGINE COOLANT

WARNING

DO NOT remove the pressure cap from the radiator when the engine is hot! Wait until the coolant temperature is below 120°F (50°C) before removing the pressure cap. Heated coolant spray or steam can cause severe scalding and personal injury.



1. Remove the **radiator pressure cap** (Figure 48) only when the coolant temperature is below 120°F (50°C).

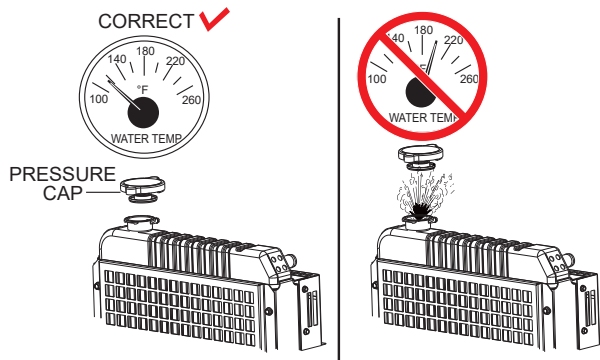

Figure 48. Radiator Pressure Cap Removal

2. Remove the **coolant drain bolt and O-ring** (Figure 49), then allow the coolant to drain into a suitable container.

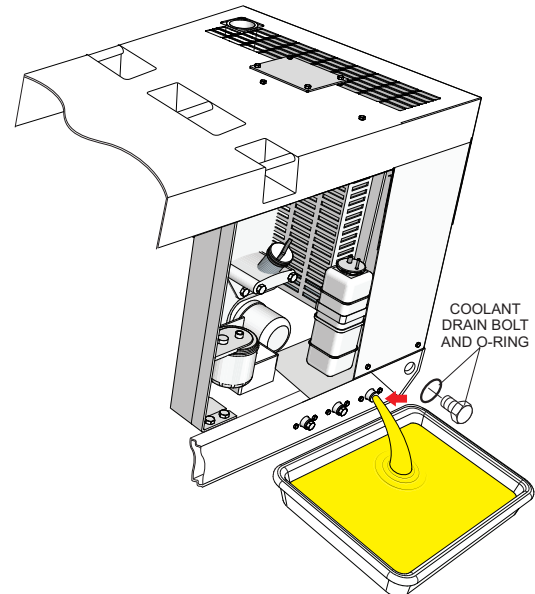

Figure 49. Draining The Engine Coolant

3. After the coolant has completely drained, reinstall the coolant drain bolt and O-ring.
4. Reinstall the radiator pressure cap and tighten securely.

FLUSHING OUT THE RADIATOR AND REPLACING THE COOLANT

WARNING



DO NOT remove the pressure cap from the radiator when the engine is hot! Wait until the coolant temperature is below 120°F (50°C) before removing the pressure cap. Heated coolant spray or steam can cause severe scalding and personal injury.

1. Remove the **radiator pressure cap** (Figure 48) only when the coolant temperature is below 120°F (50°C).
2. Remove the **coolant drain bolt** and **O-ring** (Figure 49), then allow the coolant to drain into a suitable container.
3. If equipped, remove the overflow tank. Drain and clean the overflow tank.
4. Replace the overflow tank if necessary.
5. Check all hoses for softening and kinks. Check all clamps for signs of leakage.
6. Flush the radiator by running clean tap water through the radiator until all signs of rust and dirt are removed. **DO NOT** clean the radiator core with any objects, such as a screwdriver.
7. Replace with coolant as recommended by the engine manufacturer. Refer to Table 2 for engine coolant capacity.
8. Reinstall the coolant drain bolt and O-ring and tighten securely.

RADIATOR CLEANING

The **radiator** (Figure 50) should be spray-cleaned with a high-pressure washer when excessive amounts of dirt and debris have accumulated on the cooling fins or tube. When using a high-pressure washer, stand at least 5 feet (1.5 meters) away from the radiator to prevent damage to the fins and tube.

NOTICE

It may be necessary to remove additional generator components to access the radiator for cleaning.



Figure 50. Radiator Cleaning

DRIVE BELT

Drive Belt Tension

A slack drive belt may contribute to overheating or insufficient charging of the battery. Adjust the drive belt in accordance with the Isuzu engine owner's manual.

Drive Belt Inspection

1. Inspect the **drive belt** (Figure 51) for damage and wear. Horizontal cracks (across the belt) are acceptable. Vertical cracks (direction of belt ribs) that intersect with horizontal cracks are not acceptable.

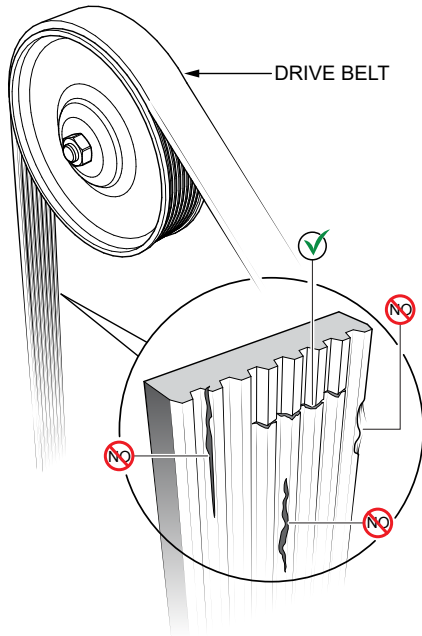

Figure 51. Drive Belt Inspection

2. Examine the belt and determine if it is **oil soaked** or **glazed** (a hard shiny appearance on the sides of the belt). Either of these two conditions can cause the belt to run hot, which can weaken it and increase the danger of it breaking.
3. If the drive belt exhibits any of the above wear conditions, replace it immediately.

TESTING THE GFCI RECEPTACLE

NOTICE

The GFCI receptacle is designed to interrupt power when a ground fault exists to prevent injuries and shock hazards. **DO NOT** use the GFCI receptacle if the test below fails. Consult a qualified electrician for repair or replacement of the GFCI receptacle. Test the GFCI receptacle **at least once a month**.

1. Start the generator as outlined in the start-up procedure in this manual.
2. Place the **GFCI circuit breaker** (Figure 52) in the **ON** position.

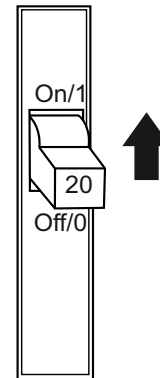

Figure 52. GFCI Circuit Breaker

3. Verify that the **status LED** on the **GFCI receptacle** (Figure 53) is **ON (GREEN)**.

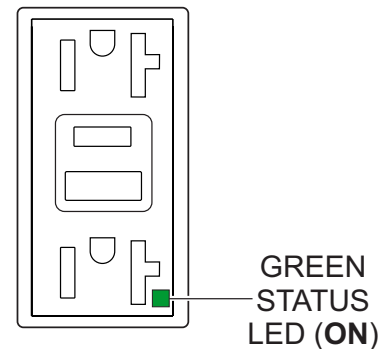

Figure 53. GFCI Receptacle (ON)

4. Press the **TEST button** (Figure 54) on the GFCI receptacle and verify that the status LED turns **OFF**.

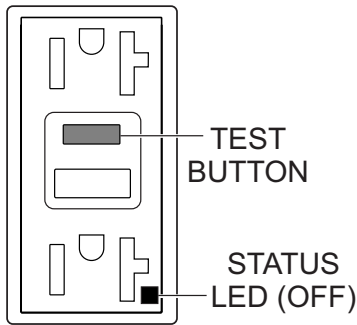

Figure 54. GFCI Receptacle (OFF)

5. Press the **RESET button** (Figure 55) to restore power to the GFCI receptacle and verify that the status LED is **ON (GREEN)**.

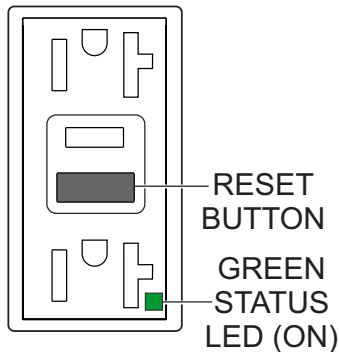

Figure 55. GFCI Receptacle (ON/Restore)

6. If the status LED (Figure 56) is **flashing (RED)**, **DO NOT** use the GFCI receptacle. Replace it immediately.

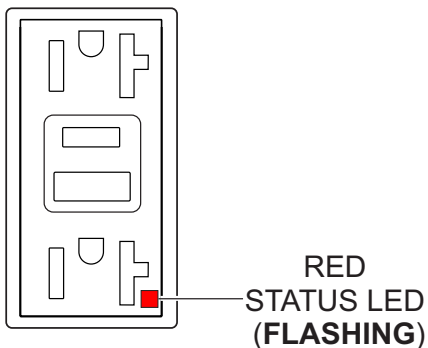

Figure 56. GFCI Receptacle (Red Flashing LED)

GENERATOR STORAGE

For long-term storage of the generator the following is recommended:

- Drain the fuel tank completely. Treat with a fuel stabilizer if necessary.
- Completely drain the oil from the crankcase and refill if necessary with fresh oil.
- Clean the entire generator, internal and external.
- Disconnect the battery.
- Make sure engine coolant is at the proper level.
- Cover the generator and store it in a clean, dry place.
- If generator is mounted on a trailer, jack the trailer up and place it on blocks so the tires do not touch the ground, or block and completely remove the tires.

OPTIONAL ENGINE BLOCK HEATER AND INTERNAL BATTERY CHARGER 120 VAC INPUT RECEPTACLES

This generator can be equipped with an **engine block heater** and an **internal battery charger** as **options**. They are provided with electrical cords to connect to a commercial power source.

The engine block heater and internal battery charger both require 120 VAC for operation. The output receptacle panel of this generator can be optionally equipped with two 120-volt, 20-amp input receptacles to provide commercial power for these optional features.

These receptacles will **ONLY** function when commercial power has been supplied to them (Figure 57). When using extension cords, refer to Table 6 for the correct size and length.

When using the generator in hot climates there is no reason to apply power to the engine block heater. However, if the generator will be used in cold climates it is always a good idea to apply power to the heater at all times.

If the generator will be used daily, the battery should normally not require charging. If the generator will be idle (not used) for long periods of time, apply power to the battery charger receptacle via commercial power using a power cord of adequate size.

NOTICE

If the generator will be idle (not used) for long periods of time, **ALWAYS** keep power supplied to the generator's internal battery charger to ensure adequate starting capability.

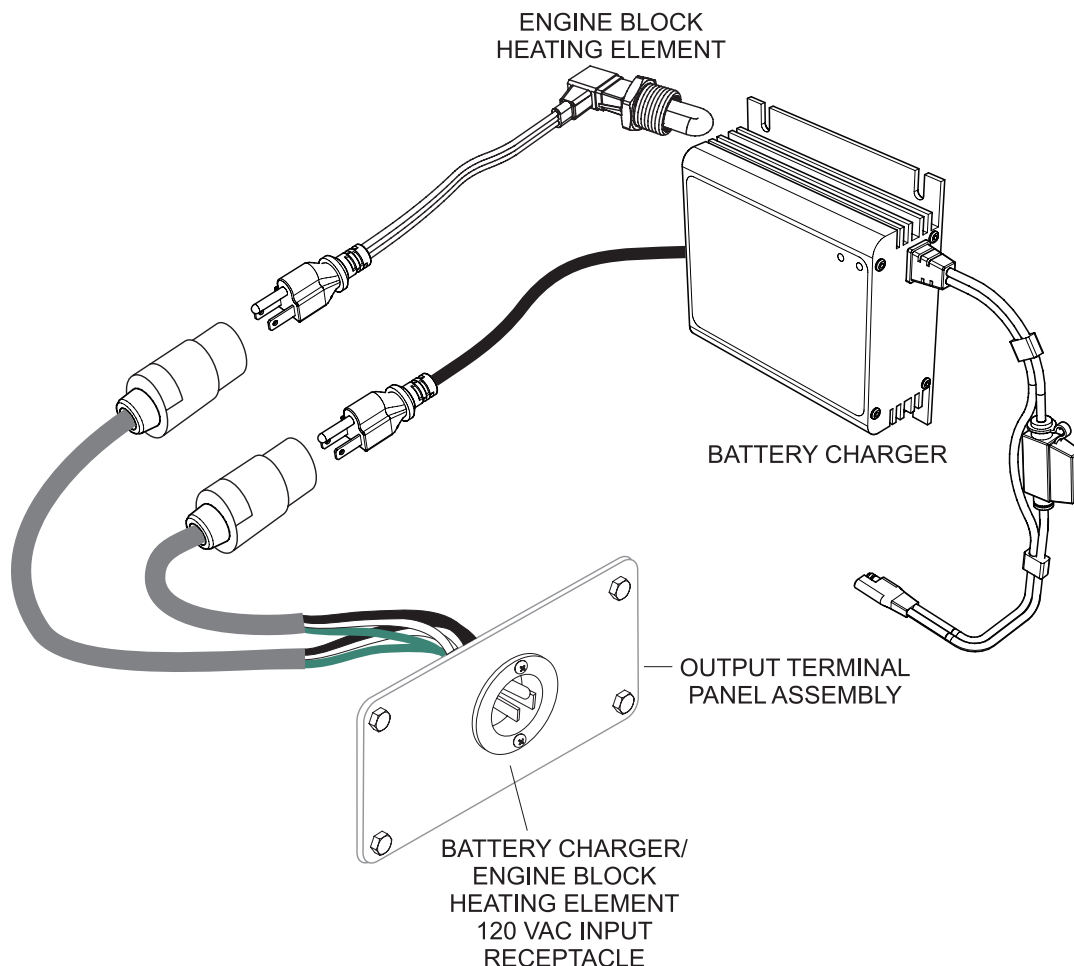

Figure 57. Engine Block Heater And Battery Charger (Options)

TROUBLESHOOTING (DIAGNOSTICS)

ENGINE MALFUNCTION DIAGNOSTIC LAMP CODES

When an engine malfunction is detected, the engine will shut down and a fault code will be indicated as a flashing pattern on the Preheat lamp.

The engine fault code flashing patterns consist of a combination of one or more long flashes and one or more short flashes. Refer to Table 12 for a list of fault code flashing patterns and the associated countermeasures.

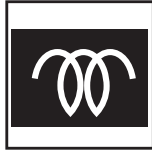

Figure 58. Preheat Lamp

Table 12. Engine Fault Lamp Codes

Symptom	Condition	Flashing Pattern	Solution
Engine Over Speed	$\geq 115\%$ of rated engine speed	1 Long 1 Short	Adjust engine speed.
Low Oil Pressure	Oil pressure switch on, Engine shutdown at 7.1 psi (49 kPa)	1 Long 2 Short	Check engine oil level and switch.
Low Battery Voltage	Insufficient charge	1 Long 3 Short	Inspect or replace engine alternator/voltage regulator.
High Water Temperature	Overheat, Engine shutdown at 239°F (115°C)	1 Long 4 Short	Make sure routine service has been performed, and check the thermo switch. If the problem persists, contact the Service Department for repairs.
Rotation Sensor Fault	Defective sensor, disconnection, or short circuit	2 Long 1 Short	Check wiring, replace sensor.
Solenoid Fault	Disconnection or short circuit	2 Long 2 Short	Check wiring, replace fuel solenoid.
Water Temperature Sensor Fault	Disconnection	2 Long 4 Short	Check wiring or replace sensor.
	Short circuit	2 Long 5 Short	
Charging Generator Terminal Fault	Disconnection	2 Long 6 Short	Check wiring. Check or replace battery and engine alternator.
Over Voltage	$VCC \geq 18 V$	2 Long 7 Short	Check or replace voltage regulator and battery.

TROUBLESHOOTING (GENERATOR)

Practically all breakdowns can be prevented by proper handling and maintenance inspections, but in the event of a breakdown, use Table 13 for diagnosis of the generator. If the problem cannot be remedied, consult our company's business office or service plant.

Table 13. Generator Troubleshooting		
Symptom	Possible Problem	Solution
No Voltage Output	Defective AC voltmeter?	Check output voltage and replace if necessary.
	Loose wiring connection?	Check wiring and repair.
	Defective AVR?	Replace if necessary.
	Defective rotating rectifier?	Check and replace.
Low Voltage Output	Low engine speed?	Check and adjust.
	Loose wiring connection?	Check wiring and repair.
	Defective AVR?	Replace if necessary.
High Voltage Output	Loose wiring connection?	Check wiring and repair.
	Defective AVR?	Replace if necessary.
Circuit Breaker Tripped	Short circuit in load?	Check load and repair.
	Over current?	Confirm load requirement and reduce.
	Defective circuit breaker?	Check and replace.
	Overcurrent relay actuated?	Confirm load requirement and reset.

TROUBLESHOOTING (ENGINE)

Troubleshooting (Engine)		
Symptom	Possible Problem	Solution
Engine will not start or start is delayed, although engine can be turned over.	No fuel reaching injection pump?	Add fuel. Check entire fuel system.
	Defective fuel pump?	Replace fuel pump.
	Fuel filter clogged?	Replace fuel filter and clean tank.
	Faulty fuel supply line?	Replace or repair fuel line.
	Compression too low?	Check piston, cylinder and valves. Adjust or repair per engine repair manual.
	Fuel pump not working correctly?	Repair or replace fuel pump.
	Oil pressure too low?	Check engine oil pressure.
	Low starting temperature limit exceeded?	Comply with cold starting instructions and proper oil viscosity.
	Defective battery?	Charge or replace battery.
	Air or water mixed in fuel system?	Check carefully for loosened fuel line coupling, loose cap nut, etc.
At low temperatures engine will not start.	Engine oil too thick?	Refill engine crankcase with correct type of oil for winter environment.
	Defective battery?	Replace battery.
Engine fires but stops as soon as starter is switched off.	Fuel filter blocked?	Replace fuel filter.
	Fuel supply blocked?	Check the entire fuel system.
	Defective fuel pump?	Replace fuel pump.
Engine stops by itself during normal operation.	Fuel tank empty?	Add fuel.
	Fuel filter blocked?	Replace fuel filter.
	Defective fuel pump?	Replace fuel pump.
	Mechanical oil pressure shutdown sensor stops the engine due to low oil?	Add oil. Replace low oil shutdown sensor if necessary.
Low engine power, output and speed.	Fuel tank empty?	Add fuel.
	Fuel filter clogged?	Replace fuel filter.
	Fuel tank venting is inadequate?	Ensure tank is adequately vented.
	Leaks at pipe unions?	Check threaded pipe unions. Tape and tighten unions as required.
	Speed control lever does not remain in selected position?	See engine manual for corrective action.
	Engine oil level too full?	Correct engine oil level.
	Injection pump wear?	Use No. 2-D diesel fuel only. Check the fuel injection pump element and delivery valve assembly and replace as necessary.

TROUBLESHOOTING (ENGINE)

Troubleshooting (Engine) - continued		
Symptom	Possible Problem	Solution
Low engine power output and low speed, black exhaust smoke.	Air filter blocked?	Clean or replace air filter.
	Incorrect valve clearances?	Adjust valves per engine specification.
	Malfunction at injector?	See engine manual.
Engine overheats.	Too much oil in engine crankcase?	Drain off engine oil down to upper mark on dipstick.
	Entire cooling air system contaminated or blocked?	Clean cooling air system and cooling fin areas.
	Fan belt broken or elongated?	Change belt or adjust belt tension.
	Coolant insufficient?	Replenish coolant.
	Radiator net or radiator fin clogged with dust?	Clean net or fin carefully.
	Fan, radiator, or radiator cap defective?	Replace defective part.
	Thermostat defective?	Check thermostat and replace if necessary.
	Head gasket defective or water leakage?	Replace parts.

GENERATOR WIRING DIAGRAM (M0844300104C)

SYMBOL	DESCRIPTION
V	AC Voltmeter
A	AC Ammeter
F	Frequency meter
CT	Current Transformer, Ammeter
U, N, V	Output Terminal
AVR	Automatic Voltage Regulator
VR	Voltage Regulator
CB1	Circuit Breaker
CB2	Circuit Breaker
CB3	Circuit Breaker (GFCI)
CB4	Circuit Breaker
CB5	Circuit Breaker
R	Resistor
Re	Rectifier
CON1	Receptacle
CON2	Receptacle
CON3	Receptacle
CON4	Receptacle
OC	Over Current Relay
J, K	Terminal Board
⊙ G	Ground Terminal

WIRE SIZE	WIRE COLOR	COLOR CODE
0.75:	0.75mm ²	BLACK R
1:	1mm ²	RED R
2:	2mm ²	BLUE L
3.5:	3.5mm ²	WHITE W
5.5:	5.5mm ²	BROWN Y
14:	14mm ²	GREEN G
		GRAY LG
		YELLOW LB
		LIGHT BLUE LY
		LIGHT GREEN LZ
		ORANGE O
		PINK P

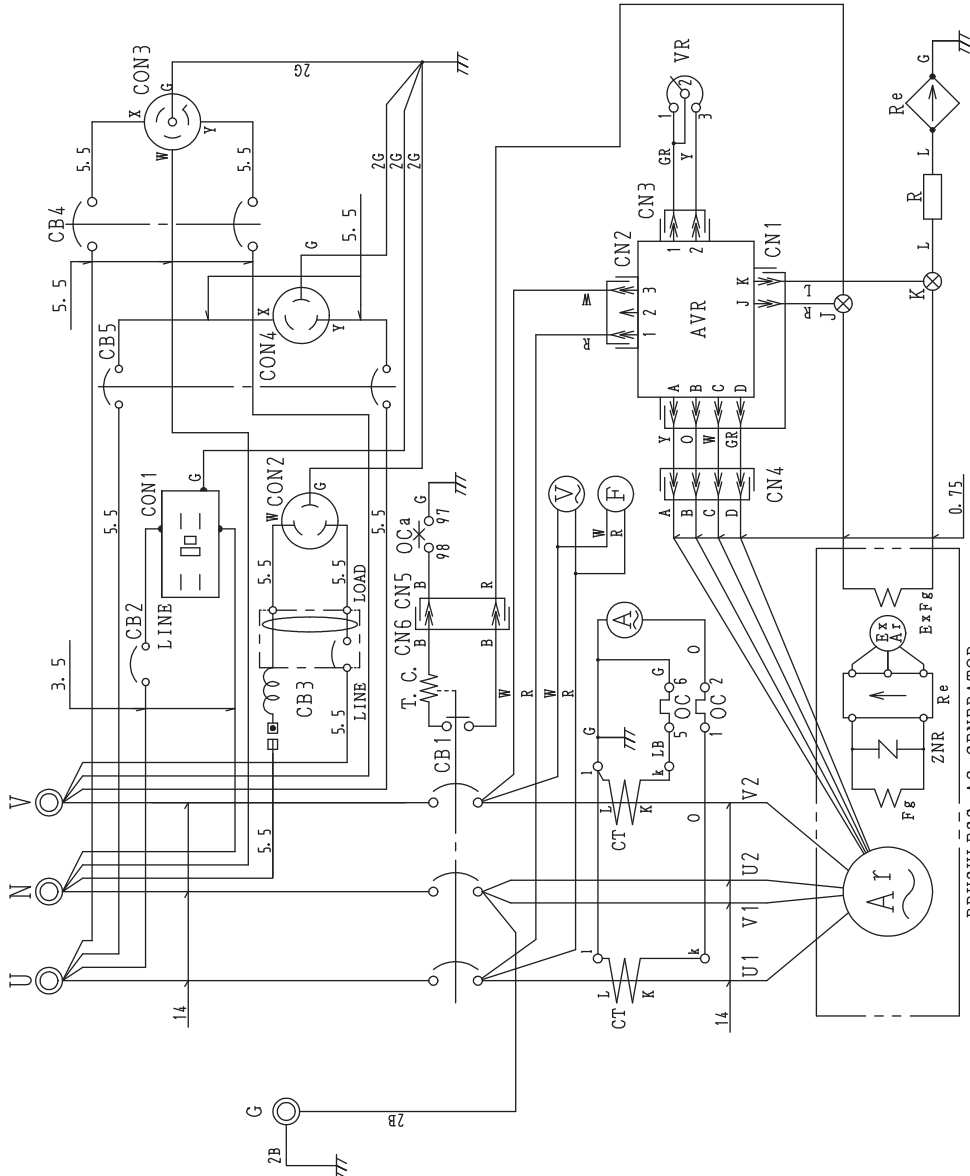

ENGINE WIRING DIAGRAM NO. M0844300104C

ENGINE WIRING DIAGRAM (M081410003)

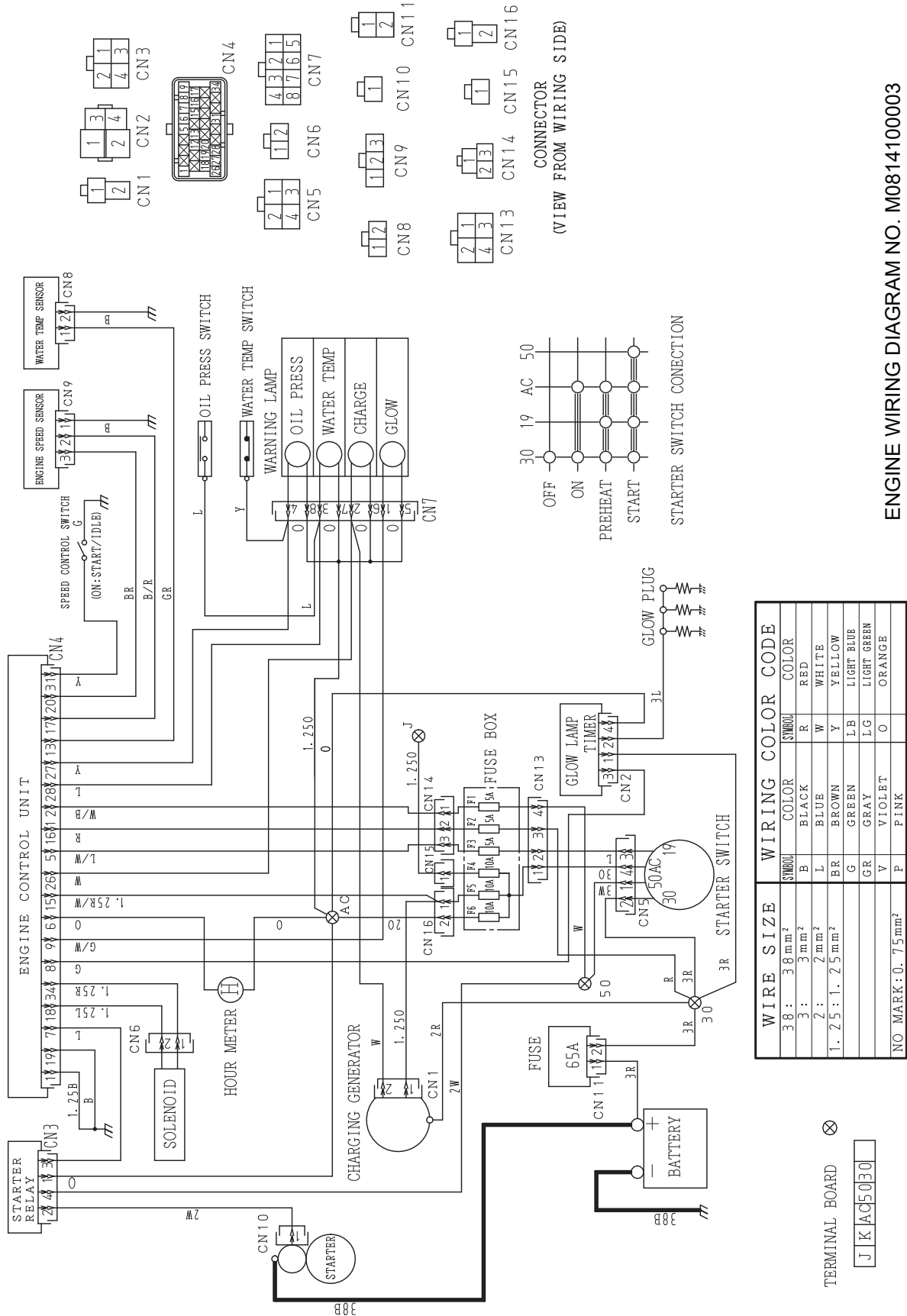

ENGINE WIRING DIAGRAM NO. M0814100003

BATTERY CHARGER WIRING DIAGRAM (OPTION)

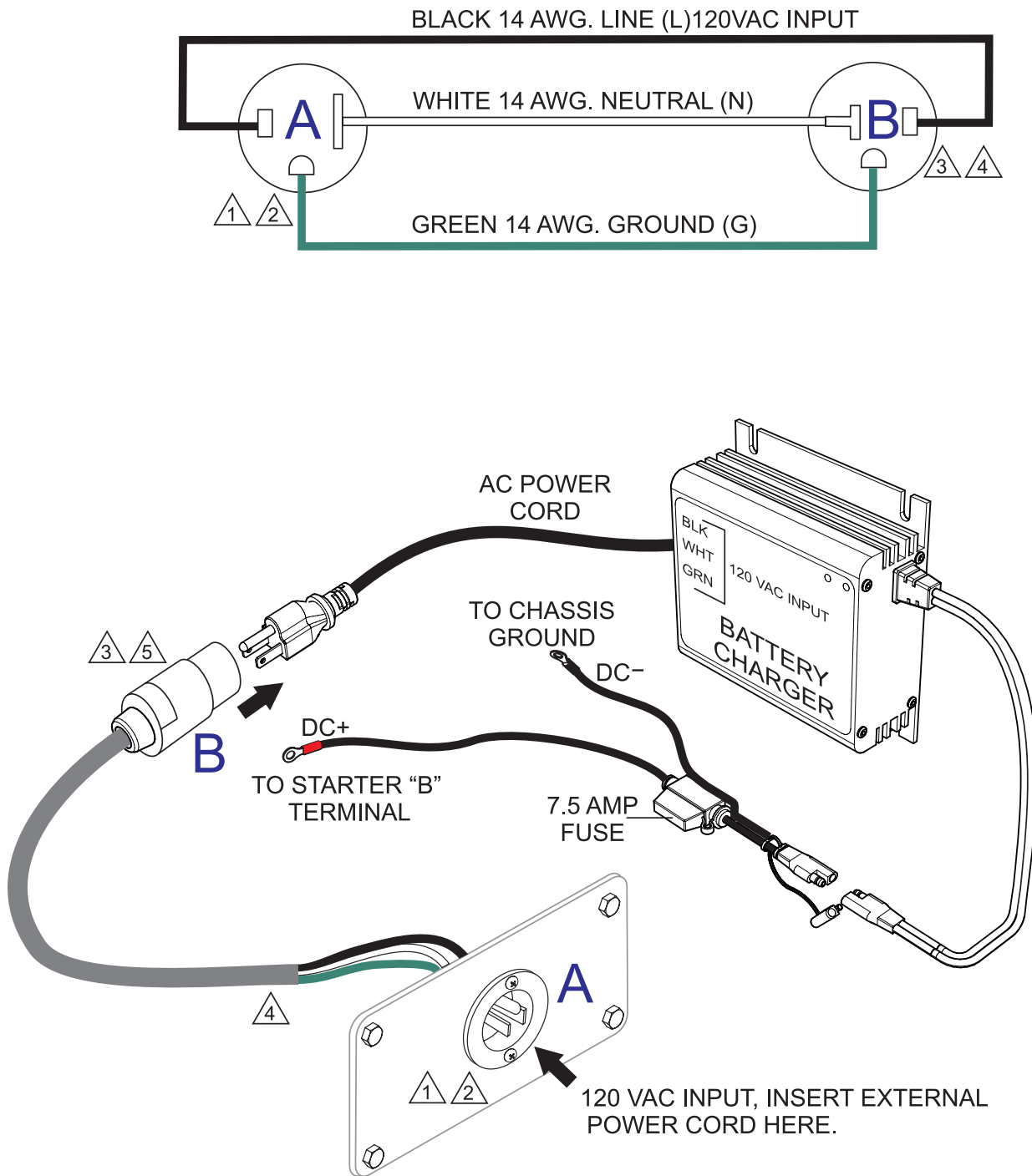

NOTES:

- ① NEMA 5-15, 15A, 120 VAC, P/N EE6176 (HBL5278C/HUBBLE RECEPTACLE).
- ② RECEPTACLE IS MOUNTED ON OUTPUT TERMINAL PANEL ASSY.
- ③ 20 AMP, 5-20R RECEPTACLE, P/N EE6131 (HBL5369C/HUBBLE RECEPTACLE).
- ④ CORD, CAROL 3/C 14 AWG., P/N EE56557.
- ⑤ RECEPTACLE IS MOUNTED UNDERNEATH CONTROL BOX.

ENGINE BLOCK HEATER WIRING DIAGRAM (OPTION)

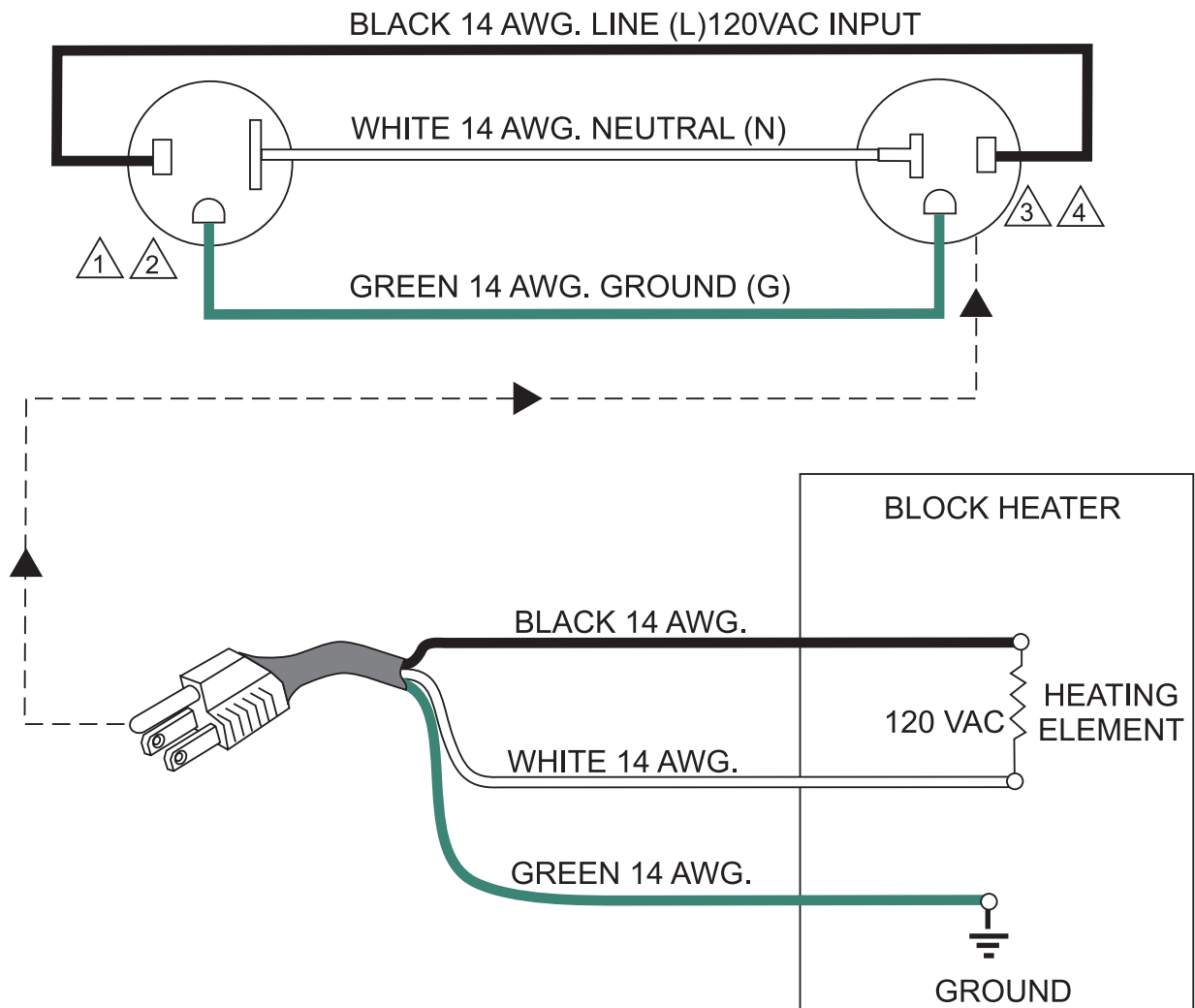

NOTES:

- ① NEMA 5-15, 15A, 120 VAC (HBL5278C/HUBBLE RECEPTACLE)
- ② RECEPTACLE IS MOUNTED ON OUTPUT TERMINAL PANEL ASSY.
- ③ NEMA L5-20R, 20A, 125 VAC (HBL5369C/HUBBLE RECEPTACLE).
- ④ RECEPTACLE IS MOUNTED ADJACENT TO WATER HEATING ELEMENT.

OPERATION MANUAL

HERE'S HOW TO GET HELP

PLEASE HAVE THE MODEL AND SERIAL
NUMBER ON HAND WHEN CALLING

UNITED STATES

Multiquip Inc.

(310) 537- 3700
6141 Katella Avenue Suite 200
Cypress, CA 90630
E-MAIL: mq@multiquip.com
WEBSITE: www.multiquip.com

CANADA

Multiquip

(450) 625-2244
4110 Industriel Boul.
Laval, Quebec, Canada H7L 6V3
E-MAIL: infocanada@multiquip.com

UNITED KINGDOM

Multiquip (UK) Limited Head Office

0161 339 2223
Unit 2, Northpoint Industrial Estate, Globe Lane,
Dukinfield, Cheshire SK16 4UJ
E-MAIL: sales@multiquip.co.uk

© COPYRIGHT 2026, MULTIQUIP INC.

Multiquip Inc., the MQ logo and the MQ Power logo are registered trademarks of Multiquip Inc. and may not be used, reproduced, or altered without written permission. All other trademarks are the property of their respective owners and used with permission.

This manual MUST accompany the equipment at all times. This manual is considered a permanent part of the equipment and should remain with the unit if resold.

DISCLAIMER: Product features, descriptions, and specifications are based on published information at the time of publication and are subject to change at any time without notice. Multiquip Inc. and its affiliates reserve the right to change specifications, features, design, and descriptions of products at any time without notice.

Manufactured for
MQ Power Inc.
by
DENYO MANUFACTURING CORP.

