

# PARTS MANUAL



## **WHISPERWATT™ SERIES MODEL DCA20SPXU4F 60Hz GENERATOR (ISUZU 4LE2T DIESEL ENGINE)**

**PARTS LIST NO. M1871300404M**

Revision #9 (02/13/25)

To find the latest revision of this publication or associated operation manual, visit our website at: [www.mqpower.com](http://www.mqpower.com)



**THIS MANUAL MUST ACCOMPANY THE EQUIPMENT AT ALL TIMES.**

**DCA20SPXU4F  
60Hz Generator**

Explanation Of Code In Remarks Column..... 4  
Suggested Spare Parts ..... 5

**Component Drawings**

Generator Assembly ..... 6-7  
Control Box Assembly .....8-11  
Control Panel Assembly ..... 12-15  
Engine And Radiator Assembly ..... 16-19  
Output Terminal Assembly ..... 20-21  
Battery Assembly ..... 22-23  
Muffler Assembly ..... 24-25  
Fuel Tank Assembly ..... 26-27  
Battery Charger Assembly ..... 28-29  
Jacket Water Heater Assembly ..... 30-31  
Enclosure Assembly ..... 32-37  
Rubber Seals Assembly ..... 38-39  
Nameplate And Decals Assembly..... 40-43

**NOTICE**  
Specifications and part numbers are subject to change without notice.



# EXPLANATION OF CODE IN REMARKS COLUMN

The following section explains the different symbols and remarks used in the Parts section of this manual. Use the help numbers found on the back page of the manual if there are any questions.

## NOTICE

The contents and part numbers listed in the parts section are subject to change without notice. Multiquip does not guarantee the availability of the parts listed.

## SAMPLE PARTS LIST

NO.	PART NO.	PART NAME	QTY.	REMARKS
1	12345	BOLT .....	1	INCLUDES ITEMS W/%
2%		WASHER, 1/4 IN. ....		NOT SOLD SEPARATELY
2%	12347	WASHER, 3/8 IN. ...	1	MQ-45T ONLY
3	12348	HOSE .....	A/R	MAKE LOCALLY
4	12349	BEARING .....	1	S/N 2345B AND ABOVE

## NO. Column

**Unique Symbols** — All items with same unique symbol (@, #, +, %, or >) in the number column belong to the same assembly or kit, which is indicated by a note in the “Remarks” column.

**Duplicate Item Numbers** — Duplicate numbers indicate multiple part numbers, which are in effect for the same general item, such as different size saw blade guards in use or a part that has been updated on newer versions of the same machine.

## NOTICE

When ordering a part that has more than one item number listed, check the remarks column for help in determining the proper part to order.

## PART NO. Column

**Numbers Used** — Part numbers can be indicated by a number, a blank entry, or TBD.

TBD (To Be Determined) is generally used to show a part that has not been assigned a formal part number at the time of publication.

A blank entry generally indicates that the item is not sold separately or is not sold by Multiquip. Other entries will be clarified in the “Remarks” Column.

## QTY. Column

**Numbers Used** — Item quantity can be indicated by a number, a blank entry, or A/R.

A/R (As Required) is generally used for hoses or other parts that are sold in bulk and cut to length.

A blank entry generally indicates that the item is not sold separately. Other entries will be clarified in the “Remarks” Column.

## REMARKS Column

Some of the most common notes found in the “Remarks” Column are listed below. Other additional notes needed to describe the item can also be shown.

**Assembly/Kit** — All items on the parts list with the same unique symbol will be included when this item is purchased.

Indicated by:

“INCLUDES ITEMS W/(unique symbol)”

**Serial Number Break** — Used to list an effective serial number range where a particular part is used.

Indicated by:

“S/N XXXXX AND BELOW”

“S/N XXXX AND ABOVE”

“S/N XXXX TO S/N XXX”

**Specific Model Number Use** — Indicates that the part is used only with the specific model number or model number variant listed. It can also be used to show a part is NOT used on a specific model or model number variant.

Indicated by:

“XXXXX ONLY”

“NOT USED ON XXXX”

**“Make/Obtain Locally”** — Indicates that the part can be purchased at any hardware shop or made out of available items. Examples include battery cables, shims, and certain washers and nuts.

**“Not Sold Separately”** — Indicates that an item cannot be purchased as a separate item and is either part of an assembly/kit that can be purchased, or is not available for sale through Multiquip.

## SUGGESTED SPARE PARTS

### DCA20SPXU4F WHISPERWATT GENERATOR WITH ISUZU 4LE2T DIESEL ENGINE

#### 1 TO 3 UNITS

Qty.	P/N	Description
3	P822769	AIR FILTER (SAFTEY)
3	PMAF25436	ELEMENT, AIR, PRIMARY (INNER)
3	2944566410	ELEMENT, OIL FILTER
5	8982402790	ELEMENT, FUEL FILTER (MAIN)
5	8982402800	ELEMENT, FUEL FILTER (PRE)
5	8981731650	KIT, FEED PUMP FILTER
3	8980490340	BELT, FAN
1	M1311500203	RADIATOR HOSE, UPPER
1	M1311500303	RADIATOR HOSE, LOWER
2	0601870440	CIRCUIT BREAKER, 1P, 20 AMP
2	0601870441	CIRCUIT BREAKER, 2P, 50 AMP
1	0601820626	AUTOMATIC VOLTAGE REGULATOR
2	0601810277	BULB, LAMPS
1	LY2DUS12VDC	RELAY, W/DIODE
1	0601802133	FUSE, 5 AMP
1	Y0601806684	FUSE, 8 AMP
3	0601802149	FUSE, 10 AMP
2	0601806671	FUSE, 15 AMP
1	0601806644	FUSE, 30 AMP
1	0601806640	FUSE, 65 AMP

#### NOTICE

Part number on this Suggested Spare Parts list may supersede/replace the P/N shown in the text pages of this book.

# GENERATOR ASSY.

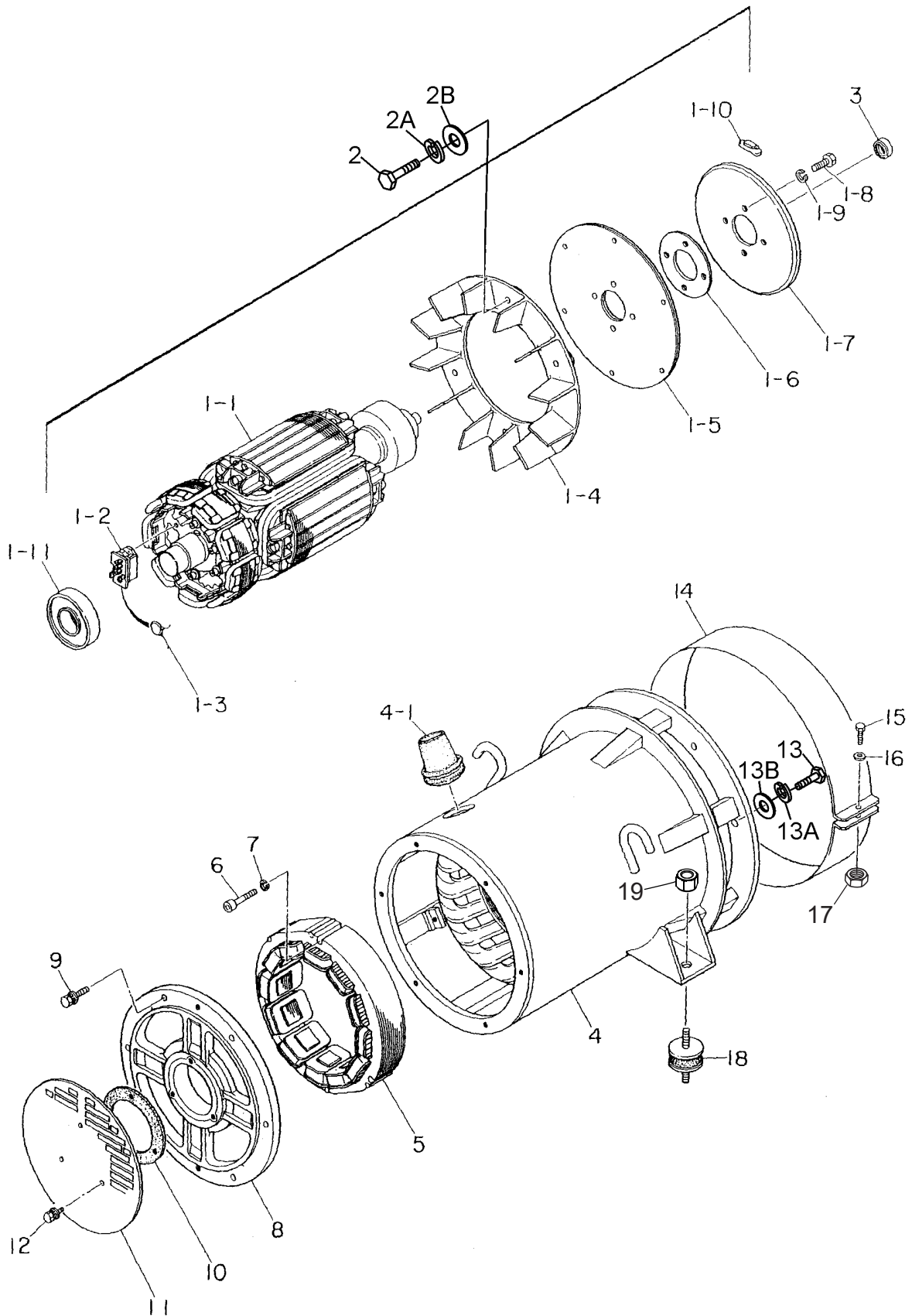

# GENERATOR ASSY.

<u>NO.</u>	<u>PART NO.</u>	<u>PART NAME</u>	<u>QTY.</u>	<u>REMARKS</u>
1	B1110200602	ROTOR ASSY.....	1.....	INCLUDES ITEMS W/%
1-1%		FIELD ASSY.	1	
1-2%	7961025004	RECTIFIER	1	
1-3%	0601822630	SURGE ABSORBER	1	
1-4%	8001070003	FAN	1	
1-5%	8351611004	COUPLING DISK	2	
1-6%	8351612004	WASHER, COUPLING HUB	1	
1-7%	B1112300003	BALANCING PLATE .....	1.....	ITEM 1-10 MUST BE ORDERED WHEN REPLACING THE BALANCING PLATE
1-8%	0105091025	HEX. HEAD BOLT .....	4.....	REPLACES P/N 0010310025
1-9%	030210250	WASHER, LOCK .....	4.....	REPLACES P/N 0042510000
1-10%	0601000209	BALANCING WEIGHT KIT	1	
1-11%	042006308	BEARING.....	1.....	REPLACES P/N 0071906308
2	0010308035	HEX. HEAD BOLT	6	
2A	0040008000	WASHER, LOCK	6	
2B	0401450080	WASHER, FLAT.....	6.....	REPLACES P/N 0041208000
3	0070506803	BEARING	1	
4	B1130201103	STATOR ASSY. ....	1.....	INCLUDES ITEMS W/#
4-1#	0845041904	GROMMET	1	
5	B1138000003	FIELD ASSY., EXCITER	1	
6	0016008045	HEX. SOCKET HEAD CAP SCREW	3	
7	0042508000	WASHER, LOCK	3	
8	8351315003	END BRACKET	1	
9	0017108035	HEX. HEAD BOLT	6	
10	8351312004	PACKING	1	
11	8351331004	COVER, SUCTION	1	
12	011106015	HEX. HEAD BOLT .....	3.....	REPLACES P/N 0017106015
13	012010030	HEX. HEAD BOLT .....	6.....	REPLACES P/N 0010310030
13A	031110160	WASHER, FLAT.....	6.....	REPLACES P/N 0041210000
14	B0155400204	COVER, FAN	1	
15	0010006030	HEX. HEAD BOLT .....	1.....	REPLACES P/N 0010106030
16	952404470	WASHER, FLAT.....	1.....	REPLACES P/N 0041206000
17	020106050	NUT.....	1.....	REPLACES P/N 0600815000
18	Y0605000409	RUBBER SUSPENSION	2	
19	021112140	SELF-LOCKING NUT .....	2.....	REPLACES P/N 0207010000

# CONTROL BOX ASSY.

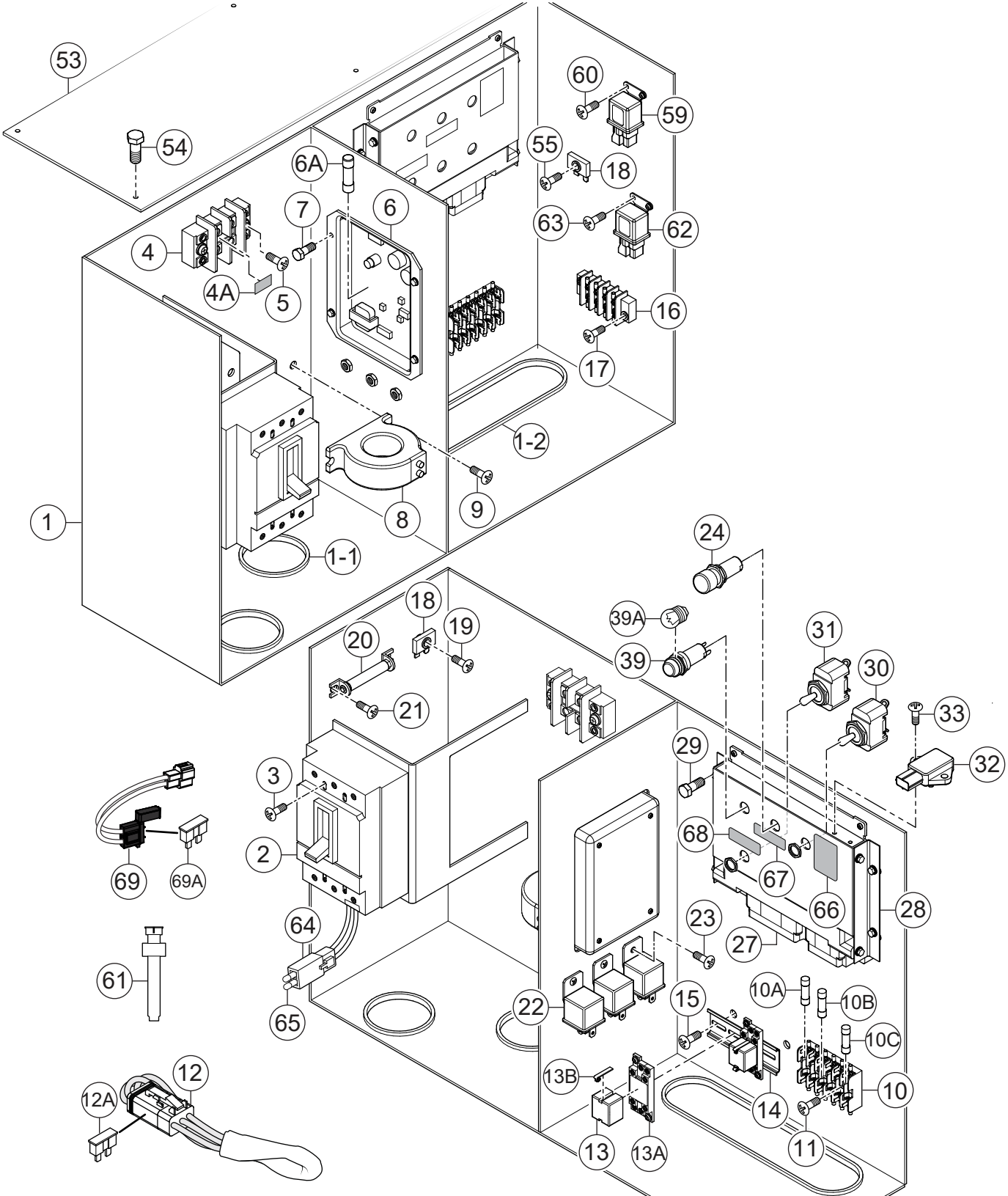



## CONTROL BOX ASSY.

<u>NO.</u>	<u>PART NO.</u>	<u>PART NAME</u>	<u>QTY.</u>	<u>REMARKS</u>
1	M1214000502	CONTROL BOX	1	
1-1	0411100205	EDGING	2	
1-2	0411100475	EDGING	1	
2	0601870433	CIRCUIT BREAKER, 3P 90A	1	
3	0021004075	MACHINE SCREW	4	
4	0601815870	TERMINAL	1	
4A	M9521000404	DECAL; TERMINAL	1	
5	0027104020	MACHINE SCREW	2	
6	0601820626	AUTOMATIC VOLTAGE REGULATOR .....	1	INCLUDES ITEMS W/#
6A#	Y0601806684	FUSE, 250V 8A	1	
7	0027105015	MACHINE SCREW	4	
8	0601801123	CURRENT TRANSFORMER	2	
9	011206020	MACHINE SCREW .....	4	REPLACES P/N 0027106020
10	0601802218	HOLDER, FUSE 3P .....	2	S/N 8720725 AND BELOW
			2	S/N 8720800 AND ABOVE
10	0601818021	HOLDER, FUSE 2P .....	2	S/N 8720726 ~ 8720799
10	0601818020	HOLDER, FUSE 1P .....	2	S/N 8720726 ~ 8720799
10A	0601806671	FUSE, 15A	2	
10B	0601802149	FUSE, 10A	3	
10C	0601802133	FUSE, 5A	1	
11	0027103015	MACHINE SCREW .....	2	S/N 8720725 AND BELOW
11	0027103010	MACHINE SCREW .....	4	S/N 8720726 AND ABOVE
12	M2357202104	HOLDER, FUSE	1	
12A	0601806644	FUSE, 30A	1	
13	LY2DUS12VDC	RELAY, DC12V .....	2	REPLACES P/N 0601827656
13	LY2DUS12VDC	RELAY, DC12V .....	1	REPLACES P/N 0601827656
				S/N 8720441 AND ABOVE
13A	PTF08A	BASE .....	2	REPLACES P/N 0601823109
13A	PTF08A	BASE .....	1	REPLACES P/N 0601823109
				S/N 8720441 AND ABOVE
13B	PYCA1	CLIP .....	4	REPLACES P/N 0601824400
13B	PYCA1	CLIP .....	2	REPLACES P/N 0601824400
				S/N 8720441 AND ABOVE
14	Y0290000100	MOUNTING RAIL	1	
15	0027104010	MACHINE SCREW	2	
16	0601815153	TERMINAL BLOCK, 603-GP-04 .....	1	S/N 8720705 AND BELOW
16	Y0601816538	TERMINAL BLOCK, TB400-04 .....	1	S/N 8720706 AND ABOVE
17	0027104020	MACHINE SCREW	2	
18	0601821370	RECTIFIER .....	3	REPLACES P/N 0601823240
18	0601821370	RECTIFIER .....	3	REPLACES P/N 0601823240
19	0027104020	MACHINE SCREW	1	
20	0601842384	RESISTOR, 50Ω	1	

# CONTROL BOX ASSY. (CONT'D.)

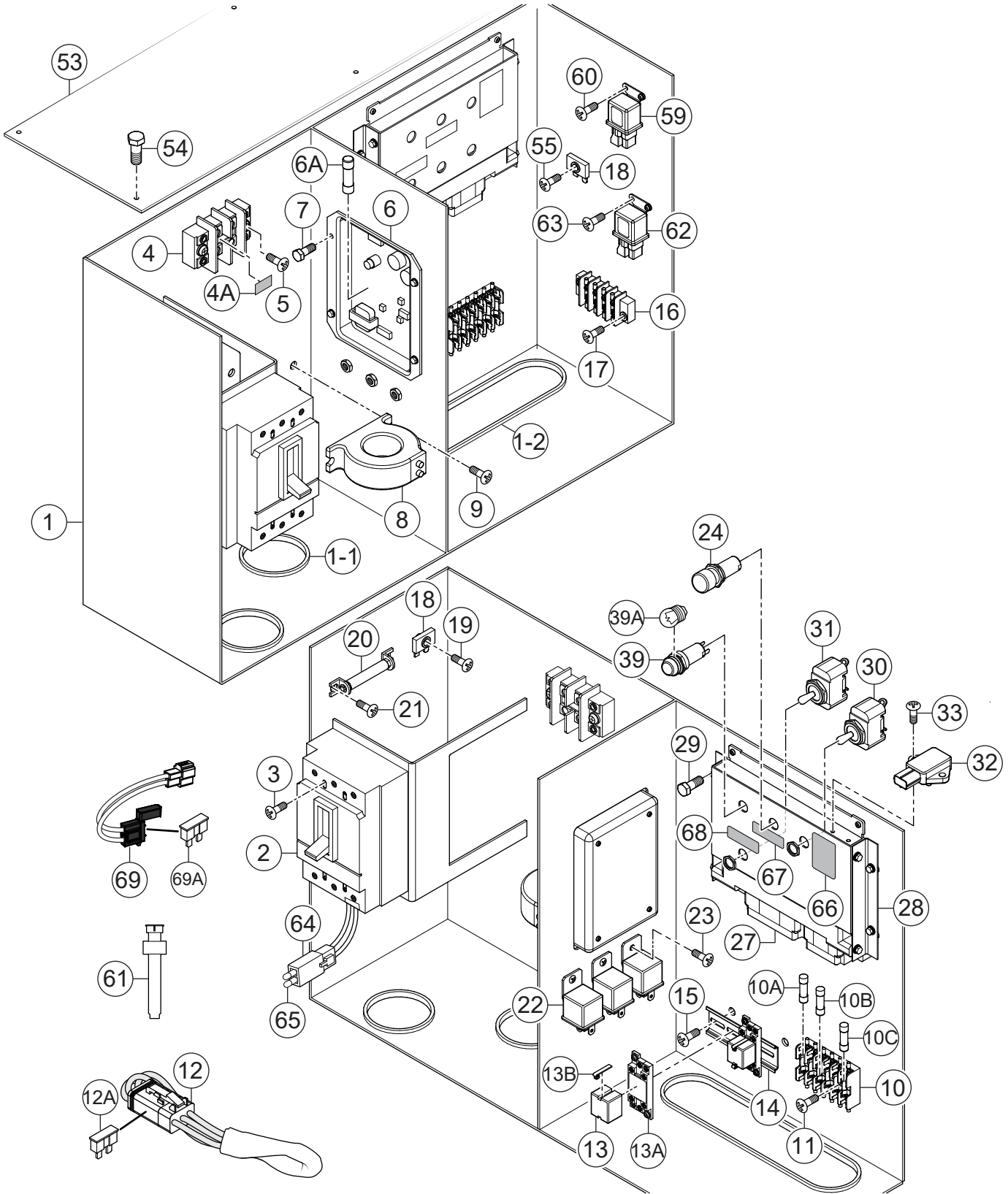

## CONTROL BOX ASSY. (CONT'D.)

<u>NO.</u>	<u>PART NO.</u>	<u>PART NAME</u>	<u>QTY.</u>	<u>REMARKS</u>
21	0027104010	MACHINE SCREW .....	2	REPLACES P/N 0602201400
22	5825500290	RELAY	3	
23	0027105010	MACHINE SCREW	3	
24	0601831205	PUSH BUTTON SWITCH	1	
27	Y0602202699	ENGINE CONTROLLER (ECM)	1	
28	M1214600204	CONTROLLER BRACKET	1	
29	011106015	HEX. HEAD BOLT.....	8	REPLACES P/N 0016906015
30	0601830710	DIAGNOSTIC SWITCH	1	
31	0601830762	FUEL PUMP SWITCH	1	
32	8972177780	BAROMETRIC PRESSURE SENSOR.....	1	REPLACES P/N 0602130220
33	0027105015	MACHINE SCREW	2	
39	0602103092	ALARM LAMP .....	1	INCLUDES ITEMS W/# S/N 8720565 AND BELOW
39	0601814453	ALARM LED LAMP .....	1	S/N 8720566 AND ABOVE
39A#	0601810277	BULB.....	1	S/N 8720565 AND BELOW
53	M1214500004	CONTROL BOX COVER	1	
54	0016906015	HEX. HEAD BOLT.....	4	REPLACES P/N 0016906015
55	0027104030	MACHINE SCREW	1	
59	8944001061	RELAY, STARTER .....	1	REPLACES P/N 0602202502
60	0027105010	MACHINE SCREW	2	
61	0601806640	FUSE, 65A	1	
62	8970119490	GLOW PLUG RELAY.....	1	REPLACES P/N 0602202685
63	0027105010	MACHINE SCREW	2	
64	0601812626	PLUG	1	
65	0601812712	PINS MALE	2	
66	M9520000904	DECAL; DIAGNOSTIC SWITCH	1	
67	M9520001104	DECAL; DIAGNOSTIC BUTTON	1	
68	M9520002104	DECAL; FUEL PUMP SWITCH	1	
69	C3358201704	FUSE HOLDER ASSY. ....	1	REPLACES P/N M2357202104 S/N 8720441 AND ABOVE
69A	0601806645	FUSE .....	1	S/N 8720441 AND ABOVE

# CONTROL PANEL ASSY.

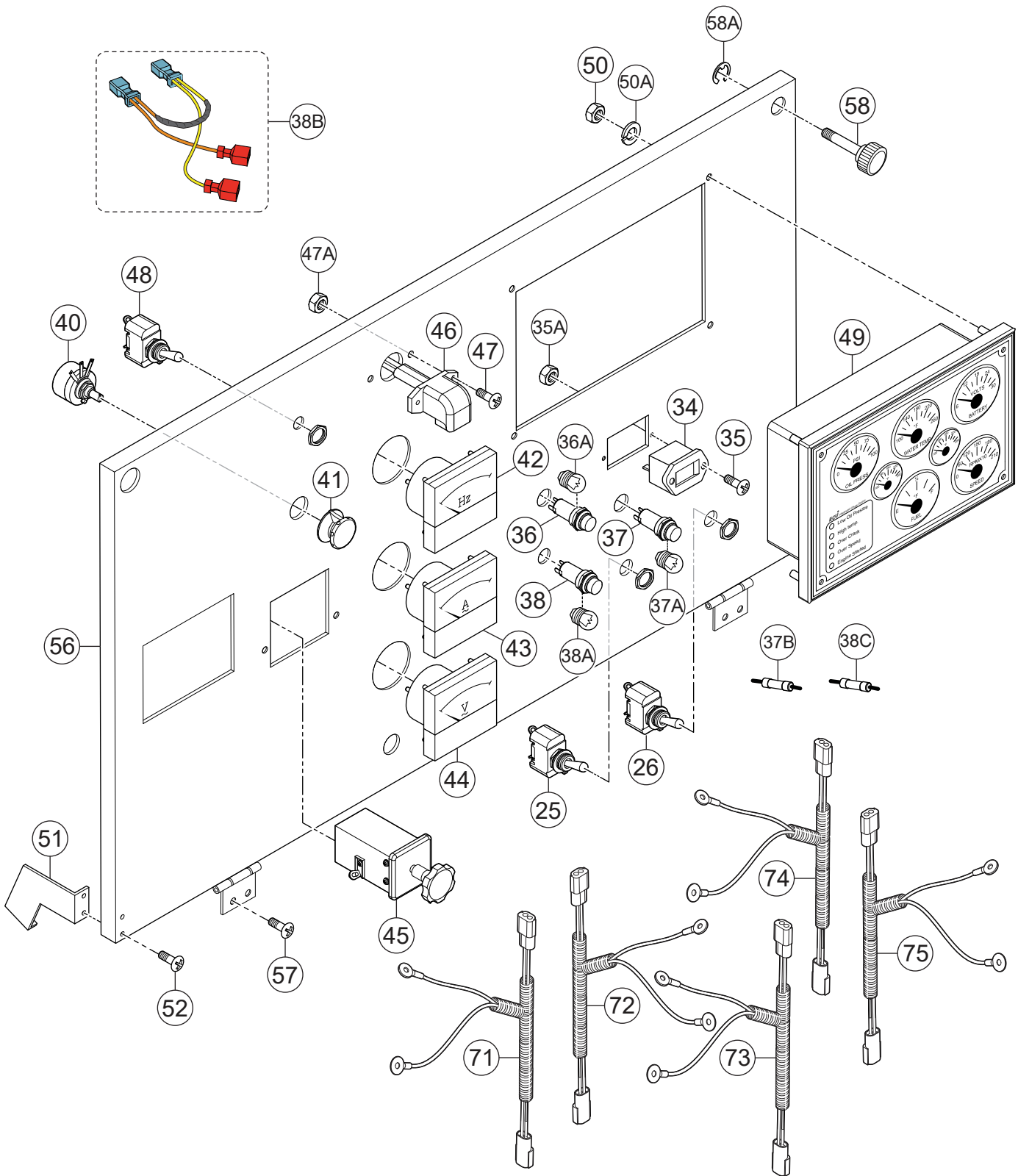

## CONTROL PANEL ASSY.

<u>NO.</u>	<u>PART NO.</u>	<u>PART NAME</u>	<u>QTY.</u>	<u>REMARKS</u>
25	82608	AUTO START/STOP SWITCH.....	1.....	REPLACES P/N 0601831340 S/N 8720817 AND BELOW
25	Y0601831345	AUTO START/STOP SWITCH.....	1.....	S/N 8720818 AND ABOVE
26	0601830710	ENGINE SPEED SWITCH	1	
34	0601800682	HOUR METER .....	1.....	S/N 8720675 AND BELOW
34	Y0601800674	HOUR METER.....	1.....	S/N 8720676 AND ABOVE
35	0027103015	MACHINE SCREW	2	
35A	0207003000	SELF-LOCKING NUT	2	
36	0602103092	FUEL LEAK DETECTED ALARM LAMP .....	1.....	INCLUDES ITEMS W/\$ S/N 8720565 AND BELOW
36	Y0601814453	FUEL LEAK DETECTED LED LAMP.....	1.....	S/N 8720566 AND ABOVE
36A\$	0601810277	BULB	1	
37	0602103092	PREHEAT LAMP .....	1.....	INCLUDES ITEMS W/% S/N 8720565 AND BELOW
37	Y0601814453	LED PREHEAT LAMP.....	1.....	S/N 8720566 AND ABOVE
37A%	0601810277	BULB	1	
37B	Y0601842542	RESISTOR.....	1.....	S/N 8720566 AND ABOVE
38	0602103092	WARNING LAMP .....	1.....	INCLUDES ITEMS W/@ S/N 8720565 AND BELOW
38	Y0601814453	WARNING LED LAMP.....	1.....	S/N 8720566 AND ABOVE
38A@	0601810277	BULB .....	1.....	S/N 8720565 AND BELOW
38B	M1358203504	RESISTOR HARNESS .....	1.....	S/N 8720566 AND ABOVE
38C	Y0601842542	RESISTOR.....	1.....	S/N 8720586 AND ABOVE
40	0601840073	RHEOSTAT, VOLTAGE REG. 2W 1KΩ	1	
41	0601840100	KNOB.....	1.....	REPLACES P/N 0601840121
42	0601807641	FREQUENCY METER, 45~65HZ 240V	1	
43	0601806844	AC AMMETER, 0~50A, 0~150A	1	
44	0601800271	AC VOLTMETER, 0~300V	1	
45	0601801040	CHANGE-OVER SWITCH, AMMETER	1	
46	Y0601810170	PANEL LIGHT	1	
47	0027104015	MACHINE SCREW	2	
47A	OEMAA8	SELF-LOCKING NUT .....	2.....	REPLACES P/N 0207004000
48	0601830710	PANEL LIGHT SWITCH	1	
49	Y0602202653	CONTROLLER, ECU-750.....	1.....	S/N 8720455 AND BELOW
49	Y0602203045	CONTROLLER, ECU-754.....	1.....	REPLACES P/N Y0602202653 S/N 8720456 ~ 8720495
49	Y0602203074	CONTROLLER, ECU-754.....	1.....	S/N 8720596 ~ 8720781
49	Y0602203084	CONTROLLER, ECU-755.....	1.....	S/N 8720782 AND ABOVE
50	Y0206707000	HEX. NUT	4	
50A	Y0044807000	WASHER, LOCK	4	

# CONTROL PANEL ASSY. (CONT'D.)

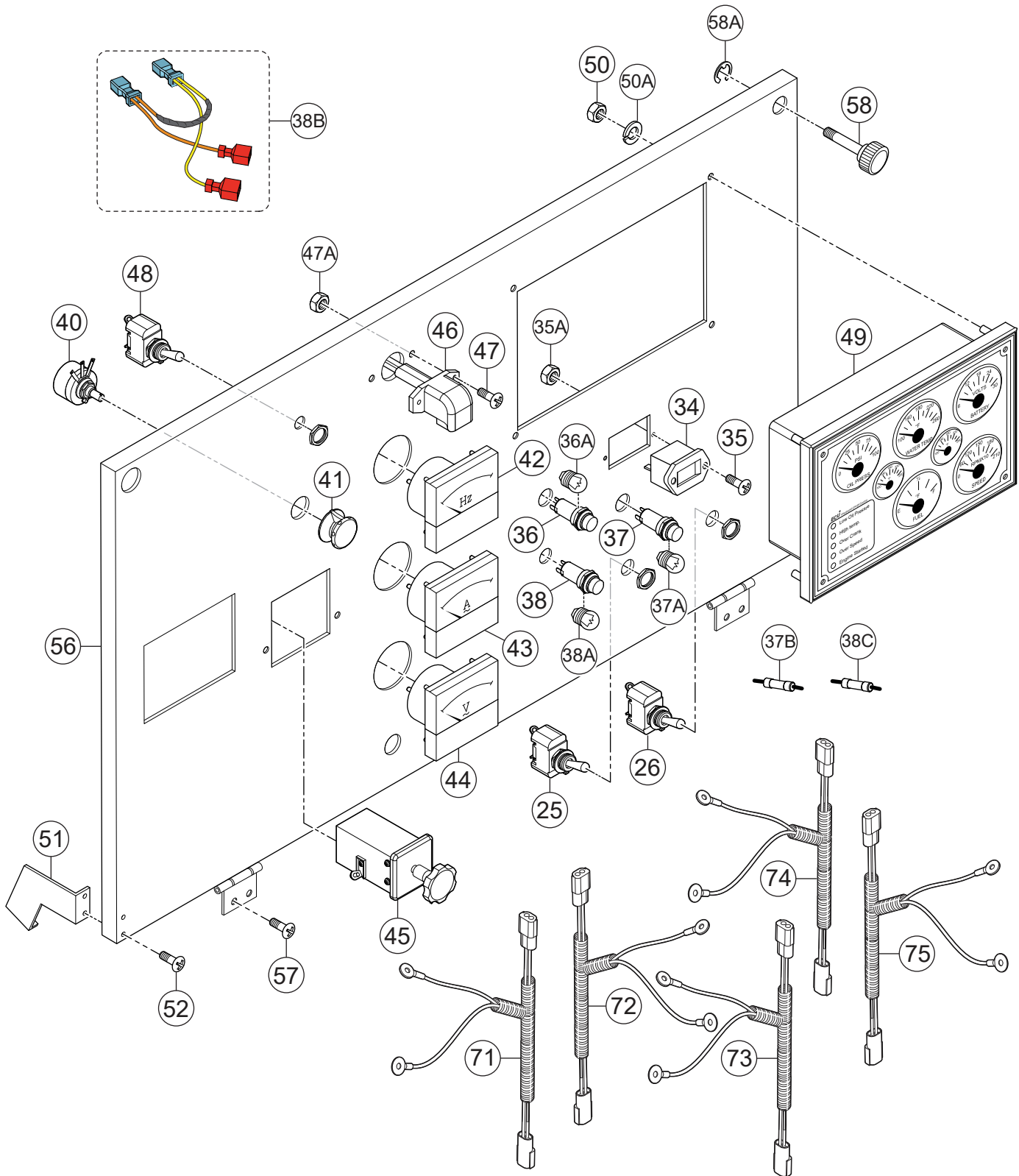

## CONTROL PANEL ASSY. (CONT'D.)

<u>NO.</u>	<u>PART NO.</u>	<u>PART NAME</u>	<u>QTY.</u>	<u>REMARKS</u>
51	M1223100104	STOPPER	1	
52	0027105015	MACHINE SCREW	2	
56	M1224000103	CONTROL PANEL	1	
57	0027105010	MACHINE SCREW	4	
58	M9220100004	SET SCREW	2	
58A	0080200007	E-SNAP RING	2	
71	M1247700504	WIRE HARNESS GENERATOR	1	
72	M1358201602	WIRE HARNESS, ENGINE .....	1	S/N 8720781 AND BELOW
72	M1358203712	WIRE HARNESS, ENGINE .....	1	S/N 8720782 AND ABOVE
73	M1358200302	WIRE HARNESS CONTROLLER.....	1	S/N 8720745 AND BELOW
73	M1358200312	WIRE HARNESS CONTROLLER.....	1	S/N 8750746 AND ABOVE
74	M1358202004	WIRE HARNESS, PRESSURE SWITCH .....	1	S/N 8720441 ~ 8720781
75	8983346920	WIRE HARNESS, PCV HEATER .....	1	REPLACES P/N Y0602044310 S/N 8720441 AND ABOVE

# ENGINE AND RADIATOR ASSY.

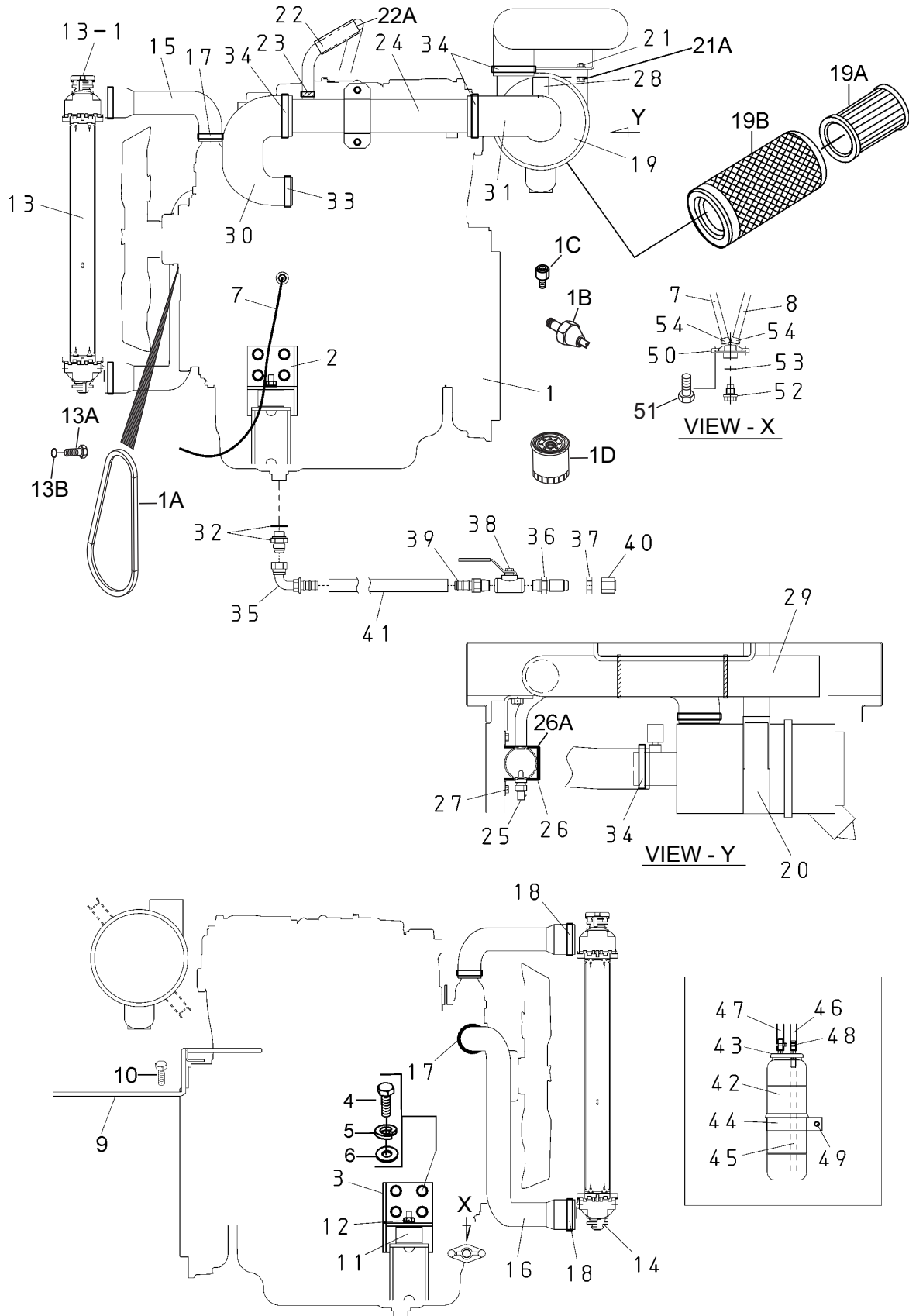



## ENGINE AND RADIATOR ASSY.

<u>NO.</u>	<u>PART NO.</u>	<u>PART NAME</u>	<u>QTY.</u>	<u>REMARKS</u>
1	M1924200074	ENGINE, ISUZU 4LE2T .....	1.....	INCLUDES ITEMS W/#
1A#	8980490340	BELT, FAN	1	
1B#	8983193760	PRESSURE SWITCH.....	1.....	REPLACES P/N Y0602210060 S/N 8720441 AND ABOVE
1C#	0602211629	ADAPTER.....	1.....	S/N 8720441 AND ABOVE
1D#	2944566410	ELEMENT, OIL FILTER	1	
2	M1303200304	ENGINE FOOT	1	
3	M1305200204	ENGINE FOOT	1	
4	0105091025	HEX. HEAD BOLT.....	8.....	REPLACES P/N 0010310025
5	0040010000	WASHER, LOCK	8	
6	031110160	WASHER, FLAT.....	8.....	REPLACES P/N 0041210000
7	0199900900	DRAIN HOSE	1	
8	Y0199900680	DRAIN HOSE	1	
9	M1358300403	CLAMPER ROD	1	
10	012210020	HEX. HEAD BOLT.....	2.....	REPLACES P/N 0017110020
11	Y0605000408	RUBBER SUSPENSION	2	
12	021112140	HEX. NUT .....	2.....	REPLACES P/N 0207010000
13	M1924200164	RADIATOR .....	1.....	INCLUDES ITEMS W/%
13A	M9200100904	PLUG	1	
13B	0150000016	O-RING	1	
13-1%	Y0602015700	CAP	1	
14	M9312200104	MOUNT RUBBER	4	
15	M1311500203	RADIATOR HOSE, UPPER	1	
16	M1311500303	RADIATOR HOSE, LOWER	1	
17	0605515149	HOSE BAND	2	
18	0605515147	HOSE BAND	2	
19	Y0602046590	AIR CLEANER .....	1.....	INCLUDES ITEMS W/\$
19A\$	0602046309	PRIMARY ELEMENT	1	
19B\$	0602046689	SAFETY ELEMENT	1	
20	Y0602040553	AIR CLEANER BAND	1	
21	011208030	HEX. HEAD BOLT.....	2.....	REPLACES P/N 0016908030
21A	020108060	SELF-LOCKING-NUT .....	2.....	REPLACES P/N 0207008000
22	0269200520	PUSH-LOCK-HOSE .....	1.....	S/N 8720440 AND BELOW
22	M1327200004	BLOW-BY HOSE .....	1.....	S/N 8720441 AND ABOVE
22A	0378100160	AEROFLEX .....	1.....	S/N 8720441 AND ABOVE
23	0605515198	HOSE BAND .....	2.....	S/N 8720440 AND BELOW
23	0605515198	HOSE BAND.....	1.....	S/N 8720441 AND ABOVE
23	0605515321	HOSE BAND.....	1.....	S/N 8720441 AND ABOVE
24	M1374000003	AIR CLEANER PIPE .....	1.....	S/N 8720440 AND BELOW
24	M1374000013	AIR CLEANER PIPE.....	1.....	S/N 8720441 AND ABOVE
24A	8981924670	PCV HEATER.....	1.....	REPLACES P/N Y0602044300 S/N 8720441 AND ABOVE
25	8121468300	INLET AIR TEMPERATURE SENSOR.....	1.....	REPLACES P/N 0603210240
26	M1374200204	BRACKET, AIR CLEANER PIPE	1	
26A	Y0222100060	RUBBER SEAL	1	

# ENGINE AND RADIATOR ASSY. (CONT'D.)

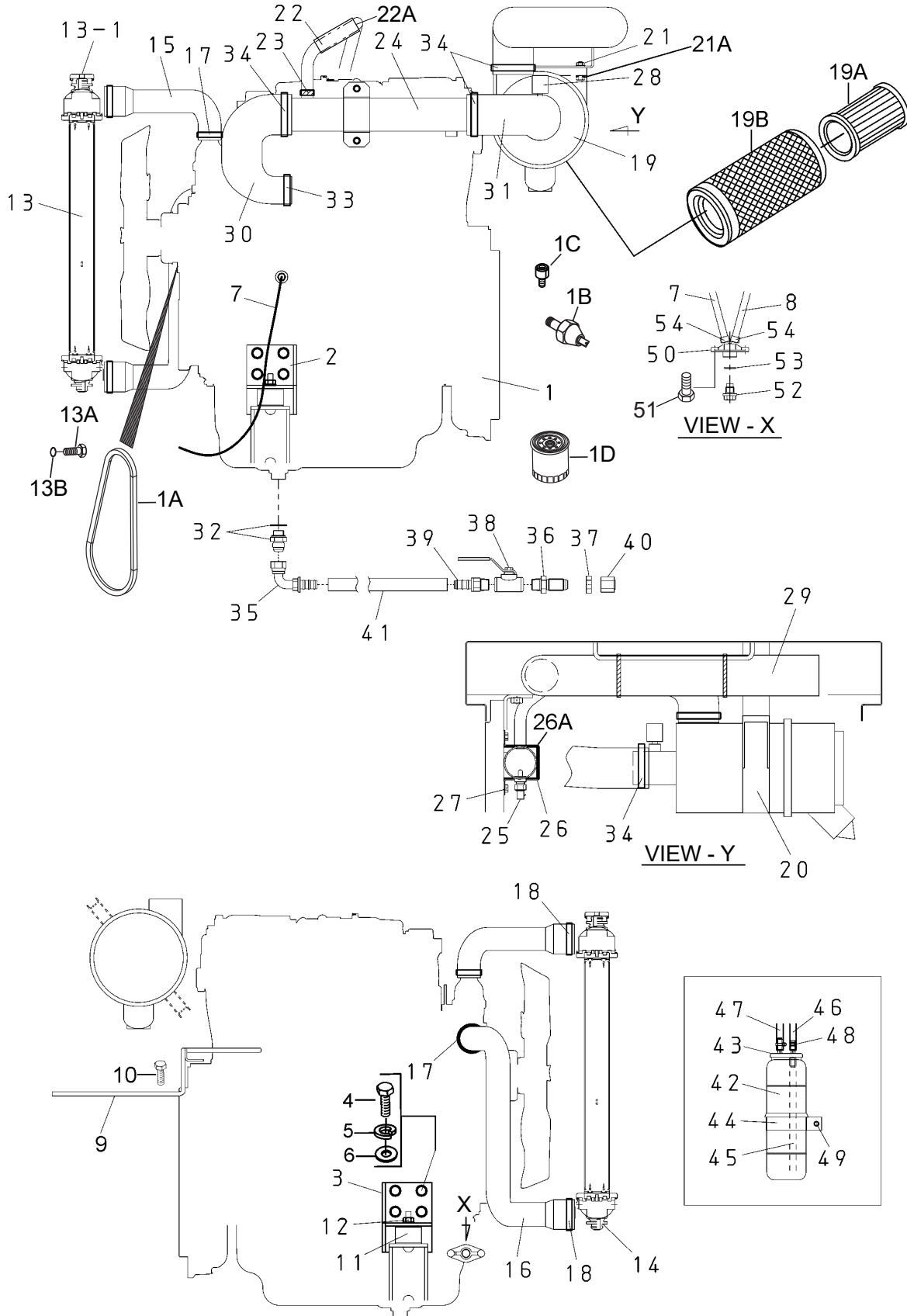

## ENGINE AND RADIATOR ASSY. (CONT'D.)

<u>NO.</u>	<u>PART NO.</u>	<u>PART NAME</u>	<u>QTY.</u>	<u>REMARKS</u>
27	011008020	HEX. HEAD BOLT.....	2.....	REPLACES P/N 0016908020
28	0602040651	INDICATOR, AIR CLEANER	1	
29	M1374100203	AIR CLEANER HOSE	1	
30	M1374100303	AIR CLEANER HOSE	1	
31	M1374100403	AIR CLEANER HOSE	1	
32	0602022581	ADAPTER 10M 24 X 2. 0	1	
33	0605515147	HOSE BAND	1	
34	9500202080	HOSE BAND.....	4.....	REPLACES P/N 0605515178
35	0602022561	90° ELBOW .....	1.....	S/N 8720565 AND BELOW
36	0603306590	CONNECTOR	1	
37	0603300285	LOCKNUT	1	
38	0605511395	VALVE	1	
39	0603306395	HOSE JOINT .....	1.....	S/N 8720565 AND BELOW
40	0602021070	CAP	1	
41	0269200600	DRAIN HOSE .....	1.....	S/N 8720565 AND BELOW
41	M1321100104	DRAIN HOSE.....	1.....	S/N 8720566 AND ABOVE
42	0802081403D	RESERVE TANK .....	1.....	REPLACES P/N M9300000003
43	0802081104	CAP, RESERVE TANK .....	1.....	REPLACES P/N M9300100003
44	M1317100004	BRACKET, RESERVE TANK	1	
45	0199100215	HOSE	1	
46	Y0199900520	OVER FLOW HOSE	1	
47	0193601100	OVER FLOW HOSE	1	
48	0605515189	HOSE BAND	2	
49	011008020	HEX. HEAD BOLT .....	1.....	REPLACES P/N 0016908020
50	1622014103	DRAIN JOINT .....	1.....	REPLACES P/N M9602000003
51	011206020	HEX. HEAD BOLT .....	2.....	REPLACES P/N 0016906020
52	0802011104	DRAIN BOLT .....	1.....	REPLACES P/N M9200200004
53	0150000018	O-RING	1	
54	0605515189	HOSE BAND	4	

# OUTPUT TERMINAL ASSY.

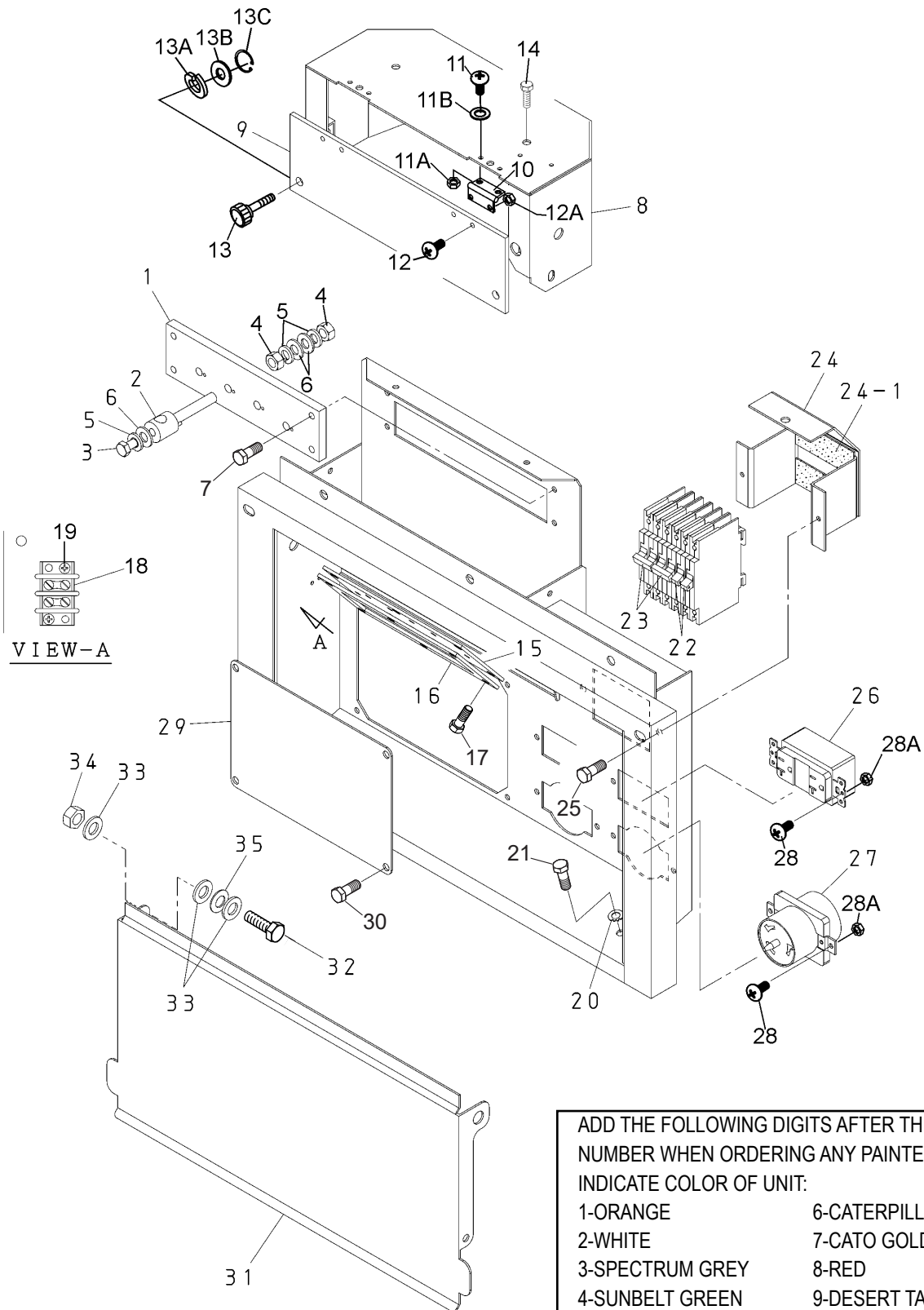

ADD THE FOLLOWING DIGITS AFTER THE PART NUMBER WHEN ORDERING ANY PAINTED PANEL TO INDICATE COLOR OF UNIT:

1-ORANGE	6-CATERPILLAR YELLOW
2-WHITE	7-CATO GOLD
3-SPECTRUM GREY	8-RED
4-SUNBELT GREEN	9-DESERT TAN
5-BLACK	

THE SERIAL NUMBER MAY BE REQUIRED.

## OUTPUT TERMINAL ASSY.

<u>NO.</u>	<u>PART NO.</u>	<u>PART NAME</u>	<u>QTY.</u>	<u>REMARKS</u>
1	M1230700203	TERMINAL PANEL	1	
2	M9220000204	OUTPUT TERMINAL BOLT	4	
3	M9220000104	TIE BOLT	4	
4	0039308000	HEX. NUT	8	
5	0040008000	WASHER, LOCK	12	
6	0041408000	WASHER, FLAT	16	
7	011606025	HEX. HEAD BOLT .....	4	REPLACES P/N 0016906025
8	M1237100103	3-PHASE OUTPUT TERMINAL	1	
9	M1236100404	OUTPUT WINDOW	1	
10	0605010040	HINGE	2	
11	0027103010	MACHINE SCREW	4	
11A	0207003000	HEX. NUT .....	4	REPLACES P/N 0030003000
11B	0041203000	WASHER, FLAT	4	
12	0027103010	MACHINE SCREW	4	
12A	0207003000	HEX. NUT .....	4	REPLACES P/N 0030003000
13	M9220100804	SET SCREW	2	
13A	0040006000	WASHER, LOCK	2	
13B	952404470	WASHER, FLAT .....	2	REPLACES P/N 0041206000
13C	0080200005	E-SNAP RING	2	
14	011106015	HEX. HEAD BOLT .....	4	REPLACES P/N 0016906015
15	M1236400004	CABLE OUTLET COVER	1	
16	M1236300004	SUPPORTER, CABLE OUTLET COVER	1	
17	011206020	HEX. HEAD BOLT .....	6	REPLACES P/N 0016906020
18	Y0601816539	TERMINAL BLOCK, 601-GP-02 .....	1	REPLACES P/N 0601815194 S/N 8720705 AND BELOW
18	0601816039	TERMINAL BLOCK, TB200-02 .....	1	S/N 8720706 ~ 8720735
18	0601815870	TERMINAL BLOCK, KT-20-2P .....	1	S/N 8720736 AND ABOVE
19	7538070	MACHINE SCREW .....	2	REPLACES P/N 0027104015
20	0040508000	TOOTHED WASHER	1	
21	0019208020	HEX. HEAD BOLT	1	
22	0601870440	CIRCUIT BREAKER, 1P 20A	2	
23	0601870441	CIRCUIT BREAKER, 2P 50A	2	
24	M1260700404	BREAKER FITTING COVER	1	
24-1	0222100080	CUSHION RUBBER	2	
25	011206020	HEX. HEAD BOLT .....	2	REPLACES P/N 0016906020
26	Y0601814034	RECEPTACLE, 125V 20A	2	
27	Y0601814014	RECEPTACLE, 250V 50A	2	
28	7538070	MACHINE SCREW .....	8	REPLACES P/N 0027104015
28A	OEMAA8	HEX. NUT .....	8	REPLACES P/N 0207004000
29	M1236400104	COVER	1	
30	011106015	HEX. HEAD BOLT .....	4	REPLACES P/N 0016906015
31	M1237100003	TERMINAL COVER	1	
32	012212045	HEX. HEAD BOLT .....	2	REPLACES P/N 0010112045
33	031112230	WASHER, FLAT .....	6	REPLACES P/N 0041212000
34	0030012000	HEX. NUT	2	
35	0605050060	CONICAL LOCK WASHER	2	

**BATTERY ASSY.**

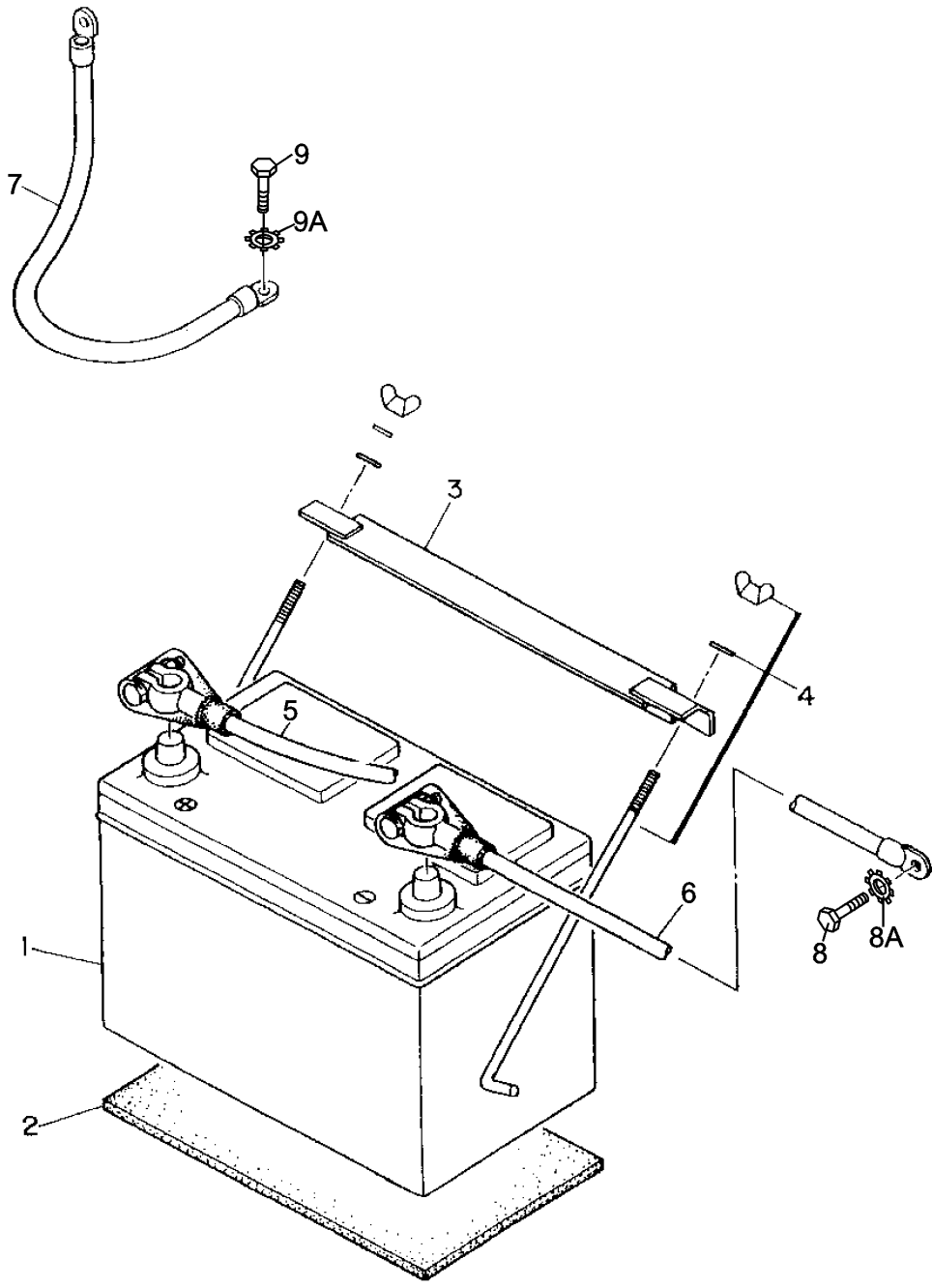

## BATTERY ASSY.

---

<u>NO.</u>	<u>PART NO.</u>	<u>PART NAME</u>	<u>QTY.</u>	<u>REMARKS</u>
1	0602220185	BATTERY	1	
2	M9310500014	BATTERY SHEET	1	
3	M9103000304	BATTERY BAND	1	
4	0602220920	BATTERY BOLT SET	2	
5	M1346400004	BATTERY CABLE	1	
6	M2346900304	BATTERY CABLE	1	
7		CABLE .....	1	PURCHASE LOCALLY
8	0016910025	HEX. HEAD BOLT	1	
8A	0040510000	TOOTHED WASHER	1	
9	011208025	HEX. HEAD BOLT.....	1	REPLACES P/N 0016908025
9A	0040508000	TOOTHED WASHER	1	

# MUFFLER ASSY.

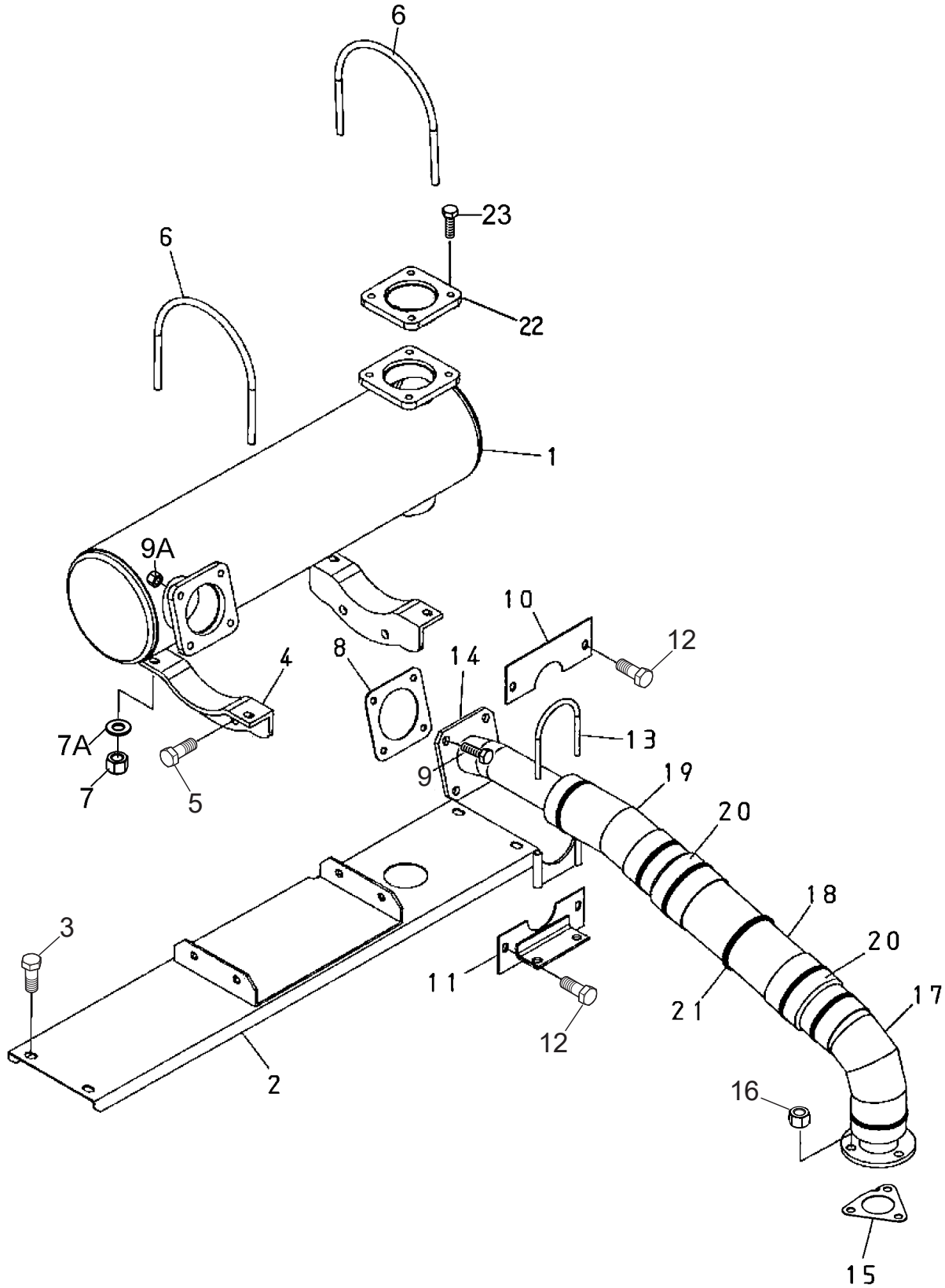



## MUFFLER ASSY.

<u>NO.</u>	<u>PART NO.</u>	<u>PART NAME</u>	<u>QTY.</u>	<u>REMARKS</u>
1	8982353890	DOC.....	1.....	REPLACES P/N Y0602330111
2	M1331400103	DOC BRACKET	1	
3	0016908020	HEX. HEAD BOLT	4	
4	8982284330	DOC SUPPORT.....	2.....	REPLACES P/N Y0602330210
5	0016910025	HEX. HEAD BOLT	4	
6	8982103230	U-BOLT.....	2.....	REPLACES P/N Y0602322091
7	0037908000	SELF-LOCKING NUT	4	
7A	0041208000	WASHER, FLAT	4	
8	8973731080	GASKET.....	1.....	REPLACES P/N Y0602320212
9	8980435280	HEX. HEAD BOLT.....	4.....	REPLACES P/N Y0602322090
9A	8971616070	HEX. NUT.....	4.....	REPLACES P/N Y0602323007
10	M1331400204	COVER, EXHAUST PIPE	1	
11	M1331400304	BRACKET, EXHAUST PIPE	1	
12	0016906015	HEX. HEAD BOLT	4	
13	Y0602326066	U-BOLT	1	
14	M1334000703	EXHAUST PIPE	1	
15	8973679180	GASKET.....	1.....	REPLACES P/N Y0602320211
16	0207108000	SELF-LOCKING NUT	3	
17	M1331400504	EXHAUST HEAT SHIELD (A)	1	
18	M1331400904	EXHAUST HEAT SHIELD (B)	1	
19	M1331401004	EXHAUST HEAT SHIELD (C)	1	
20	Y0272100270	HEAT SHIELD TAPE	2	
21	Y0602325051	METAL CABLE TIE	7	
22	M1334300504	FLANGE.....	1.....	S/N 8720361 AND ABOVE
23	011008020	HEX HEAD BOLT.....	4.....	S/N 8720361 AND ABOVE

# FUEL TANK ASSY.

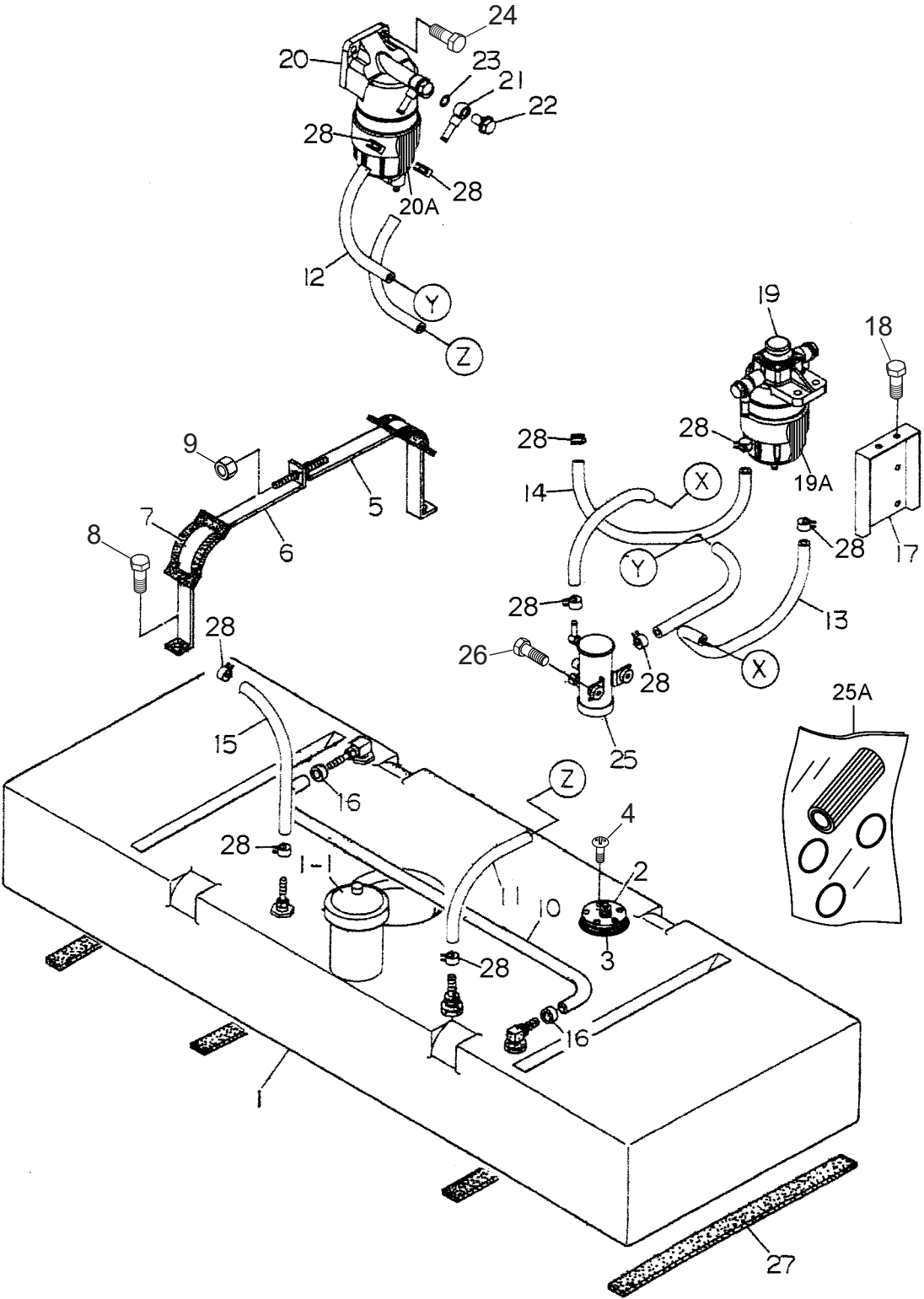

## FUEL TANK ASSY.

<u>NO.</u>	<u>PART NO.</u>	<u>PART NAME</u>	<u>QTY.</u>	<u>REMARKS</u>
1	M1364000302	FUEL TANK .....	1.....	INCLUDES ITEMS W/#
1-1#	0605505070	CAP, FUEL TANK	1	
2	Y0605501055	FUEL SENDER UNIT .....	1.....	REPLACES P/N 0605501071 S/N 8720745 AND BELOW
2	Y0605501044	FUEL SENDER UNIT.....	1.....	S/N 8720746 AND ABOVE
3	0605516090	GASKET .....	1.....	S/N 8720745 AND BELOW
3	Y0605516092	GASKET .....	1.....	S/N 8720746 AND ABOVE
4	Y0605553030	MACHINE SCREW .....	5.....	S/N 8720745 AND BELOW
4	Y0605553040	MACHINE SCREW .....	5.....	S/N 8720746 AND ABOVE
5	M1363200304	TANK BAND	2	
6	M1365200204	TANK BAND	2	
7	M9310500104	SUPPORTER SHEET	4	
8	011008020	HEX. HEAD BOLT.....	4.....	REPLACES P/N 0016908020
9	020108060	SELF-LOCKING NUT .....	4.....	REPLACES P/N 0207008000
10	0191201200	VENT HOSE	1	
11	Y0191300820	SUCTION HOSE	1	
12	Y0191300850	SUCTION HOSE	1	
13	0191301150	SUCTION HOSE	1	
14	0191300900	SUCTION HOSE	1	
15	0191301300	RETURN HOSE	1	
16	0605515189	HOSE BAND .....	2.....	S/N 8720745 AND BELOW
16	Y0605515361	HOSE CLIP.....	2.....	S/N 8720746 AND ABOVE
17	M1367700104	FUEL FILTER BRACKET	1	
18	011008020	HEX. HEAD BOLT.....	4.....	REPLACES P/N 0016908020
19	8982369900	FUEL FILTER (MAIN) .....	1.....	REPLACES P/N 0602042428
19A	8982402790	ELEMENT, FUEL FILTER (MAIN)	1	
20	8982369910	FUEL FILTER (PRE.) .....	1.....	REPLACES P/N 0602042429
20A	8982402800	ELEMENT, FUEL FILTER (PRE)	1	
21	8981263320	JOINT PIPE .....	4.....	REPLACES P/N Y0602042623
22	1096751930	EYE BOLT .....	4.....	REPLACES P/N Y0602042624
23	1096300850	PACKING .....	8.....	REPLACES P/N 0602021700
24	Y0017110035	HEX. HEAD BOLT	4	
25	8980682750	FUEL FEED PUMP .....	1.....	REPLACES P/N 0602023240
25A	8981731650	KIT, FEED PUMP, FILTER	1	
26	Y0016906025	HEX. HEAD BOLT	2	
27	Y0222100550	RUBBER SEAL	4	
28	Y0605515340	HOSE BAND .....	10.....	S/N 8720745 AND BELOW
28	Y0605515361	HOSE CLIP.....	10.....	S/N 8720746 AND ABOVE

# BATTERY CHARGER ASSY.

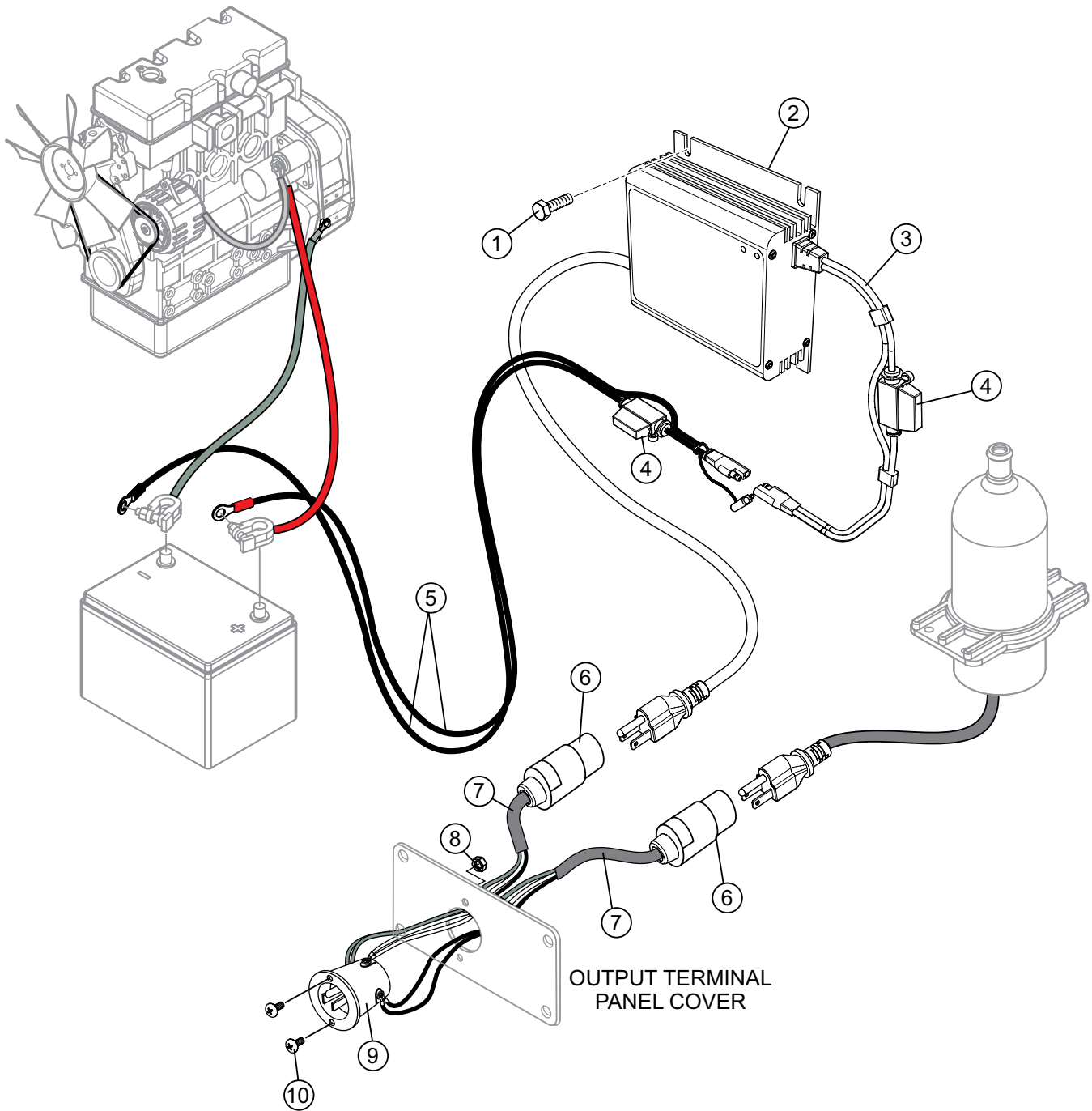

## BATTERY CHARGER ASSY.

---

<u>NO.</u>	<u>PART NO.</u>	<u>PART NAME</u>	<u>QTY.</u>	<u>REMARKS</u>
1		SCREW, 10-24 X 1/2" .....	2.....	OBTAIN LOCALLY
2	LC125002	CHARGER, BATT., FLOAT TYPE, 3A, 12V .....	1.....	INCLUDES ITEMS W/\$
3\$	EE58072	CORD, CHARGE SIDE	1	
4\$	23284-030	FUSE, 3 AMP	2	
5\$	EE58070	CORD, CHARGE, STARTER SIDE	1	
6	HBL5369C	CONNECTOR, 20 AMP, 125V	1	
7	EE56557	CORD, CAROL 3/C 14 AWG .....	AR .....	1PC = 1FT.
8	OEMAA8	HEX. NUT, 4MM	2	
9	HBL5278C	INLET FLANGE, NEMA 15A 125V	1	
10	7538070	SCREW, PHILLIPS HD.	2	

# JACKET WATER HEATER ASSY.

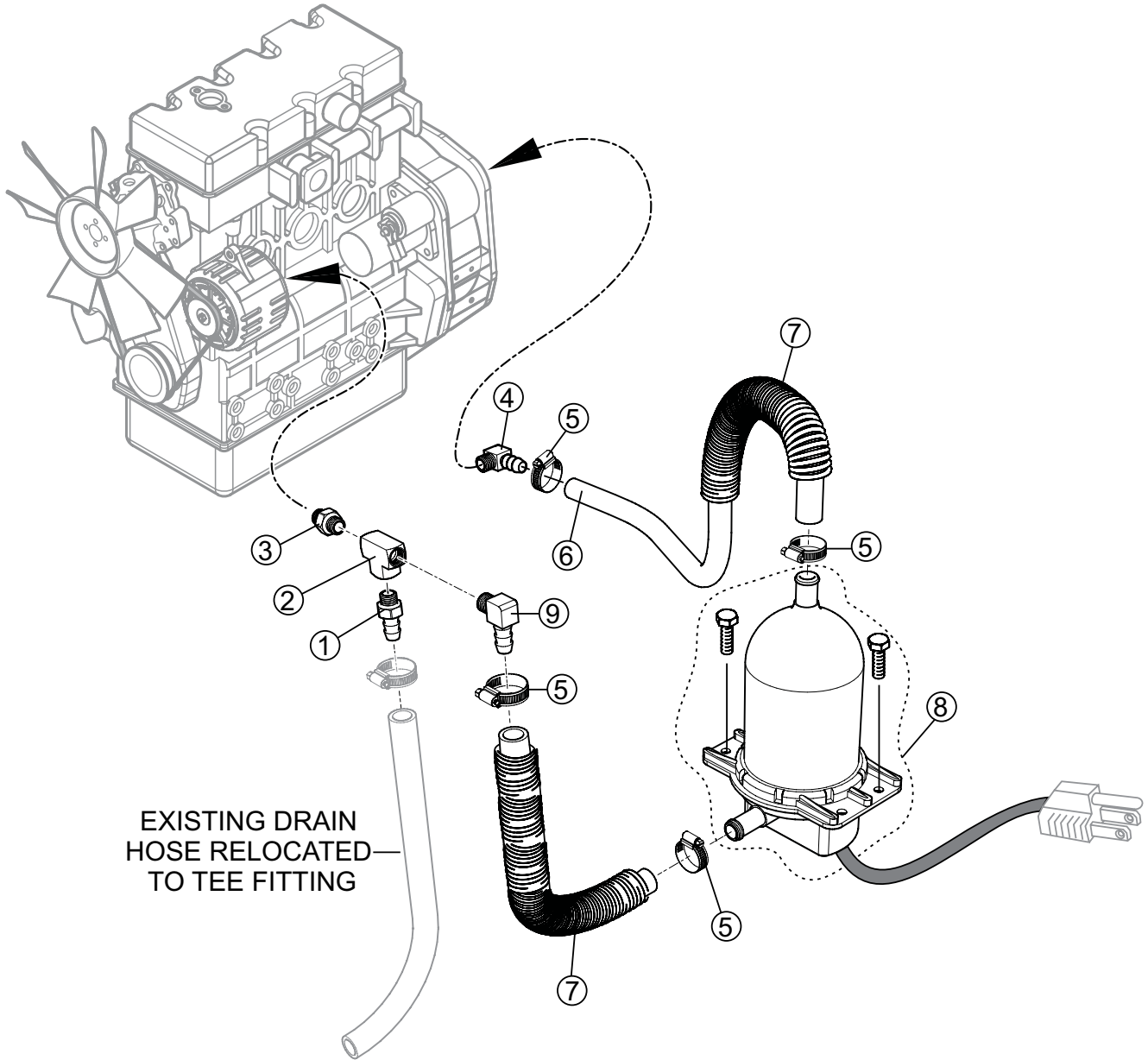

## **JACKET WATER HEATER ASSY.**

---

<u>NO.</u>	<u>PART NO.</u>	<u>PART NAME</u>	<u>QTY.</u>	<u>REMARKS</u>
1		1/4" MP X 5/16 HB NIPPLE.....	1 .....	OBTAIN LOCALLY
2		1/4 X 1/4 1/4" FEMALE PIPE TEE .....	1 .....	OBTAIN LOCALLY
3		1/4 X 1/4 MALE TO MALE PIPE NIPPLE....	1 .....	OBTAIN LOCALLY
4		3/8" MP X 5/8 HB 90° ELBOW.....	1 .....	OBTAIN LOCALLY
5		HOSE CLAMP #10 .....	4 .....	OBTAIN LOCALLY
6		HEATER HOSE, 5/8" ID X 30" LONG .....	1 .....	OBTAIN LOCALLY
7		SPLIT LOOM, 1 " X 20" .....	2 .....	OBTAIN LOCALLY
8	TPS051GT10000	HEATER, 500W, 120 VAC	1	
9		1/4" MP X 5/8" HB 90° ELBOW .....	1 .....	OBTAIN LOCALLY





## ENCLOSURE ASSY.

<u>NO.</u>	<u>PART NO.</u>	<u>PART NAME</u>	<u>QTY.</u>	<u>REMARKS</u>
1	M1414000512	BASE	1	
2	M1414800503	ENVIRONMENTAL TANK	1	
3	0016910030	HEX. HEAD BOLT	6	
4	0603306797	SQUARE HEAD PIPE PLUG 1-1/2"	1	
5	Y0603306793	SQUARE HEAD PIPE PLUG 1/2" .....	1	S/N 8720505 AND BELOW
6	M1424000612	FRONT FRAME	1	
6A	M1494101703	ACOUSTIC SHEET	1	
6B	M1494105304	ACOUSTIC SHEET	1	
7	0016908020	HEX. HEAD BOLT .....	4	REPLACES P/N 0016908020
8	M1424200903	COVER, FRONT FRAME .....	1	REPLACES P/N 0207006000
8A	M1494101804	ACOUSTIC SHEET	1	
9	0019208020	HEX. HEAD BOLT	11	
10	0601850239	GROMMET	1	
11	M1311200004	RADIATOR BRACKET	1	
12	M1311200104	RADIATOR BRACKET	1	
13	M1311200204	RADIATOR BRACKET	2	
14	011008020	HEX. HEAD BOLT .....	4	REPLACES P/N 0016908020
15	M1311600203	FAN SHROUD	1	
16	M1311600303	FAN SHROUD	1	
17	011008020	HEX. HEAD BOLT .....	6	REPLACES P/N 0016908020
18	M1311300103	FAN GUARD	1	
19	M1311300203	FAN GUARD	1	
20	011008020	HEX. HEAD BOLT .....	6	REPLACES P/N 0016908020
21	M1434000003	CENTER FRAME .....	1	S/N 8720455 AND BELOW
21	M1434000013	CENTER FRAME .....	1	S/N 8720456 AND ABOVE
22	M1434000103	CENTER FRAME	1	
23	0012312030	HEX. HEAD BOLT .....	4	REPLACES P/N 0013612030
23A	0040012000	WASHER, LOCK	4	
23B	031112230	WASHER, FLAT .....	4	REPLACES P/N 0041212000
24	M1484500104	FUEL LEAK SWITCH BRACKET .....	1	S/N 8720455 AND BELOW
25	011206020	HEX. HEAD BOLT .....	2	REPLACES P/N 0016906020 S/N 8720455 AND BELOW
26	0605503066	FUEL LEAK DETECTED SWITCH	1	
27	0012312030	HEX. HEAD BOLT .....	4	REPLACES P/N 0013612030
27A	0040012000	WASHER, LOCK	4	
27B	031112230	WASHER, FLAT .....	4	REPLACES P/N 0041212000
28	M1444000202	REAR FRAME .....	1	S/N 8720595 AND BELOW
28	M1444000212	REAR FRAME .....	1	S/N 8720596 AND ABOVE
29	011008020	HEX. HEAD BOLT .....	4	REPLACES P/N 0016908020
30	M1444300103	REAR COVER	1	
31	M1444800303	DUCT, REAR COVER	1	
31A	M1494301103	ACOUSTIC SHEET	1	
32	0176060030	SELF-LOCKING NUT .....	5	REPLACES P/N 0207006000
33	0019208020	HEX. HEAD BOLT	7	
34	M1444200103	REAR DOOR	1	
35	M1444600104	WINDOW PLATE	1	

# ENCLOSURE ASSY. (CONT'D.)

ADD THE FOLLOWING DIGITS AFTER THE PART NUMBER WHEN ORDERING ANY PAINTED PANEL TO INDICATE COLOR OF UNIT:

- |                 |                      |
|-----------------|----------------------|
| 1-ORANGE        | 6-CATERPILLAR YELLOW |
| 2-WHITE         | 7-CATO GOLD          |
| 3-SPECTRUM GREY | 8-RED                |
| 4-SUNBELT GREEN | 9-DESERT TAN         |

THE SERIAL NUMBER MAY BE REQUIRED.

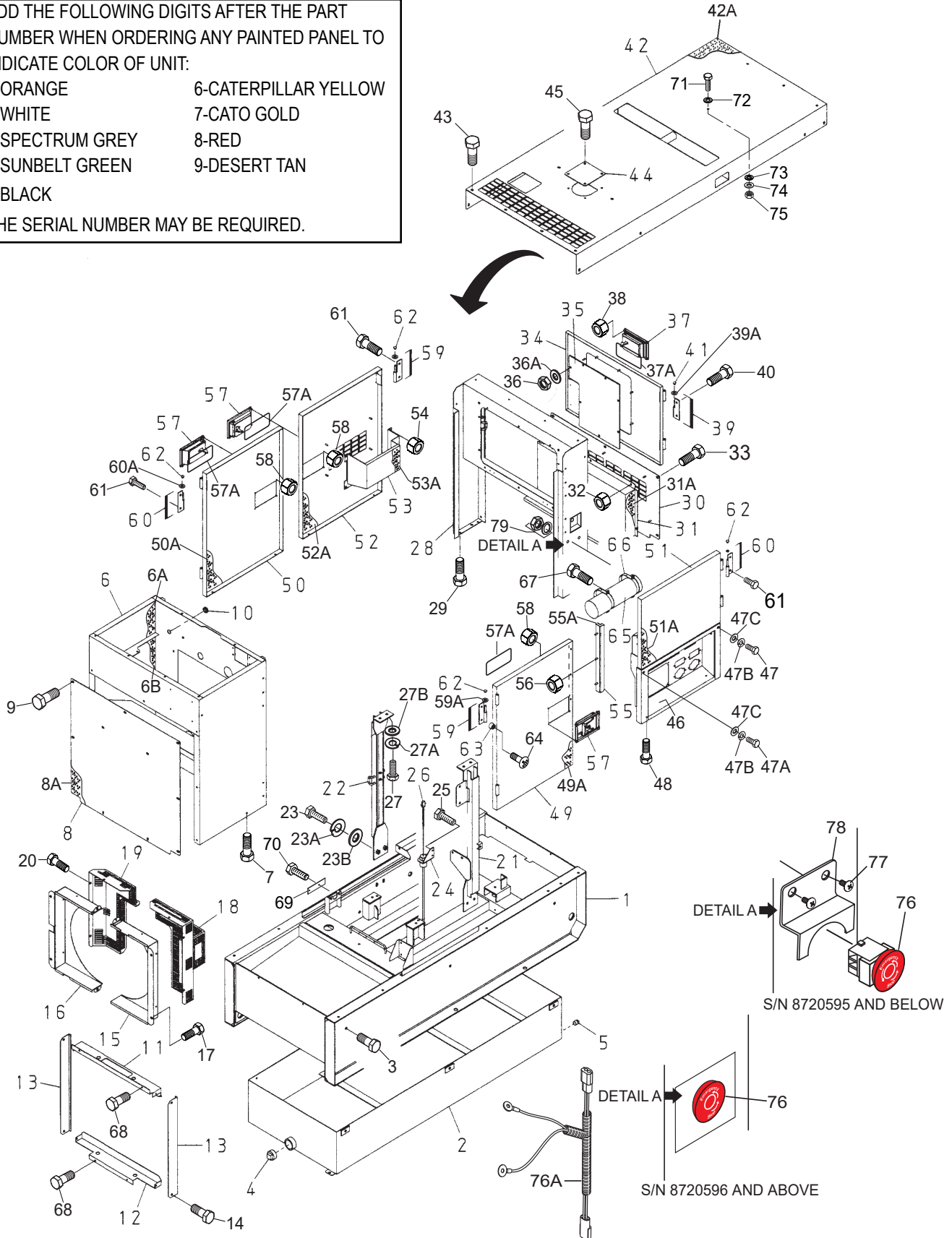

## ENCLOSURE ASSY. (CONT'D.)

<u>NO.</u>	<u>PART NO.</u>	<u>PART NAME</u>	<u>QTY.</u>	<u>REMARKS</u>
36	020106050	LOCK NUT .....	7	REPLACES P/N 0037906000
36A	952404470	WASHER, FLAT .....	7	REPLACES P/N 0041206000
37	Y0605012309	DOOR HANDLE ASSY.	1	
37A	C9312500004	SEAL RUBBER	1	
38	Y0207006000	SELF-LOCKING NUT	4	
39	M9110100204	HINGE	2	
39A	M9116100004	WASHER	2	
40	0019208020	HEX. HEAD BOLT	3	
41	0845031504	BLIND PLUG.....	2	REPLACES P/N M9310000004
42	M1464000102	ROOF PANEL	1	
42A	M1494500703	ACOUSTIC SHEET	1	
43	0019208020	HEX. HEAD BOLT	18	
44	M3310600004	COVER	1	
45	0019208020	HEX. HEAD BOLT	4	
46	M1454200602	SPLASHER PANEL .....	1	S/N 8720735 AND BELOW
46	M1454201602	SPLASHER PANEL .....	1	S/N 8720736 AND ABOVE
47	0019108055	HEX. HEAD BOLT	1	
47A	Y0019108035	HEX. HEAD BOLT	1	
47B	0042308000	WASHER, LOCK	2	
47C	031108160	WASHER, FLAT .....	2	REPLACES P/N 0042408000
48	011008020	HEX. HEAD BOLT.....	2	REPLACES P/N 0016908020
49	M1454000603	SIDE DOOR	1	
49A	M1494400604	ACOUSTIC SHEET	1	
50	M1454000703	SIDE DOOR	1	
50A	M1494400704	ACOUSTIC SHEET	1	
51	M1454000803	SIDE DOOR	1	
51A	M1494400804	ACOUSTIC SHEET	1	
52	M1454000903	SIDE DOOR	1	
52A	M1494400904	ACOUSTIC SHEET	1	
53	M1454300204	DUCT	1	
53A	M1494401204	ACOUSTIC SHEET	1	
54	0176060030	SELF-LOCKING NUT .....	5	REPLACES P/N 0207006000
55	M1454700004	DOOR SUPPORTER	1	
55A	Y0229200400	RUBBER SEAL	1	
56	0207006000	SELF-LOCKING NUT	3	
57	Y0605012309	DOOR HANDLE ASSY.	3	
57A	C9312500004	SEAL RUBBER	3	
58	0176060030	SELF-LOCKING NUT .....	12	REPLACES P/N 0207006000
59	M9110100204	HINGE	4	
59A	M9116100004	WASHER	4	
60	M9110100304	HINGE	4	
60A	M9116100004	WASHER	4	
61	0019208020	HEX. HEAD BOLT	9	
62	0845031504	BLIND PLUG.....	8	REPLACES P/N M9310000004
63	0601850097	DOOR STOPPER	8	
64	0027208025	MACHINE SCREW	8	
65	0600800321	MANUAL PAK	1	

# ENCLOSURE ASSY. (CONT'D.)

ADD THE FOLLOWING DIGITS AFTER THE PART NUMBER WHEN ORDERING ANY PAINTED PANEL TO INDICATE COLOR OF UNIT:

- |                 |                      |
|-----------------|----------------------|
| 1-ORANGE        | 6-CATERPILLAR YELLOW |
| 2-WHITE         | 7-CATO GOLD          |
| 3-SPECTRUM GREY | 8-RED                |
| 4-SUNBELT GREEN | 9-DESERT TAN         |
| 5-BLACK         |                      |
- THE SERIAL NUMBER MAY BE REQUIRED.

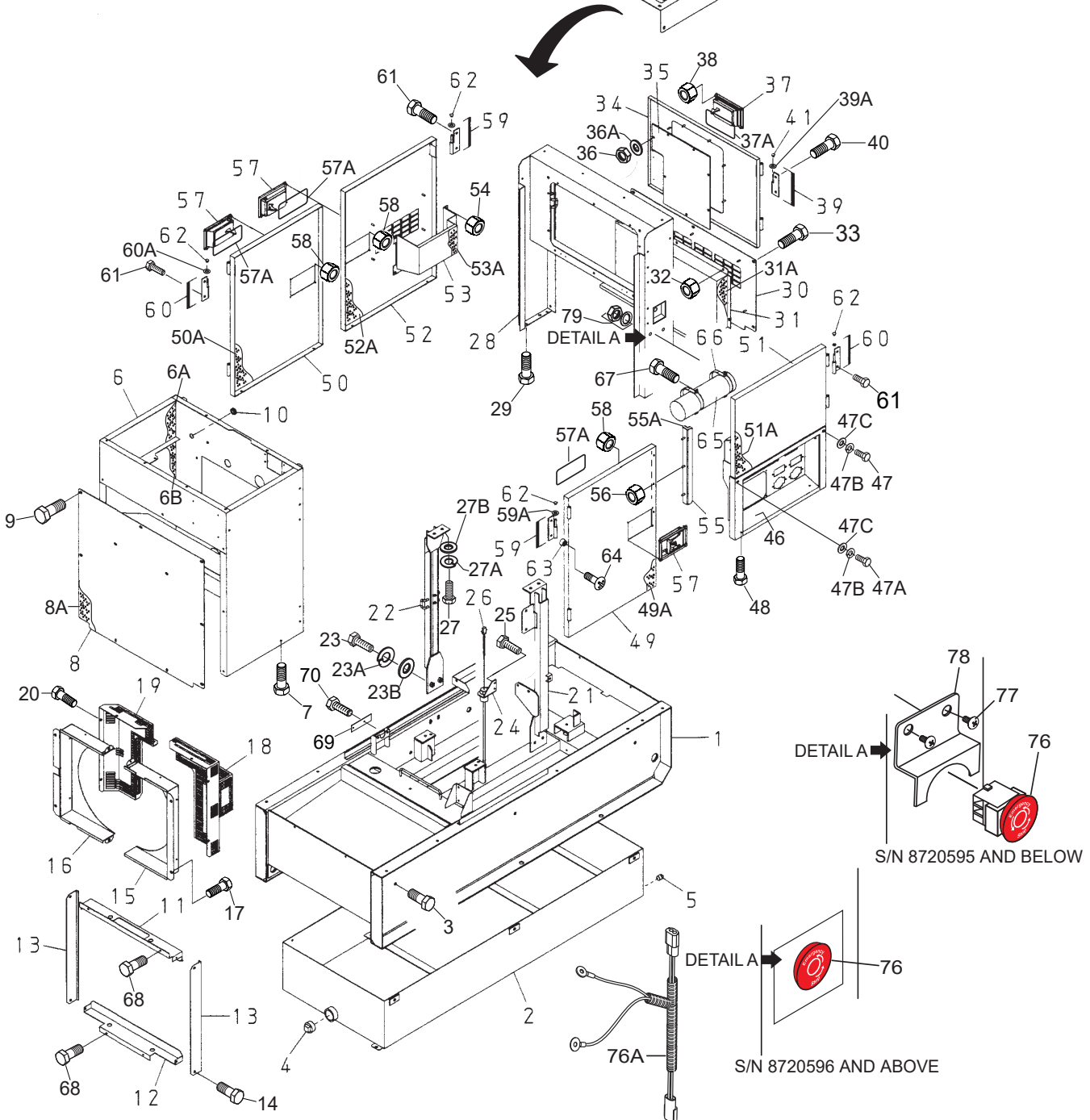
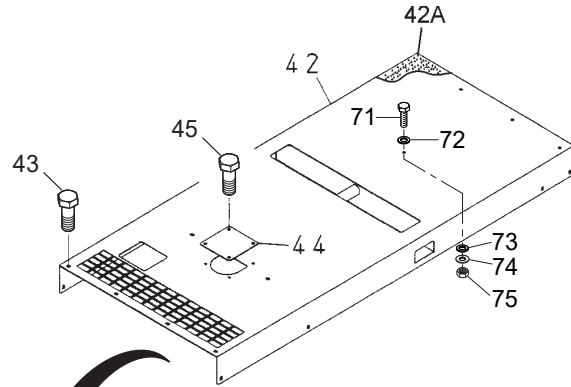

## ENCLOSURE ASSY. (CONT'D.)

<u>NO.</u>	<u>PART NO.</u>	<u>PART NAME</u>	<u>QTY.</u>	<u>REMARKS</u>
66	M1483600804	CLAMPER, MANUAL-PAK	2	
67	011106015	HEX. HEAD BOLT .....	4	REPLACES P/N 0016906015
68	011008020	HEX. HEAD BOLT .....	4	REPLACES P/N 0016908020
69	M2414800304	HOLE COVER (BASE) .....	1	S/N 8720496 AND ABOVE
70	011008020	HEX. HEAD BOLT.....	2	REPLACES P/N 0016908020 S/N 8720496 AND ABOVE
71	0019112030	HEX. HEAD BOLT.....	1	S/N 8720576 AND ABOVE
72	Y0605050040	SEALING WASHER.....	1	S/N 8720576 AND ABOVE
73	0042312000	WASHER, LOCK.....	1	S/N 8720576 AND ABOVE
74	0042412000	WASHER, FLAT.....	1	S/N 8720576 AND ABOVE
75	0030012000	HEX. HEAD NUT .....	1	S/N 8720576 AND ABOVE
76	EE55989	SWITCH, EMERGENCY STOP .....	1	OPTION S/N 8720595 AND BELOW
76	Y0601831953	EMERGENCY STOP BUTTON .....	1	S/N 8720596 AND ABOVE
76A	M1358203004	WIRE HARNESS, E-STOP .....	1	S/N 8720596 ~ 8720781
77		MACHINE SCREW 10-24X1/2 .....	2	OBTAIN LOCALLY S/N 8720595 AND BELOW
78	EE1687	GUARD, EMERGENCY STOP .....	1	S/N 8720595 AND BELOW
79		NUT, 10-24 (W/ STAR WASHER).....	2	OBTAIN LOCALLY S/N 8720595 AND BELOW

# RUBBER SEALS ASSY.

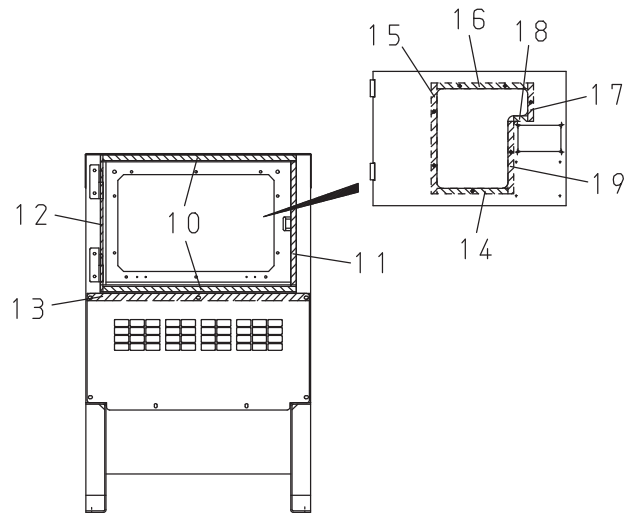
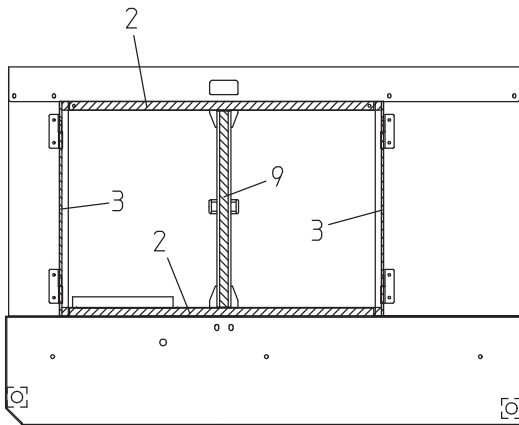
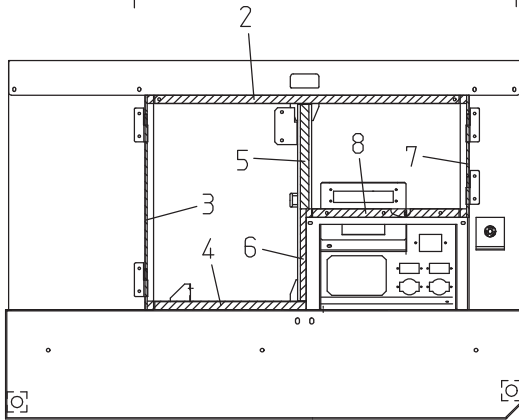
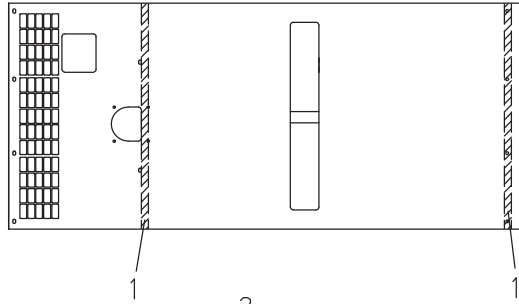

## RUBBER SEALS ASSY.

---

<u>NO.</u>	<u>PART NO.</u>	<u>PART NAME</u>	<u>QTY.</u>	<u>REMARKS</u>
1	0229200790	RUBBER SEAL	2	
2	Y0228901125	RUBBER SEAL	3	
3	0229400755	RUBBER SEAL	3	
4	0228900560	RUBBER SEAL	1	
5	0228900370	RUBBER SEAL	1	
6	0228800325	RUBBER SEAL	1	
7	0229400430	RUBBER SEAL	1	
8	0228900565	RUBBER SEAL	1	
9	0228900695	RUBBER SEAL	1	
10	0228800680	RUBBER SEAL	2	
11	Y0228800440	RUBBER SEAL	1	
12	Y0228800480	RUBBER SEAL	1	
13	0229200780	RUBBER SEAL	1	
14	Y0228100250	RUBBER SEAL	1	
15	0228100390	RUBBER SEAL	1	
16	0228100320	RUBBER SEAL	1	
17	Y0228100135	RUBBER SEAL	1	
18	Y0228100050	RUBBER SEAL	1	
19	Y0228100255	RUBBER SEAL	1	

# NAMEPLATE AND DECALS ASSY.

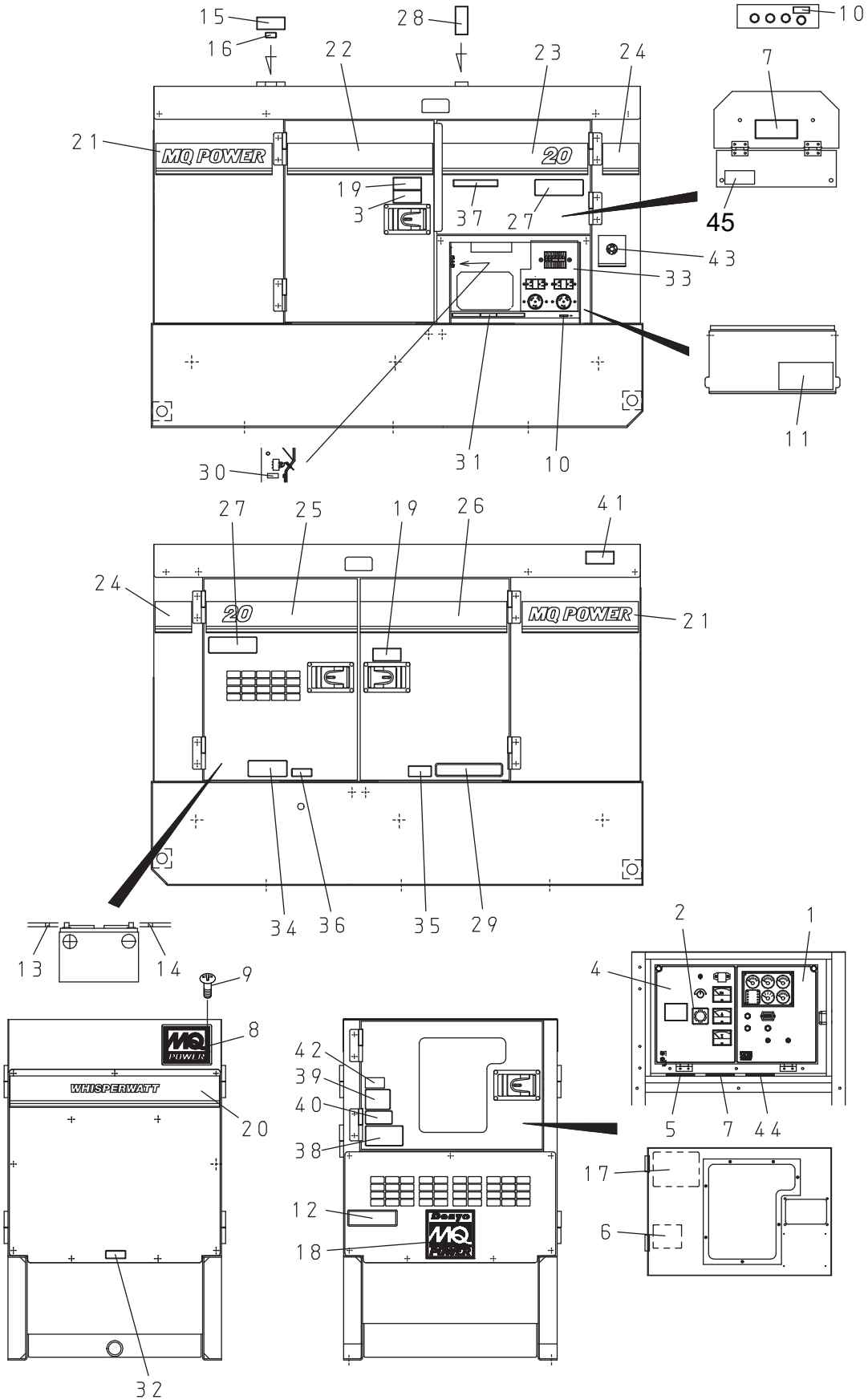



## NAMEPLATE AND DECALS ASSY.

<u>NO.</u>	<u>PART NO.</u>	<u>PART NAME</u>	<u>QTY.</u>	<u>REMARKS</u>
1	M1551000703	DECAL: ENGINE OPERATING .....	1 .....	M15100070 S/N 8720675 AND BELOW
1	M1551000713	DECAL: ENGINE OPERATING .....	1 .....	M15100071 S/N 8720676 AND ABOVE
2	M9521000504	DECAL: AMMETER CHANGE-OVER SW .....	1 .....	M92100050
3	M9510100004	DECAL: CAUTION HIGH TEMP .....	1 .....	M91010000
4	M1551000603	DECAL: GENERATOR CONTROL .....	1 .....	M15100060
5	M9520100704	DECAL: WARNING ARC FLASH .....	1 .....	M92010070
6	M9520100304	DECAL: GENERAL CAUTIONS .....	1 .....	M92010030
7	M9520100004	DECAL: WARNING ELECTRICAL SHOCK .....	2 .....	M92010000
8	0600500092	EMBLEM	1	
9	0021106015	MACHINE SCREW	4	
10	M9520000004	DECAL: GROUNDING .....	2 .....	M92000000
11	M9520100404	DECAL: DANGER, HIGH VOLTAGE .....	1 .....	M92010040
12	M9511200103	DECAL: TIER 4F .....	1 .....	M91120010
13	M9500300104	DECAL: + .....	1 .....	M90030010
14	M9500300004	DECAL: - .....	1 .....	M90030000
15	M9503100004	DECAL: WARNING FOR RADIATOR CAP .....	1 .....	M90310000
16	M9500100004	DECAL: WATER .....	1 .....	M90010000
17	M2550002303	DECAL: OPERATING PROCEDURES .....	1 .....	M25000230 S/N 8720595 AND BELOW
17	M1550001503	DECAL: OPERATING PROCEDURES .....	1 .....	S/N 8720596 AND ABOVE
18	M9511200204	STICKER, MQ .....	1 .....	M91120020
19	M9503000004	DECAL: WARNING, ROTATING PART .....	2 .....	M90300000
20	M1561100703	STRIPE 1	1	
21	M1560101604	STRIPE 2	2	
22	M1561100804	STRIPE 1	1	
23	M1561102003	STRIPE 1	1	
24	M1561101004	STRIPE 2	2	
25	M1561102103	STRIPE 1	1	
26	M1561101904	STRIPE 1	1	
27	M9520100603	DECAL: WARNING AUTO START .....	2 .....	M92010060
28	M1550001404	CAUTION: LIFTING CAPACITY .....	1 .....	M15000140
29	M9503000103	DECAL: DAILY CHECK WATER AND OIL .....	1 .....	M90300010
30	M9520000504	DECAL: START CONTACT .....	1 .....	M92000050
31	M9520100503	DECAL: WARNING, ELECTRICAL .....	1 .....	M92010050
32	M9510000004	DECAL: FLUID DRAIN .....	1 .....	M91000000
33	M1551001003	DECAL: AUXILIARY OUTPUT .....	1 .....	M15100100
34	M9510100403	DECAL: CAUTION, OFF/RESET SW .....	1 .....	M91010040
35	M9501500004	DECAL: DIESEL FUEL .....	1 .....	M90150000
36	M9500000004	DECAL: OIL DRAIN .....	1 .....	M90000000
37	M9510000104	DECAL: DOCUMENT BOX LOCATED .....	1 .....	M91000010
38	M9511100004	DECAL: WARNING ENVIRONMENTAL .....	1 .....	M91110000
39	M9503200104	DECAL: DANGER EX. GAS (INDOOR) .....	1 .....	M90320010
40	M9504200004	DECAL: WARNING START FIRES .....	1 .....	M90420000

# NAMEPLATE AND DECALS ASSY. (CONT'D.)

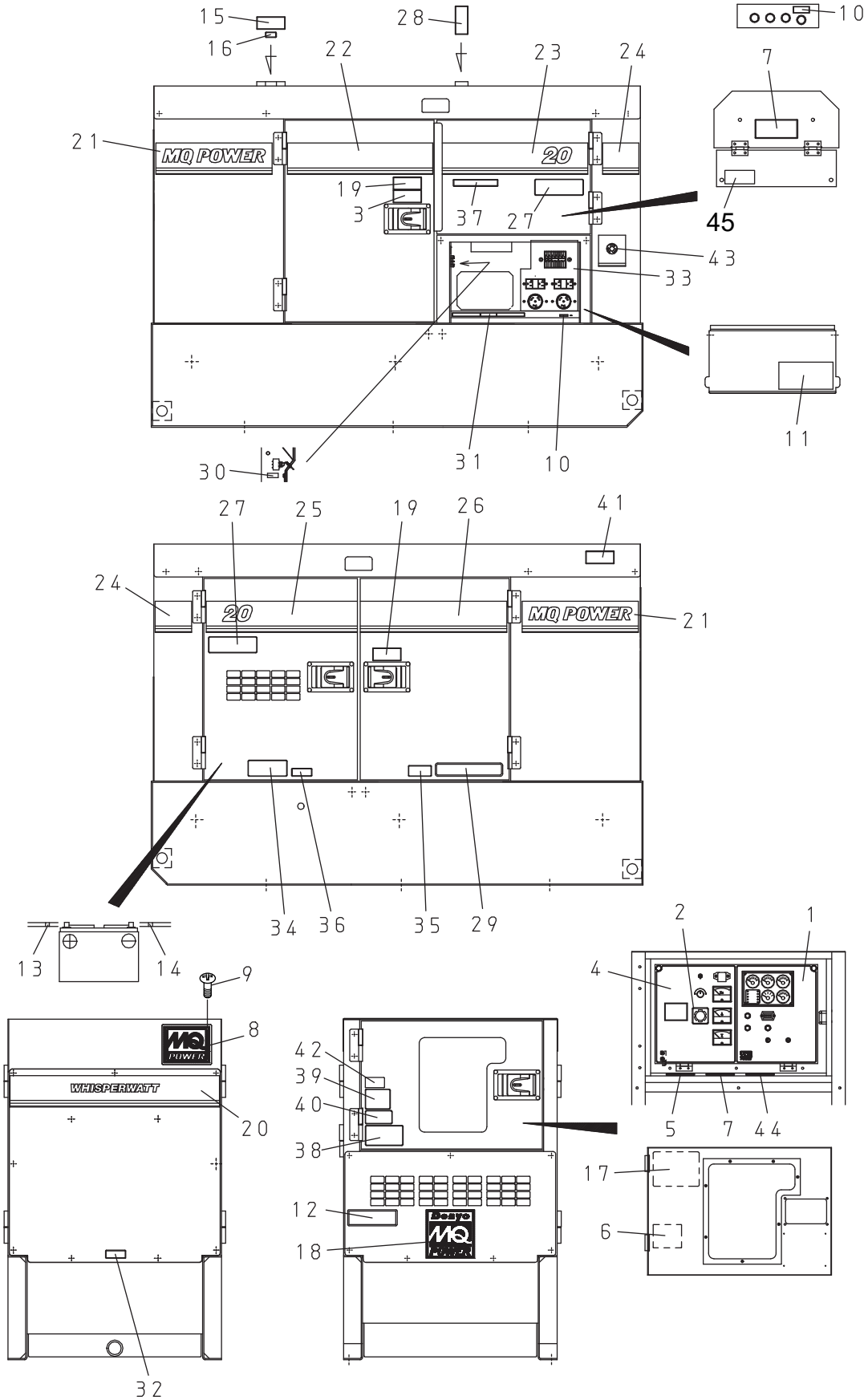

## NAMEPLATE AND DECALS ASSY. (CONT'D.)

---

<u>NO.</u>	<u>PART NO.</u>	<u>PART NAME</u>	<u>QTY.</u>	<u>REMARKS</u>
41	M9503200004	DECAL: WARNING EXHAUST GAS .....	1 .....	M90320000
42	M9504200104	DECAL: WARNING PROPOSITION 65.....	1 .....	M90420010 S/N 8720506 AND ABOVE
43	M9521002804	DECAL: EMERGENCY STOP BUTTON .....	1 .....	M92100280 S/N 8720596 AND ABOVE
44	M1551001704	NOTICE: RELEASE E-STOP .....	1 .....	M15100170 S/N 8720676 AND ABOVE
45	M1551001804	DECAL: OUTPUT TERMINAL BOLT TORQUE.....	1 .....	M15100180 S/N 8720782 AND ABOVE

# PARTS MANUAL

## HERE'S HOW TO GET HELP

PLEASE HAVE THE MODEL AND SERIAL  
NUMBER ON HAND WHEN CALLING

### UNITED STATES

#### *Multiquip Inc.*

(310) 537- 3700  
6141 Katella Avenue Suite 200  
Cypress, CA 90630  
E-MAIL: [mq@multiquip.com](mailto:mq@multiquip.com)  
WEBSITE: [www.multiquip.com](http://www.multiquip.com)

---

### CANADA

#### *Multiquip*

(450) 625-2244  
4110 Industriel Boul.  
Laval, Quebec, Canada H7L 6V3  
E-MAIL: [infocanada@multiquip.com](mailto:infocanada@multiquip.com)

### UNITED KINGDOM

#### *Multiquip (UK) Limited Head Office*

0161 339 2223  
Unit 2, Northpoint Industrial Estate, Globe Lane,  
Dukinfield, Cheshire SK16 4UJ  
E-MAIL: [sales@multiquip.co.uk](mailto:sales@multiquip.co.uk)

© COPYRIGHT 2025, MULTIQUIP INC.

Multiquip Inc., the MQ logo and the MQ Power logo are registered trademarks of Multiquip Inc. and may not be used, reproduced, or altered without written permission. All other trademarks are the property of their respective owners and used with permission.

This manual MUST accompany the equipment at all times. This manual is considered a permanent part of the equipment and should remain with the unit if resold.

The information and specifications included in this publication were in effect at the time of approval for printing. Illustrations, descriptions, references and technical data contained in this manual are for guidance only and may not be considered as binding. Multiquip Inc. reserves the right to discontinue or change specifications, design or the information published in this publication at any time without notice and without incurring any obligations.

Manufactured for  
MQ Power Inc.  
by  
DENYO MANUFACTURING CORP.

