



DCA25USI

MQ POWER Series Generator

WhisperWatt™ 25

Prime Rating — 20 kW (25 kVA)

Standby Rating — 22 kW (27.5 kVA)

60 Hertz

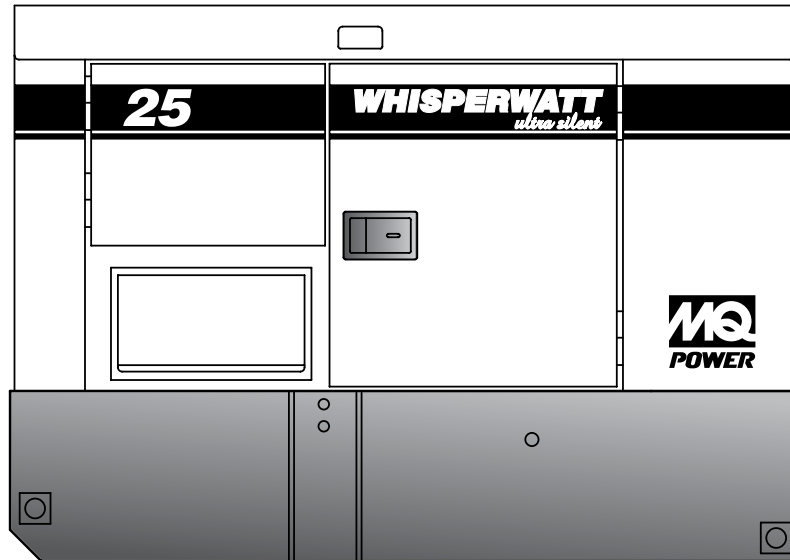

STANDARD FEATURES

- Heavy duty, 4-cycle, direct injection, diesel engine provides maximum reliability.
- Brushless alternator reduces service and maintenance requirements and meets temperature rise standards for Class F insulation systems.
- Open delta excitation design provides virtually unlimited excitation for maximum motor starting capability.
- Automatic voltage regulator (AVR) provides precise regulation.
- Full load acceptance of standby nameplate rating in one step (NFPA 110, para 5-13.2.6).
- Sound attenuated, weather resistant, steel housing provides operation at 59 dB(A) at 23 feet. Fully lockable enclosure allows safe unattended operation.
- Internal fuel tank with direct reading of fuel gauge.
- Seven stage powder coat paint system provides durability and weather protection.
- Fuel/water separator removes condensation from fuel for extended engine life. Panel mounted alarm light included.
- Complete engine analog instrumentation includes DC ammeter, oil pressure gauge, water temp. gauge, fuel level gauge, tachometer/hour meter, preheat indicator, emergency shutdown monitors, and keyed start switch.
- Complete generator analog instrumentation includes voltage regulator control, ammeter phase selector switch, voltmeter phase selector switch, AC voltmeter, AC ammeter, frequency meter, panel light, and circuit breaker.
- Automatic safety shutdown system monitors the engine oil pressure and coolant temperature. Warning lights indicate abnormal conditions.
- Complete power panel. Fully covered; three-phase terminals and single phase receptacles allow fast and convenient hookup for most applications including temporary power boxes, tools and lighting equipment. The GFCI receptacles are NEMA 5-20, and the auxiliary outputs use CS6369 twist-lock receptacles.
- Simultaneous single and three phase power.
- Voltage selector switch offers the operator a wide range of voltages that are manually selectable. Fine tuning of the output voltage can be accomplished by adjusting the voltage regulator control knob to obtain the desired voltage.
- EPA emissions certified - Interim Tier 4 emissions compliant.



DCA25USI

MQ POWER Series Generator

SPECIFICATIONS

Generator Specifications		
Design	Revolving field, self-ventilated Drip-proof, single bearing	
Armature Connection	Star with Neutral	Zig Zag
Phase	3	Single
Standby Output	22 KW (27.5 KVA)	15.3 KW
Prime Output	20 KW (25 KVA)	14.4 KW
3Ø Voltage (L-L/L-N) Voltage Selector Switch at 3Ø 240/139	208Y/120, 220Y/127, 240Y/139	N/A
3Ø Voltage (L-L/L-N) Voltage Selector Switch at 3Ø 480/277	416Y/240, 440Y/254, 480Y/277	N/A
1Ø Voltage (L-L/L-N) (Voltage Selector Switch at 1Ø 240/120)	N/A	240/120
Power Factor	0.8	1.0
Voltage Regulation (No load to full load)	±0.5%	
Generator RPM	1800	
Frequency	60 Hz	
No. of Poles	4	
Excitation	Brushless with AVR	
Frequency	60 Hz	
Frequency Regulation: No Load to Full Load	3-5% under varying loads from no load to 100% rated load	
Frequency Regulation: Steady State	±0.5% of mean value for constant loads from no load to full load.	
Insulation	Class F	
Sound Level dB(A) Full load at 23 feet	59	

Engine Specifications	
Make / Model	Isuzu / BV-4LE2
Emissions	EPA Interim Tier 4 Certified
Starting System	Electric
Design	4-cycle, water cooled, direct injection
Displacement	133.0 in ³ (2179 cc)
No. cylinders	4
Bore x Stroke (mm)	85 x 96
Gross Engine Power Output	35.9 bhp (26.8 kWm)
BMEP	100 psi (691 kPa)
Piston Speed	1134 ft./min. (5.76 m/s)
Compression Ratio	18:1
Engine Speed	1800 rpm
Overspeed Limit	2100 rpm
Oil Capacity	2.25 gallons (8.5 liters)
Battery	12V 53Ah x 1

Fuel System		
Recommended Fuel	ASTM-D975-No.1 & No.2-D	
Maximum Fuel Flow (per hour)	3.7 gallons (14.0 liters)	
Maximum Inlet Restriction (Hg)	8.66 in. (220 mm)	
Fuel Tank Capacity	41.7 gallons (158 liters)	
Fuel Consumption	gph	lph
At full load	1.66	6.3
At 3/4 load	1.21	4.6
At 1/2 load	0.85	3.2
At 1/4 load	0.58	2.2

Cooling System	
Fan Load	0.13 hp (0.1 kW)
Coolant Capacity (with radiator)	1.70 gallons (6.4 liters)
Coolant Flow Rate (per minute)	15.6 gallons (59 liters)
Heat Rejection to Coolant (per minute)	862 Btu (0.91 MJ)
Heat Rejection to Room (per minute)	209 Btu (0.22 MJ)
Maximum Coolant Friction Head	3.1 psi (21.6 kPa)
Maximum Coolant Static Head	21 feet (6.4 meters)
Ambient Temperature Rating	104°F (40°C)

Air	
Combustion Air	56 cfm (1.6 m ³ /min)
Maximum Air Cleaner Restriction	24.9 in. H ₂ O (6.2 kPa)
Alternator Cooling Air	388 cfm (11 m ³ /min)
Radiator Cooling Air	1059 cfm (30 m ³ /min)

Exhaust System	
Gas Flow (full load)	152 cfm (4.08 m ³ /min)
Gas Temperature	1004°F (570°C)
Maximum Back Pressure	28.0 in. H ₂ O (7.0 kPa)

Amperage	
Rated Voltage	Maximum Amps
1Ø 120 Volt	55.6 Amps (4 wire) 60A x 2 (Zigzag)
1Ø 240 Volt	27.8 Amps (4 wire) 60A (Zigzag)
3Ø 240 Volt	60 Amps
3Ø 480 Volt	30 Amps
Main Line Circuit Breaker Rating	60 Amps
Over Current Relay Trip Set Point 480V Mode Only	30 Amps

WARRANTY*

Isuzu Engine

12 months from date of purchase with unlimited hours or 24 months from date of purchase with 2000 hours (whichever comes first).

Generator

24 months from date of purchase or 2000 hours (whichever occurs first).

Trailer

12 months excluding normal wear items.

*Refer to the express written, one-year limited warranty sheet for additional information.

NOTICE

Generator is not intended for use in enclosed areas or where free flow of air is restricted.

Backfeed to a utility system can cause electrocution, shock and/or property damage. **DO NOT** connect to any building's electrical system except through an approved device.

Specifications are subject to change without notice.



DCA25USI

MQ POWER Series Generator

MQ POWER DECIBEL LEVELS

Our soundproof housing allows substantially lower operating noise levels than competitive designs. WhisperWatts are at home on construction sites, in residential neighborhoods, and at hospitals — just about anywhere.

- 90 — Subway / truck traffic
- 80 — Average city traffic
- 70 — Inside car at 60 mph
- 60 — Air conditioner at 20 feet
Ultra Silent at 23 feet
- 50 — Normal conversation

59.0
DECIBELS

ULTRA-SILENT FEATURES

- **Low Noise Muffler** — Large capacity low noise muffler minimizes exhaust sound.
- **Soundproof Casing** — The new design divides the cabinet into three sections, separating the engine, muffler and radiator for more efficient cooling and reduces noise from the engine and fans.
- **New Cooling System** — An advanced design uses two separate air intake systems to cool the generator. The engine fan draws air in to cool the engine and generator housing while a second electric fan directly cools the radiator. With less air being drawn into the generator through each fan, considerably less noise is produced through the top of the generator.
- **Environmental Design** — Constructed using an integrated environmental skid and fuel tank. This design fully contains fuel leakage and any liquid that might leak from the engine such as lube oil or radiator coolant. All potentially hazardous liquids are contained without contaminating the surrounding area.

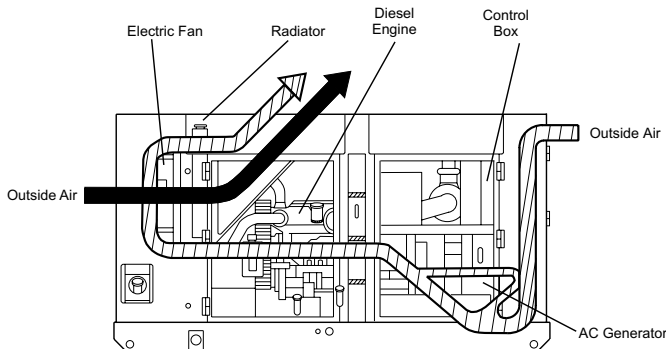

Flow of Cooling Air

GENERATOR OUTPUT PANEL

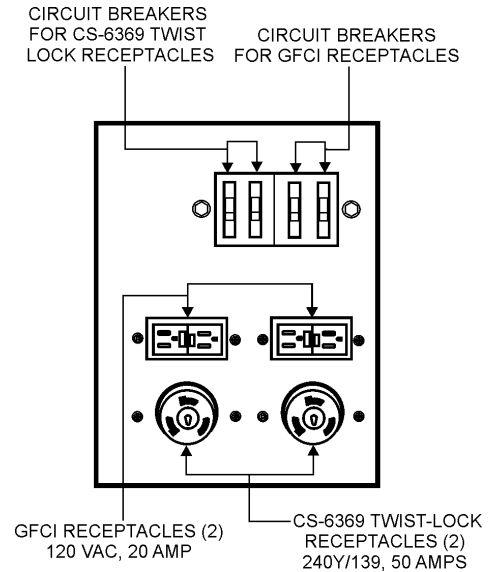

OPTIONAL CONTROL FEATURES

- **Emergency Stop Switch** — when manually activated shuts down generator in the event of an emergency.
- **Audible alarm** — alerts operator of abnormal conditions.
- **Automatic Start / Stop Control** — automatically starts the generator set during a commercial power failure when used in conjunction with a transfer switch.

OPTIONAL GENERATOR FEATURES

- **Electronic Governor Control (Crystal Sync)** — maintains frequency to within $\pm 0.25\%$ from no load to full load.
- **Battery Charger** — provides fully automatic and self-adjusting charging to the generator's battery system.
- **Jacket Water Heater** — for easy starting in cold weather climates.
- **Low Coolant Level Shutdown** — provides protection from critically low coolant levels. Includes control panel warning light.
- **Trailer Mounted Package** — meets National Highway Traffic Safety Administration (NHTSA) regulations.

OPTIONAL OUTPUT CONNECTIONS

- **Pin and Sleeve Connectors** — provides industry standard connectors for all voltage requirements.



DCA25USI

MQ POWER Series Generator

DIMENSIONS

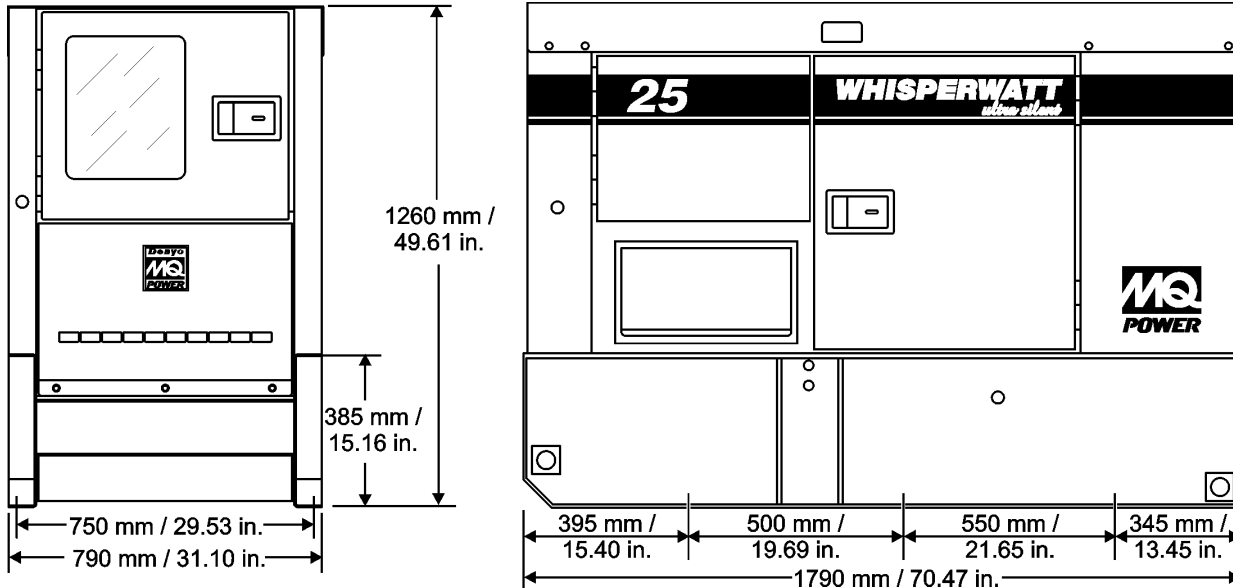

Weight	
Dry Weight	1,808 lbs. (820 kg)
Wet Weight	2,132 lbs. (967 kg)
Max. Lifting Point Capacity	6,620 lbs. (3,003 kg)

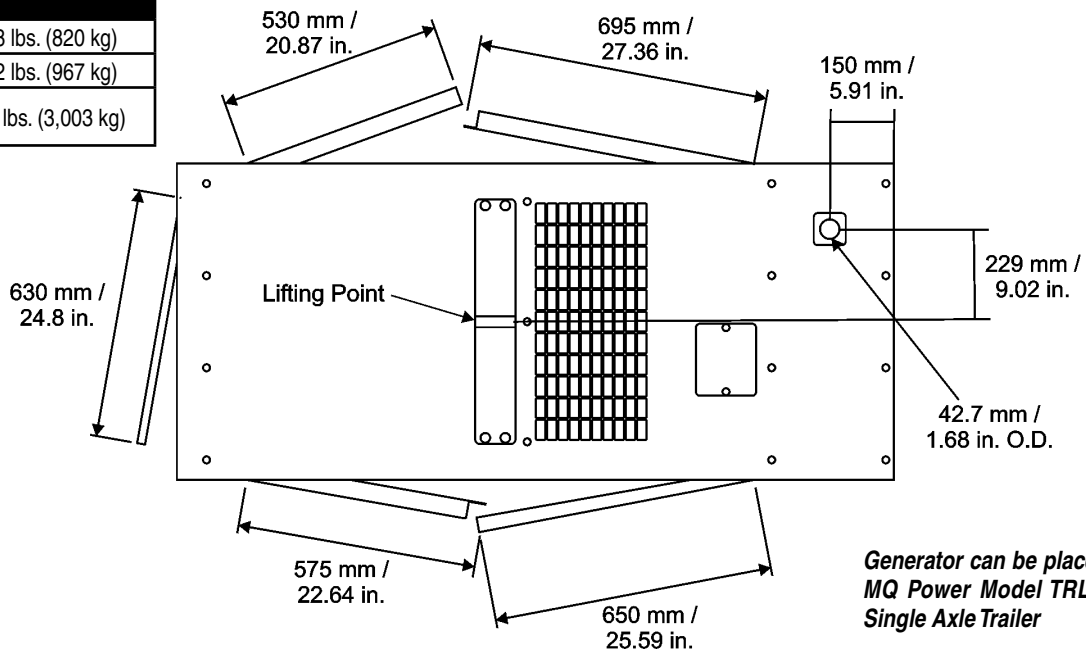

Generator can be placed on a MQ Power Model TRLR25US Single Axle Trailer

Manufactured by Denyo Co.

Your Multiquip dealer is:

