

# OPERATION MANUAL



## **WHISPERWATT™ SERIES MODEL DCA45SSIU4F 60 Hz GENERATOR (ISUZU 4LE2X DIESEL ENGINE)**

INSTRUCTION MANUAL NO. M1844300144

Revision #10 (01/23/25)

To find the latest revision of this publication or  
associated parts manual, visit our website at:  
[www.mqpower.com](http://www.mqpower.com)



**THIS MANUAL MUST ACCOMPANY THE EQUIPMENT AT ALL TIMES.**

# PROPOSITION 65 WARNING

---



# TABLE OF CONTENTS

## DCA45SSIU4F 60 Hz Generator

- Proposition 65 Warning ..... 2
- Table of Contents..... 3
- Safety Decals ..... 4
- Safety Information ..... 5–10
- Specifications ..... 11
- Dimensions..... 12
- Installation ..... 14–15
- General Information..... 16
- Major Components ..... 17
- Engine/Generator Control Panel ..... 18–19
- Output Terminal Panel Familiarization..... 20–22
- Load Application ..... 23
- PowerBalance® ..... 24
- Generator Outputs..... 25
- Gauge Reading ..... 26
- Output Terminal Panel Connections ..... 27–28
- Inspection/Setup..... 29–33
- Generator Start-Up Procedure (Manual) ..... 34–36
- Generator Start-Up Procedure (Auto Mode)..... 37
- Generator Shutdown Procedure..... 38
- Maintenance ..... 39–49
- Troubleshooting (Diagnostics)..... 50
- Troubleshooting (Generator) ..... 51
- Troubleshooting (Engine) ..... 52–53
- Generator Wiring Diagram (M18140000413) ..... 54
- Engine Wiring Diagram  
(S/N 7251795 and Below) ..... 55
- Engine Wiring Diagram  
(S/N 7251796 – 7254612) ..... 56
- Engine Wiring Diagram (M1814100433) ..... 57
- Controller Wiring Diagram (M1814100903C) ..... 58
- Battery Charger Wiring Diagram (Option) ..... 59
- Engine Block Heater Wiring Diagram (Option) ..... 60

**NOTICE**  
Specifications are subject to change without notice.



# SAFETY INFORMATION

Do not operate or service the generator before reading the entire manual. Safety precautions should be followed at all times when operating this generator. Failure to read and understand the safety messages and operating instructions could result in injury to yourself and others.







## SAFETY MESSAGES

The four safety messages shown below will inform you about potential hazards that could injure you or others. The safety messages specifically address the level of exposure to the operator and are preceded by one of four words: **DANGER**, **WARNING**, **CAUTION** or **NOTICE**.

## SAFETY SYMBOLS

 <b>DANGER</b>
Indicates a hazardous situation which, if not avoided, <b>WILL</b> result in <b>DEATH</b> or <b>SERIOUS INJURY</b> .
 <b>WARNING</b>
Indicates a hazardous situation which, if not avoided, <b>COULD</b> result in <b>DEATH</b> or <b>SERIOUS INJURY</b> .
 <b>CAUTION</b>
Indicates a hazardous situation which, if not avoided, <b>COULD</b> result in <b>MINOR</b> or <b>MODERATE INJURY</b> .
<b>NOTICE</b>
Addresses practices not related to personal injury.

Potential hazards associated with the operation of this generator will be referenced with hazard symbols which may appear throughout this manual in conjunction with safety messages.

Symbol	Safety Hazard
	Lethal exhaust gas hazards
	Explosive fuel hazards
	Burn hazards
	Overspeed hazards
	Rotating parts hazards
	Pressurized fluid hazards
	Electric shock hazards

# SAFETY INFORMATION

## GENERAL SAFETY

### ⚠ CAUTION

- **NEVER** operate this generator without proper protective clothing, shatterproof glasses, respiratory protection, hearing protection, steel-toed boots and other protective devices required by the job or city and state regulations.





- **NEVER** operate this generator when not feeling well due to fatigue or illness, or when on medication. 
- **NEVER** operate this generator under the influence of drugs or alcohol.



- **ALWAYS** check the generator for loosened threads or bolts before starting.
- **NEVER** use the generator for any purpose other than its intended purposes or applications.

### NOTICE

- This generator should only be operated by trained and qualified personnel 18 years of age and older.
- Whenever necessary, replace nameplate, operation and safety decals when they become difficult to read.
- Manufacturer does not assume responsibility for any accident due to equipment modifications. Unauthorized modification of the generator will void all warranties.
- **NEVER** use accessories or attachments that are not recommended by MQ Power for this generator. Damage to the generator and/or injury to the user may result.
- **ALWAYS** know the location of the nearest **fire extinguisher**. 
- **ALWAYS** know the location of the nearest **first aid kit**. 

- **ALWAYS** know the location of the nearest phone or **keep a phone on the job site**. Also, know the phone numbers of the nearest **ambulance, doctor, and fire department**. This information will be invaluable in the case of an emergency.



## GENERATOR SAFETY

### ⚠ DANGER

- **NEVER** operate the generator in an explosive atmosphere or near combustible materials. An explosion or fire could result causing **severe bodily harm or even death**. 

### ⚠ WARNING

- **NEVER** disconnect any **emergency or safety devices**. These devices are intended for operator safety. Disconnection of these devices can cause **severe injury, bodily harm or even death**. Disconnection of any of these devices will void all warranties.

### ⚠ CAUTION

- **NEVER** lubricate components or attempt service on a **running generator**.

### NOTICE

- **ALWAYS** ensure the generator is on level ground before use.
- **ALWAYS** keep the generator in proper running condition.
- Fix damage to the generator and replace any broken parts immediately.
- **ALWAYS** store the generator properly when it is not being used. The generator should be stored in a clean, dry location out of the reach of children and unauthorized personnel.

# SAFETY INFORMATION

## ENGINE SAFETY

### DANGER

- The engine fuel exhaust gases contain poisonous carbon monoxide. This gas is colorless and odorless, and can cause **death** if inhaled.
- The engine of this generator requires an adequate, free flow of cooling air. **NEVER** operate this equipment in any enclosed or narrow area where free flow of the air is restricted. If the air flow is restricted it will cause injury to people and property and serious damage to the equipment or engine.



- When operating the generator outdoors, **DO NOT** place the generator near doors, windows or vents that could allow carbon monoxide to enter and build up in occupied spaces.

### WARNING

- **NEVER** place hands or fingers inside the engine compartment when the engine is running.
- **NEVER** operate the engine with heat shields or guards removed.
- Keep fingers, hands, hair and clothing away from all moving parts to prevent injury.
- **NEVER** operate the generator with the doors open. Stop the engine before servicing.
- **DO NOT** remove the radiator cap while the engine is hot. High pressure boiling water will gush out of the radiator and severely scald any persons in the general area of the generator.
- **DO NOT** remove the coolant drain plug while the engine is hot. Hot coolant will gush out of the coolant tank and severely scald any persons in the general area of the generator.
- **DO NOT** drain the engine oil while the engine is hot. Hot oil will gush out and severely scald any persons near the generator.



- Operation of the generator may create sparks that can start fires around dry vegetation. A spark arrestor may be required. The operator should contact local fire agencies for laws or regulations relating to fire prevention requirements.

### CAUTION

- **NEVER** touch the hot exhaust manifold, muffler or cylinder. Allow these parts to cool before servicing the generator.



### NOTICE

- **NEVER** run the engine without an air filter or with a dirty air filter. Severe engine damage may occur. Service the air filter frequently to prevent engine malfunction.
- **NEVER** tamper with the factory settings of the engine or engine governor. Damage to the engine or generator can result if operating in speed ranges above the maximum allowable.



- Wet stacking is a common problem with diesel engines which are operated for extended periods with light or no load applied. When a diesel engine operates without sufficient load (less than 30-35% of the rated output), it will not operate at its optimum temperature. This will allow unburned fuel to accumulate in the exhaust system, which can foul the fuel injectors, engine valves and exhaust system, including turbochargers, and reduce the operating performance.

In order for a diesel engine to operate at peak efficiency, it must be able to provide fuel and air in the proper ratio and at a high enough engine temperature for the engine to completely burn all of the fuel.

Wet stacking does not usually cause any permanent damage and can be alleviated if additional load is applied to relieve the condition. It can reduce the system performance and increase maintenance. Applying an increasing load over a period of time until the excess fuel is burned off and the system capacity is reached usually can repair the condition. This can take several hours to burn off the accumulated unburned fuel.

# SAFETY INFORMATION

## FUEL SAFETY

### DANGER

- **NEVER** start the engine near spilled fuel or combustible fluids. Diesel fuel is extremely flammable and its vapors can cause an explosion if ignited.
- **ALWAYS** refuel in a well-ventilated area, away from sparks and open flames.
- **ALWAYS** use extreme caution when working with **flammable** liquids.
- **NEVER** fill the fuel tank while the engine is **running** or **hot**.
- **NEVER** overfill the fuel tank. Spilled fuel can ignite if it comes into contact with hot engine parts or sparks from the ignition system.
- Store fuel in appropriate containers, in well-ventilated areas and away from sparks and flames.
- **NEVER** use fuel as a cleaning agent.
- **NEVER** smoke around or near the equipment. Fire or explosion could result from fuel vapors or if fuel is spilled on a hot engine.



## TOWING SAFETY

### CAUTION

- Check with your local county or state safety towing regulations, in addition to meeting **Department of Transportation (DOT) Safety Towing Regulations**, before towing your generator.
- Refer to the MQ Power trailer manual for additional safety information.
- In order to reduce the possibility of an accident while transporting the generator on public roads, **ALWAYS** make sure that the trailer that supports the generator and the towing vehicle are both mechanically sound and in good operating condition.
- **ALWAYS** shut down the engine before transporting.



- Make sure the hitch and coupling of the towing vehicle are rated equal to or greater than the trailer **gross vehicle weight rating**.
- **ALWAYS** inspect the hitch and coupling for wear. **NEVER** tow a trailer with defective hitches, couplings, chains, etc.
- Check the tire air pressure on both the towing vehicle and the trailer. **Inflate trailer tires as indicated on side wall of tire**. Also check the tire tread wear on both vehicles.
- **ALWAYS** make sure the trailer is equipped with **safety chains**.
- **ALWAYS** properly attach the trailer's safety chains to the towing vehicle.
- **ALWAYS** make sure the vehicle and trailer directional, backup, brake, and trailer lights are connected and working properly.
- DOT requirements include the following:
  - Connect and test electric brake operation.
  - Secure portable power cables in cable tray with tie wraps.
- The maximum speed for highway towing is **55 MPH** unless posted otherwise. Recommended off-road towing is not to exceed **15 MPH** or less depending on the type of terrain.
- Avoid sudden stops and starts. These can cause skidding or jackknifing. Smooth, gradual starts and stops will improve towing.
- Avoid sharp turns to prevent rolling.
- The trailer should be adjusted to a level position at all times when towing.
- Raise and lock the trailer wheel stand in the upright position when towing.
- Place **chock blocks** underneath the wheels to prevent **rolling** while parked.
- Place **support blocks** underneath the trailer's bumper to prevent **tipping** while parked.
- Use the trailer's swivel jack to adjust the trailer height to a level position while parked.



# SAFETY INFORMATION

## ELECTRICAL SAFETY

### DANGER

- **NEVER** touch the output terminals during operation. Contact with the output terminals during operation can cause **electrocution, electrical shock, or burn**.



- The electrical voltage required to operate the generator can cause **severe injury or even death** through physical contact with live circuits. Turn the generator and all circuit breakers **OFF** before performing maintenance on the generator or making contact with the output terminals.

- **NEVER** insert any objects into the output receptacles during operation. This is extremely dangerous. The possibility exists of **electrical shock, electrocution or death**.



- Backfeed to a utility system can cause **electrocution** and/or property damage. **NEVER** connect the generator to a building's electrical system without a transfer switch or other approved device. All installations should be performed by a **licensed electrician** in accordance with all applicable laws and electrical codes. Failure to do so could result in electrical shock or burn, causing **serious injury or even death**.



## Power Cord/Cable Safety

### DANGER

- **NEVER** let power cords or cables **lay in water**.
- **NEVER** **stand in water** while AC power from the generator is being transferred to a load.
- **NEVER** use **damaged** or **worn** cables or cords when connecting equipment to the generator. Inspect the insulation for cuts.
- **NEVER** grab or touch a live power cord or cable with wet hands. The possibility exists of **electrical shock, electrocution or death**.

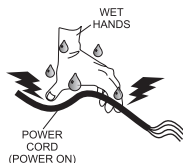

- Make sure power cables are securely connected to the generator's output receptacles. Incorrect connections may cause electrical shock and damage to the generator.

### NOTICE

- **ALWAYS** make certain that the proper power or extension cord has been selected for the job. See the Cable Selection Chart in this manual.

## Grounding Safety

### DANGER

- **ALWAYS** make sure that electrical circuits are properly grounded to a suitable earth ground (ground rod) per the National Electrical Code (NEC) and local codes before operating the generator. **Severe injury or death by electrocution** can result from operating an ungrounded generator.
- **NEVER** use gas piping as an electrical ground.

## BATTERY SAFETY

### DANGER

- **DO NOT** drop the battery. There is a possibility that the battery will explode.
- **NEVER** expose the battery to open flames, sparks, cigarettes, etc. The battery contains combustible gases and liquids. If these gases and liquids come into contact with a flame or spark, an explosion could occur.



### WARNING

- **ALWAYS** wear safety glasses when handling the battery to avoid eye irritation. The battery contains acids that can cause injury to the eyes and skin.
- Use well-insulated gloves when picking up the battery.
- **ALWAYS** keep the battery charged. If the battery is not charged, combustible gas will build up.
- **ALWAYS** recharge the battery in a well-ventilated environment to avoid the risk of a dangerous concentration of combustible gases.
- If the battery liquid (dilute sulfuric acid) comes into contact with **clothing or skin**, rinse skin or clothing immediately with plenty of water.



# SAFETY INFORMATION

- If the battery liquid (dilute sulfuric acid) comes into contact with **eyes**, rinse eyes immediately with plenty of water and contact the nearest doctor or hospital to seek medical attention.

## CAUTION

- **ALWAYS** disconnect the **NEGATIVE** battery terminal before performing service on the generator.
- **ALWAYS** keep battery cables in good working condition. Repair or replace all worn cables.

## ENVIRONMENTAL SAFETY/DECOMMISSIONING

### NOTICE

Decommissioning is a controlled process used to safely retire a piece of equipment that is no longer serviceable. If the equipment poses an unacceptable and unreparable safety risk due to wear or damage or is no longer cost effective to maintain (beyond life-cycle reliability) and is to be decommissioned (demolition and dismantlement), be sure to follow the rules below:

- **NEVER** pour waste or oil directly onto the ground, down a drain, or into any water source.
- Contact your country's Department of Public Works or recycling agency in your area and arrange for proper disposal of any electrical components, waste or oil associated with this equipment.
- When the life cycle of this equipment is over, remove the battery and bring it to an appropriate facility for lead reclamation. Use safety precautions when handling batteries that contain sulfuric acid.
- When the life cycle of this equipment is over, it is recommended that the frame and all other metal parts be sent to a recycling center.



Metal recycling involves the collection of metal from discarded products and its transformation into raw materials to use in manufacturing a new product.

Recyclers and manufacturers alike promote the process of recycling metal. Using a metal recycling center promotes energy cost savings.

## EMISSIONS INFORMATION

### NOTICE

The diesel engine used in this equipment has been designed to reduce harmful levels of carbon monoxide (CO), hydrocarbons (HC), and nitrogen oxides (NOx) contained in diesel exhaust emissions.

This engine has been certified to meet US EPA evaporative emissions requirements in the installed configuration.

Attempting to modify or make adjustments to the engine emission system by unauthorized personnel without proper training could damage the equipment or create an unsafe condition.

Additionally, modifying the fuel system may adversely affect evaporative emissions, resulting in fines or other penalties.

### Emission Control Label

The emission control label is an integral part of the emission system and is strictly controlled by regulations.

The label must remain with the engine for its entire life.

If a replacement emission label is needed, please contact your authorized engine distributor.

# SPECIFICATIONS

**Table 1. Generator Specifications**

<b>Model</b>	DCA45SSIU4F	
<b>Type</b>	Revolving field, self-ventilated, protected type synchronous generator	
<b>Armature Connection</b>	<b>Star with Neutral</b>	<b>Zigzag</b>
<b>Phase</b>	3Ø	1Ø
<b>Standby Output</b>	39.6 kW (49.5 kVA)	28.8 kW
<b>Prime Output</b>	36 kW (45 kVA)	26 kW
<b>3Ø Voltage (L-L/L-N) Voltage Selector Switch at 3Ø 240/139</b>	208Y/120, 220Y/127, 240Y/139	N/A
<b>3Ø Voltage (L-L/L-N) Voltage Selector Switch at 3Ø 480/277</b>	416Y/240, 440Y/254, 480Y/277	N/A
<b>1Ø Voltage (L-L/L-N) Voltage Selector Switch at 1Ø 240/120</b>	N/A	240/120
<b>Power Factor</b>	0.8	1.0
<b>Frequency</b>	60 Hz	
<b>Speed</b>	1,800 rpm	
<b>Aux. AC Power</b>	Single phase, 60 Hz	
<b>Subtransient</b>	0.102	
<b>Transient</b>	0.224	
<b>Synchronous</b>	2.043	
<b>Zero Sequence Reactance</b>	0.011	
<b>Overload Protection</b>	OCR/main circuit breaker	
<b>Aux. Voltage/Output</b>	120V/4.8 kW (2.4 kW × 2)	
<b>Dry Weight</b>	2,335 lb. (1,059 kg)	
<b>Wet Weight</b>	2,974 lb. (1,349 kg)	

**Table 2. Engine Specifications**

<b>Model</b>	Isuzu 4LE2X	
<b>Emission Regulation</b>	EPA Tier 4 Final	
<b>Type</b>	4-Cycle Water-cooled, direct injection, turbo-charged, air-cooled EGR	
<b>No. of Cylinders</b>	4	
<b>Bore × Stroke</b>	3.35 in. × 3.78 in. (85 mm × 96 mm)	
<b>Displacement</b>	133 cu. in. (2.17 liters)	
<b>Rated Output</b>	59 hp at 1,800 rpm	
<b>Starting</b>	Electric	
<b>Coolant Capacity (Radiator)</b>	4.44 gal. (16.8 liters) <sup>1</sup>	
<b>Lube Oil Capacity</b>	3.2 gal. (12.2 liters) <sup>2</sup>	
<b>Lubricating Type Oil</b>	API service class CJ-4 SAE or JASO DH-2	
<b>Fuel Type</b>	#2 diesel fuel (ultra low sulfur diesel fuel only)	
<b>Fuel Leak Warning Capacity</b>	21.1 gal. (80 liters)	
<b>Fuel Tank Capacity</b>	79.2 gal. (300 liters)	
<b>Fuel Consumption</b>	2.93 gal. (11.1 L)/hr. at <b>full load</b>	2.20 gal. (8.31 L)/hr. at <b>3/4 load</b>
	1.60 gal. (6.04 L)/hr. at <b>1/2 load</b>	1.04 gal. (3.92 L)/hr. at <b>1/4 load</b>
<b>Battery</b>	27 (CCA 0°F 800A) × 1	

<sup>1</sup> Includes engine and radiator hoses

<sup>2</sup> Includes filters

# DIMENSIONS

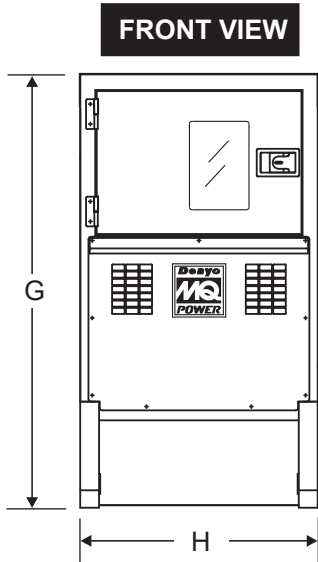
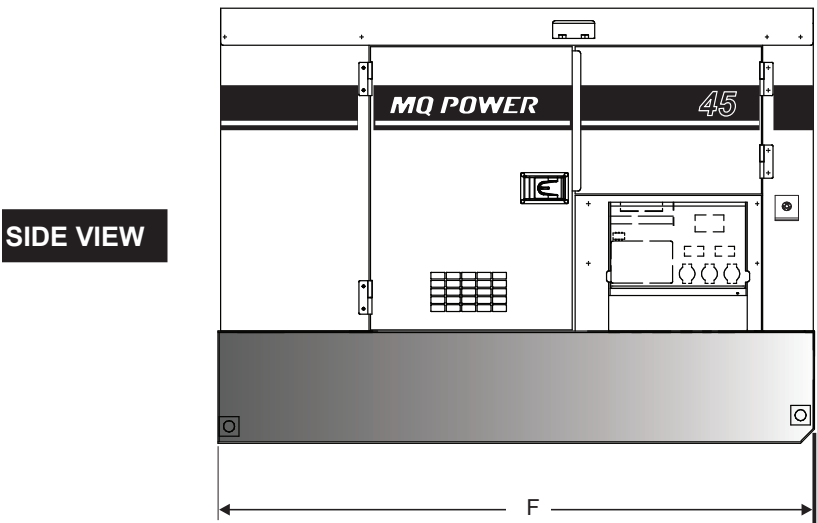
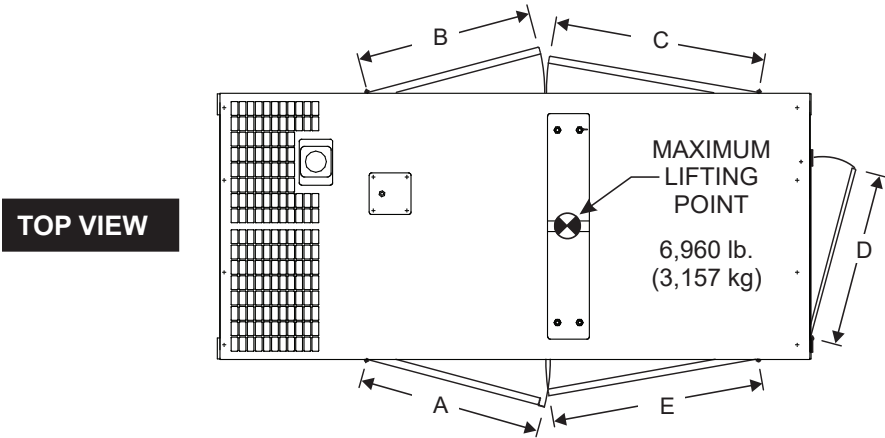

Figure 2. Dimensions

Table 3. Dimensions			
Reference Letter	Dimension in. (mm)	Reference Letter	Dimension in. (mm)
A	28.34 (720)	E	26.18 (665)
B	28.34 (720)	F	83.86 (2,130)
C	26.18 (665)	G	61.02 (1,550)
D	32.28 (820)	H	37.40 (950)



## GENERATOR GROUNDING

**ALWAYS** refer to Article 250 (Grounding and Bonding) of the National Electrical Code (NEC).

**NOTICE**  
**ALWAYS** check with state, province, district, and municipalities for electrical grounding requirements before using the generator.

## Connecting The Ground

Consult with local electrical and safety codes for proper connection based on condition of use. Refer to the Conductor Grounding Table, Article 250 of the NEC handbook.

**EXAMPLE** of how to ground the unit (Figure 3) if the condition of use requires such a device:

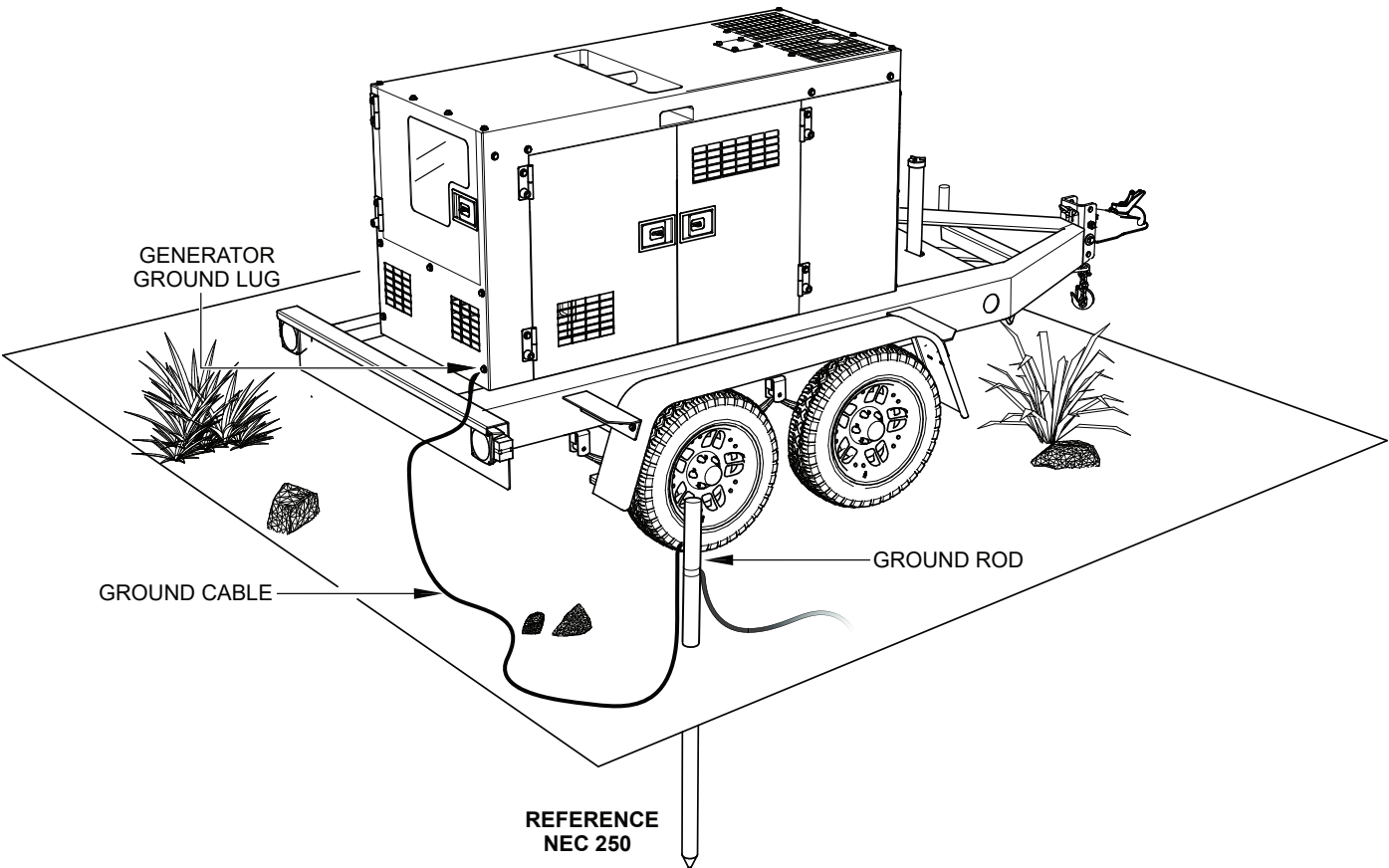

Figure 3. Typical Generator Grounding Application

**NOTICE**  
Trailer-mounted generators are the sole responsibility of MQ Power.

## OUTDOOR INSTALLATION

Install the generator in an area that is free of debris, bystanders, and overhead obstructions. Make sure the generator is on secure, level ground so that it cannot slide or shift around. Also, install the generator in a manner so that the exhaust will not be discharged in the direction of nearby homes.

The installation site must be relatively free from moisture and dust. All electrical equipment should be protected from excessive moisture. Failure to do so will result in deterioration of the insulation and will result in short circuits and grounding.

Foreign materials such as dust, sand, lint, and abrasive materials have a tendency to cause excessive wear to engine and alternator parts.

### CAUTION

Pay close attention to ventilation when operating the generator inside tunnels and caves. The engine exhaust contains noxious elements. Engine exhaust must be routed to a ventilated area.

## INDOOR INSTALLATION

Exhaust gases from diesel engines are extremely poisonous. Whenever an engine is installed indoors the exhaust fumes must be vented to the outside. The engine should be installed at least two feet from any outside wall. Using an exhaust pipe which is too long or too small can cause excessive back pressure which will cause the engine to heat excessively and possibly burn the valves.

## MOUNTING

The generator must be mounted on a solid foundation (such as concrete) and set firmly on the foundation to isolate vibration of the generator when it is running. The generator must be mounted at least 6 inches above the floor or grade level as referenced in the National Fire Protection Association handbook (NFPA 110, Chapter 7, Section 7.4).

**DO NOT** remove the metal skids on the bottom of the generator. They are to resist damage to the bottom of the generator and to maintain alignment.

## GENERATOR

This generator (Figure 4) is designed as a high-quality, portable (requires a trailer for transport) power source for telecom sites, lighting facilities, power tools, submersible pumps and other industrial and construction machinery.

## OPERATING PANEL

The “Operating Panel” is provided with the following:

- ECU Controller with Gauge Unit Assembly
  - Oil Pressure Gauge
  - Water Temperature Gauge
  - Charging Voltmeter
  - Fuel Gauge
  - Tachometer
- Panel Light/Panel Light Switch
- Pre-Heat Lamp
- Warning Lamp (Diagnostic)
- Hour Meter
- Engine Speed Switch
- Auto Start/Stop Switch
- Fuel Leak Detected Alarm Lamp

## CONTROL PANEL

The “Control Panel” is provided with the following:

- Frequency Meter (Hz)
- AC Ammeter (Amps)
- AC Voltmeter (Volts)
- Ammeter Change-Over Switch
- Voltmeter Change-Over Switch
- Voltage Regulator
- 3-Pole, 110-amp Main Circuit Breaker
- “Control Box” (located behind Control Panel)
  - Automatic Voltage Regulator
  - Current Transformer
  - Overcurrent Relay
  - Starter Relay

## OUTPUT TERMINAL PANEL

The “Output Terminal Panel” is provided with the following:

- Three 120/240V Output Receptacles (CS-6369), 50A
- Three Auxiliary Circuit Breakers, 50A
- Two 120V Output Receptacles (GFCI), 20A
- Two GFCI Circuit Breakers, 20A
- Five Output Terminal Lugs (3Ø power)
- Battery Charger (Option)
- Jacket Water Heater (Option)
- Low Coolant Switch (Option)

## OPEN-DELTA EXCITATION SYSTEM

Each generator is equipped with the state-of-the-art “Open-Delta” excitation system. The open-delta system consists of an electrically independent winding wound among stationary windings of the AC output section.

There are four connections of the open delta—A, B, C and D. During steady-state loads, the power from the voltage regulator is supplied from the parallel connections of A to B, A to D, and C to D. These three phases of the voltage input to the voltage regulator are then rectified and are the excitation current for the exciter section.

When a heavy load such as a motor starting or a short circuit occurs, the automatic voltage regulator (AVR) switches the configuration of the open delta to the series connection of B to C. This has the effect of adding the voltages of each phase to provide higher excitation to the exciter section and thus better voltage response during the application of heavy loads.

The connections of the AVR to the AC output windings are for sensing only. No power is required from these windings. The open-delta design provides virtually unlimited excitation current, offering maximum motor starting capabilities. The excitation does not have a “fixed ceiling” and responds according to the demands of the required load.

## ENGINE

This generator is powered by a 4-cylinder, 4-cycle, water-cooled, direct injection, turbocharged, EGR, DOC, Isuzu 4LE2X diesel engine. This engine is designed to meet every performance requirement for the generator. Reference Table 2 for engine specifications.

In keeping with MQ Power’s policy of constantly improving its products, the specifications quoted herein are subject to change without prior notice.

## MICROPROCESSOR CONTROL SYSTEM

The microprocessor controls the RPMs of the engine. When the engine demand increases or decreases, the microprocessor system regulates the frequency variation to  $\pm 0.25\%$ .

## EXTENSION CABLES

When electric power is to be provided to various tools or loads at some distance from the generator, extension cords are normally used. Cables should be sized to allow for distance in length and amperage so that the voltage drop between the generator and point of use (load) is held to a minimum. Use the cable selection chart (Table 6) as a guide for selecting the proper extension cable size.



# MAJOR COMPONENTS

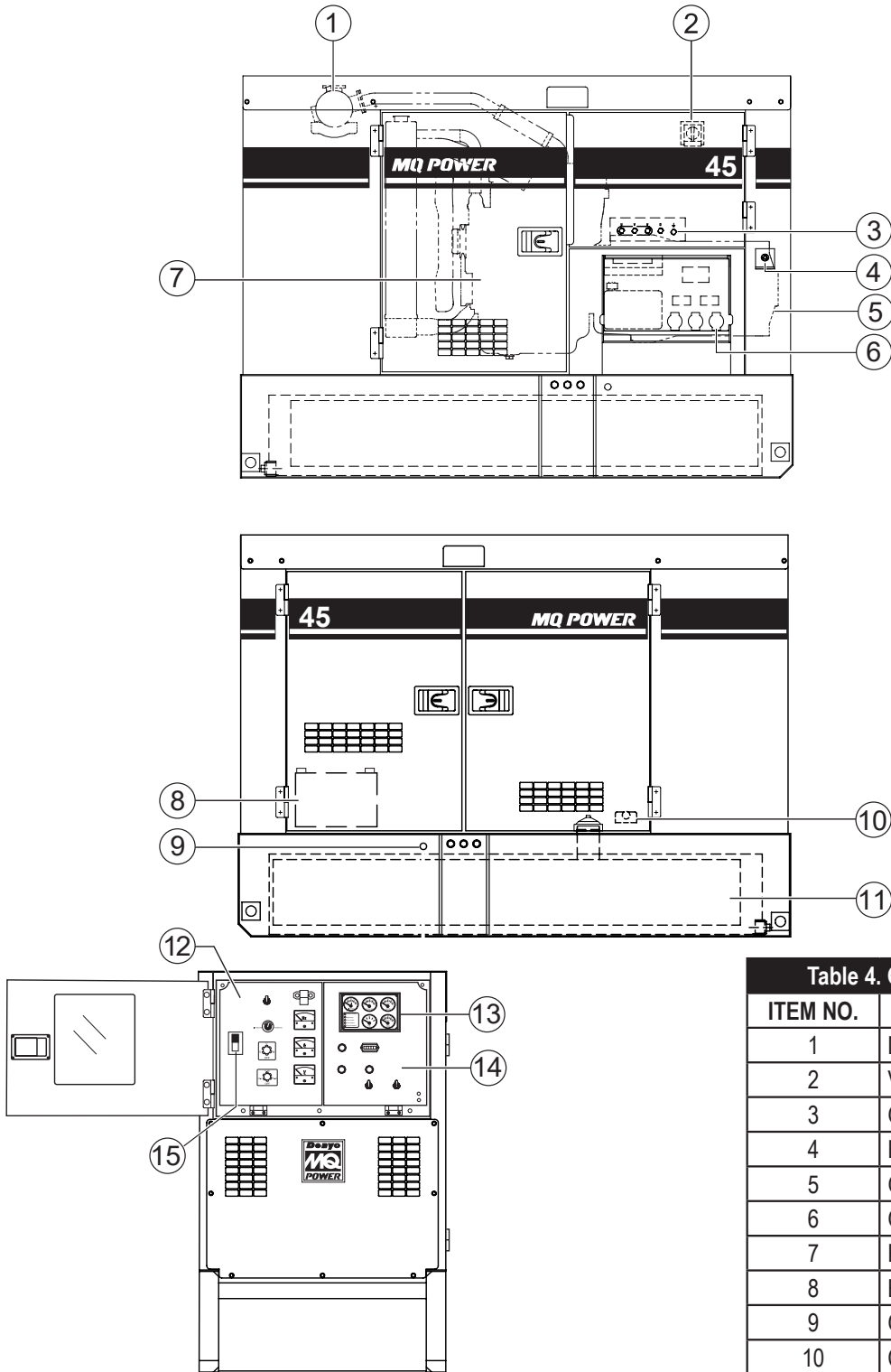

**Figure 4. Generator Major Components**

Table 4. Generator Major Components	
ITEM NO.	DESCRIPTION
1	DOC Assembly
2	Voltage Selector Switch Assembly
3	Output Terminal Assembly
4	Emergency Stop Switch
5	Generator Assembly
6	Output Receptacles Assembly
7	Engine Assembly
8	Battery Assembly
9	Oil Drain
10	Coolant Drain
11	Fuel Tank Assembly
12	Generator Control Panel Assembly
13	Controller/Gauge Unit Assembly
14	Engine Control Panel Assembly
15	Circuit Breaker

# ENGINE/GENERATOR CONTROL PANEL

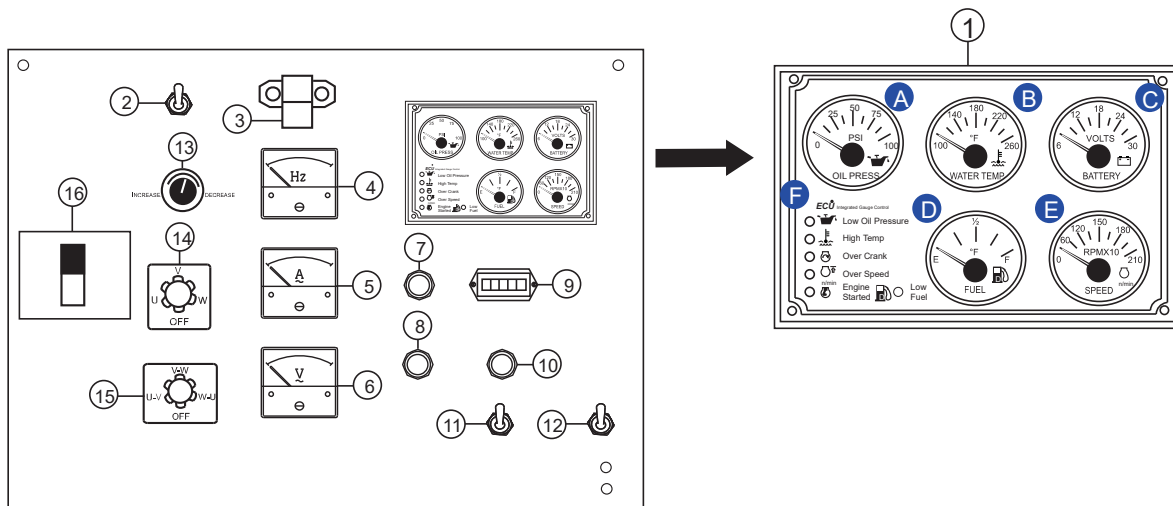

Figure 5. Engine/Generator Control Panel

The definitions below describe the controls and functions of the Engine/Generator Control Panel (Figure 5).

1. **ECU Controller with Gauge Unit Assembly** — This assembly houses the various engine monitoring gauges. These gauges indicate: oil pressure, water temperature, charging voltmeter, fuel, and engine speed RPM (tachometer).

- A. **Oil Pressure Gauge** — During normal operation this gauge should read approximately 50 psi (345 kPa). When starting the generator the oil pressure may read a little higher, but after the engine warms up the oil pressure should return to the correct pressure range.
- B. **Water Temperature Gauge** — During normal operation this gauge should indicate approximately 180°F (82°C).
- C. **Charging Voltmeter Gauge** — During normal operation this gauge should indicate minimum 14 VDC.
- D. **Fuel Gauge** — Indicates amount of diesel fuel available.
- E. **Tachometer** — Indicates engine speed in RPM for 60 Hz operation. This meter should indicate 1,800 rpm when the rated load is applied.

## F. Warning LEDs

- **Low Oil Pressure LED** — This LED will light when the engine oil pressure drops to 14.2 psi. This condition will cause the engine to shut down.
  - **High Temperature LED** — This LED will light when the coolant temperature has reached 212°F (100°C). This condition will cause the engine to shut down.
  - **Over Crank LED** — This LED will light when the engine has attempted to start 3 times and failed. The interval between the 3 start cycles is approximately 10 seconds.
  - **Over Speed LED** — This LED will light when the engine is running at an unsafe speed. This condition will cause the engine to shut down.
  - **Engine Started LED** — This LED will light when the engine has started and is operating correctly.
  - **Low Fuel LED** — When ON (lit) indicates that 20% fuel remains. Engine will shutdown with 5% fuel remaining.
2. **Panel Light Switch** — When activated will turn on the control panel light.
  3. **Panel Light** — For operation at night, the panel light illuminates the control panel for ease of reading meters and gauges. Make sure the panel light switch is in the **OFF** position when the light is not in use.

## ENGINE/GENERATOR CONTROL PANEL

---

4. **Frequency Meter** — Indicates the output frequency in hertz (Hz). Normally 60 Hz.
5. **AC Ammeter** — Indicates the amount of current the load is drawing from the generator per leg selected by the ammeter phase-selector switch.
6. **AC Voltmeter** — Indicates the output voltage present at the **U,V, and W Output Terminal Lugs**.
7. **Fuel Leak Detected Alarm Lamp** — This lamp when **ON** indicates that fluids in the containment area have reached a high level.
8. **Warning Lamp** — This lamp turns **ON** when an engine fault/failure has occurred. Reference the **Troubleshooting Diagnostic Lamp** section in this manual for fault code details.
9. **Hour Meter** — Indicates the operational hours of the generator.
10. **Pre-Heat Lamp** — When the Auto Start/Stop Switch is placed in the manual position, this lamp will illuminate to indicate preheating of the engine glow plugs. When the lamp turns off, this indicates that the preheat cycle is complete and the engine can be started.
11. **Auto Start-Stop Switch** — This switch selects either manual or automatic operation. Center position is **OFF** (reset).
12. **Engine Speed Switch** — This switch controls the speed of the engine, low or high.
13. **Voltage Regulator Control** — Allows  $\pm 15\%$  manual adjustment of the generator's output voltage.
14. **Ammeter Change-Over Switch** — This switch allows the AC ammeter to indicate the current flowing to the load connected to any phase of the output terminals, or to be switched off. This switch does not affect the generator output in any fashion, it is for current reading only.
15. **Voltmeter Change-Over Switch** — This switch allows the AC voltmeter to indicate phase-to-phase voltage between any two phases of the output terminals or to be switched off.
16. **Main Circuit Breaker** — This three-pole, 110-amp main breaker is provided to protect the **U,V, and W Output Terminal Lugs** from overload.

# OUTPUT TERMINAL PANEL FAMILIARIZATION

## OUTPUT TERMINAL PANEL

The Output Terminal Panel (Figure 6) shown below is located on the right-hand side (left from the control panel) of the generator. Lift up on the cover to gain access to receptacles and terminal lugs.

### NOTICE

**Terminal O is neutral bonded** to the ground from the factory.

### NOTICE

Output Terminal Bolt Torque: 130 lbf-in (14.7 N·m)

## OUTPUT TERMINAL FAMILIARIZATION

The “Output Terminal Panel” (Figure 6) is provided with the following:

- Three 240/120V Output Receptacles @ 50 amps
- Three Aux. Circuit Breakers @ 50 amps
- Two 120V GFCI receptacles @ 20 amps
- Two GFCI Circuit Breakers @ 20 amps
- Five Output Terminal Lugs (U, V, W, O, Ground)

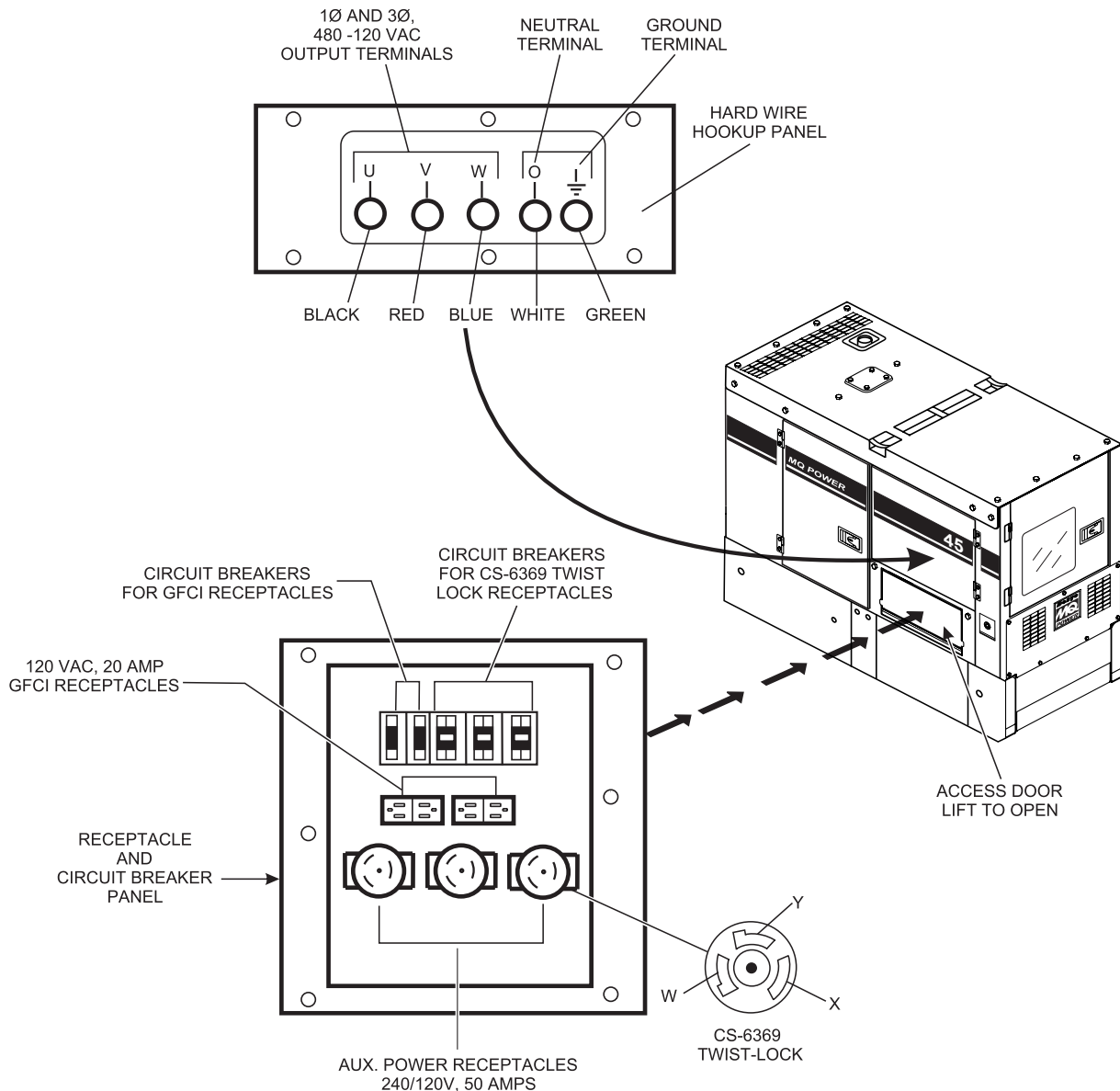

Figure 6. Output Terminal Panel

# OUTPUT TERMINAL PANEL FAMILIARIZATION

## 120 VAC GFCI Receptacles

### NOTICE

It is recommended that the GFCI receptacles be tested when the generator is initially uncrated. The receptacles should then be tested daily at startup.

There are two 120 VAC, 20-amp GFCI (Duplex NEMA 5-20R) receptacles provided on the output terminal panel. These receptacles can be accessed in any **voltage selector switch** position. Each receptacle is protected by a 20-amp circuit breaker. These breakers are located directly above the GFCI receptacles. Remember the load output (current) of both GFCI receptacles is dependent on the load requirements of the U, V, and W output terminal lugs.

Pressing the **reset** button resets the GFCI receptacle after being tripped. Pressing the **test button** (see Figure 7) in the center of the receptacle will check the GFCI function. Both receptacles should be tested at least once a month. Reference the maintenance section in this manual for further testing of the GFCI receptacle.

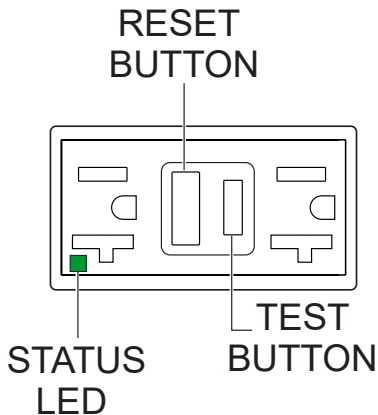

Figure 7. GFCI Receptacle

## Twist-Lock Dual-Voltage 240/120 VAC Receptacles

There are three 240/120V, 50-amp, auxiliary twist-lock (CS-6369) receptacles (Figure 8) provided on the output terminal panel. These receptacles can **only** be accessed when the voltage selector switch is placed in the **single-phase 240/120V** position.

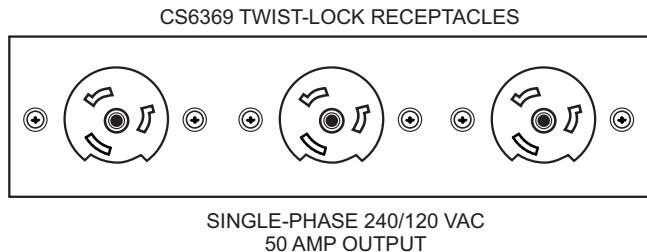

Figure 8. 240/120V Twist-Lock Auxiliary Receptacles

Each auxiliary receptacle is protected by a 50-amp circuit breaker. These breakers are located directly above the GFCI receptacles. Remember the load output (current) on both receptacles is dependent on the load requirements of the **output terminal lugs**.

## Removing The Plastic Face Plate (Hard Wire Hookup Panel)

The **output terminal lugs** are protected by a plastic face plate cover (Figure 9). Unscrew the securing bolts and lift the plastic terminal cover to gain access to the terminal enclosure.

After the load wires have been securely attached to the terminal lugs, reinstall the plastic face plate.

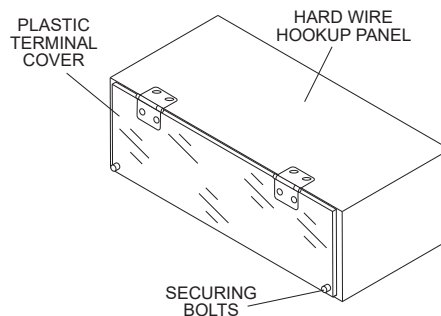

Figure 9. Plastic Face Plate (Output Terminal Lugs)

# OUTPUT TERMINAL PANEL FAMILIARIZATION

## Connecting Loads

Loads can be connected to the generator by various methods, output terminal lugs, convenience receptacles, or optional cam-locks (Figure 10). Make sure to read the operation manual before attempting to connect a load to the generator.

To protect the output terminals from overload, a 3-pole, 110-amp, **main** circuit breaker is provided. Make sure to switch **ALL** circuit breakers to the **OFF** position prior to starting the engine.

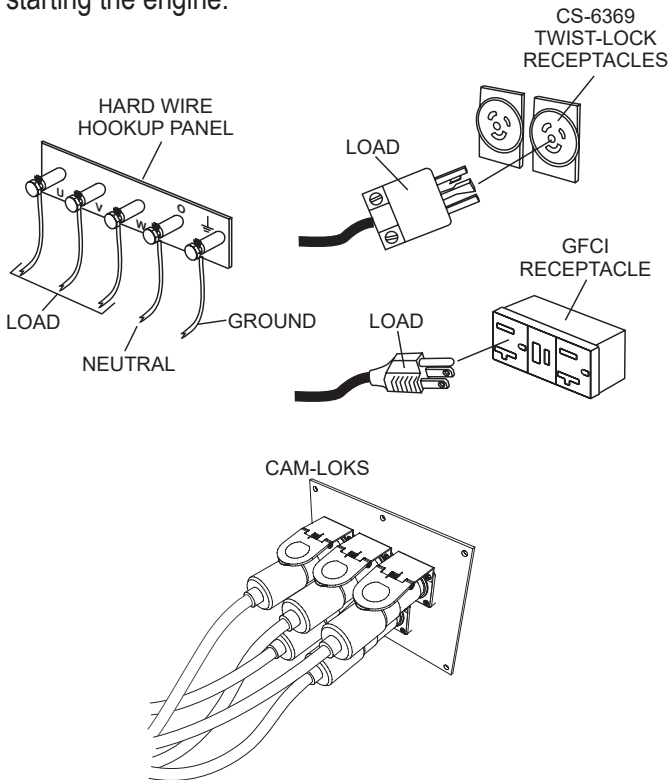

Figure 10. Connecting Loads

## Overcurrent Relay

An **overcurrent relay** (Figure 11) is connected to the main circuit breaker. In the event of an overload, both the circuit breaker and the overcurrent relay may trip. If the circuit breaker can not be reset, the **reset button** on the overcurrent relay must be pressed. The overcurrent relay is located inside the control box.

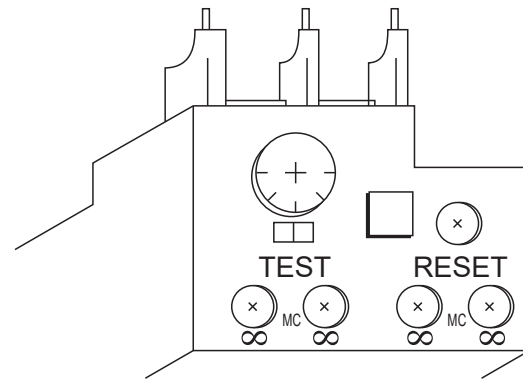

Figure 11. Overcurrent Relay

### NOTICE

Remember the **overcurrent relay** monitors the current flowing from the **U,V, and W Output Terminal Lugs** to the load.

In the event of a short circuit or overcurrent condition, it will automatically trip the 110-amp main breaker.

To restore power to the **Output Terminal Panel**, press the reset button on the overcurrent relay and place the **main** circuit breaker in the **closed** position (**ON**).

# LOAD APPLICATION

## SINGLE-PHASE LOAD

Always be sure to check the nameplate on the generator and equipment to ensure the wattage, amperage, frequency, and voltage requirements are satisfactorily supplied by the generator for operating the equipment.

Generally, the wattage listed on the nameplate of the equipment is its rated output. Equipment may require 130–150% more wattage than the rating on the nameplate, as the wattage is influenced by the efficiency, power factor and starting system of the equipment.

### NOTICE

If wattage is not given on the equipment's nameplate, approximate wattage may be determined by multiplying nameplate voltage by the nameplate amperage.

$$\text{WATTS} = \text{VOLTAGE} \times \text{AMPERAGE}$$

The power factor of this generator (single phase) is 1.0. See Table 5 below when connecting loads.

**Table 5. Power Factor By Load**

Type of Load	Power Factor
Single-phase induction motors	0.4–0.75
Electric heaters, incandescent lamps	1.0
Fluorescent lamps, mercury lamps	0.4–0.9
Electronic devices, communication equipment	1.0
Common power tools	0.8

**Table 6. Cable Selection (60 Hz, Single-Phase Operation)**

Current in Amperes	Load in Watts		Maximum Allowable Cable Length			
	At 120 Volts	At 240 Volts	#10 Wire	#12 Wire	#14 Wire	#16 Wire
2.5	300	600	1,000 ft.	600 ft.	375 ft.	250 ft.
5	600	1,200	500 ft.	300 ft.	200 ft.	125 ft.
7.5	900	1,800	350 ft.	200 ft.	125 ft.	100 ft.
10	1,200	2,400	250 ft.	150 ft.	100 ft.	
15	1,800	3,600	150 ft.	100 ft.	65 ft.	
20	2,400	4,800	125 ft.	75 ft.	50 ft.	

CAUTION: Equipment damage can result from low voltage.

### NOTICE

Cable selection table is a general guideline. **ALWAYS** consult local and national electrical codes when sizing cables.

## THREE-PHASE LOAD

When calculating the power requirements for 3-phase power use the following equation:

$$\text{KVA} = \frac{\text{VOLTAGE} \times \text{AMPERAGE} \times 1.732}{1000}$$

### NOTICE

If 3Ø load (kVA) is not given on the equipment nameplate, approximate 3Ø load may be determined by multiplying voltage by amperage by 1.732.

### NOTICE

Motors and motor-driven equipment draw much greater current for starting than during operation.

An inadequately sized connecting cable which cannot carry the required load can cause a voltage drop which can burn out the appliance or tool and overheat the cable. See Table 6.

The power factor of this generator (3 phase) is 0.8.

- When connecting a resistance load such as an incandescent lamp or electric heater, a capacity of up to the generating set's rated output (kW) can be used.
- When connecting a fluorescent or mercury lamp, a capacity of up to the generating set's rated output (kW) multiplied by 0.6 can be used.
- When connecting an electric drill or other power tools, pay close attention to the required starting current capacity.

When connecting ordinary power tools, a capacity of up to the generating set's rated output (kW) multiplied by 0.8 can be used.

### DANGER

Before connecting this generator to any building's electrical system, a **licensed electrician** must install an **isolation (transfer) switch**. Serious damage to the building's electrical system may occur without this transfer switch.

PowerBalance® (Figure 12) is an optional load management solution that helps protect the engine generator from problems resulting from sustained low-load operations (defined as less than 30% of the generator full-load rating).

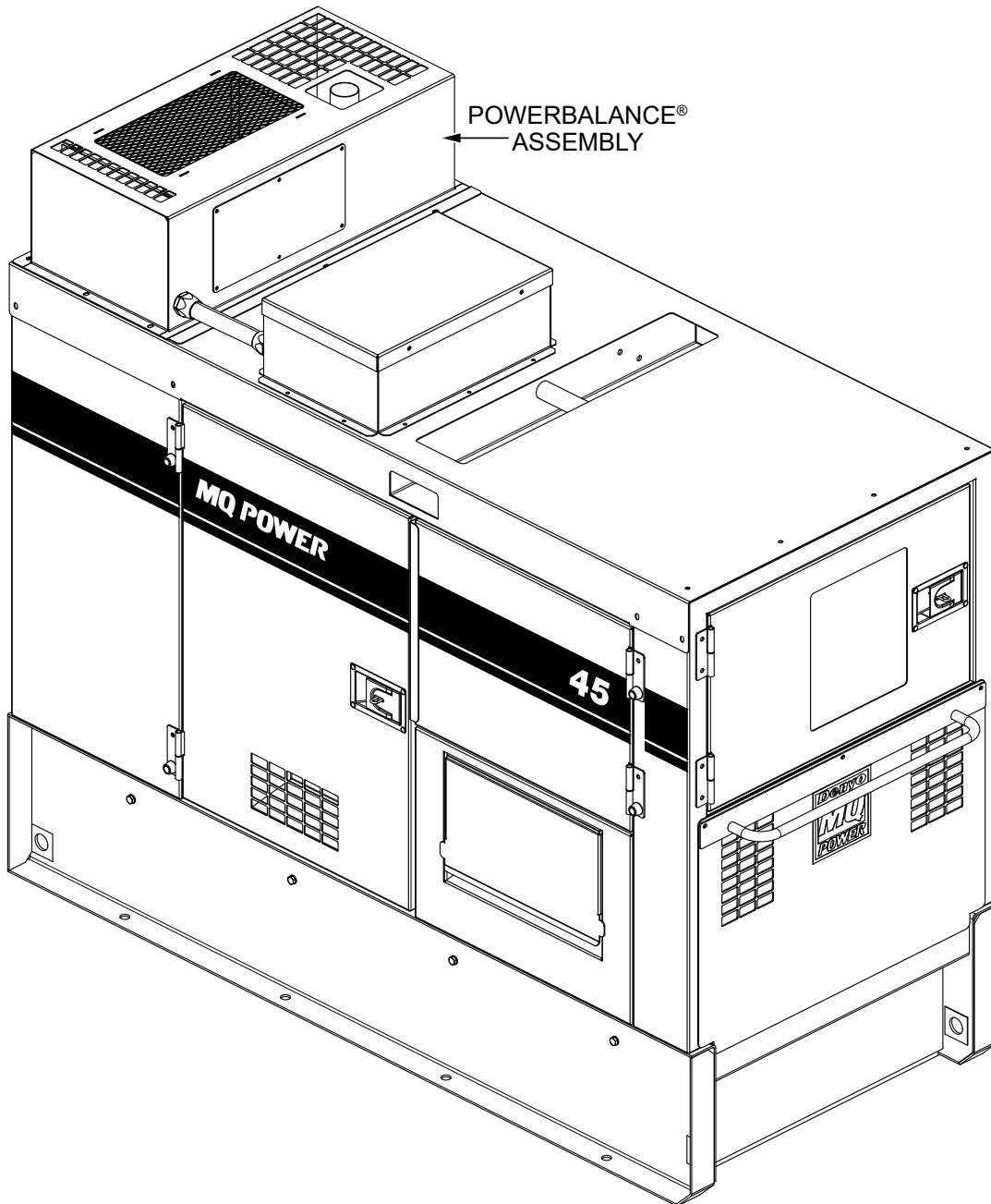

**Figure 12. PowerBalance®**

- PowerBalance® continuously monitors engine load. The load management controller senses and increases engine load automatically using resistive coils when the controller determines that the temperature and/or load is too low.
- When additional load demands are placed on the generator that bring it to an optimum level, PowerBalance® will automatically deactivate this additional load and remain ready for reactivation should exhaust temperatures drop.



# GENERATOR OUTPUTS

## GENERATOR OUTPUT VOLTAGES

A wide range of voltages (Table 7) is available for many different applications.

Table 7. Voltages Available						
UVWO Output Terminal Lugs	Voltage Selector Switch 3-Phase 240/139V Position			Voltage Selector Switch 3-Phase 480/270V Position		
	3Ø Line-Line	208V	220V	240V	416V	440V
1Ø Line-Neutral	120V	127V	139V	240V	254V	277V
Voltage Selector Switch Single-Phase 240/120V Position						
1Ø Line-Neutral/ Line-Line	120V Line-Neutral	N/A	N/A	240V Line-Line	N/A	N/A

## Voltage Selector Switch

Voltages are selected using the **Voltage Selector switch** (Figure 13) which is located above the output terminal panel's hard wire hook-up panel. This switch has been provided for ease of voltage selection.

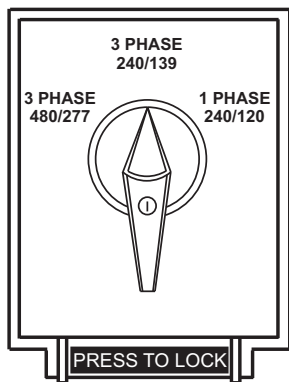

Figure 13. Voltage Selector Switch

**CAUTION**

**NEVER** change the position of the **voltage selector switch** while the engine is running. **ALWAYS** place the circuit breaker in the **OFF** position before selecting voltage.

## Voltage Regulator

To obtain some of the voltages listed in Table 7 will require a fine voltage adjustment using the **voltage regulator** (Figure 14) located on the control panel.

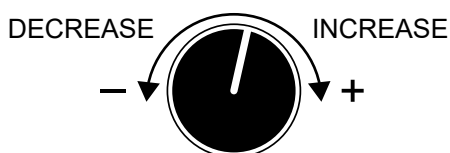

Figure 14. Voltage Regulator

## Maximum Amps

Table 8 shows the **maximum** amps the generator can provide. **DO NOT** exceed the maximum amps as listed.

Table 8. Generator Maximum Amps	
Rated Voltage	Maximum Amps
1Ø 120 volts	108 amps × 2 (zigzag)
1Ø 240 volts	108 amps (zigzag)
3Ø 240 volts	108 amps
3Ø 480 volts	54 amps
Main Line Circuit Breaker Rating	110 amps

## GFCI Receptacle Load Capability

The load capability of the GFCI receptacles is directly related to the voltage being supplied at either the output terminals or the three twist-lock auxiliary receptacles.

Table 9 and Table 10 show what amount of current is available at the GFCI receptacles when the output terminals and twist-lock receptacles are in use. Be careful that your load does not exceed the available current capability at the receptacles.

Table 9. 1Ø GFCI Receptacle Load Capacity	
kW in Use Twist Lock (CS6369)	Available Load Current (Amps)
1Ø 240/120V	GFCI Duplex 5-20R 120V
26	0
24.8	5 amps/receptacle
23.6	10 amps/receptacle
22.4	15 amps/receptacle
21.2	20 amps/receptacle

Table 10. 3Ø Generator Maximum Amps	
kVA in Use (UVWO Terminals)	Available Load Current (Amps)
3Ø 240/480V	GFCI Duplex 5-20R 120V
45	0 amps/receptacle
40.9	5 amps/receptacle
36.7	10 amps/receptacle
32.6	15 amps/receptacle
28.4	20 amps/receptacle

# GAUGE READING

## HOW TO READ THE AC AMMETER AND AC VOLTMETER GAUGES

The AC ammeter and AC voltmeter gauges are controlled by the AC ammeter and AC voltmeter change-over switches.

Both of these switches are located on the control panel and **DO NOT** affect the generator output. They are provided to help observe how much power is being produced at the UVWO terminal lugs.

Before taking a reading from either gauge, set the **Voltage Selector Switch** (Figure 15) to the position which produces the required voltage. For example, for 3Ø 240V, choose the center 3Ø 240/139V position on the voltage selector switch.

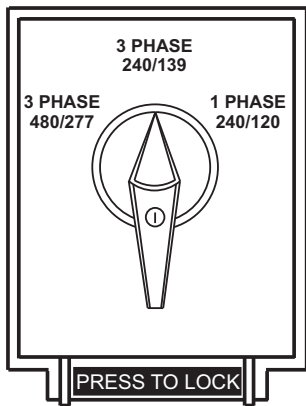

Figure 15. Voltage Selector Switch  
240V/3Ø Position

## AC Voltmeter Gauge Reading

Place the **AC Voltmeter Change-Over Switch** (Figure 16) in the W-U position and observe the phase to phase voltage reading between the W and U terminals as indicated on the **AC Voltmeter Gauge** (Figure 17).

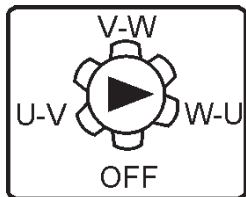

Figure 16. AC Voltmeter  
Change-Over Switch

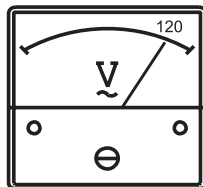

Figure 17. AC Voltmeter Gauge  
(Volt Reading On W-U Lug)

## AC Ammeter Gauge Reading

Place the **AC Ammeter Change-Over Switch** (Figure 18) in the U position and observe the current reading (load drain) on the U terminal as indicated on the **AC Ammeter Gauge** (Figure 19). This process can be repeated for terminals V and W.

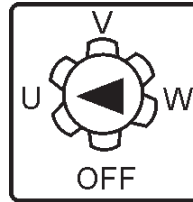

Figure 18. AC Ammeter  
Change-Over Switch

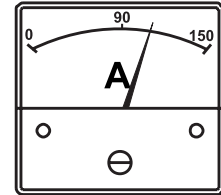

Figure 19. AC Ammeter  
(Amp Reading On U Lug)

### NOTICE

The **ammeter** gauge will only show a reading when the **Output Terminal Lugs** are connected to a load and in use.

# OUTPUT TERMINAL PANEL CONNECTIONS

## UVWO TERMINAL OUTPUT VOLTAGES

Various output voltages can be obtained using the UVWO output terminal lugs. The voltages at the terminals are dependent on the position of the **Voltage Selector Switch** and the adjustment of the **Voltage Regulator**.

Remember the voltage selector switch determines the **range** of the output voltage. The voltage regulator (VR) allows the user to increase or decrease the selected voltage.

### NOTICE

**ALWAYS** make sure that the connections to the UVWO terminals are **secure** and **tight**. The possibility exists of arcing that could cause a fire. Torque tie bolts to 130.1 lbf·in (14.7 N·m).

## 3Ø-240V UVWO Terminal Output Voltages

1. Place the voltage selector switch in the 3Ø 240/139V position as shown in Figure 20.

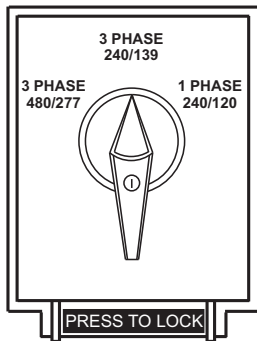

**Figure 20. Voltage Selector Switch 3Ø-240/139V Position**

2. Connect the load wires to the UVWO terminals as shown in Figure 21.

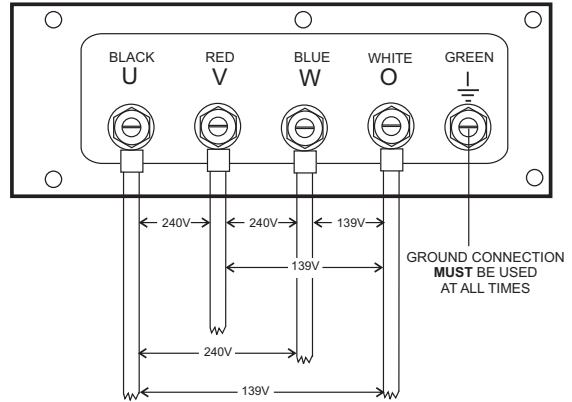

**Figure 21. UVWO Terminal Lugs (3-Phase 240-Volt Connections)**

3. Turn the voltage regulator (Figure 22) clockwise to increase voltage output, turn counterclockwise to decrease voltage output. Use the voltage regulator whenever fine tuning of the output voltage is required.



**Figure 22. Voltage Regulator**

## 3Ø-208V/1Ø-120V UVWO Terminal Output Voltages

1. Place the voltage selector switch in the 3Ø 240/139V position as shown in Figure 20.
2. Connect the load wires to the UVWO terminals as shown in Figure 23.

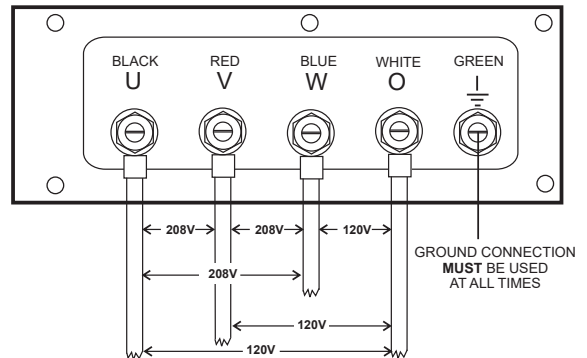

**Figure 23. UVWO Terminal Lugs 3Ø-208/1Ø-120V Connections**

# OUTPUT TERMINAL PANEL CONNECTIONS

## NOTICE

To achieve a 3Ø 208V output the voltage selector switch must be in the 3Ø-240/139 position and the voltage regulator must be adjusted to 208V.

## 3Ø-480/277V UVWO Terminal Output Voltages

1. Place the voltage selector switch in the 3Ø 480/277 position as shown in Figure 24.

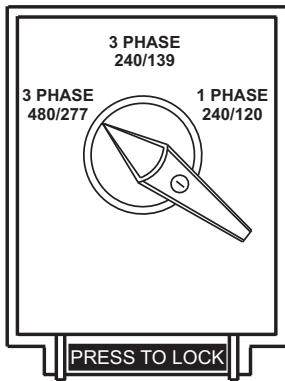

**Figure 24. Voltage Selector Switch  
3Ø-480/277V Position**

2. Connect the load wires to the UVWO terminals as shown in Figure 25.

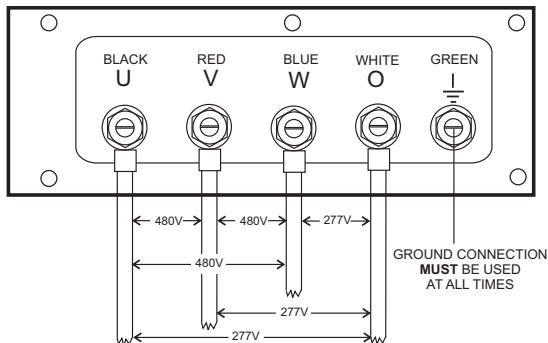

**Figure 25. UVWO Terminal Lugs 3Ø-480V  
Connections**

## 1Ø-240/120V UVWO Terminal Output Voltages

1. Place the voltage selector switch in the 1Ø 240/120 position as shown in Figure 26.

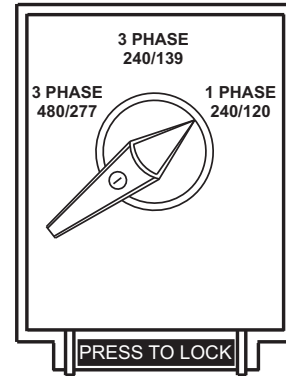

**Figure 26. Voltage Selector Switch  
1Ø-240/120V Position**

2. Connect the load wires to the UVWO terminals as shown in Figure 27.

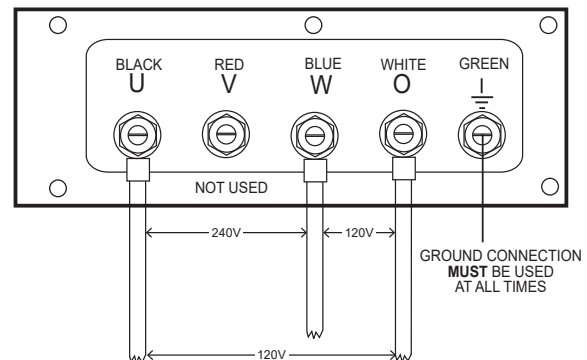
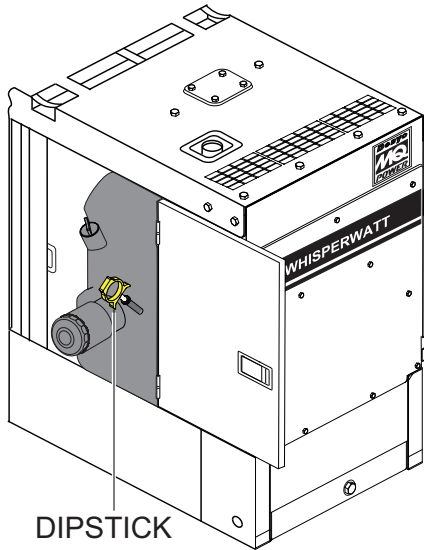

**Figure 27. UVWO Terminal Lugs  
1Ø-240/120V Connection**

3. Turn the voltage regulator (Figure 22) clockwise to increase voltage output, turn counterclockwise to decrease voltage output. Use the voltage regulator whenever fine tuning of the output voltage is required.

## ENGINE OIL CHECK

1. To check the engine oil level, place the generator on secure, level ground with the engine stopped.
2. Remove the dipstick from its holder (Figure 28) and wipe it clean.



**Figure 28. Engine Oil Dipstick**

3. Reinsert the dipstick, then remove the dipstick from its holder. Check the oil level shown on the dipstick (Figure 29).

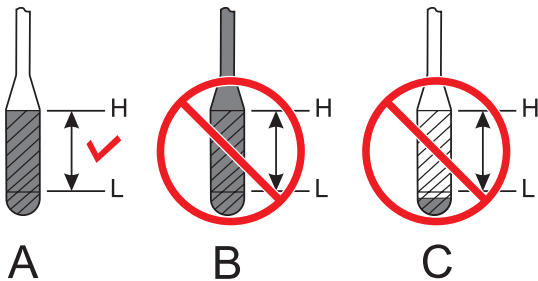
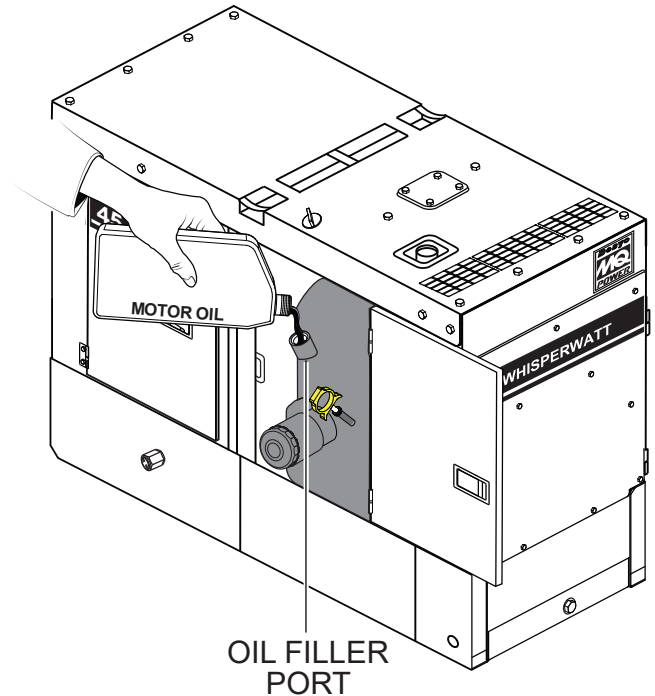

**Figure 29. Engine Oil Dipstick**

4. Verify that the engine oil level is maintained between the H and L markings on the dipstick as referenced in Figure 29A.
5. If the engine oil level is low (Figure 29C), remove the cap from the oil filler port (Figure 30) and fill to a safe operating level (max) as indicated by the dipstick (Figure 29A). Fill with recommended type oil as listed in Table 11. Maximum oil capacity is 12.8 quarts (12.2 liters).

### NOTICE

When adding engine oil **DO NOT** overfill (Figure 29B).



**Figure 30. Engine Oil Filler Port**

6. Allow enough time for any added oil to make its way to the oil pan before rechecking.
7. When checking the engine oil, be sure to check if the oil is clean. If the oil is not clean, drain the oil as referenced in the maintenance section of this manual.

**Table 11. Recommended Motor Oil**

SAE 30	
SAE 20, 20W	
SAE 10W	
SAE 10W-30	
SAE 40	
SAE 5W-40, 20W-40	
SAE 5W-20	
-20	100°F
-30	40°C
AMBIENT TEMPERATURE	

## FUEL CHECK

### DANGER



Fuel spillage on a **hot** engine can cause a **fire** or **explosion**. If fuel spillage occurs, wipe up the spilled fuel completely to prevent fire hazards. **NEVER** smoke around or near the generator. **ALWAYS** shut down the engine prior to cleaning up any spilled fuel.

## Refilling The Fuel System

### NOTICE

**DO NOT** refuel while the engine is running.

### CAUTION

**ONLY** properly trained personnel who have read and understand this section should refill the fuel tank system.

**ALWAYS** fill the fuel tank (Figure 31) with clean, fresh **#2 diesel fuel**. **DO NOT** fill the fuel tank beyond its capacity.

Pay attention to the fuel tank capacity when replenishing fuel. The fuel tank cap must be closed tightly after filling. Handle fuel in a safety container. If the container does not have a spout, use a funnel. Wipe up any spilled fuel immediately.

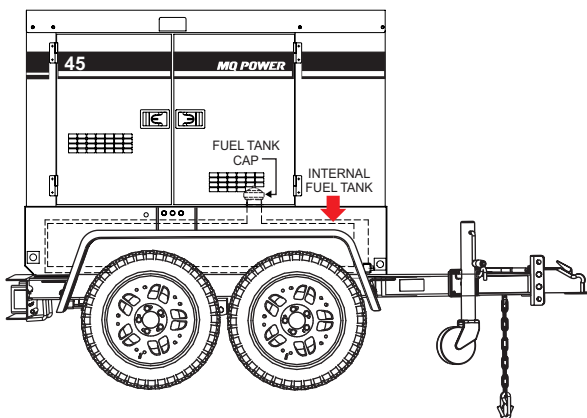

Figure 31. Fuel Tank

## Refueling Procedure

### WARNING



**Diesel fuel** and its vapors are dangerous to your health and the surrounding environment. Avoid skin contact and/or inhaling fumes.

1. **Level Tanks** — Make sure fuel cells are level with the ground. Failure to do so will cause fuel to spill from the tank before reaching full capacity (Figure 32).

### CAUTION

**ALWAYS** place the trailer on firm, level ground before refueling to prevent spilling and maximize the amount of fuel that can be pumped into the tank.

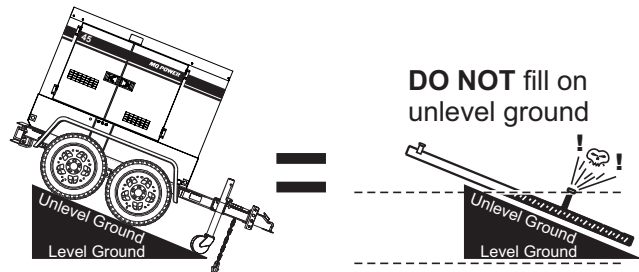

Figure 32. Only Fill On Level Ground

### NOTICE

**ONLY** use **#2 diesel fuel** when refueling.

2. Open cabinet doors on the “right side” of the generator (from the generator control panel position). Remove the fuel cap and fill the tank (Figure 33).

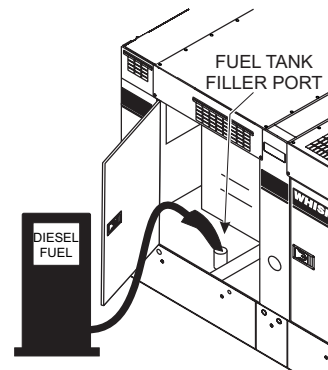

Figure 33. Fueling The Generator

# INSPECTION/SETUP

- NEVER overfill the fuel tank** — It is important to read the fuel gauge when filling the trailer fuel tank. **DO NOT** wait for fuel to rise in the filler neck (Figure 34).

FUEL GAUGE LOCATED ON CONTROL PANEL

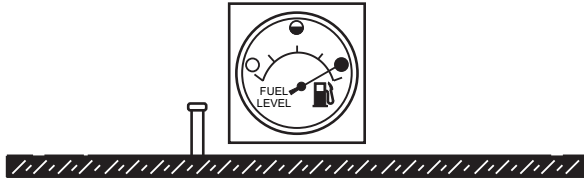

Figure 34. Full Fuel Tank

## CAUTION

**DO NOT OVERFILL** the fuel system. Leave room for fuel expansion. Fuel expands when heated (Figure 35).

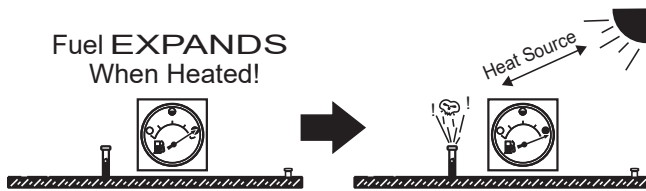

Figure 35. Fuel Expansion

## COOLANT (ANTIFREEZE/SUMMER COOLANT/WATER)

**Isuzu** recommends antifreeze/summer coolant for use in their engines, which can be purchased in concentrate (and mixed with 50% demineralized water) or pre-diluted. See the **Isuzu Engine Owner's Manual** for further details.

## WARNING



If adding coolant/antifreeze mix to the radiator, **DO NOT** remove the radiator cap until the unit has completely cooled. The possibility of **hot!** coolant exists which can cause severe burns.

Day-to-day addition of coolant is done from the recovery tank. When adding coolant to the radiator, **DO NOT** remove the radiator cap until the unit has completely cooled. See Table 12 for engine, radiator, and recovery tank coolant capacities.

## NOTICE

Normally, only the coolant level in the recovery tank needs to be checked. However, the radiator cap should be opened once a week to verify that coolant is visible (full) inside the radiator.

- Verify that the coolant level in the coolant recovery tank is between the **FULL** and **LOW** markings as shown in Figure 36.

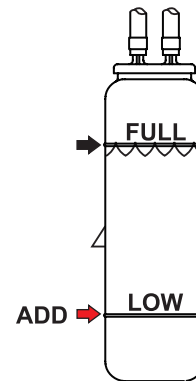

Figure 36. Coolant Recovery Tank

Table 12. Coolant Capacity

Engine and Radiator	4.44 gal. (16.8 liters)
Reserve Tank	0.29 gal (1.1 liters)

## Operation In Freezing Weather

When operating in freezing weather, be certain the proper amount of antifreeze (Table 13) has been added.

Table 13. Antifreeze Operating Temperatures

Vol % Antifreeze	Freezing Point	
	°C	°F
50	-37	-34

## NOTICE

When the antifreeze is mixed with water, the antifreeze mixing ratio **must be** less than 50%.

## Cleaning The Radiator

The engine may overheat if the radiator cooling fins (Figure 37) become overloaded with dust or debris. Periodically clean the radiator fins with compressed air. Cleaning inside the machine is dangerous, so clean only with the engine turned off and the **negative** battery terminal disconnected.

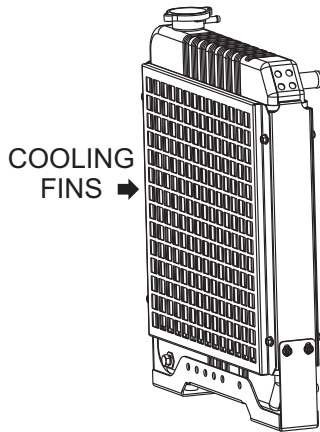

Figure 37. Radiator (Cooling Fins)

## ENGINE AIR CLEANER

Periodic cleaning/replacement of the air cleaner is necessary. Inspect the air cleaner (Figure 38) in accordance with the maintenance section of this manual or the **Isuzu Engine Owner's Manual**.

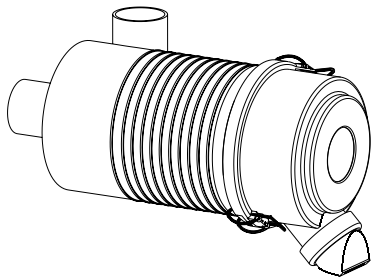

Figure 38. Engine Air Cleaner

## FAN BELT TENSION

A slack fan belt may contribute to overheating, or to insufficient charging of the battery. Inspect the fan belt for damage and wear and adjust it in accordance with the maintenance section of this manual or the **Isuzu Engine Owner's Manual**.

The fan belt tension is proper if the fan belt bends 0.22–0.24 in. (5.5–6.0 mm) when pressed with the thumb as shown in Figure 39.

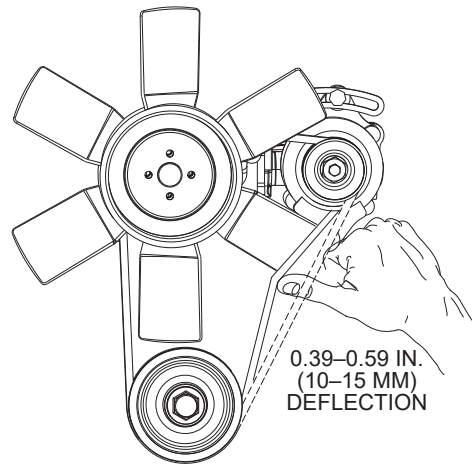

Figure 39. Fan Belt Tension

### CAUTION



**NEVER** place hands near the belts or fan while the generator set is running.

## BATTERY

This unit is of negative ground. **DO NOT** connect in reverse. Always maintain battery fluid level between the specified marks. Battery life will be shortened if the fluid levels are not properly maintained. Add only distilled water when replenishment is necessary.

**DO NOT** overfill. Check to see whether the battery cables are loose. Poor contact may result in poor starting or malfunctions. **ALWAYS** keep the terminals firmly tightened. Coat the terminals with an approved battery terminal treatment compound. Replace the battery with only the recommended type battery. The battery type used in this generator is BCI Group 27.

The battery is sufficiently charged if the specific gravity of the battery fluid is 1.28 (at 68°F). If the specific gravity should fall to 1.245 or lower, it indicates that the battery is dead and needs to be recharged or replaced.

Before charging the battery with an external electric source, be sure to disconnect the battery cables.



## Battery Cable Installation

**ALWAYS** be sure the battery cables (Figure 40) are properly connected to the battery terminals as shown below. The **red cable** is connected to the positive terminal of the battery, and the **black cable** is connected to the negative terminal of the battery.

### **CAUTION**

**ALWAYS** disconnect the negative terminal **FIRST** and reconnect the negative terminal **LAST**.

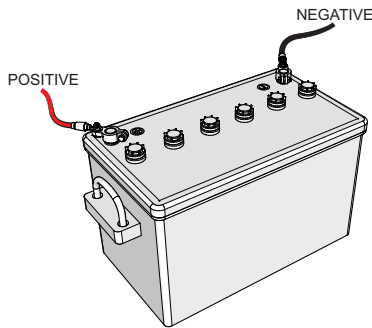

**Figure 40. Battery Connections**

When connecting the battery do the following:

1. **NEVER** connect the battery cables to the battery terminals when the **Auto Start/Stop switch** is in either the **AUTO** or **MANUAL** position. **ALWAYS** make sure that this switch is in the **OFF/RESET** position when connecting the battery.
2. Place a small amount of battery terminal treatment compound around both battery terminals. This will ensure a good connection and will help prevent corrosion around the battery terminals.

### **NOTICE**

If the battery cable is connected incorrectly, electrical damage to the generator will occur. Pay close attention to the polarity of the battery when connecting the battery.

### **CAUTION**

Inadequate battery connections may cause poor starting of the generator, and create other malfunctions.

## ALTERNATOR

The polarity of the alternator is negative grounding type. When an inverted circuit connection takes place, the circuit will be in short circuit instantaneously, resulting in alternator failure.

**DO NOT** put water directly on the alternator. Entry of water into the alternator can cause corrosion and damage the alternator.

## WIRING

Inspect the entire generator for bad or worn electrical wiring or connections. If any wiring or connections are exposed (insulation missing) replace wiring immediately.

## PIPING AND HOSE CONNECTIONS

Inspect all piping, oil hose, and fuel hose connections for wear and tightness. Tighten all hose clamps and check hoses for leaks.

If any hose (fuel or oil) lines are defective replace them immediately.

# GENERATOR START-UP PROCEDURE (MANUAL)

## BEFORE STARTING

### CAUTION

The engine's exhaust contains harmful emissions. **ALWAYS** have adequate ventilation when operating. Direct exhaust away from nearby personnel.

### WARNING

**NEVER** manually start the engine with the main, GFCI or auxiliary circuit breakers in the **ON** (closed) position.

1. Place the **main, auxiliary, and GFCI** circuit breakers (Figure 41) in the **OFF** position prior to starting the engine.

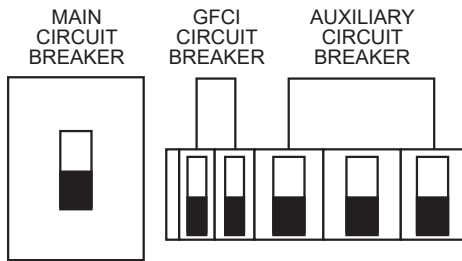

**Figure 41. Main, Auxiliary And GFCI Circuit Breakers (OFF)**

2. Make sure the **Voltage Selector switch** (Figure 42) has been configured for the desired output voltage.

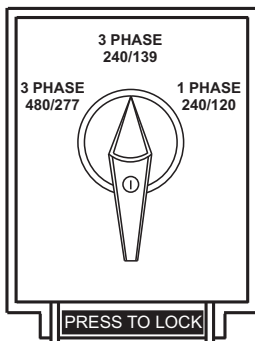

**Figure 42. Voltage Selector Switch**

3. Make sure the **Diagnostic switch** (located inside the control box) is placed in the **OFF** position. See Figure 43. Make sure the control panel is closed properly before proceeding.

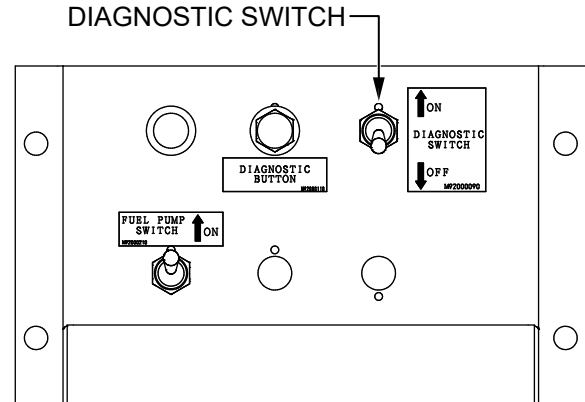

**Figure 43. Diagnostic Switch (OFF Position)**

4. Connect the load to the **receptacles, output terminal lugs**, or optional **cam-locks** as shown in Figure 10. These load connection points can be found on the output terminal panel and the output terminal panel's hard wire hookup panel.

### NOTICE

**ALWAYS** make sure that the connections to the UVWO terminals are **secure** and **tight**. The possibility exists of arcing that could cause a fire. Torque tie bolts to 130.1 lbf-in (14.7 N·m).

5. Close all engine enclosure doors (Figure 44).

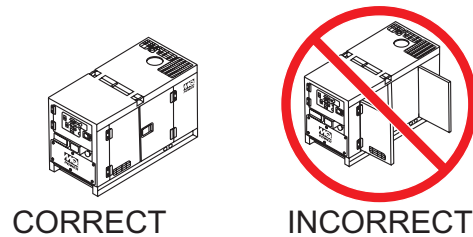

**Figure 44. Engine Enclosure Doors**

# GENERATOR START-UP PROCEDURE (MANUAL)

## STARTING (MANUAL)

1. Place the **Engine Speed switch** in the **LOW** position (Figure 45).



Figure 45. Engine Speed Switch (Low Position)

2. To start the engine, place the **Auto Start/Stop switch** in the **MANUAL** position (Figure 46).

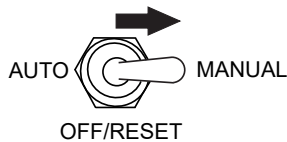

Figure 46. Auto Start/Stop switch (Manual Position)

### NOTICE

If the engine fails to start within three attempts, the Over Crank LED will turn on and the Auto Start/Stop switch must be placed in the Off/Reset position before the next attempt.

### NOTICE

The engine will pre-heat automatically in cold weather conditions. The Pre-Heat lamp will turn **ON** indicating that the pre-heating process has started. The engine will start automatically after pre-heating.

### NOTICE

Depending on the ambient temperature, the pre-heating process may still be performed even when the Preheat Lamp is **OFF**.

3. Once the engine starts, let the engine run for 1–2 minutes to warm up. For operation in below-freezing weather temperatures, this warmup period must be extended to 5–7 minutes. During the warmup period, check for any abnormal noise, vibration, or fluid leakage. If any abnormalities exist, shut down the engine and correct the problem.

4. After the warmup process has completed, place the **Engine Speed switch** in the **HIGH** (up) position. The engine speed will increase to 1,800 rpm and the unit is now ready for operation.

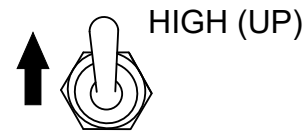

Figure 47. Engine Speed Switch (High Position)

5. The generator's **frequency meter** (Figure 48) should be displaying the 60-cycle output frequency in **HERTZ**.

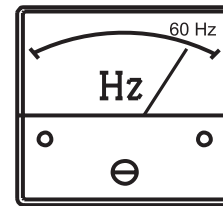

Figure 48. Frequency Meter

6. The generator's **AC voltmeter** (Figure 49) will display the generator's output in **VOLTS**.

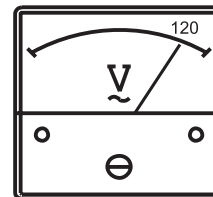

Figure 49. Voltmeter

7. If the voltage is not within the specified tolerance, use the **voltage regulator** (Figure 50) to increase or decrease the desired voltage.



Figure 50. Voltage Regulator

# GENERATOR START-UP PROCEDURE (MANUAL)

8. The **ammeter** (Figure 51) will indicate **zero amps** with no load applied. When a load is applied, the ammeter will indicate the amount of current that the load is drawing from the generator.

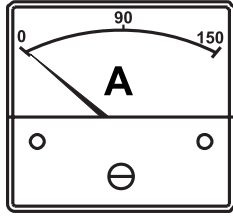

**Figure 51. Ammeter (No Load)**

9. The **engine oil pressure gauge** (Figure 52) will indicate the oil pressure of the engine. Under normal operating conditions the oil pressure should be approximately 50 psi (345 kPa). When starting the generator the oil pressure may read a little higher, but after the engine warms up the oil pressure should return to the correct pressure range.



**Figure 52. Oil Pressure Gauge**

10. The **coolant temperature gauge** (Figure 53) will indicate the coolant temperature. Under normal operating conditions the coolant temperature should be approximately 180°F (82°C).

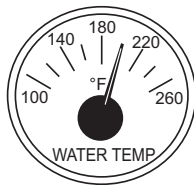

**Figure 53. Coolant Temperature Gauge**

11. The **tachometer gauge** (Figure 54) will indicate the speed of the engine in RPM. Under normal operating conditions this speed is approximately 1,800 rpm.

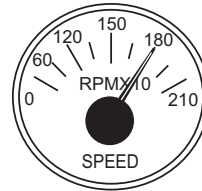

**Figure 54. Engine Tachometer Gauge**

12. Place the **main, auxiliary, and GFCI** circuit breakers in the **ON** position (Figure 55).

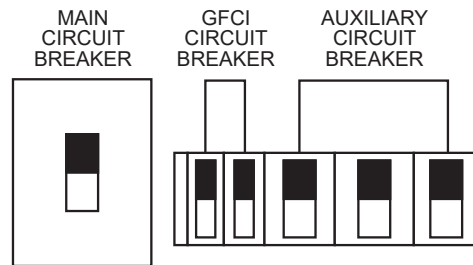

**Figure 55. Main, Auxiliary, And GFCI Circuit Breakers (ON)**

13. Observe the generator's **ammeter** (Figure 56) and verify it reads the anticipated amount of current with respect to the load. The ammeter will only display a current reading if a load is in use.

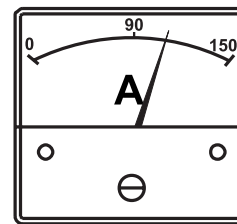

**Figure 56. Ammeter (Load)**

14. The generator will run until manually stopped or an abnormal condition occurs.

# GENERATOR START-UP PROCEDURE (AUTO MODE)

## STARTING (AUTO MODE)

### DANGER



Before connecting this generator to any building's electrical system, a **licensed electrician** must install an **isolation (transfer) switch**. Serious damage to the building's electrical system may occur without this transfer switch.

### NOTICE

When connecting the generator to an isolation (transfer) switch, **ALWAYS** have power applied to the generator's internal battery charger. This will ensure that the engine will not fail due to a dead battery.

### NOTICE

When the generator is set to **AUTO** mode, the generator will **automatically start** in the event of commercial power falling below a prescribed level by means of a contact closure that is generated automatically by a transfer switch.

### WARNING

When operating the generator in **AUTO** mode, remember that the generator can start up at any time without warning. **NEVER** attempt to perform any maintenance while the generator is in Auto mode.

### CAUTION

The Engine Speed switch **must** be set to the **High position** when running in **Auto mode**. Failing to set the switch in the proper position can result in damage to the generator when it turns on.

### NOTICE

When the **Auto Start/Stop switch** is placed in the **AUTO** position, the engine glow plugs will be warmed and the engine will start automatically.

1. Perform steps 1–5 under **Before Starting** in the **Generator Start-Up Procedure (Manual)** section.

2. Place the **Engine Speed switch** in the **HIGH** position (Figure 57).



**Figure 57. Engine Speed Switch (High Position)**

3. Place the **Auto Start/Stop switch** (Figure 58) in the **AUTO** position.



**Figure 58. Auto Start/Stop Switch (AUTO)**

4. Once the start signal is received (the remote-start contacts are closed), the pre-heating process will begin. When the pre-heating process has completed, the engine will start automatically and accelerate to rated speed. When the remote-start contacts are opened, the engine will stop.

5. If the engine fails to start, perform the manual starting procedure.

# GENERATOR SHUTDOWN PROCEDURE

## NORMAL SHUTDOWN PROCEDURE

### WARNING

**NEVER** stop the engine suddenly except in an emergency.

To shut down the generator, use the following procedure:

1. Place the load's ON/OFF switch in the **OFF** position.
2. Place the **main, auxiliary, and GFCI circuit breakers** in the **OFF** position (Figure 59).

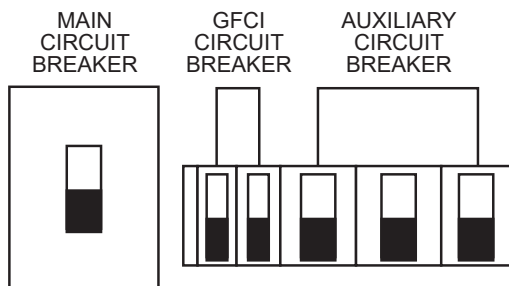

**Figure 59. Main, Aux. and GFCI Circuit Breakers (OFF)**

3. Place the **Engine Speed switch** in the **LOW** position (Figure 60).



**Figure 60. Engine Speed Switch (Low Position)**

4. Let the engine cool by running it at low speed for 3–5 minutes with no load applied.
5. Place the **Auto Start/Stop switch** (Figure 61) in the **OFF/RESET** position.

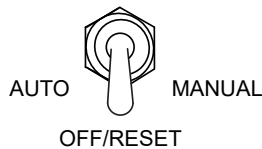

**Figure 61. Auto Start/Stop Switch (Off/Reset Position)**

### NOTICE

**DO NOT** disconnect the battery cables immediately after the engine stops. Wait for at least 30 seconds before disconnecting the battery cables.

6. Allow adequate time for cooling, then inspect the entire generator for any damage or loosening of components that may have occurred during operation.

## EMERGENCY SHUTDOWN PROCEDURE

### NOTICE

The **Emergency Stop switch** should only be used to stop the engine in case of an emergency or to lock out operation during service. The **Emergency Stop switch** should **NEVER** be used for routine stopping of the engine.

1. To stop the engine in the event of an emergency, press the **Emergency Stop switch** (Figure 62), located on the side of the generator next to the output terminal panel.

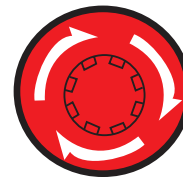

**Figure 62. Emergency Stop Switch**

2. Place the **main, auxiliary, and GFCI circuit breakers** in the **OFF** position as shown in Figure 59.
3. The Emergency Stop switch is a push-locked type switch. The switch contact can only be released by rotating the button in the clockwise direction. The engine cannot be restarted until the contact is released (closed).

## AUTOMATIC SHUTDOWN SYSTEM

This unit is equipped with safety devices that will automatically shut down the engine in the event of low oil pressure (approximately 14 psi / 97 kPa), high water temperature (approximately 212°F/100°C), or over speed (approximately +15%). The alarm lamps on the ECU will illuminate to signify the reason for the shutdown.

### NOTICE

Before inspecting the generator after an automatic shutdown, place the Auto Start/Stop switch in the **OFF/RESET** position, and place all circuit breakers in the **OFF** position. Allow adequate time for cooling before troubleshooting. When all faults have been cleared, restart the engine according to the **Generator Startup Procedure** section of this manual.

# MAINTENANCE

Table 14. Inspection/Maintenance		10 Hours or Daily	250 Hours	500 Hours or Every 12 Months	3,000 Hours or Every 36 Months	Other
Engine	Check Engine Oil and Coolant Levels	X				
	Check Fuel Filter/Water Separator Bowl	X				
	Check Air Cleaner	X				
	Check Air Cleaner Element	X				
	Check for Leaks/Hoses/Clamps	X				
	Check for Loosening of Parts	X				
	Drain Water in Fuel	X				
	Change Engine Oil and Oil Filter * 1		X			
	Clean Unit, Inside and Outside		X			
	Replace Fuel Filter Elements			X		
	Check Engine Mounts			X		
	Service Battery			X		
	Check Air Intake Hoses			X		
	Check Fan Belt Condition (Replace if Necessary)	X				
	Check Automatic Belt Tensioner	X				
	Check Electrical Ground Connection			X		
	Clean Radiator, Check Cooling System			X		
	Coolant Solution Analysis, Add SCAs as Required			X		
	Pressure Test Cooling System			X		
	Check Engine Speed			X		
	Test Thermostats				X	
	Test Glow Plugs				X	
	Flush and Refill Cooling System					2 yrs. or 2,000 hours
	Clean Inside of Fuel Tank					1,000 hours
	Replace Air Cleaner Elements * 3					As required
Check Battery Acid Level	X					
Drain Environmental Tank		X				
Check All Hoses and Clamps					1,000 hours	
Generator	Measure Insulation Resistance Over 3M Ohms		X			
	Check Rotor Rear Support Bearing			X		

\*1 During initial operation of a new engine, change oil and filter between a minimum of 100 hours and a maximum of 250 hours. Service interval depends on type of oil.

\*2 Add "Supplemental Coolant Additives" (SCAs) to recharge the engine coolant.

\*3 Replace the primary air filter element when the restriction indicator shows a vacuum of 625 mm (25 in. H<sub>2</sub>O).

\*4 If the blowby hose needs to be replaced, ensure that the slope of the blowby hose is at least 1/2 inch per foot, with no sags or dips that could collect moisture and/or oil.

\*5 Accumulation of carbon (soot, unburned fuel) in the exhaust pipe line and muffler could cause not only system derates but also could lead to fire incident. To destroy the soot and unburned fuel, run the unit at rated power for some period of time until the exhaust gas become mostly colorless every 250 hours of operation time. The carbon will be easier to be generated when the unit operates at less then 40% of rated power. In this case, perform the above procedures at a shorter interval time.

\*6 Applying a large load at one time to the unit when carbon deposits have accumulated in the exhaust system could produce fire/sparks which could lead to abnormal combustion. Therefore it is recommended to **apply the load gradually** and observe the exhaust gas color (colorless) during the process.

\*7 Fire or sparks may emit from the exhaust gas outlet during the **carbon emission accumulation check** (load). Make sure the area surrounding the unit is free from any **flammable** material.

## GENERAL INSPECTION

Prior to each use, the generator should be cleaned and inspected for deficiencies. Check for loose, missing or damaged nuts, bolts or other fasteners. Also check for fuel, oil, and coolant leaks. Use Table 14 as a general maintenance guideline. For more detailed engine maintenance instructions, refer to the engine owner's manual.

## ENGINE AIR CLEANER

This Isuzu diesel engine is equipped with a replaceable, high-density, paper air cleaner element (Figure 63). The air cleaner is also equipped with an inner (secondary) element that is used as a backup filter should the primary element become damaged. Check the air cleaner daily or before starting the engine. Replace the air cleaner as needed.

### NOTICE

If the engine is operating in very dusty or dry grass conditions, a clogged air cleaner will result. This can lead to a loss of power, excessive carbon buildup in the combustion chamber, and high fuel consumption. Change the air cleaner more frequently if these conditions exist.

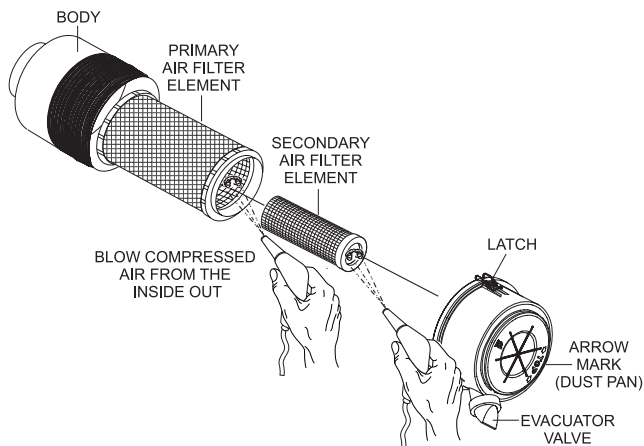

Figure 63. Engine Air Cleaner

## Primary And Secondary Air Cleaner Elements

**Every 250 hours:** Remove the air cleaner elements and clean them with a light spray of compressed air.

### CAUTION



Wear protective equipment such as approved safety glasses or face shields and dust masks or respirators when cleaning air filters with compressed air.

1. Release the latches that secure the cover to the air cleaner body (Figure 63).
2. Remove the air cleaner cover (Figure 63) and set it aside.
3. Remove both the primary and secondary air cleaner elements (Figure 63).
4. Check for and correct heavy buildup of dirt and debris along with loose or damaged components.

### NOTICE

Operating the engine with loose or damaged air cleaner components could allow unfiltered air into the engine causing premature wear and failure.

5. To clean the primary element (paper air filter) as shown in Figure 63, tap the filter element several times on a hard surface to remove dirt, or blow compressed air, not to exceed 30 psi (207 kPa, 2.1 kgf/cm<sup>2</sup>), through the filter element from the inside out.
6. Clean the secondary element (paper air filter) as described in step 5.
7. Replace both elements if they are damaged or excessively dirty.
8. Clean the inside of the air cleaner body (Figure 63).
9. Reinstall the primary and secondary air filter elements back into the air cleaner body.
10. Reinstall the air cleaner cover and secure with latches.

### NOTICE

**DO NOT** run the engine with the air cleaner removed or without an element.



## Air Cleaner Restriction Indicator

The air cleaner is equipped with a restriction indicator (Figure 64). As the air cleaner element becomes clogged, air intake restriction increases and the indicator signal shows **RED**, indicating that the element needs to be replaced. After replacing the air cleaner element, press the restriction indicator button to reset the indicator.

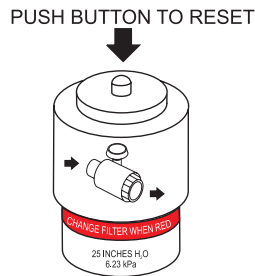

Figure 64. Air Cleaner Restriction Indicator

### NOTICE

The air cleaner element should not be changed until the indicator displays **RED**. Dispose of the old element. It cannot be cleaned or reused.

## ENGINE FUEL FILTER

Inspect the engine fuel filter daily. If the fuel filter has collected a significant amount of water and sediment at the bottom of the cup, it should be drained off immediately.

## Draining The Fuel Filter

1. Loosen the air bleeder plug (Figure 65) on the fuel filter body.

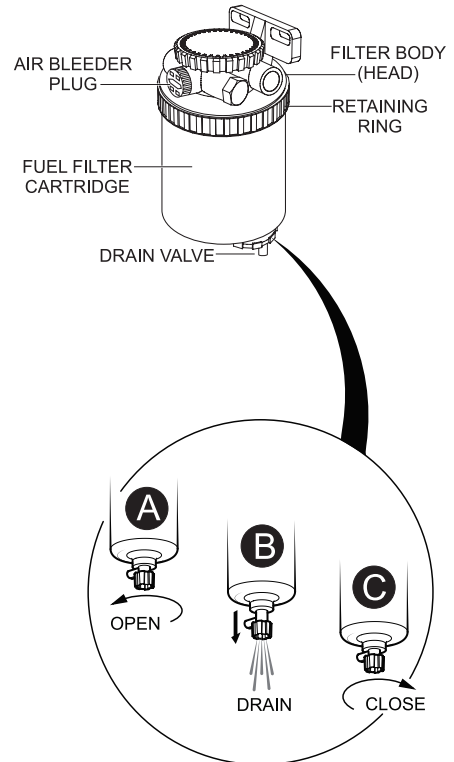
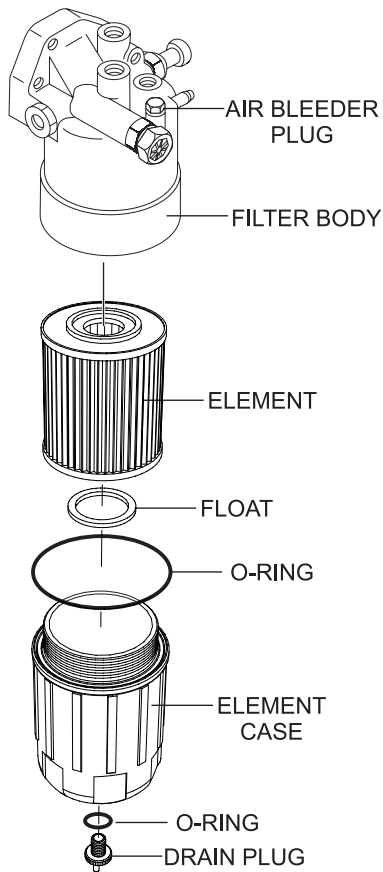

Figure 65. Draining The Fuel Filter

2. To discharge the fuel inside the fuel filter, **OPEN** the drain valve on the fuel filter by turning the knob **counterclockwise (A)** approximately 3-1/2 turns until the valve drops down 1 inch (25.4 mm) and draining occurs **(B)**.
3. Let the residue or foreign substances inside the case flow into a suitable container.
4. At completion of draining, close the drain valve (Figure 65**C**).

## FUEL FILTER ELEMENT REPLACEMENT

1. Use a filter wrench to remove the element case (Figure 66) from the fuel filter body.



**Figure 66. Fuel Filter Replacement**

2. Wipe the inside of the filter body with a clean cloth to remove any foreign matter or debris that may have accumulated.
3. Insert the new fuel filter element into the element case.
4. Replace both O-rings. Coat each O-ring with a small amount of clean 15W-40 engine oil.
5. Reinstall the element case first by hand until it makes contact with the fuel filter body surface.
6. Torque the element case to 22.4 lbf·ft (30 N·m).
7. Torque the drain plug to 1.4 lbf·ft (2.0 N·m).
8. Remove the air from the fuel system. Reference the Isuzu Owner's Manual, "Bleeding the Fuel System."

## ELECTROMAGNETIC FUEL PUMP (500 HOURS)

The filter inside the fuel pump (Figure 67) is either a paper type or steel mesh type depending on the fuel pump type. Clean or replace the fuel pump filter as follows:

1. Disconnect any electrical connections that are attached to the fuel pump.
2. Prepare a fuel collector to drain the fuel into. Secure any fuel lines to prevent fuel from spilling.
3. Remove the fuel pump from the generator enclosure.
4. Remove the filter and gasket from the fuel pump housing.

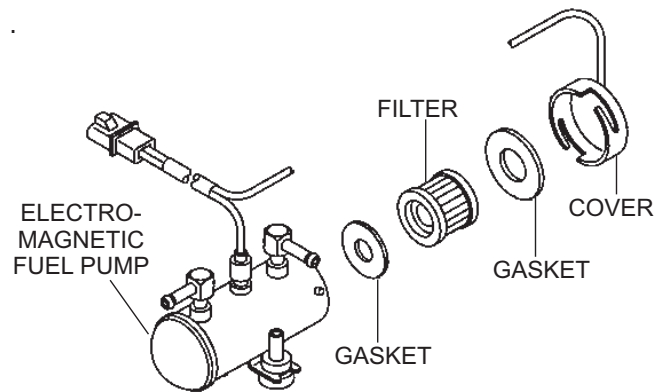

**Figure 67. Electromagnetic Fuel Pump**

### NOTICE

When the fuel pump filter is removed, always make sure to replace both gaskets and clean the magnet portion inside the cover.

5. Clean or replace the fuel pump filter. Replace both gaskets.
6. Reassemble the fuel pump and mount it back onto the generator enclosure.
7. Reconnect all fuel lines and electrical components.
8. Check for fuel leaks.

## DRAINING THE CONTAINMENT TANK

1. This generator is equipped with an environmental containment tank. Inspect this tank regularly.
2. If the tank becomes full with fluids, remove the drain bolt (Figure 68), then allow the fluids to drain into a suitable container.

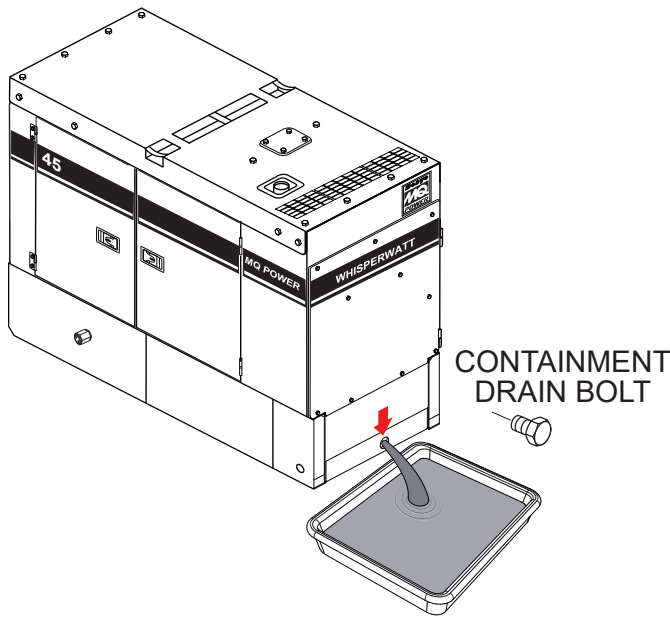

Figure 68. Draining The Containment Tank

## REMOVING WATER FROM THE FUEL TANK

After prolonged use, water and other impurities accumulate in the bottom of the fuel tank. Occasionally inspect the fuel tank for water contamination and drain the contents if required.

During cold weather, the more empty volume inside the tank, the easier it is for water to condense. This can be reduced by keeping the tank full with diesel fuel.

## CLEANING INSIDE THE FUEL TANK

If necessary, drain the fuel inside the fuel tank completely. Using a spray washer (Figure 69) wash out any deposits or debris that have accumulated inside the fuel tank.

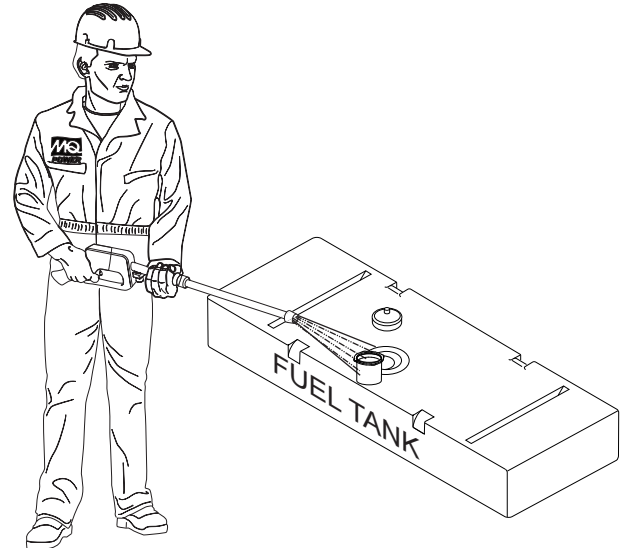

Figure 69. Cleaning The Fuel Tank

## FUEL TANK INSPECTION

In addition to cleaning the fuel tank, the following components should be inspected for wear:

- **Rubber Suspension** — Look for signs of wear or deformity due to contact with oil. Replace the rubber suspension if necessary.
- **Fuel Hoses** — Inspect nylon and rubber hoses for signs of wear, deterioration or hardening.
- **Fuel Tank Lining** — Inspect the fuel tank lining for signs of excessive amounts of oil or other foreign matter.

## DRAINING THE ENGINE OIL

1. Run the engine until the engine coolant reaches a temperature of 140°F (60°C).
2. Turn the engine **OFF**.
3. Remove the oil dipstick from its holder.
4. Remove the **oil drain cap** (Figure 70).

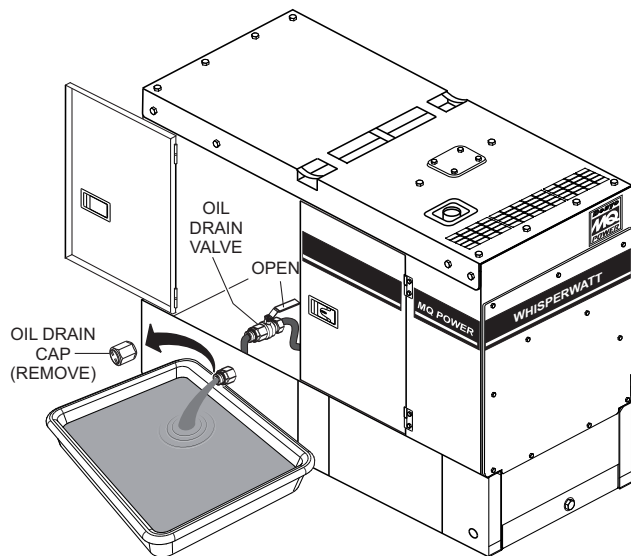
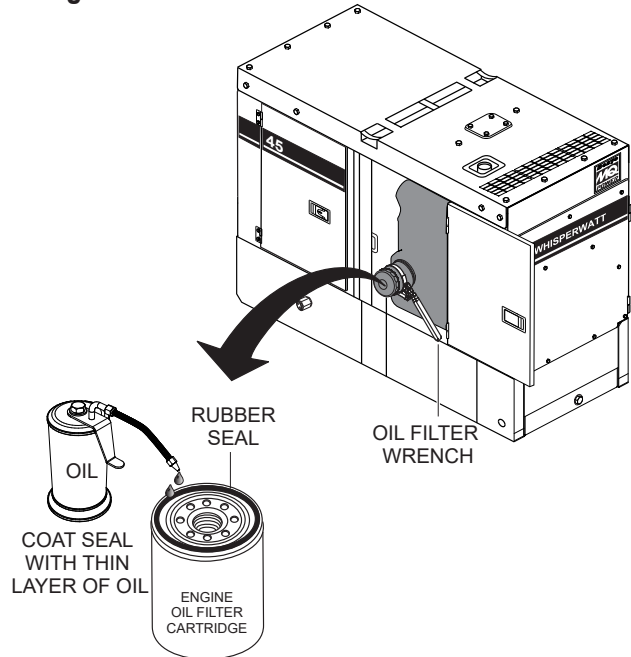

**Figure 70. Draining The Engine Oil**

5. Place the **oil drain valve** in the **OPEN** position (Figure 70) and allow the oil to drain into a suitable container.
6. After the engine oil has completely drained, reinstall the oil drain cap and tighten securely.
7. Place the oil drain valve in the **CLOSED** position.

## ENGINE OIL FILTER REPLACEMENT

1. Clean the area around the lubricating oil filter head.
2. Using an **oil filter wrench** (Figure 71), remove the **engine oil filter**.



**Figure 71. Oil Filter Replacement**

3. Coat the rubber seal (gasket) surface of the oil filter (Figure 71) with clean 15W-40 engine oil.
4. Install the new oil filter (main) first by hand until it makes contact with the filter head surface. Tighten it another 3/4 turn using the filter wrench.
5. Fill the engine crankcase with high-quality detergent oil classified "For Service CI-4." Fill to the upper limit of the dipstick. **DO NOT** overfill. Reference Table 2 for engine crankcase oil capacity.
6. Run the engine for several minutes. Watch for oil leakage. Shut the engine down and allow it to sit for several minutes. Top off the oil to the upper limit on the dipstick.

## DRAINING THE ENGINE COOLANT

### WARNING



**DO NOT** remove the pressure cap from the radiator when the engine is hot! Wait until the coolant temperature is below 120°F (50°C) before removing the pressure cap. Heated coolant spray or steam can cause severe scalding and personal injury.

1. Remove the **radiator pressure cap** (Figure 72) only if the coolant temperature is below 120°F (50°C).

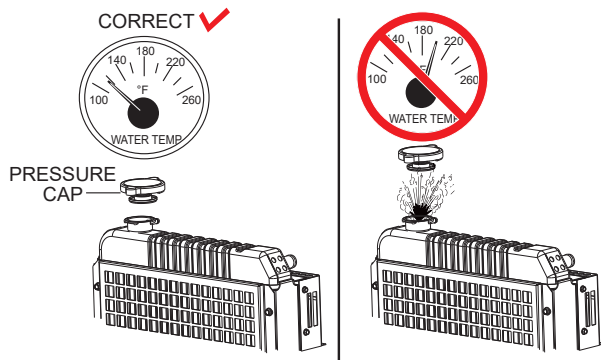

**Figure 72. Radiator Pressure Cap Removal**

2. Open the cabinet door and remove the **coolant drain bolt** and **O-ring** (Figure 73), then allow the coolant to drain into a suitable container.

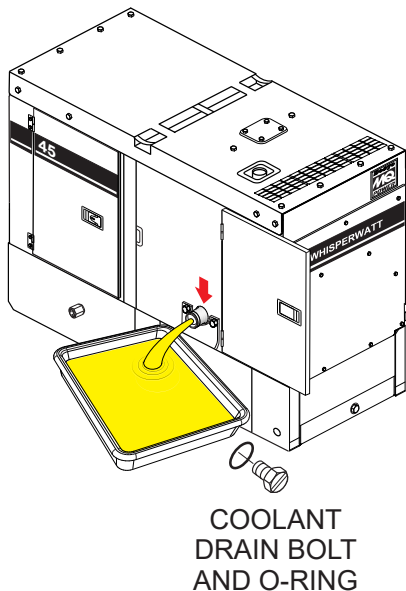

**Figure 73. Draining The Engine Coolant**

3. After the coolant has completely drained, reinstall the coolant drain bolt and O-ring.

4. Reinstall the radiator pressure cap and tighten securely.
5. Flush out the radiator and replace the coolant. Refer to **Cleaning the Coolant Passages** and **Filling the Coolant System** in the Isuzu engine owner's manual.

## RADIATOR CLEANING

The radiator (Figure 74) should be sprayed (cleaned) with a high-pressure washer when excessive amounts of dirt and debris have accumulated on the cooling fins or tube. When using a high-pressure washer, stand at least 5 feet (1.5 meters) away from the radiator to prevent damage to the fins and tube.

### NOTICE

It may be necessary to remove additional generator components in order to access the radiator for cleaning.



**Figure 74. Radiator Cleaning**

## DRIVE BELT (DAILY)

### Drive Belt Tension

A slack drive belt may contribute to overheating or insufficient charging of the battery. Adjust the drive belt in accordance with the Isuzu Operator's manual.

### Drive Belt Inspection

Inspect the **drive belt** (Figure 75) for damage and wear. Horizontal cracks (across the belt) are acceptable. Vertical cracks (direction of belt ribs) that intersect with horizontal cracks are not acceptable.

Also, examine the belt and determine if it is **oil soaked** or **glazed** (a hard shiny appearance on the sides of the belt). Either of these two conditions can cause the belt to run hot, which can weaken it and increase the danger of it breaking.

If the drive belt exhibits any of the above wear conditions, replace the drive belt immediately.

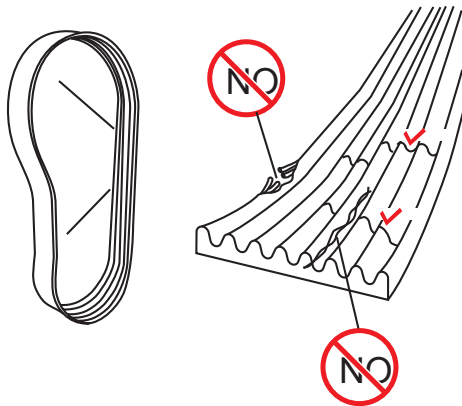

Figure 75. Drive Belt Inspection

## TESTING THE GFCI RECEPTACLE

### NOTICE

The GFCI receptacle is designed to interrupt power when a ground fault exists to prevent injuries and shock hazards. **DO NOT** use the GFCI receptacle if the test below fails. Consult a qualified electrician for repair or replacement of the GFCI receptacle. Test the GFCI receptacle **at least once a month**.

1. Start the generator as outlined in the start-up procedure in this manual.
2. Place a **GFCI circuit breaker** (Figure 76) in the **ON** position.

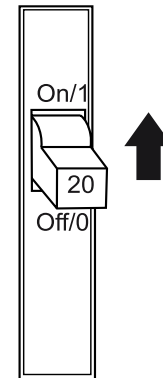

Figure 76. GFCI Circuit Breaker

3. Verify that the **status LED** on the corresponding **GFCI receptacle** (Figure 77) is **ON (GREEN)**.

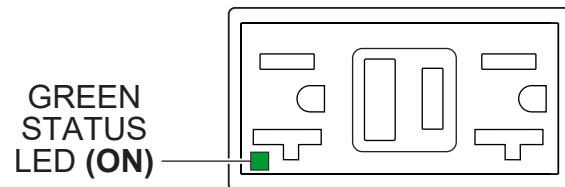
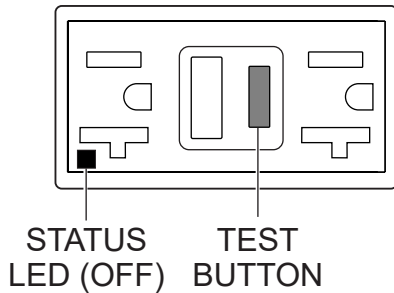

Figure 77. GFCI Receptacle (ON)

4. Press the **TEST button** (Figure 78) on the GFCI receptacle and verify that the status LED turns **OFF**.



**Figure 78. GFCI Receptacle (OFF)**

5. Press the **RESET button** (Figure 79) to restore power to the GFCI receptacle and verify that the status LED is **ON (GREEN)**.

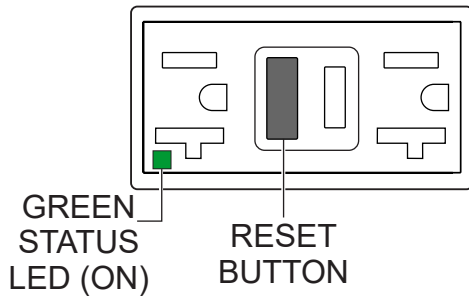

**Figure 79. GFCI Receptacle (ON/Restore)**

6. If the status LED (Figure 80) is **flashing (RED)**, **DO NOT** use the GFCI receptacle. Replace it immediately.

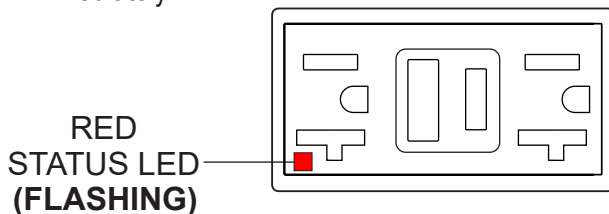

**Figure 80. GFCI Receptacle (Red Flashing LED)**

7. Repeat the above procedure for all other GFCI receptacles.

## GENERATOR STORAGE

For long-term storage of the generator the following is recommended:

- Drain the fuel tank completely. Treat with a fuel stabilizer if necessary.
- Completely drain the oil from the crankcase and refill if necessary with fresh oil.
- Clean the entire generator, internal and external.
- Cover the generator and store in a clean, dry place.
- Disconnect the battery.
- Make sure engine coolant is at the proper level.
- If the generator is mounted on a trailer, jack the trailer up and place it on blocks so the tires do not touch the ground, or block and completely remove the tires.

## OPTIONAL ENGINE BLOCK HEATER AND INTERNAL BATTERY CHARGER 120 VAC INPUT RECEPTACLES

An internal battery charger and an engine block heater are available as options. They are provided with electrical cords to connect to a commercial power source.

The engine block heater and internal battery charger both require 120 VAC in order to operate. A receptacle (Figure 81) has been provided on the output terminal panel to allow commercial power to be applied.

These receptacles will **ONLY** function when commercial power has been supplied to them (Figure 81). When using extension cords, refer to Table 6 for the correct size and length.

When using the generator in **hot** climates there is no reason to apply power to the engine block heater. However, if the generator will be used in **cold** climates it is always a good idea to apply power to the heater at all times.

If the generator will be used daily, the battery should normally not require charging. If the generator will be idle (not used) for long periods of time, apply power to the battery charger receptacle via commercial power using a power cord of adequate size.

### NOTICE

If the generator will be idle (not used) for long periods of time, **ALWAYS** keep power supplied to the generator's internal battery charger to ensure adequate starting capability.

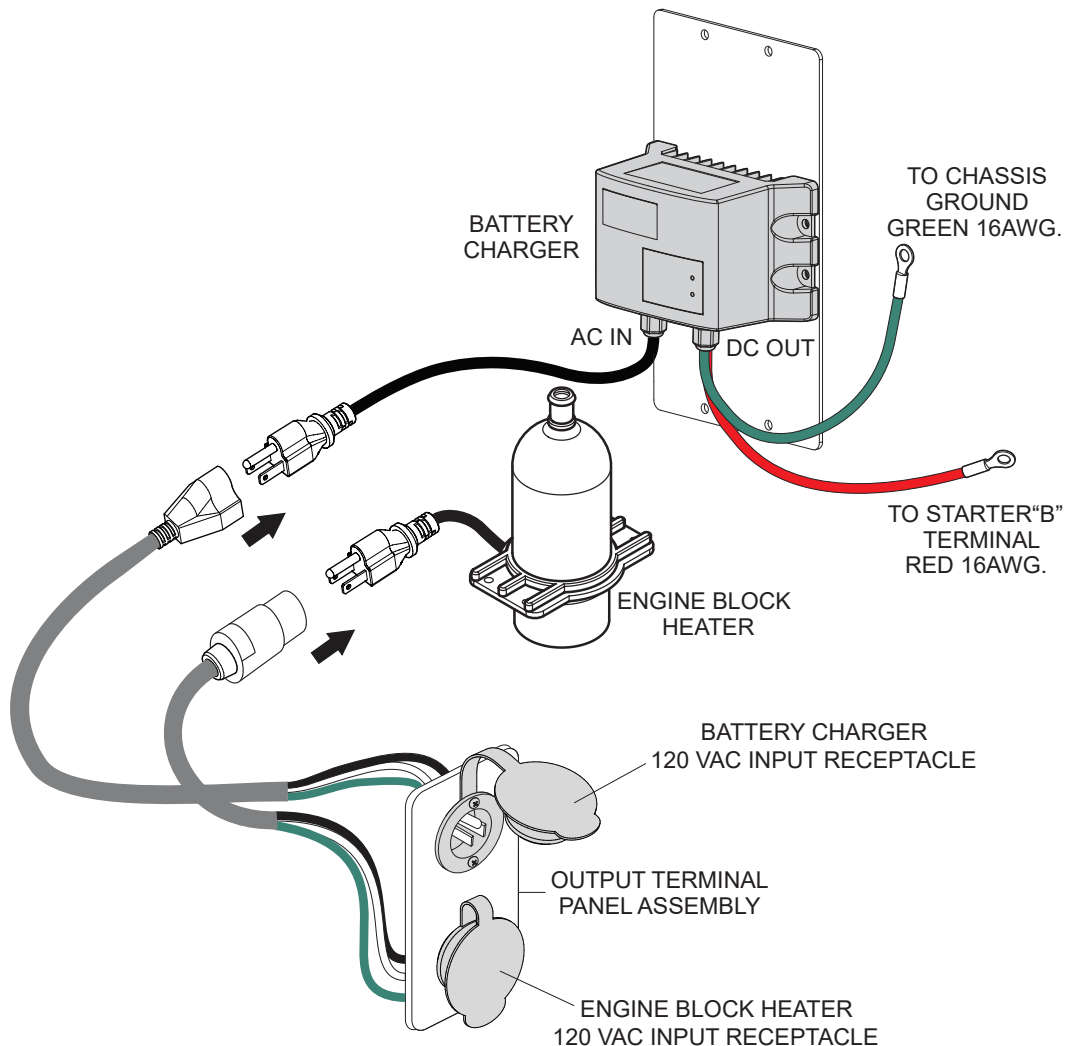

Figure 81. Optional Engine Block Heater And Battery Charger



## EMISSION CONTROL

The emission control system employed with the Isuzu 4LE2T diesel engine consists of a Diesel Oxidation Catalyst (DOC).

This device oxidizes large amounts of harmful nitrogen oxides (NO<sub>x</sub>) and particulate matter (PM) which are emitted by diesel engines. These exhaust emissions pose serious environmental and health risks. No maintenance or service is required for the DOC device used on this generator.

### Diesel Oxidation Catalyst (DOC)

The DOC (Figure 82) does not filter particles, it oxidizes them. This catalyst (honeycomb-like structure) uses a chemical process to break down pollutants in the exhaust stream into less harmful components. In general this catalyst collects/burns accumulated particulates. The DOC contains palladium and platinum which serve as catalysts to oxidize hydrocarbons and carbon monoxide.

## PREVENTIVE MAINTENANCE PROGRAMS

Most challenging to a rental organization is the fact that a customer's power assumptions may not meet the minimum load requirements of the power equipment selected. When in doubt, it is always recommended to apply a load bank application to the equipment following a longer rental period.

Equipment on extended, long-term contracts needs periodic on-site inspection. If possible, interview the operator and survey the equipment hooked up to the generator to estimate load conditions.

Preventive maintenance and a few extra steps prevent downtime and protect your investment and business. A well-planned preventive maintenance program will reward you with years of service.

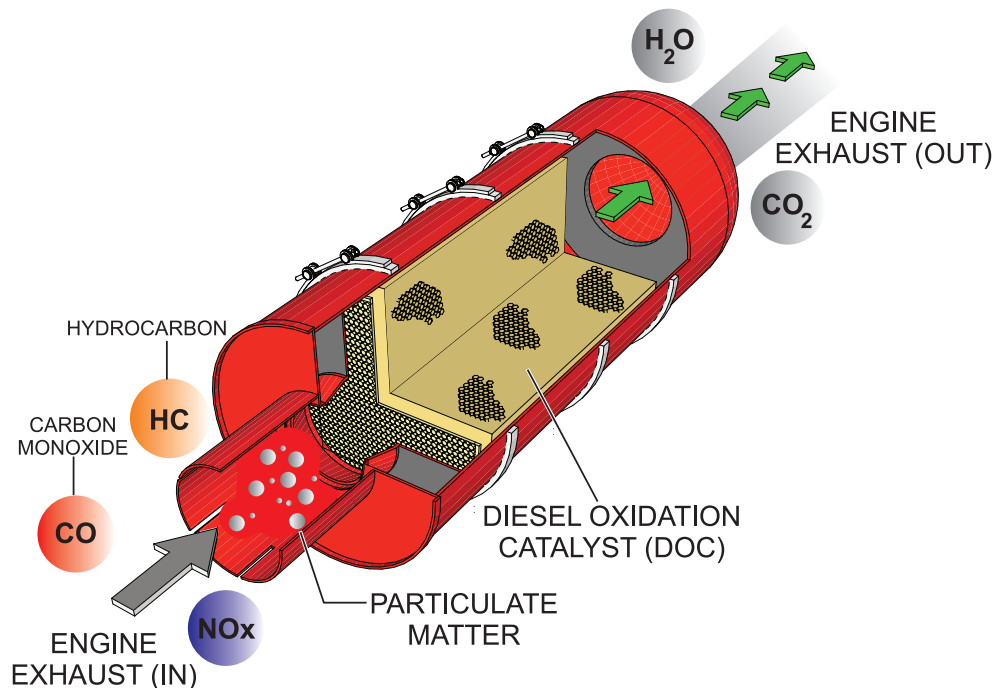

Figure 82. Diesel Oxidation Catalyst (DOC)

# TROUBLESHOOTING (DIAGNOSTICS)

## ENGINE FAULT DIAGNOSTICS

The engine controller of this generator diagnoses problems (faults/errors) that arise from the engine control system and the engine itself.

When an engine fault occurs during operation, the **Warning (Diagnostic) lamp** located on the control panel will turn **ON**. When this occurs, immediately perform the following engine fault code diagnostic procedure.

### Engine Fault Code Diagnostic Procedure

1. Remove all loads from the generator and place all circuit breakers in the **OFF** position.
2. Stop the engine.
3. Release the retaining screws that secure the control panel to the generator frame.
4. Slowly let the control panel fall forward so that the control box is exposed.
5. To start the diagnostic process, place the **Diagnostic switch** in the **ON** (Figure 83) position.

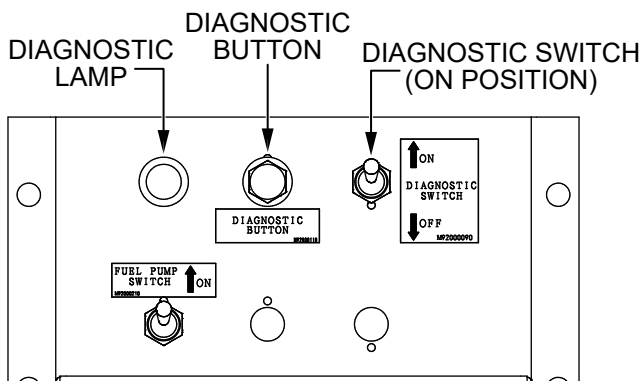

Figure 83. Diagnostic Panel

### NOTICE

Make sure to place the Diagnostic switch back to the **OFF** position after completing engine fault code diagnostic procedure.

6. Verify that the **Diagnostic lamp** (Figure 83) is **ON**. This indicates that there is a fault/error in the engine or the engine control system.

### NOTICE

If the Diagnostic switch is turned to the ON position under normal operating conditions (no fault/error), the Diagnostic lamp will only light for 3 seconds, then turn off.

7. Press and hold the **Diagnostic button** (Figure 83) to identify the fault and verify the following:
  - The **Diagnostic lamp** (Figure 83) will flash a pattern corresponding to the detected fault code 3 times at 2.4-second intervals.
  - If more than two fault codes are detected, the Diagnostic lamp will continuously repeat the detected fault codes' flashing patterns in ascending order.
  - If no fault is detected, the Diagnostic lamp will flash repeatedly at 2.4-second intervals.
8. Refer to the engine owner's manual for a complete understanding of error codes and troubleshooting procedures.
9. Upon completion of troubleshooting, place the **Diagnostic switch** in the **OFF** position.

### NOTICE

When a fault is detected, the fault code will automatically be saved as a previous code in the ECM even after the fault has been repaired.

### NOTICE

The Diagnostic lamp will indicate the current fault code with the previous fault code in ascending order.

### NOTICE

If a fault occurs while the engine is running, the Diagnostic lamp will turn on indicating only the current fault. Please note that the fault code blinking pattern cannot be shown while the engine is running.

## TROUBLESHOOTING (GENERATOR)

Practically all breakdowns can be prevented by proper handling and maintenance inspections, but in the event of a breakdown, use Table 15 shown below for diagnosis of the generator. If the problem cannot be remedied, consult our company's business office or service plant.

<b>Table 15. Generator Troubleshooting</b>		
<b>Symptom</b>	<b>Possible Problem</b>	<b>Solution</b>
No Voltage Output	Defective AC voltmeter?	Check output voltage and replace if necessary.
	Loose wiring connection?	Check wiring and repair.
	Defective AVR?	Replace if necessary.
	Defective rotating rectifier?	Check and replace.
Low Voltage Output	Loose wiring connection?	Check wiring and repair.
	Defective AVR?	Replace if necessary.
High Voltage Output	Loose wiring connection?	Check wiring and repair.
	Defective AVR?	Replace if necessary.
Circuit Breaker Tripped	Short circuit in load?	Check load and repair.
	Over current?	Confirm load requirement and reduce.
	Defective circuit breaker?	Check and replace.
	Overcurrent relay actuated?	Confirm load requirement and reset.

## TROUBLESHOOTING (ENGINE)

Troubleshooting (Engine)		
Symptom	Possible Problem	Solution
Engine will not start or start is delayed, although engine can be turned over.	No fuel reaching injection pump?	Add fuel. Check entire fuel system.
	Defective fuel pump?	Replace fuel pump.
	Fuel filter clogged?	Replace fuel filter and clean tank.
	Faulty fuel supply line?	Replace or repair fuel line.
	Compression too low?	Check piston, cylinder and valves. Adjust or repair per engine repair manual.
	Fuel pump not working correctly?	Repair or replace fuel pump.
	Oil pressure too low?	Check engine oil pressure.
	Low starting temperature limit exceeded?	Comply with cold starting instructions and proper oil viscosity.
	Defective battery?	Charge or replace battery.
	Air or water mixed in fuel system?	Check carefully for loosened fuel line coupling, loose cap nut, etc.
At low temperatures engine will not start.	Engine oil too thick?	Refill engine crankcase with correct type of oil for winter environment.
	Defective battery?	Replace battery.
Engine fires but stops as soon as starter is switched off.	Fuel filter blocked?	Replace fuel filter.
	Fuel supply blocked?	Check the entire fuel system.
	Defective fuel pump?	Replace fuel pump.
Engine stops by itself during normal operation.	Fuel tank empty?	Add fuel.
	Fuel filter blocked?	Replace fuel filter.
	Defective fuel pump?	Replace fuel pump.
	Mechanical oil pressure shutdown sensor stops the engine due to low oil?	Add oil. Replace low oil shutdown sensor if necessary.
Low engine power, output and speed.	Fuel tank empty?	Add fuel.
	Fuel filter clogged?	Replace fuel filter.
	Fuel tank venting is inadequate?	Ensure tank is adequately vented.
	Leaks at pipe unions?	Check threaded pipe unions. Tape and tighten unions as required.
	Speed control lever does not remain in selected position?	See engine manual for corrective action.
	Engine oil level too full?	Correct engine oil level.
	Injection pump wear?	Use No. 2-D diesel fuel only. Check the fuel injection pump element and delivery valve assembly and replace as necessary.

## TROUBLESHOOTING (ENGINE)

Troubleshooting (Engine) - continued		
Symptom	Possible Problem	Solution
Low engine power output and low speed, black exhaust smoke.	Air filter blocked?	Clean or replace air filter.
	Incorrect valve clearances?	Adjust valves per engine specification.
	Malfunction at injector?	See engine manual.
Engine overheats.	Too much oil in engine crankcase?	Drain off engine oil down to upper mark on dipstick.
	Entire cooling air system contaminated or blocked?	Clean cooling air system and cooling fin areas.
	Fan belt broken or elongated?	Change belt or adjust belt tension.
	Coolant insufficient?	Replenish coolant.
	Radiator net or radiator fin clogged with dust?	Clean net or fin carefully.
	Fan, radiator, or radiator cap defective?	Replace defective part.
	Thermostat defective?	Check thermostat and replace if necessary.
Head gasket defective or water leakage?	Replace parts.	

# GENERATOR WIRING DIAGRAM (M1814000413)

SYMBOL	DESIGNATION
Ar	MAIN GENERATOR ARMATURE WINDING
Fg	MAIN GENERATOR FIELD WINDING
ExAr	EXCITER ARMATURE WINDING
ExFg	EXCITER FIELD WINDING
Re	RECTIFIER
AVR	AUTOMATIC VOLTAGE REGULATOR
VR	VOLTAGE REGULATOR (REBOSTAT)
CT 1, 2, 3	CURRENT TRANSFORMER
AS	CHANGE-OVER SWITCH, AMMETER
A	AC. AMMETER
VS	CHANGE-OVER SWITCH, VOLTMETER
V	AC. VOLTMETER
F	FREQUENCY METER
CB1	CIRCUIT BREAKER 3P 110A
CB2, 3, 4	CIRCUIT BREAKER 2P 50A
CB5, 6	CIRCUIT BREAKER 1P 20A
CON1, 2, 3	RECEPTACLE 250V 50A
CON4, 5	RECEPTACLE 125V 20A*2 (G. F. C. I.)
OC	OVER CURRENT RELAY
SW	SELECTOR SWITCH
RY1, 2	RELAY UNIT

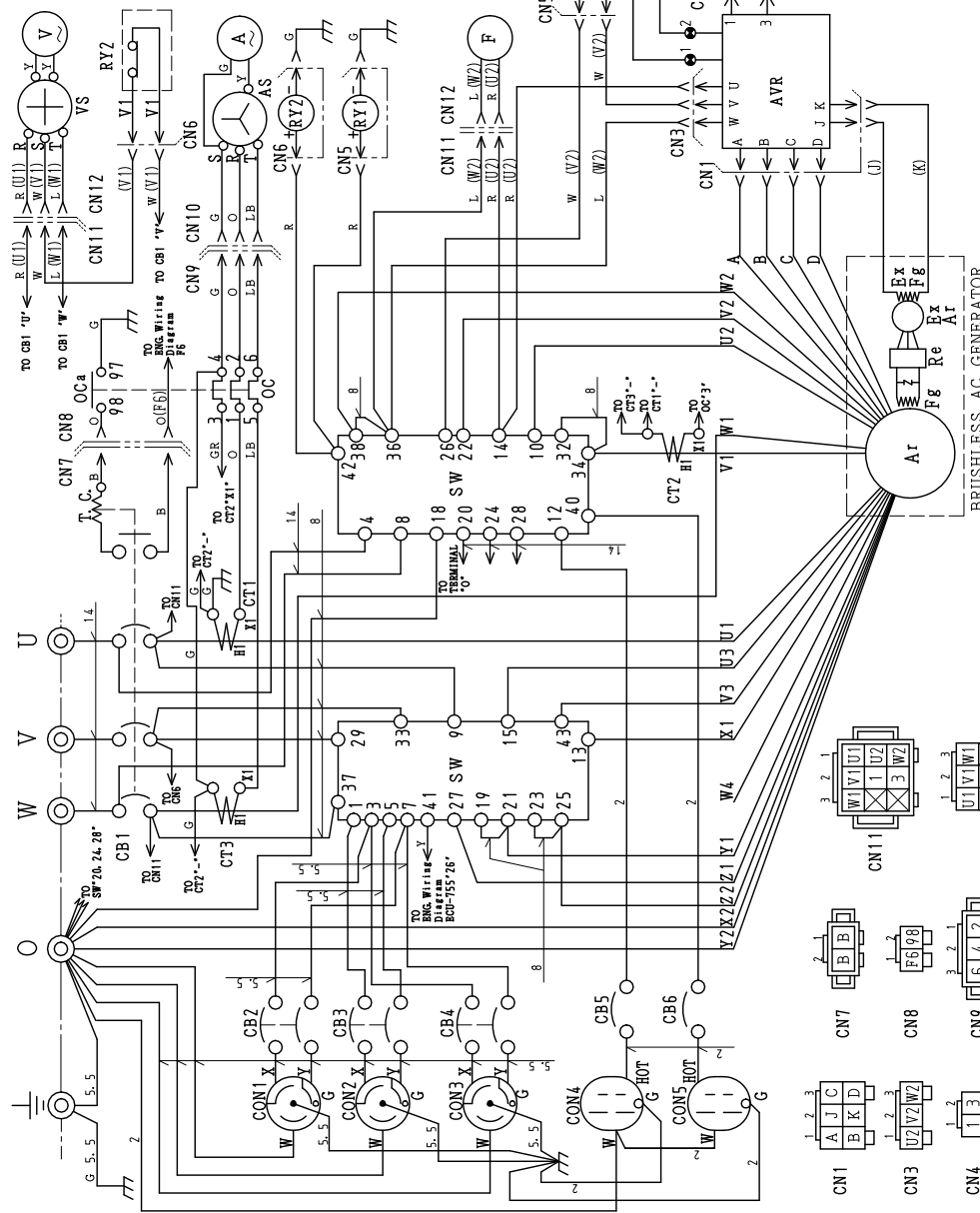

WIRE SIZE	COLOR CODE
14: 1mm <sup>2</sup>	WIRE COLOR
8: 5mm <sup>2</sup>	B BLACK
5.5: 5.5mm <sup>2</sup>	L BLUE
7: 7mm <sup>2</sup>	BR BROWN
	G GREEN
	GR GRAY
	Y YELLOW
	LG LIGHT GREEN
	V VIOLET
	P PINK
	OR ORANGE
	WB WIRE COLOR/LINE COLOR

NOTE: All conductors are 1.25 mm<sup>2</sup> thick with designated color.

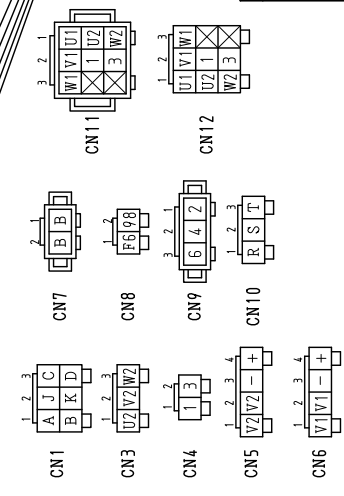

GENERATOR WIRING DIAGRAM NO. M1814000413







# ENGINE WIRING DIAGRAM (M1814100433)

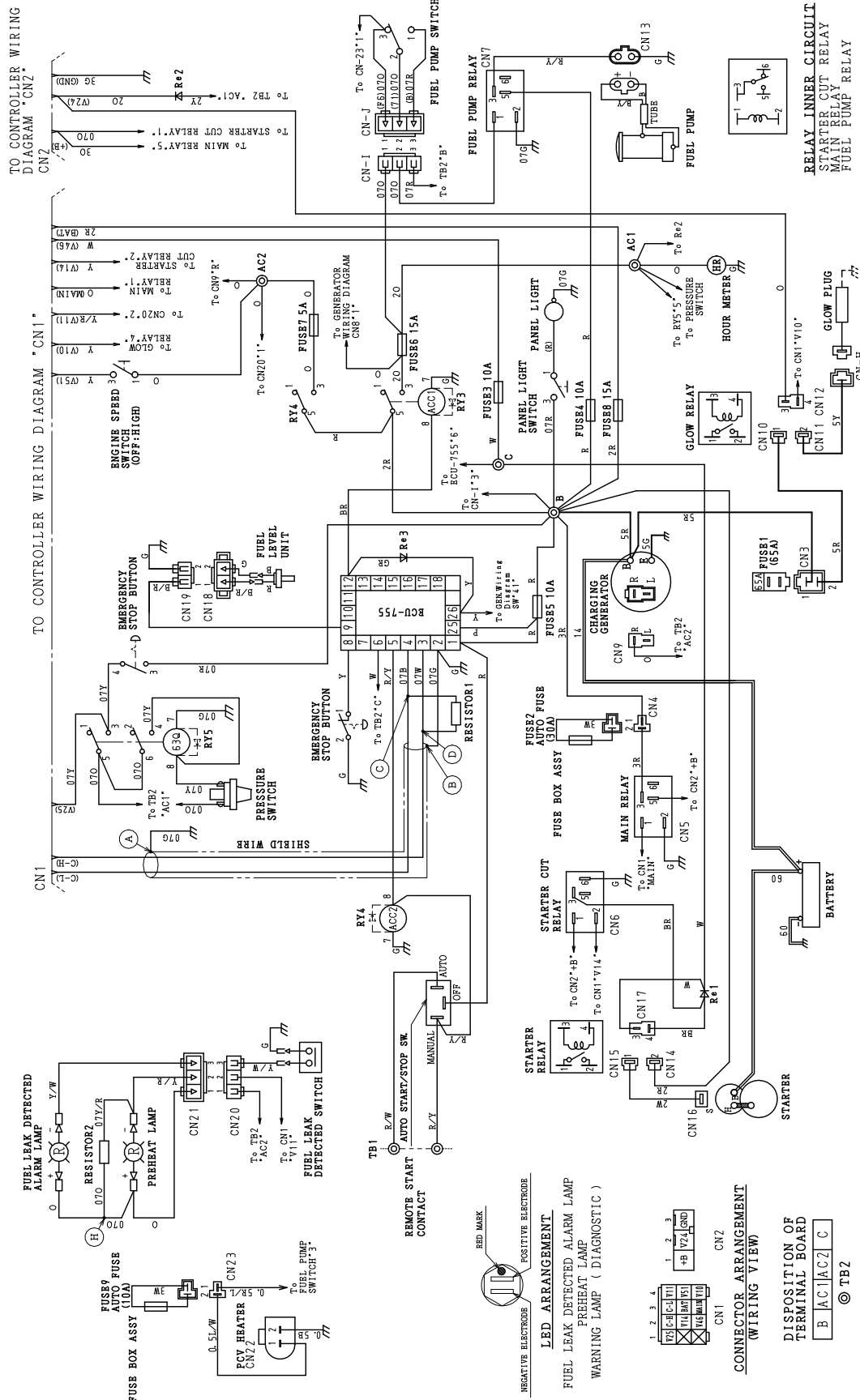

WIRE SIZE		COLOR CODE	
WIRE SIZE	WIRE COLOR	WIRE COLOR	WIRE COLOR
60	mm <sup>2</sup>	B	BLACK
14	mm <sup>2</sup>	R	RED
5	mm <sup>2</sup>	W	WHITE
3	mm <sup>2</sup>	L	BLUE
2	mm <sup>2</sup>	BR	BROWN
0.75	mm <sup>2</sup>	Y	YELLOW
0.5	mm <sup>2</sup>	G	GREEN
		LB	LIGHT BLUE
		LG	LIGHT GREEN
		GR	GRAY
		V	VIOLET
		P	PINK
		O	ORANGE

ENGINE WIRING DIAGRAM NO. M1814100433

TO CONTROLLER WIRING DIAGRAM \*CN2\*  
CNZ

TO CONTROLLER WIRING DIAGRAM \*CN1\*  
CNZ

RELAY INNER CIRCUIT  
STARTER CUT RELAY  
MAIN RELAY  
FUEL PUMP RELAY

FUEL LEAK DETECTED ALARM LAMP

FUSE BOX ASSY (30A)

PCV HEATER

FUEL PUMP SWITCH '3'

REMOTE START CONTACT

STARTER RELAY

STARTER CUT RELAY

FUSE BOX ASSY (30A)

MAIN RELAY

FUEL PUMP RELAY

CHARGING GENERATOR

PANEL LIGHT SWITCH

HOUR METER

GLOW RELAY

GLOW PLUG

BATTERY

STARTER

NEGATIVE ELECTRODE

POSITIVE ELECTRODE

LED ARRANGEMENT

FUEL LEAK DETECTED ALARM LAMP

PREHEAT LAMP

WARNING LAMP (DIAGNOSTIC)

CONNECTOR ARRANGEMENT (WIRING VIEW)

DISPOSITION OF TERMINAL BOARD

© TBZ



# BATTERY CHARGER WIRING DIAGRAM (OPTION)

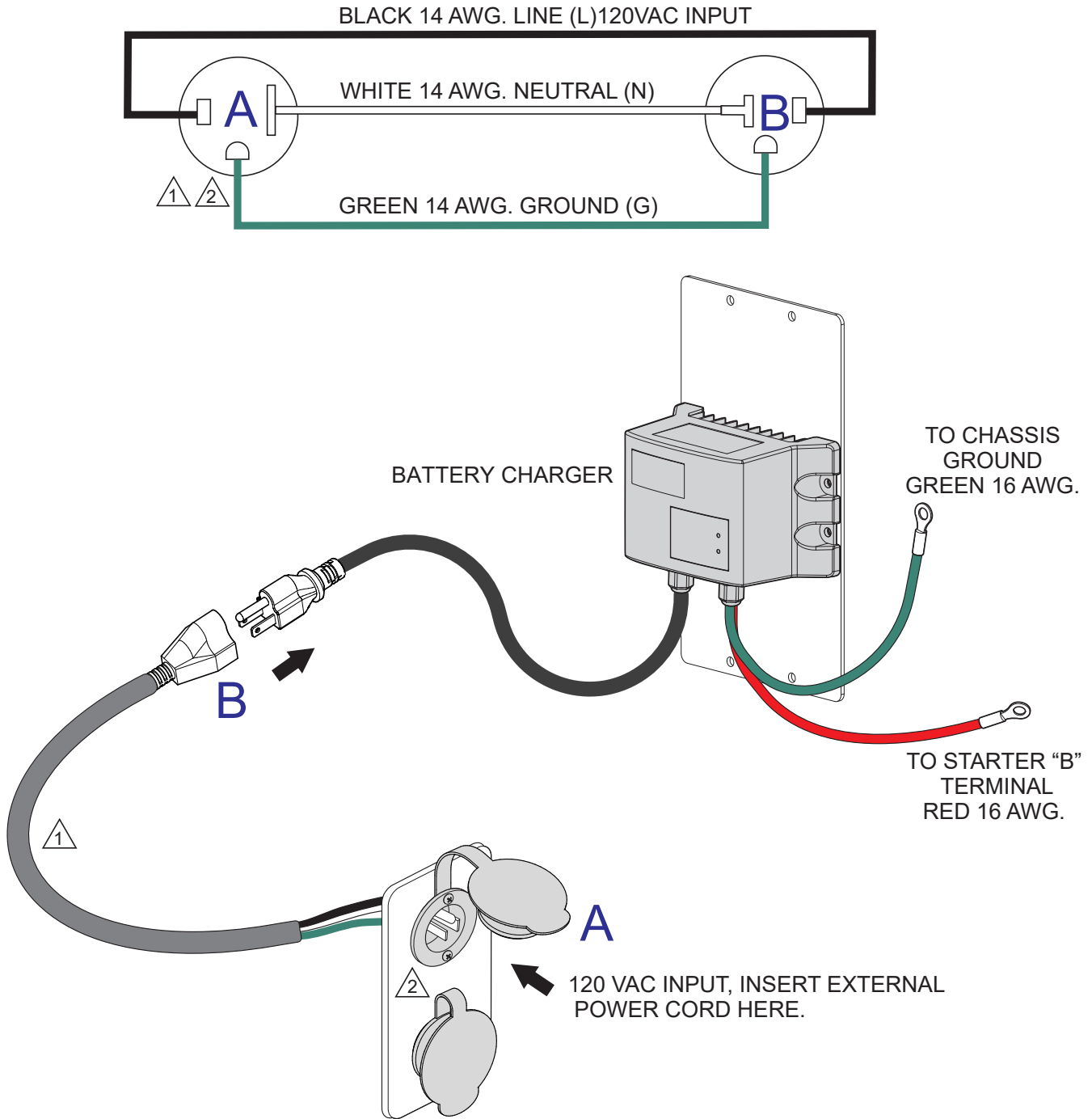

**NOTES:**

- ① INLET RECEPTACLE & CORD, NEMA 5-15P, 15 AMP, 125V, P/N EE62076
- ② RECEPTACLE IS MOUNTED ON OUTPUT TERMINAL PANEL ASSY.

# ENGINE BLOCK HEATER WIRING DIAGRAM (OPTION)

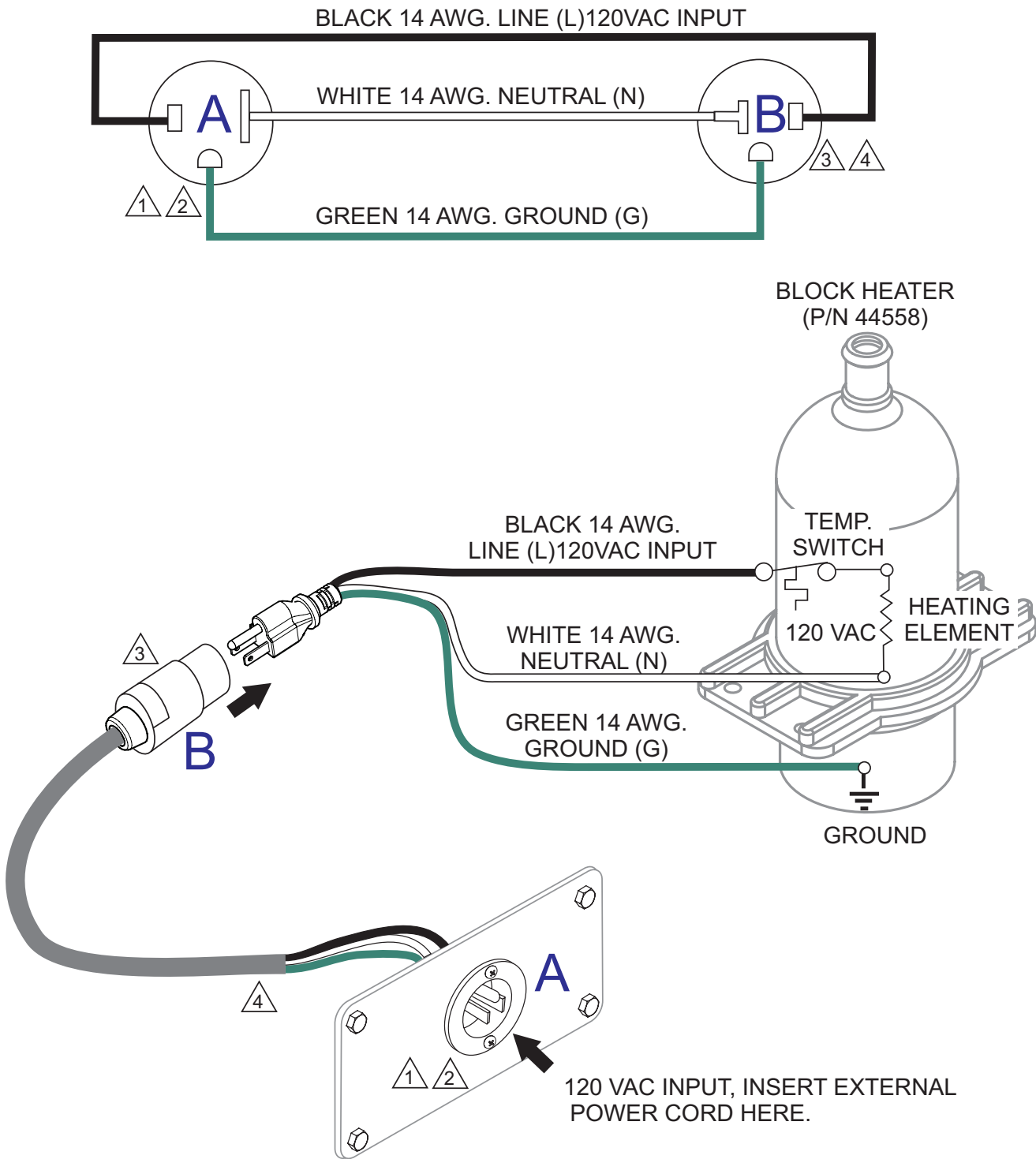

**NOTES:**

- ① NEMA 5-15, 15A, 120 VAC, P/N EE6176 (HBL5278C/HUBBLE RECEPTACLE).
- ② RECEPTACLE IS MOUNTED ON OUTPUT TERMINAL PANEL ASSY.
- ③ 20 AMP, 5-20R RECEPTACLE, P/N EE6131 (HBL5369C/HUBBLE RECEPTACLE).
- ④ CORD, CAROL 3/C 14 AWG., P/N EE56557.



# OPERATION MANUAL

## HERE'S HOW TO GET HELP

PLEASE HAVE THE MODEL AND SERIAL  
NUMBER ON HAND WHEN CALLING

### UNITED STATES

#### *Multiquip Inc.*

(310) 537- 3700  
6141 Katella Avenue Suite 200  
Cypress, CA 90630  
E-MAIL: [mq@multiquip.com](mailto:mq@multiquip.com)  
WEBSITE: [www.multiquip.com](http://www.multiquip.com)

---

### CANADA

#### *Multiquip*

(450) 625-2244  
4110 Industriel Boul.  
Laval, Quebec, Canada H7L 6V3  
E-MAIL: [infocanada@multiquip.com](mailto:infocanada@multiquip.com)

### UNITED KINGDOM

#### *Multiquip (UK) Limited Head Office*

0161 339 2223  
Unit 2, Northpoint Industrial Estate, Globe Lane,  
Dukinfield, Cheshire SK16 4UJ  
E-MAIL: [sales@multiquip.co.uk](mailto:sales@multiquip.co.uk)

© COPYRIGHT 2025, MULTIQUIP INC.

Multiquip Inc., the MQ logo and the MQ Power logo are registered trademarks of Multiquip Inc. and may not be used, reproduced, or altered without written permission. All other trademarks are the property of their respective owners and used with permission.

This manual MUST accompany the equipment at all times. This manual is considered a permanent part of the equipment and should remain with the unit if resold.

The information and specifications included in this publication were in effect at the time of approval for printing. Illustrations, descriptions, references and technical data contained in this manual are for guidance only and may not be considered as binding. Multiquip Inc. reserves the right to discontinue or change specifications, design or the information published in this publication at any time without notice and without incurring any obligations.

Manufactured for  
MQ Power Inc.  
by  
DENYO MANUFACTURING CORP.

