



# DCA45SSIU4FC8

## Generator

### WhisperWatt™

Prime Rating — 36 kW (45 kVA)

Standby Rating — 40 kW (50 kVA)

Three-Phase, 60 Hertz, 0.8 PF

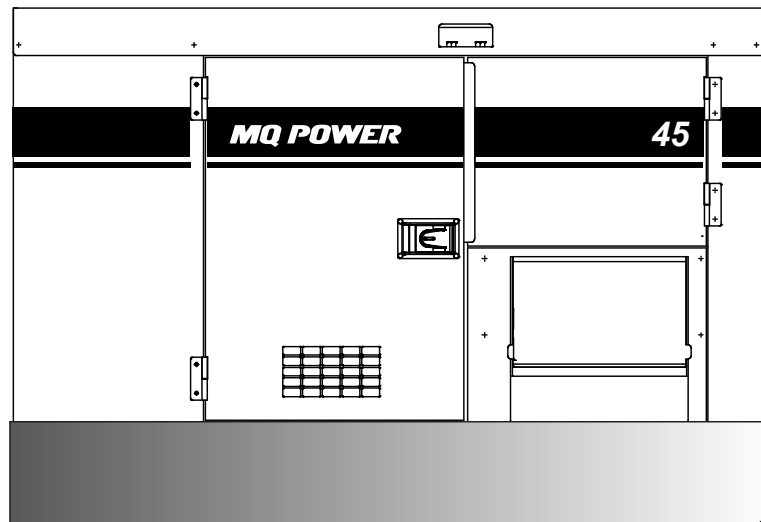

#### STANDARD FEATURES

- Heavy duty, 4-cycle, direct injection, heated crankcase vent, turbocharged, charge air cooled, diesel engine provides maximum reliability.
- EPA emissions certified — Tier 4 Final emissions compliant.
- Microprocessor engine control system maintains frequency to  $\pm 0.25\%$ .
- Full load acceptance of standby nameplate rating in a single step.
- Fuel/water separator removes condensation from fuel for extended engine life. Panel-mounted alarm light included.
- Sound attenuated, weather resistant, steel housing provides operation at 66 dB(A) at 23 feet. Fully lockable enclosure allows safe unattended operation.
- E-coat and powder coat paint provide durability and weather protection.
- Internal B138 compliant fuel tank with direct reading fuel gauge.
- Spill containment — Captures all engine oil and coolant.
- Brushless alternator reduces service and maintenance requirements and meets temperature rise standards for Class H insulation systems.
  - Open delta alternator design provides virtually unlimited excitation for maximum motor starting capability.
  - Automatic voltage regulator (AVR) provides precise regulation.
- Fully covered power panel. Three-phase terminals and single phase receptacles allow fast and convenient hookup for most applications including temporary power boxes, tools and lighting equipment. The GFCI receptacles are NEMA 5-20, and the auxiliary outputs use CS6369 twist-lock receptacles.
- ECU754 microprocessor-based digital generator controller.
  - Remote 2-wire start/stop control.
  - Operational temperature range of  $-40^{\circ}$  to  $85^{\circ}$  C.
- Digital engine gauges including oil pressure, water temperature, battery volts, engine speed and fuel level.
- Analog generator instrumentation including AC ammeter, AC voltmeter, frequency meter, ammeter phase selector switch, voltmeter phase selector switch, and voltage regulator adjustment potentiometer.
- Automatic safety shutdown system monitors the water temperature, low coolant, engine oil pressure, overspeed, and overcrank. Warning lights indicate abnormal conditions.
- Emergency Stop Switch — when manually activated shuts down generator in the event of an emergency.



# DCA45SSIU4FC8

## Generator

### SPECIFICATIONS

Generator Specifications		
Design	Revolving field, self-ventilated Drip-proof, single bearing	
Armature Connection	Star with Neutral	Zig Zag
Phase	3	Single
Standby Output	40 KW (50 KVA)	28.8 KW
Prime Output	36 KW (45 KVA)	26 KW
3Ø Voltage (L-L/L-N) Voltage Selector Switch at 3Ø 240/139	208Y/120, 220Y/127, 240Y/139	N/A
3Ø Voltage (L-L/L-N) Voltage Selector Switch at 3Ø 480/277	416Y/240, 440Y/254, 480Y/277	N/A
1Ø Voltage (L-L/L-N) (Voltage Selector Switch at 1Ø 240/120)	N/A	240/120
Power Factor	0.8	1.0
Voltage Regulation (No load to full load)	±0.5%	
Generator RPM	1800	
Frequency	60 Hz	
Winding Pitch	2/3	
No. of Poles	4	
Excitation	Brushless with AVR	
Frequency Regulation: No Load to Full Load	Isochronous under varying loads from no load to 100% rated load	
Frequency Regulation: Steady State	±0.25% of mean value for constant loads from no load to full load.	
Insulation	Class H	
Sound Level dB(A) Full load at 23 feet	66	

Engine Specifications	
Make / Model	Isuzu / 4LE2X
Emissions	EPA Tier 4 Final Certified
Starting System	Electric
Design	4-cycle, water cooled, direct injection, turbocharged, charge air cooled and EGR
Displacement	133.0 in <sup>3</sup> (2179 cc)
No. cylinders	4
Bore x Stroke (mm)	85 x 96
Gross Engine Power Output	65.7 hp (49 kW)
BMEP	217 psi (1499 kPa)
Piston Speed	1133.9 ft./min. (5.76 m/s)
Compression Ratio	17.6:1
Engine Speed	1800 rpm
Overspeed Limit	2070 rpm
Oil Capacity	3.2 gallons (12.2 liters)
Battery	12V 72Ah x 1 ( Group 27. CCA 800A)

Fuel System		
Recommended Fuel	ASTM-D975-No.1 & No.2-D*	
Maximum Fuel Flow (per hour)	3.4 gallons (13 liters)	
Maximum Inlet Restriction (Hg)	11 in. (280 mm)	
Fuel Tank Capacity	86 gallons (327 liters)	
Fuel Consumption	gph	lph
At full load	2.93	11.1
At 3/4 load	2.20	8.31
At 1/2 load	1.60	6.04
At 1/4 load	1.04	3.92

\* Use Ultra-low sulfur diesel fuel

Cooling System	
Fan Load	2.01 hp (1.5 kW)
Coolant Capacity (with radiator)	4.44 gallons (16.8 liters)
Coolant Flow Rate (per minute)	16.9 gallons (64.2 liters)
Heat Rejection to Coolant (per minute)	1934 Btu (2.04 MJ)
Maximum Coolant Friction Head	14.5 psi (100 kPa)
Maximum Coolant Static Head	3.35 feet (1.04 meters)
Ambient Temperature Rating	104°F (40°C)

Air	
Combustion Air	174 cfm (4.94 m <sup>3</sup> /min)
Maximum Air Cleaner Restriction	25 in. H <sub>2</sub> O (6.23 kPa)
Alternator Cooling Air	526 cfm (14.9 m <sup>3</sup> /min)
Radiator Cooling Air	1900 cfm (53.8 m <sup>3</sup> /min)
Minimum Air Opening to Room	3.5 ft <sup>2</sup> (0.33 m <sup>2</sup> )
Minimum Discharge Opening	2.27 ft <sup>2</sup> (0.21 m <sup>2</sup> )

Exhaust System	
Gas Flow (full load)	237 cfm (6.7 m <sup>3</sup> /min)
Gas Temperature	1078°F (581°C)
Maximum Back Pressure	38.1 in. H <sub>2</sub> O (9.5 kPa)

Amperage	
Rated Voltage	Maximum Amps
1Ø 120 Volt	100 Amps (4 wire), 108A x 2 (Zigzag)
1Ø 240 Volt	50 Amps (4 wire), 108A (Zigzag)
3Ø 240 Volt	108 Amps
3Ø 480 Volt	54 Amps
Main Line Circuit Breaker Rating	125 Amps
Over Current Relay Trip Set Point 480V Mode Only	54 Amps

### WARRANTY\*

#### Isuzu Engine\*\*

12 months from date of purchase with unlimited hours or 36 months from date of purchase with 3,000 hours (whichever comes first).

#### Generator

24 months from date of purchase or 2,000 hours (whichever occurs first).

#### Trailer

12 months excluding normal wear items.

\*Refer to the express written, one-year limited warranty sheet for additional information.

\*\*Refer to Isuzu Diesel Engine Limited Warranty for details.

### NOTICE

Specifications sheet is subject to change and is not intended for use in installation design.



# DCA45SSIU4FC8

## Generator

### MQ POWER DECIBEL LEVELS

Our soundproof housing allows substantially lower operating noise levels than competitive designs. WhisperWatts are at home on construction sites, in residential neighborhoods, and at hospitals — just about anywhere.

- 90 — Subway / truck traffic
- 80 — Average city traffic
- 70 — Inside car at 60 mph
- 60 — Air conditioner at 20 feet
- 50 — Normal conversation

**WhisperWatt at 23 feet**



### GENERATOR OUTPUT PANEL

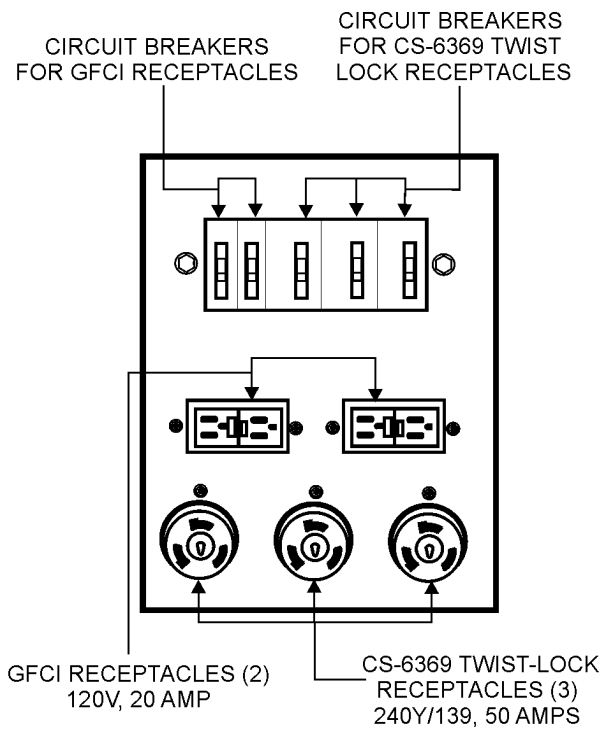

### OPTIONAL GENERATOR FEATURES

- **PowerBalance™** — designed to assist generators when operating under low temperature and/or low load conditions to insure peak performance.
- **Battery Charger** — provides fully automatic and self-adjusting charging to the generator's battery system.
- **Low Coolant Level Shutdown** — provides protection from critically low coolant levels. Includes control panel warning light.
- **Trailer Mounted Package** — meets National Highway Traffic Safety Administration (NHTSA) regulations. Trailer is equipped with electronic or surge brakes with double or triple axle configuration.

### OPTIONAL CONTROL FEATURES

- **Audible Alarm** — alerts operator of abnormal conditions.

### OPTIONAL OUTPUT CONNECTIONS

- **Cam-Lok Connectors** — provides quick disconnect alternative to bolt-on connectors.
- **Pin and Sleeve Connectors** — provides industry standard connectors for all voltage requirements.
- **Output Cable** — available in any custom length and size configuration.



# DCA45SSIU4FC8

## Generator

### SKID-MOUNT DIMENSIONS

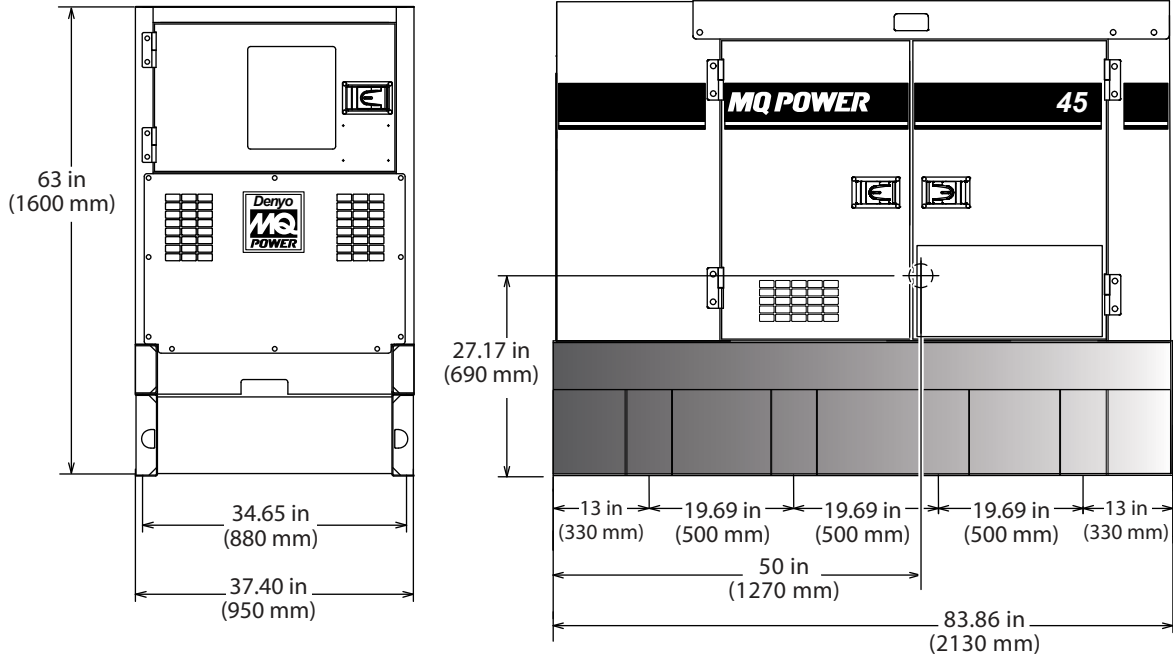

### TRAILER-MOUNT DIMENSIONS

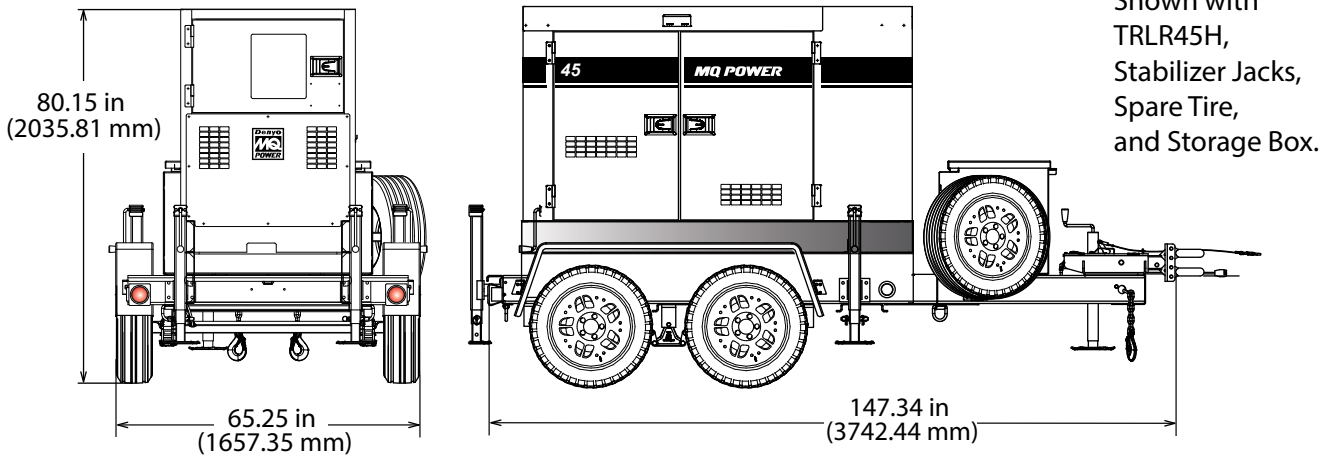

#### DCA45SSI4FC8 Weights\*

Dry Weight	2,425 lbs. (1100 kg)
Wet Weight	3,152 lbs (1430 kg)
Max. Lifting Point Capacity	6,960 lbs. (3,157 kg)

#### DCA45SSI4FC8 and TRLR45 Weights\*

Dry Weight (with TRLR45)	3,443 lbs. (1,562 kg)
Wet Weight (with TRLR45)	4,170 lbs. (1,892 kg)

\* Weights do not include options.

Generator can be placed on MQ Trailer Models TRLR45 and TRLR75XF2.

#### NOTICE

Features and Specifications are subject to change without notice.



**MULTIQUIP**  
 6141 Katella Avenue Suite 200  
 Cypress, CA 90630  
 310-537-3700  
 E-MAIL: [mq@multiquip.com](mailto:mq@multiquip.com)  
 WEBSITE: [www.multiquip.com](http://www.multiquip.com)