



# DCA45USIXF

## MQ POWER Series Generator

### WhisperWatt™

Prime Rating — 36 kW (45 kVA)

Standby Rating — 40 kW (50 kVA)

60 Hertz

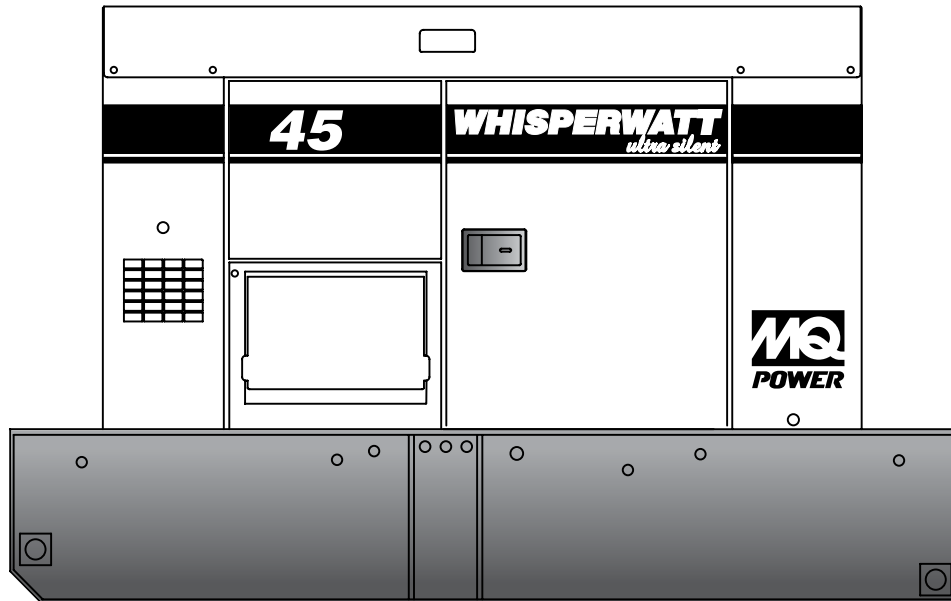

#### STANDARD FEATURES

- Heavy duty, 4-cycle, direct injection, diesel engine provides maximum reliability.
- Brushless alternator reduces service and maintenance requirements and meets temperature rise standards for Class H insulation systems.
- Open delta excitation design provides virtually unlimited excitation for maximum motor starting capability.
- Automatic voltage regulator (AVR) provides precise regulation.
- Electronic Governor Control (Crystal Sync) — maintains frequency to within  $\pm 0.25\%$  from no load to full load.
- Full load acceptance of standby nameplate rating in one step (NFPA 110, para 5-13.2.6).
- Sound attenuated, weather resistant, steel housing provides operation at 58 dB(A) at 23 feet. Fully lockable enclosure allows safe unattended operation.
- Internal fuel tank with direct reading of fuel gauge.
- Seven stage powder coat paint system provides durability and weather protection.
- Fuel/water separator removes condensation from fuel for extended engine life. Panel mounted alarm light included.
- Complete engine analog instrumentation includes DC ammeter, oil pressure gauge, water temp. gauge, fuel level gauge, tachometer/hour meter, preheat indicator, emergency shutdown monitors, and keyed start switch.
- Automatic start/stop control — automatically starts the generator set during a commercial power failure when used in conjunction with a transfer switch.
- Complete generator analog instrumentation includes voltage regulator control, ammeter phase selector switch, voltmeter phase selector switch, AC voltmeter, AC ammeter, frequency meter, panel light, and circuit breaker.
- Automatic safety shutdown system monitors the water temperature, engine oil pressure, overspeed and overcrank. Warning lights indicate abnormal conditions.
- Complete power panel. Fully covered; three-phase terminals and single phase receptacles allow fast and convenient hookup for most applications including temporary power boxes, tools and lighting equipment. All are NEMA standard.
- Simultaneous single and three phase power.
- Voltage selector switch allows easy to change voltages as your applications require.
- EPA emissions certified - Interim Tier 4 emissions compliant.



# DCA45USIXF

## MQ POWER Series Generator

### SPECIFICATIONS

Generator Specifications	
Design	Revolving field, self-ventilated Drip-proof, single bearing
Armature Connection	Star with Neutral/Zig Zag
Standby Output	40 KW (50 KVA)
Prime Output	36 KW (45 KVA)
Voltage — 3Ø	208, 220, 240, 416, 440, 480V Switchable
Voltage — 1Ø	120, 127, 139, 240, 254, 277V Switchable
Power Factor	0.8
Voltage Regulation (No load to full load)	±0.5%
Generator RPM	1800
Frequency	60 Hz
No. of Poles	4
Excitation	Brushless with AVR
Frequency	60 Hz
Frequency Regulation: No Load to Full Load	Isochronous under varying loads from no load to 100% rated load
Frequency Regulation: Steady State	±0.25% of mean value for constant loads from no load to full load.
Insulation	Class H
Sound Level dB(A) Full load at 23 feet	58

Engine Specifications	
Make / Model	Isuzu / BU-4JJ1T
Emissions	EPA Interim Tier 4 Certified
Starting System	Electric
Design	4-cycle, water cooled, direct injection, turbocharged
Displacement	183.0 in <sup>3</sup> (2999 cc)
No. cylinders	4
Bore x Stroke (mm)	95.4 x 104.9
Gross Engine Power Output	67.1 bhp (50 kW)
BMEP	137 psi (947 kPa)
Piston Speed	1237 ft./min. (6.29 m/s)
Compression Ratio	17.5:1
Engine Speed	1800 rpm
Overspeed Limit	2100 rpm
Oil Capacity	3.96 gallons (15 liters)
Battery	12V 72Ah x 1

Fuel System		
Recommended Fuel	ASTM-D975-No.1 & No.2-D	
Maximum Fuel Flow (per hour)	16 gallons (61 liters)	
Maximum Inlet Restriction (Hg)	5.9 in. (150 mm)	
Fuel Tank Capacity	198 gallons (751 liters)	
<b>Fuel Consumption</b>	<b>gph</b>	<b>lph</b>
At full load	2.7	10.4
At 3/4 load	2.1	8.0
At 1/2 load	1.5	5.7
At 1/4 load	0.95	3.6

Cooling System	
Fan Load	0.54 hp (0.4 kW)
Coolant Capacity (with radiator)	3.15 gallons (12 liters)
Coolant Flow Rate (per minute)	15.4 gallons (58.5 liters)
Heat Rejection to Coolant (per minute)	1640 Btu (1.73 MJ)
Maximum Coolant Friction Head	6.1 psi (42 kPa)
Maximum Coolant Static Head	21 feet (6.4 meters)
Ambient Temperature Rating	104°F (40°C)

Air	
Combustion Air	99 cfm (2.8 m <sup>3</sup> /min)
Maximum Air Cleaner Restriction	25 in. H <sub>2</sub> O (6.25 kPa)
Alternator Cooling Air	526 cfm (14.9 m <sup>3</sup> /min)
Radiator Cooling Air	1472 cfm (41.7 m <sup>3</sup> /min)

Exhaust System	
Gas Flow (full load)	233 cfm (6.6 m <sup>3</sup> /min)
Gas Temperature	860°F (460°C)
Maximum Back Pressure	53.2 in. H <sub>2</sub> O (13.3 kPa)

Amperage	
Rated Voltage	Maximum Amps
1Ø 120 Volt	100 Amps (4 wire)
1Ø 240 Volt	50 Amps (4 wire)
3Ø 240 Volt	108 Amps
3Ø 480 Volt	54 Amps
Main Line Circuit Breaker Rating	110Amps
Over Current Relay Trip Set Point	54 Amps

### WARRANTY\*

#### Isuzu Engine

12 months from date of purchase with unlimited hours or 24 months from date of purchase with 2000 hours (whichever comes first).

#### Generator

24 months from date of purchase or 2000 hours (whichever occurs first).

#### Trailer

12 months excluding normal wear items.

\*Refer to the express written, one-year limited warranty sheet for additional information.

### NOTICE

Generator is not intended for use in enclosed areas or where free flow of air is restricted.

Backfeed to a utility system can cause electrocution, shock and/or property damage. **DO NOT** connect to any building's electrical system except through an approved device.

Specifications are subject to change without notice.



# DCA45USIXF

## MQ POWER Series Generator

### MQ POWER DECIBEL LEVELS

Our soundproof housing allows substantially lower operating noise levels than competitive designs. WhisperWatts are at home on construction sites, in residential neighborhoods, and at hospitals — just about anywhere.

- 90 — Subway / truck traffic
- 80 — Average city traffic
- 70 — Inside car at 60 mph
- 60 — Air conditioner at 20 feet  
**Ultra-Silent at 23 feet**
- 50 — Normal conversation



### ULTRA-SILENT FEATURES

- **Low Noise Muffler** — Large capacity low noise muffler minimizes exhaust sound.
- **Soundproof Casing** — The new design divides the cabinet into three sections, separating the engine, muffler and radiator for more efficient cooling and reduces noise from the engine and fans.
- **New Cooling System** — An advanced design uses two separate air intake systems to cool the generator. The engine fan draws air in to cool the engine and generator housing while a second electric fan directly cools the radiator. With less air being drawn into the generator through each fan, considerably less noise is produced through the top of the generator.
- **Environmental Design** — Constructed using an integrated environmental skid and fuel tank. This design fully contains fuel leakage and any liquid that might leak from the engine such as lube oil or radiator coolant. All potentially hazardous liquids are contained without contaminating the surrounding area.

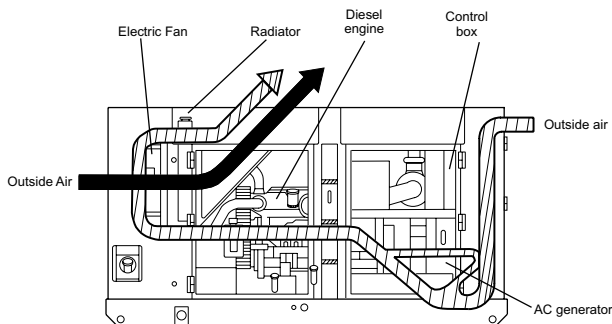

Flow of Cooling Air

### GENERATOR OUTPUT PANEL

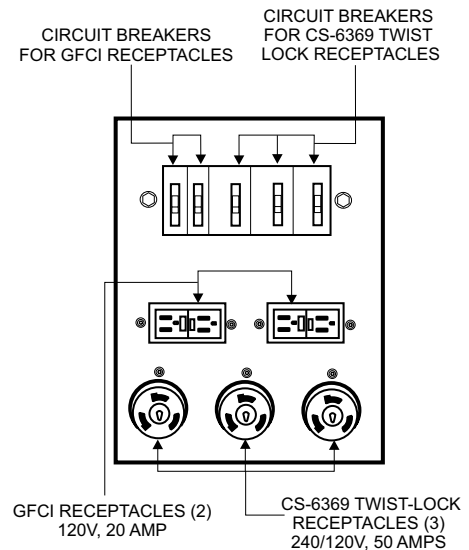

### OPTIONAL GENERATOR FEATURES

- **Battery Charger** — provides fully automatic and self-adjusting charging to the generator's battery system.
- **Jacket Water Heater** — for easy starting in cold weather climates.
- **Special Batteries** — long life batteries provide extra engine cranking power.
- **Low Coolant Level Shutdown** — provides protection from critically low coolant levels. Includes control panel warning light.
- **Spring Isolators** — provides extra vibration protection for standby applications.
- **Trailer Mounted Package** — meets National Highway Traffic Safety Administration (NHTSA) regulations. Trailer is equipped with electric or surge-hydraulic brakes with double or triple axle configuration.

### OPTIONAL CONTROL FEATURES

- **Emergency Stop Switch** — when manually activated shuts down generator in the event of an emergency.

- **Audible alarm** — alerts operator of abnormal conditions.

### OPTIONAL OUTPUT CONNECTIONS

- **Cam-Lok Connectors** — provides quick disconnect alternative to bolt-on connectors.
- **Pin and Sleeve Connectors** — provides industry standard connectors for all voltage requirements.
- **Output Cable** — available in any custom length and size configuration.



# DCA45USIXF

## MQ POWER Series Generator

### DIMENSIONS

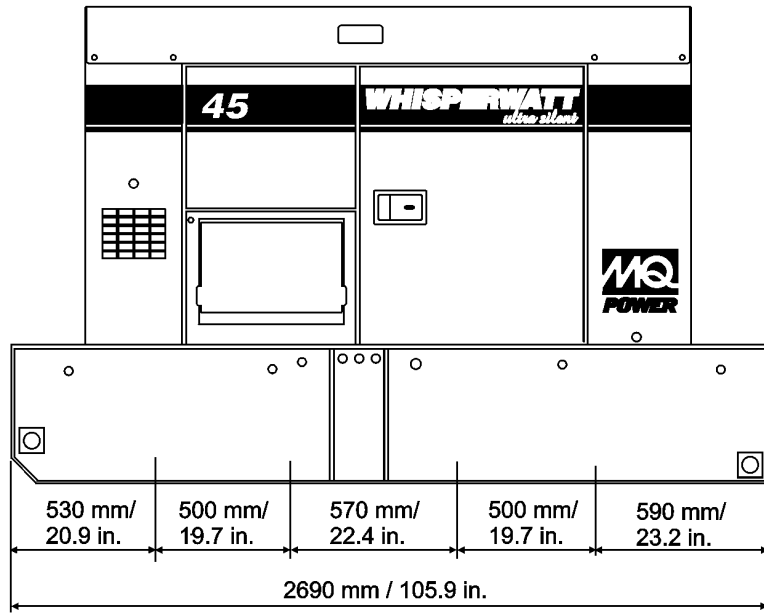
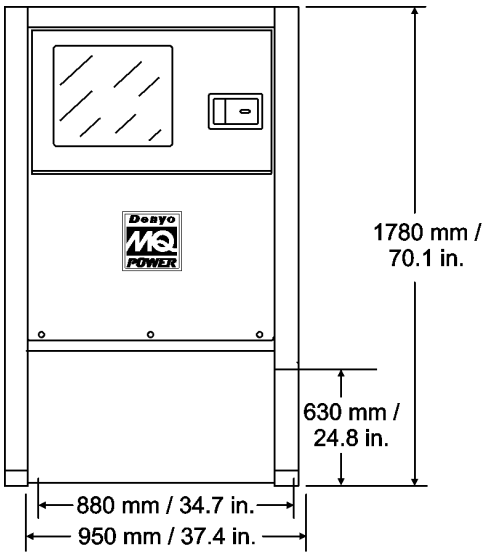

Weight	
Dry Weight	3,749 lbs. (1,700 kg)
Wet Weight	5,182 lbs. (2,350 kg)
Max. Lifting Point Capacity	6,960 lbs. (3,157 kg)

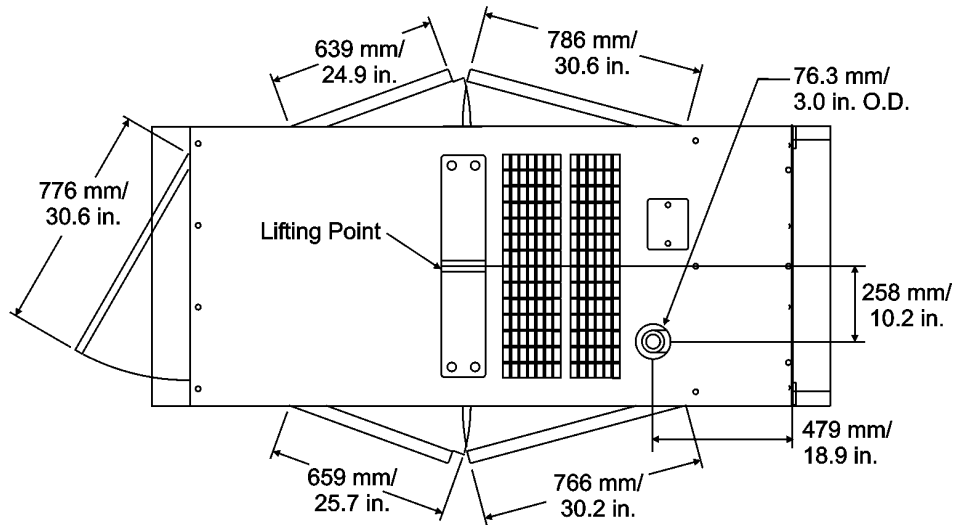

Manufactured by Denyo Co.

Your MultiQuip dealer is:

© COPYRIGHT 2015 MULTIQUIP INC.  
DCA45USIXF Rev. #10 (01/13/15)



MULTIQUIP  
POST OFFICE BOX 6254  
CARSON, CA 90749  
310-537-3700 • 800-883-2551  
FAX: 310-604-3831  
E-MAIL: sales@multiquip.com  
WEBSITE: www.multiquip.com