

PARTS MANUAL



WHISPERWATT™ SERIES MODEL DCA800SSK2 60HZ GENERATOR (STD.) (KOMATSU SAA6D170E-3 DIESEL ENGINE)

PARTS LIST NO. C5871301004

Revision #2 (09/09/24)

To find the latest revision of this publication or associated operation manual, visit our website at: www.mqpower.com



THIS MANUAL MUST ACCOMPANY THE EQUIPMENT AT ALL TIMES.

**DCA800SSK2
60 Hz Generator**

Explanation Of Code In Remarks Column..... 4
Suggested Spare Parts 5

Component Drawings

Generator Assembly 6–9
Control Panel Assembly 10–11
Control Box Assembly 12–15
Engine Assembly 16–19
Radiator Assembly (S/N 316346 AND ABOVE) ... 20–21
Alternator Assembly (S/N 311209 AND ABOVE) . 22–23
Thermostat Assembly (S/N 316346 AND ABOVE) . 24–25
Water Pump Assembly 26–27
Starter Assembly (S/N 316346 AND ABOVE).... 28–29
Engine Operating Panel Assembly 30–31
Output Terminal Assembly 32–35
Battery Assembly 36–37
Muffler Assembly 38–39
Fuel Tank Assembly 40–41
Enclosure Assembly #1 42–45
Enclosure Assembly #2 46–49
Enclosure Assembly #3 50–53
Rubber Seals Assembly 54–55
Nameplate And Decals Assembly #1..... 56–59
Nameplate And Decals Assembly #2..... 60–61

NOTICE
Part numbers are subject to change without notice.

EXPLANATION OF CODE IN REMARKS COLUMN

The following section explains the different symbols and remarks used in the Parts section of this manual. Use the help numbers found on the back page of the manual if there are any questions.

NOTICE

The contents and part numbers listed in the parts section are subject to change **without notice**. Multiquip does not guarantee the availability of the parts listed.

SAMPLE PARTS LIST

NO.	PART NO.	PART NAME	QTY.	REMARKS
1	12345	BOLT.....	1	INCLUDES ITEMS W/%
2%		WASHER, 1/4 IN.....		NOT SOLD SEPARATELY
2%	12347	WASHER, 3/8 IN....	1	MQ-45T ONLY
3	12348	HOSE	A/R	MAKE LOCALLY
4	12349	BEARING	1	S/N 2345B AND ABOVE

NO. Column

Unique Symbols — All items with same unique symbol

(@, #, +, %, or >) in the number column belong to the same assembly or kit, which is indicated by a note in the “Remarks” column.

Duplicate Item Numbers — Duplicate numbers indicate multiple part numbers, which are in effect for the same general item, such as different size saw blade guards in use or a part that has been updated on newer versions of the same machine.

NOTICE

When ordering a part that has more than one item number listed, check the remarks column for help in determining the proper part to order.

PART NO. Column

Numbers Used — Part numbers can be indicated by a number, a blank entry, or TBD.

TBD (To Be Determined) is generally used to show a part that has not been assigned a formal part number at the time of publication.

A blank entry generally indicates that the item is not sold separately or is not sold by Multiquip. Other entries will be clarified in the “Remarks” Column.

QTY. Column

Numbers Used — Item quantity can be indicated by a number, a blank entry, or A/R.

A/R (As Required) is generally used for hoses or other parts that are sold in bulk and cut to length.

A blank entry generally indicates that the item is not sold separately. Other entries will be clarified in the “Remarks” Column.

REMARKS Column

Some of the most common notes found in the “Remarks” Column are listed below. Other additional notes needed to describe the item can also be shown.

Assembly/Kit — All items on the parts list with the same unique symbol will be included when this item is purchased.

Indicated by:
 “INCLUDES ITEMS W/(unique symbol)”

Serial Number Break — Used to list an effective serial number range where a particular part is used.

Indicated by:
 “S/N XXXXX AND BELOW”
 “S/N XXXX AND ABOVE”
 “S/N XXXX TO S/N XXX”

Specific Model Number Use — Indicates that the part is used only with the specific model number or model number variant listed. It can also be used to show a part is NOT used on a specific model or model number variant.

Indicated by:
 “XXXXX ONLY”
 “NOT USED ON XXXX”

“Make/Obtain Locally” — Indicates that the part can be purchased at any hardware shop or made out of available items. Examples include battery cables, shims, and certain washers and nuts.

“Not Sold Separately” — Indicates that an item cannot be purchased as a separate item and is either part of an assembly/kit that can be purchased, or is not available for sale through Multiquip.

SUGGESTED SPARE PARTS

DCA800SSK2 WHISPERWATT GENERATOR WITH KOMATSU SAA6D170E3 DIESEL ENGINE

1 to 3 units

Qty.	P/N	Description
12.....	0602046653.....	AIR FILTER, ELEMENT, OUTER
6.....	0602046653-1	AIR FILTER, ELEMENT, INNER
12.....	6003193320.....	FUEL FILTER, ENGINE
24.....	6002111231	CARTRIDGE OIL FILTER
6.....	6004111171	CARTRIDGE, CORROSION RESISTOR
6.....	0810105400.....	FUEL FILTER, FUEL TANK
2.....	6240613821.....	FAN BELT, ENGINE
2.....	6240816180.....	ALTERNATOR BELT, ENGINE
4.....	6162144810.....	RADIATOR HOSE (UPPER)
1.....	6240611950.....	RADIATOR HOSE (UPPER-INNER)
1.....	6162639651.....	RADIATOR HOSE (LOWER)
1.....	1140348160.....	CAP, RADIATOR
1.....	0601820625.....	AUTOMATIC VOLTAGE REGULATOR
3.....	0601808804.....	CIRCUIT BREAKER, 50 AMP
1.....	0601840073.....	RHEOSTAT, (VOLTAGE REGULATOR)
2.....	0601840100.....	KNOB, RHEOSTAT
1.....	0601810072.....	PILOT LAMP
2.....	0601810261.....	BULB, PILOT LAMP
1.....	0602122272.....	UNIT, OIL PRESSURE, FOR GAUGE
1.....	0602123267.....	UNIT, WATER TEMPERATURE, FOR GAUGE
1.....	0601810261.....	CIRCUIT BREAKER BULB, ON/OFF LAMP
1.....	0601802149.....	FUSE, 10 AMP
1.....	6008158280.....	SWITCH, OIL PRESSURE
1.....	6216849140.....	SENSOR ASSY., COOLANT TEMPERATURE

NOTICE

Part number on this Suggested Spare Parts list may supersede/replace the P/N shown in the text pages of this book.

GENERATOR ASSY.

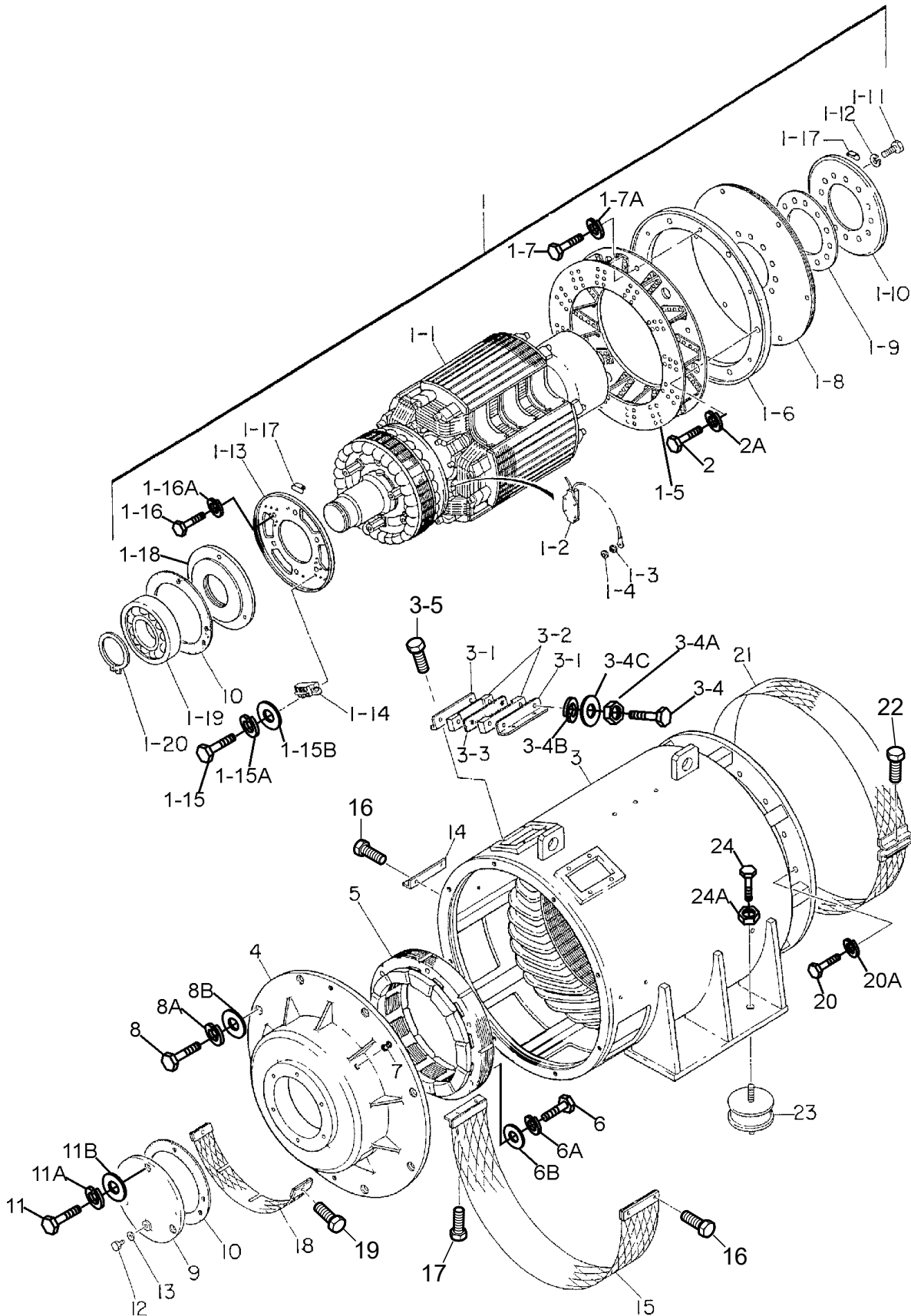

GENERATOR ASSY.

<u>NO.</u>	<u>PART NO.</u>	<u>PART NAME</u>	<u>QTY.</u>	<u>REMARKS</u>
1	C5110000402	ROTOR ASSY.....	1.....	INCLUDES ITEM W/#
1-1#		FIELD ASSY.	1	
1-2#	0601842366	RESISTOR, 80W 50K Ω	4	
1-3#	8171020004	INSULATOR WASHER	6	
1-4#	8171020504	INSULATOR WASHER	6	
1-5#	C5111100002	FAN	1	
1-6#	C5163400003	COUPLING RING	1	
1-7#	0010312025	HEX HEAD BOLT	2	
1-7A#	0042512000	WASHER, LOCK	2	
1-8#	C5163100104	COUPLING DISK ASSY.	1	
1-9#	C5163200004	COUPLING HUB WASHER	1	
1-10#	C5111300003	BALANCING PLATE.....	1.....	PURCHASE ITEM 1-17 AS A SET
1-11#	0012724060	HEX HEAD BOLT	10	
1-12#	0042524000	WASHER, LOCK	10	
1-13#	8461026023	RECTIFIER SET PLATE.....	1.....	PURCHASE ITEM1-17 AS A SET
1-14#	0601823282	RECTIFIER	2	
1-15#	0018205020	HEX SOCKET HEAD CAP SCREW	4	
1-15A#	0040005000	WASHER, LOCK	4	
1-15B#	0041205000	WASHER, FLAT	4	
1-16#	0010112020	HEX HEAD BOLT	6	
1-16A#	0040012000	WASHER, LOCK	6	
1-17#	0601000209	BALANCING WEIGHT KIT	1	
1-18	C5111500003	BEARING FLANGE	1	
1-19	0072906322	BEARING	1	
1-20	0080000110	SNAP RING	1	
1-21#	C5153300104	BEARING GASKET	1	
2	0012116065	HEX HEAD BOLT	10	
2A	0042516000	WASHER, LOCK	10	
3	C5130000003	STARTER ASSY.	1.....	INCLUDES ITEM W/\$
3-1\$	C5131200404	CLAMPER	4	
3-2\$	C5131200014	CLAMPER	4	
3-3\$	C5131200504	CLAMPER	2	
3-4\$	0016310090	HEX HEAD BOLT	4	
3-4A\$	0030010000	HEX NUT	4	
3-4B\$	0040010000	WASHER, LOCK	8	
3-4C\$	0041210000	WASHER, FLAT	4	
3-5\$	0017110020	HEX HEAD BOLT	8	
4	C5153000002	END BRACKET	1	
5	C4137000003	EXCITER FIELD ASSY	1	
6	0012110075	HEX HEAD BOLT	6	
6A	0042610000	WASHER, LOCK	6	
6B	0041210000	WASHER, FLAT	6	
7	0845044904	GROMMET	1	

GENERATOR ASSY. (CONT'D.)

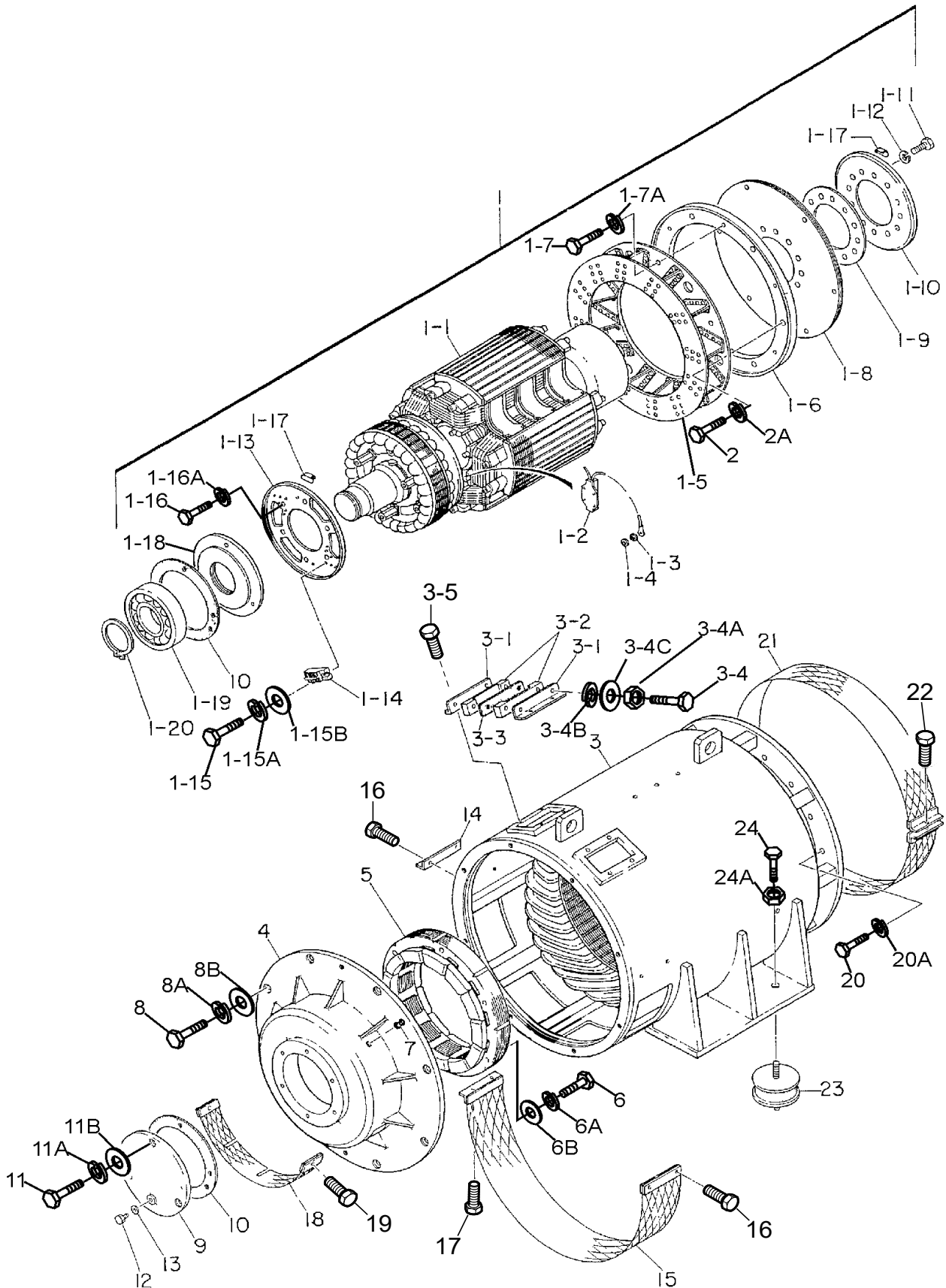

GENERATOR ASSY. (CONT'D.)

<u>NO.</u>	<u>PART NO.</u>	<u>PART NAME</u>	<u>QTY.</u>	<u>REMARKS</u>
8	0016316045	HEX HEAD BOLT	8	
8A	0040016000	WASHER, LOCK	8	
8B	0041216000	WASHER, FLAT	8	
9	C5153300003	BEARING COVER	1	
10	C5153300104	BEARING GASKET	1	
11	0016308095	HEX HEAD BOLT	3	
11A	0040008000	WASHER, LOCK	3	
11B	0041208000	WASHER, FLAT	3	
12	0010110016	HEX HEAD BOLT	1	
13	0803000104	PACKING	1	
14	8461335004	COVER BRACKET	1	
15	C5131300103	STATOR COVER	1	
16	0017106012	HEX HEAD BOLT	4	
17	0017106050	HEX HEAD BOLT	2	
18	8461333003	EXCITER COVER	1	
19	0017106012	HEX HEAD BOLT	2	
20	0012112040	HEX HEAD BOLT	16	
20A	0042512000	WASHER, LOCK	16	
21	C5131300003	FAN COVER	1	
22	0017106050	HEX HEAD BOLT	1	
23	0605000012	RUBBER SUSPENSION	4	
24	0030020000	HEX NUT	8	
24A	0040020000	WASHER, LOCK	8	

CONTROL PANEL ASSY.

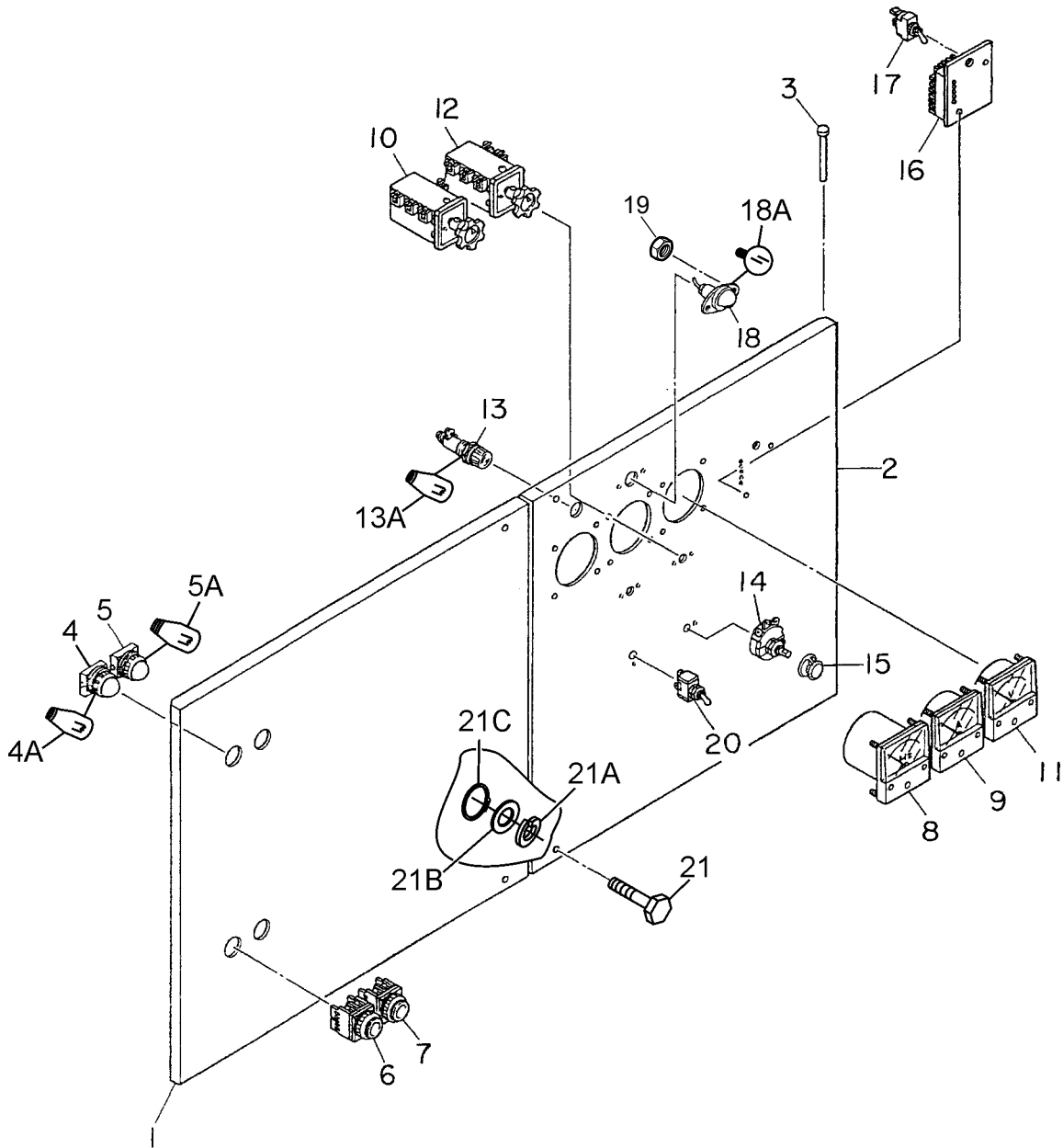

CONTROL PANEL ASSY.

<u>NO.</u>	<u>PART NO.</u>	<u>PART NAME</u>	<u>QTY.</u>	<u>REMARKS</u>
1	C5224002303	CONTROL PANEL	1	
2	C5224002103	CONTROL PANEL	1	
3	0605011211	PIN	4	
4	0601810476	CIRCUIT BREAKER OFF LAMP	1	
4A	0601810235	BULB	1	
5	0601810467	CIRCUIT BREAKER ON LAMP	1	
5A	0601810235	BULB	1	
6	0601830498	CIRCUIT BREAKER OFF SWITCH	1	
7	0601831224	CIRCUIT BREAKER ON SWITCH	1	
8	0601800480	FREQUENCY METER, 220V 45 ~ 65Hz	1	
9	0601800795	AC AMMETER, 0~1500A 0~3000A	1	
10	0601801040	AMMETER CHANGE OVER SWITCH	1	
11	0601800252	AC VOLTMETER, ~ 600V	1	
12	0601801041	VOLTMETER CHANGE OVER SWITCH	1	
13	0601810072	PILOT LAMP	1	
13A	0601810261	BULB	1	
14	0601840073	RHEOSTAT (VOLTAGE REGULATOR)	1	
15	0601840100	KNOB	1	
16	ECU99888N600/800	ENGINE CONTROLLER.....	1	REPLACES P/N 0602202545
17	0601830765	SWITCH	1	
18	0601810161	PANEL LIGHT	1	
18A	0601810214	BULB	1	
19	0207004000	HEX NUT	2	
20	0601830710	PANEL LIGHT SWITCH	1\	
21	C9221100004	HEX. HEAD BOLT	4	
21A	0040008000	WASHER, LOCK	4	
21B	0041208000	WASHER, FLAT	4	
21C	0080200007	SNAP RING	4	

CONTROL BOX ASSY.

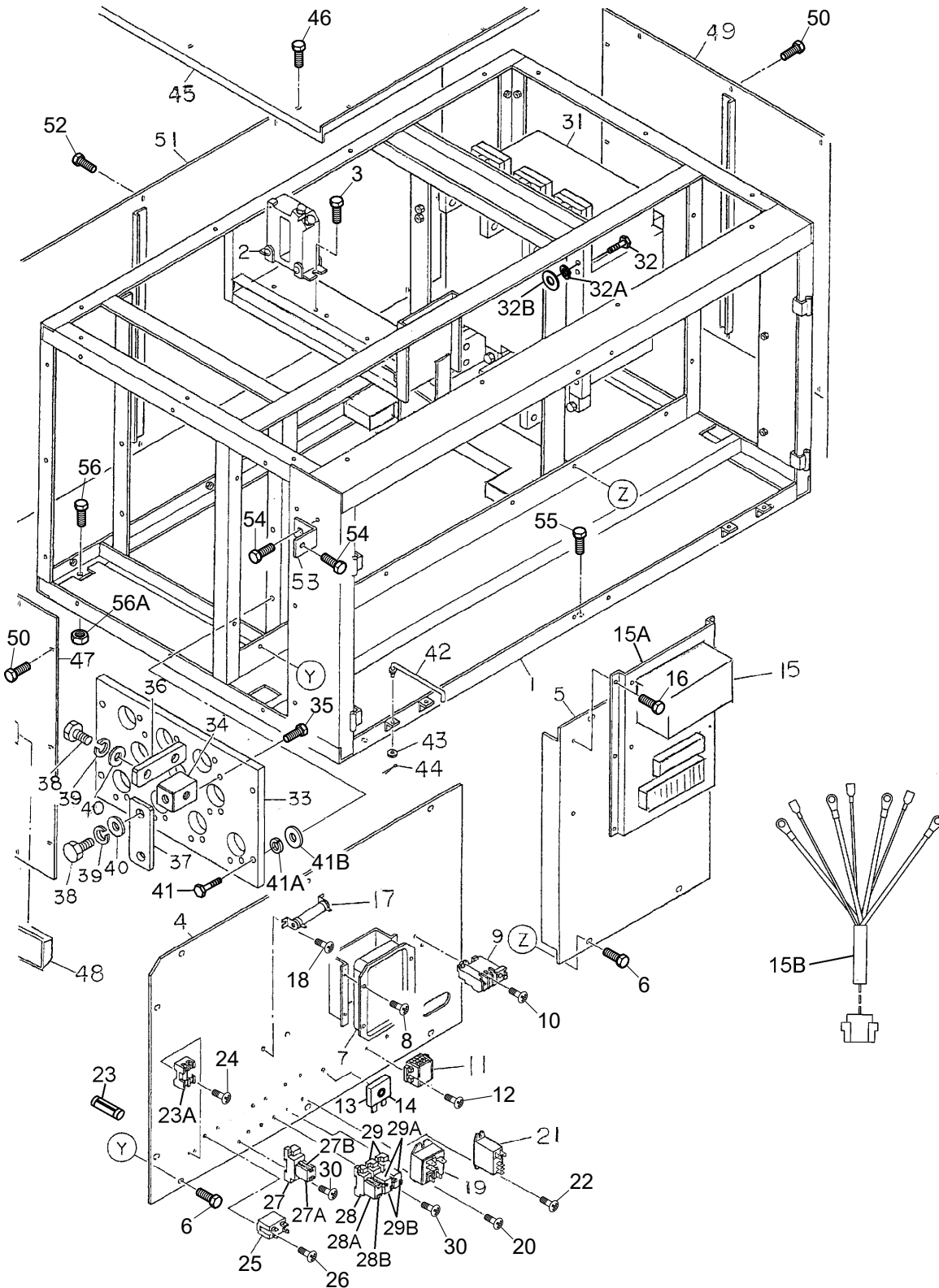

CONTROL BOX ASSY.

<u>NO.</u>	<u>PART NO.</u>	<u>PART NAME</u>	<u>QTY.</u>	<u>REMARKS</u>
1	C5214001602	CONTROL BOX	1	
2	0601806166	AMMETER CURRENT TRANSFORMER	3	
3	0017108020	HEX HEAD BOLT	6	
4	C5261503703	ELECTRIC PARTS SET PANEL	1	
5	C5261503503	ELECTRIC PARTS SET PANEL	1	
6	0017108020	HEX HEAD BOLT	14	
7	0601820625	AUTOMATIC VOLTAGE REGULATOR	1	
8	0027105016	MACHINE SCREW	4	
9	0601820892	OVER CURRENT RELAY	1	
10	0027104016	MACHINE SCREW	2	
11	0601815402	TERMINAL BOARD	1	
12	0027104020	MACHINE SCREW	2	
13	0601823240	RECTIFIER	1	
14	0027105020	MACHINE SCREW	1	
15	7818529500	CONTROLLER	1	REPLACES P/N 0602202615
15A	6240815300	PANEL.....	1	REPLACES P/N 0602129110
15B	6240815400	WIRE HARNESS	1	REPLACES P/N 0602202431
16	0017106015	HEX HEAD BOLT	6	
17	0601842468	RESISTOR, 5W 150 OHM	1	
18	0027103010	MACHINE SCREW	2	
19	0601828533	RELAY, DC24V	1	
20	0027104016	MACHINE SCREW	2	
21	0601826022	RELAY, DC24V	1	
22	0027103010	MACHINE SCREW	2	
23	0601802149	FUSE, 10A	1	
23A	0601802211	FUSE HOLDER	1	
24	0027504020	MACHINE SCREW	2	
25	0601823706	RELAY, DC24V	1	
26	0027104016	MACHINE SCREW	2	
27	LY2DC24V	RELAY	1	REPLACES P/N 0601823732
27A	PTF08A	SOCKET	1	REPLACES P/N 0601823109
27B	PYCA1	HOLDER.....	1	REPLACES P/N 0601824400
28	LY2DDC24V	RELAY	1	REPLACES P/N 0601827655
28A	PTF08A	SOCKET	1	REPLACES P/N 0601823109
28B	PYCA1	HOLDER.....	1	REPLACES P/N 0601824400
29	0601823759	RELAY	2	
29A	PYF14A	SOCKET	2	REPLACES P/N 0601823146
29B	PYCA1	HOLDER.....	2	REPLACES P/N 0601824000
30	0027104016	MACHINE SCREW	8	
31	M7080041000Q	CIRCUIT BREAKER, S8V 2500A	1	REPLACES P/N C5244300003
32	0010308050	HEX HEAD BOLT	8	
32A	0042508000	WASHER, LOCK	8	
32B	0041208000	WASHER, FLAT	8	
33	7521861303	VOLTAGE CHANGEOVER BOARD	1	

CONTROL BOX ASSY. (CONT'D.)

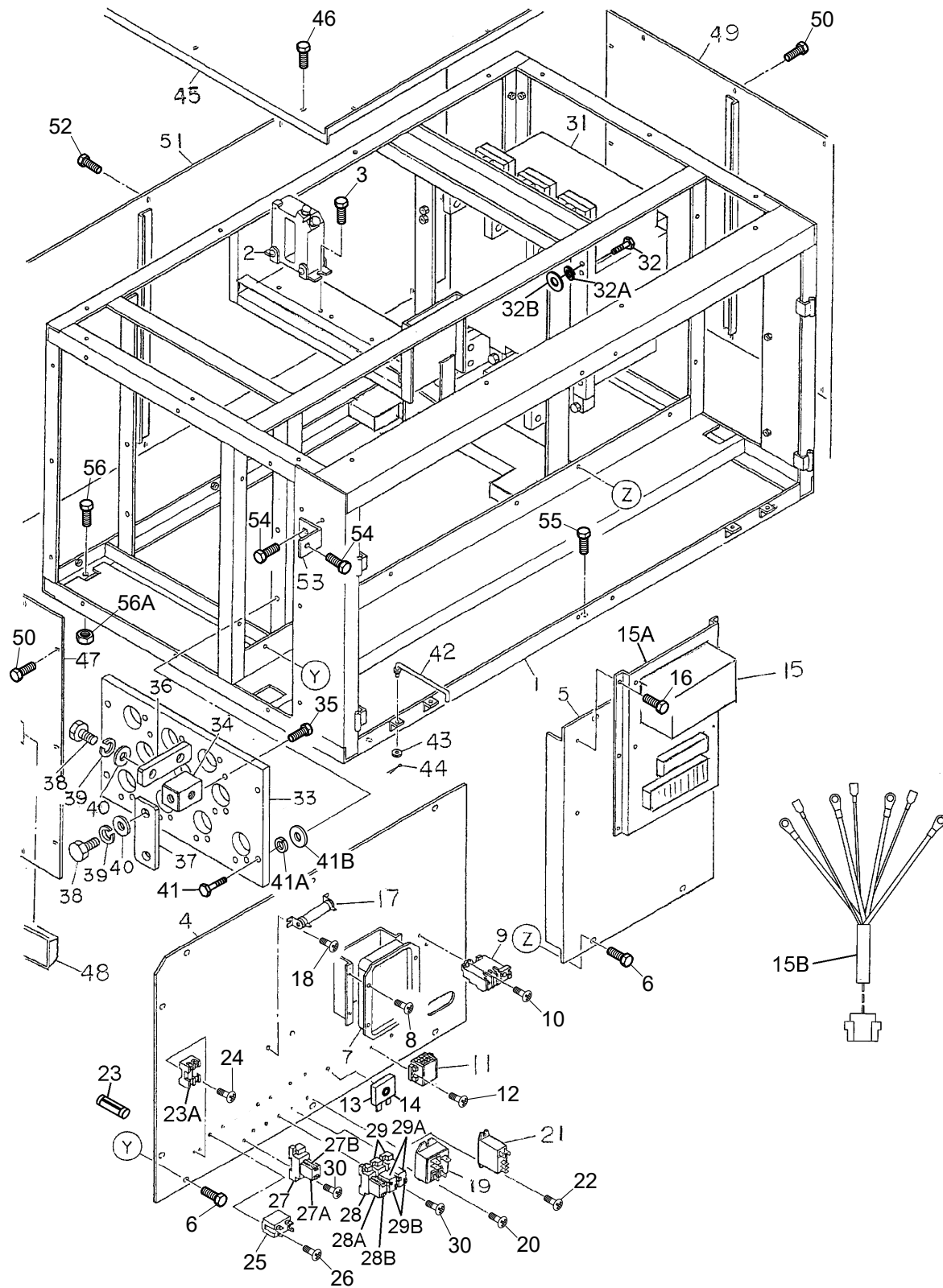

CONTROL BOX ASSY. (CONT'D.)

<u>NO.</u>	<u>PART NO.</u>	<u>PART NAME</u>	<u>QTY.</u>	<u>REMARKS</u>
34	C5277000004	CHANGE TERMINAL	10	
35	0017108035	HEX HEAD BOLT	20	
36	C5277200004	TERMINAL PLATE	10	
37	C5277300004	CHANGE PLATE	6	
38	0801832504	HEX HEAD BOLT	20	
39	0040020000	WASHER, LOCK	20	
40	0041420000	WASHER, FLAT	20	
41	0010110040	HEX HEAD BOLT	4	
41A	0040010000	WASHER, LOCK	4	
41B	0041210000	WASHER, FLAT	4	
42	3871824004	CONTROL PANEL STOPPER	2	
43	0041206000	WASHER, FLAT	2	
44	0605010502	SNAP PIN	2	
45	C5214500303	CONTROL BOX COVER	1	
46	0017106016	HEX HEAD BOLT	14	
47	C5214300304	CONTROL BOX SIDE PANEL	1	
48	0601850349	EMBEDDED PULLS	1	
49	C5214300404	CONTROL BOX SIDE PANEL	1	
50	0017106016	HEX HEAD BOLT	24	
51	C5214400203	CONTROL BOX PANEL	1	
52	0017106016	HEX HEAD BOLT	15	
53	7521811904	BRACKET	2	
54	0017110025	HEX HEAD BOLT	4	
55	0017108020	HEX HEAD BOLT	3	
56	0017110030	HEX HEAD BOLT	4	
56A	0207010000	HEX NUT	4	

ENGINE ASSY.

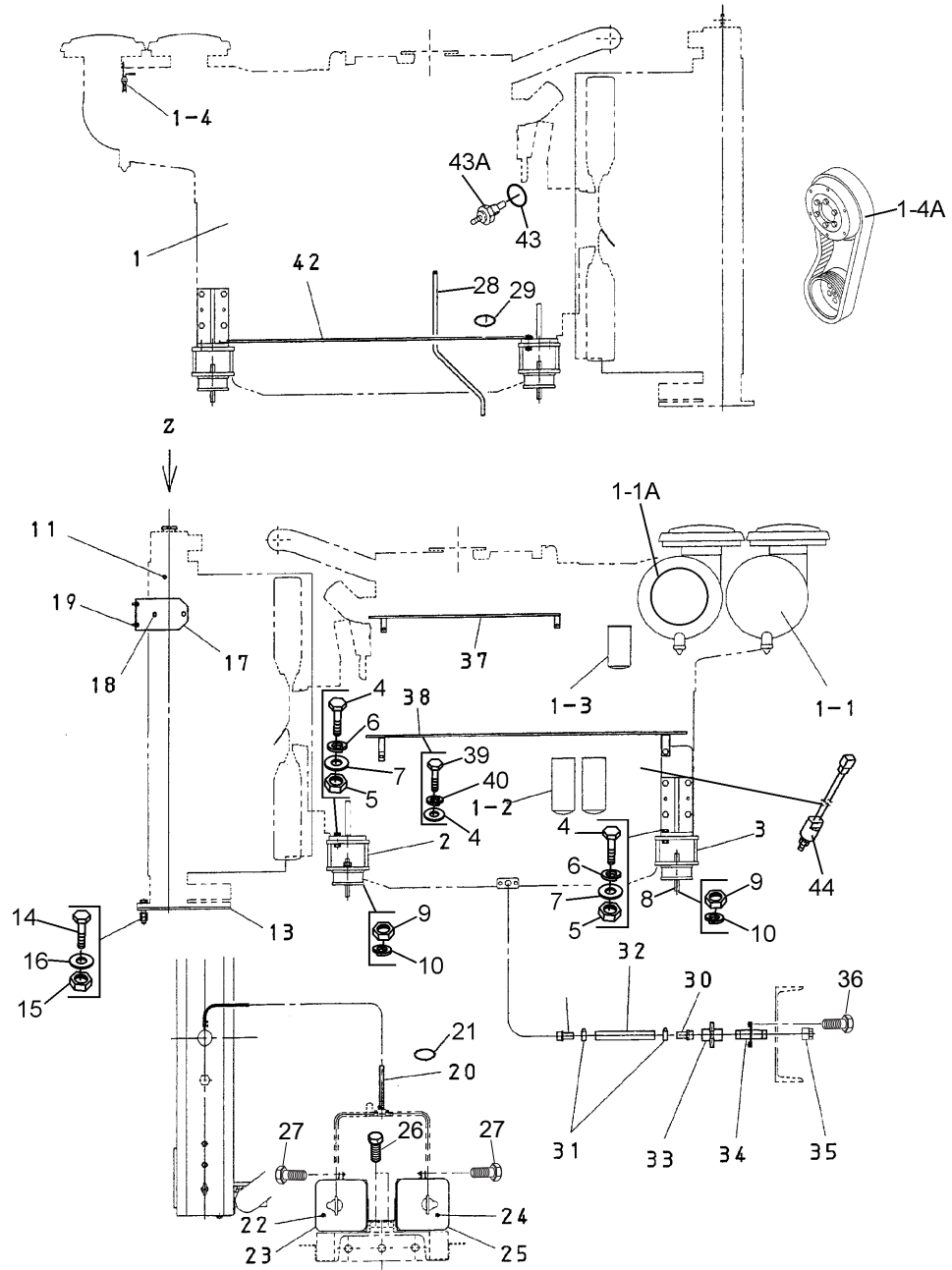

ENGINE ASSY.

<u>NO.</u>	<u>PART NO.</u>	<u>PART NAME</u>	<u>QTY.</u>	<u>REMARKS</u>
1	C5924200134	ENGINE, KOMATSU SAA170E3	1	
1-1	0602046653	AIR CLEANER ELEMENT OUTER	2	
1-1A	0602046653-1	AIR CLEANER ELEMENT, INNER	2	
1-2	6002111231	OIL FILTER CARTRIDGE	2	REPLACES P/N 0602041146
1-3	6004111171	CORROSION RESISTOR CARTRIDGE.....	1	REPLACES P/N 0602045144
1-4	6008711220	DUST SENSOR	1	REPLACES P/N 060204043
1-4A	6240613821	FAN BELT	1	REPLACES P/N 0602015227
2	C5304200504	ENGINE FOOT	2	
3	C5304200604	ENGINE FOOT	2	
4	0010118070	HEX HEAD BOLT	8	
5	0030018000	HEX NUT	8	
6	0040018000	WASHER, LOCK	8	
7	0041618000	WASHER, FLAT	8	
8	0605000012	RUBBER SUSPENSION	4	
9	0030020000	HEX NUT	8	
10	0040020000	WASHER, LOCK	8	
13	6995619380	CUSHION.....	2	REPLACES P/N 0605000498
14	0010118100	HEX HEAD BOLT	8	
15	0030018000	HEX NUT	16	
16	0041618000	WASHER, FLAT	16	
17	C5311100104	RADIATOR BRACKET	2	
18	0017112025	HEX HEAD BOLT	4	
19	0017110025	HEX HEAD BOLT	4	
20	0199603100	HOSE	1	
21	0605515170	HOSE CLIP	1	
22	6162637810	RESERVE TANK.....	1	REPLACES P/N 0602010207
23	C2317100503	RESERVE TANK BRACKET	1	
24	6212617210	RESERVE TANK.....	1	REPLACES P/N 0602010206
25	C5317100003	RESERVE TANK BRACKET	1	

ENGINE ASSY. (CONT'D.)

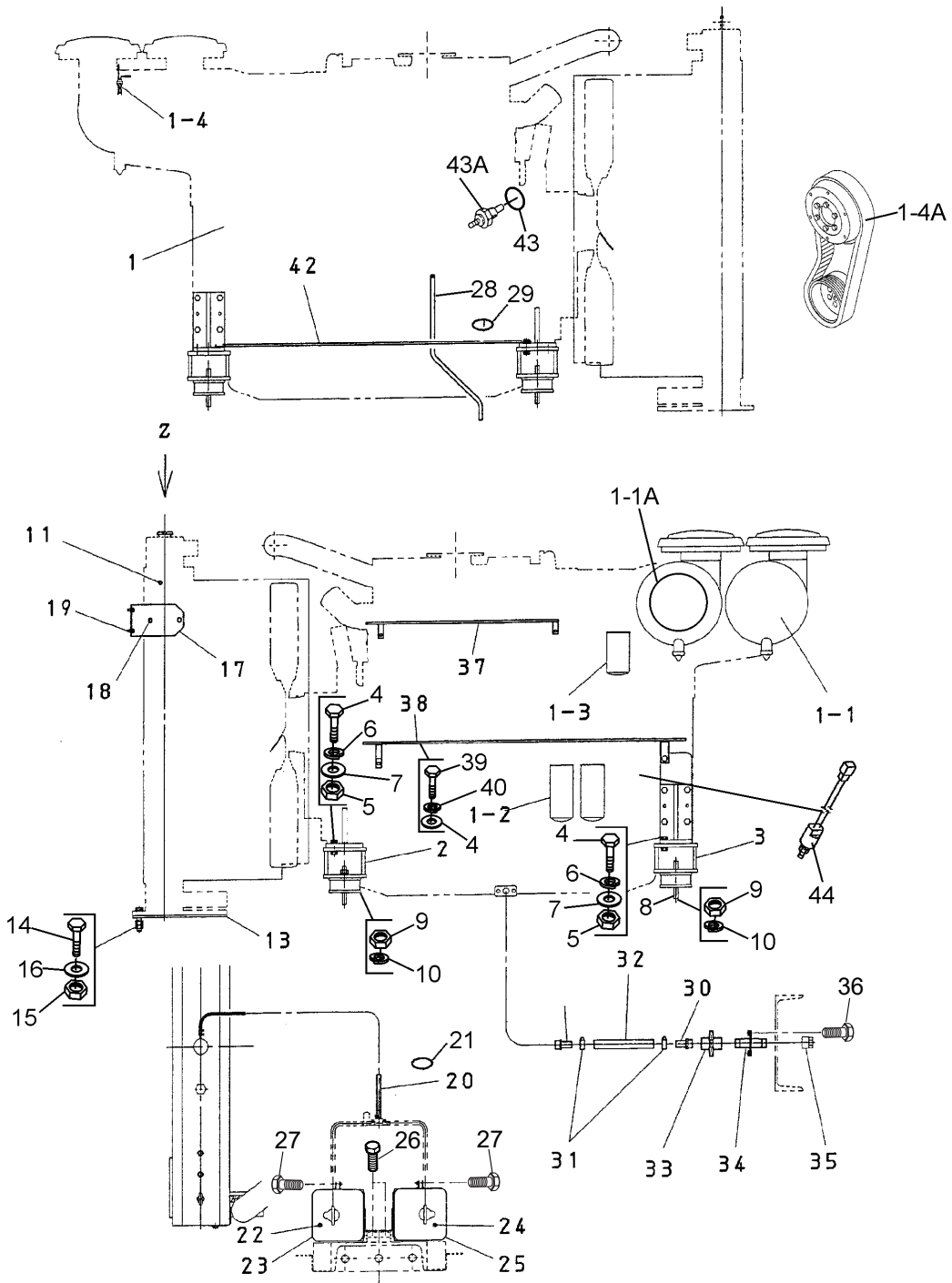

ENGINE ASSY. (CONT'D.)

<u>NO.</u>	<u>PART NO.</u>	<u>PART NAME</u>	<u>QTY.</u>	<u>REMARKS</u>
26	0017108020	HEX HEAD BOLT	4	
27	0017106030	HEX HEAD BOLT	2	
28	0194200840	HOSE	1	
29	0605515019	HOSE BAND	1	
30	0602022294	HOSE JOINT	2	
31	0605515074	HOSE BAND	2	
32	0265800560	HOSE	1	
33	0603325017	VALVE	1	
34	C0321200004	DRAIN JOINT	1	
35	C0321300004	CAP	1	
36	0019208025	HEX HEAD BOLT	2	
37	C5322600304	CLAMPER ROD	1	
38	C5358300904	CLAMPER ROD	1	
39	0010118030	HEX HEAD BOLT	1	
40	0040018000	WASHER, LOCK	1	
41	0041618000	WASHER, FLAT	1	
42	C5358300804	CLAMPER ROD	1	
43	6216849140	SENSOR ASSY., COOLANT TEMP.	1S/N 316346 AND ABOVE
43A	6735211930	O-RING	1	
44	6008158280	SWITCH, OIL PRESSURE.....	1S/N 316346 AND ABOVE

RADIATOR ASSY. (S/N 316346 AND ABOVE)

<u>NO.</u>	<u>PART NO.</u>	<u>PART NAME</u>	<u>QTY.</u>	<u>REMARKS</u>
1	6240619300	RADIATOR ASSY.	1	REPLACES P/N 0602012734
1A	1140348160	RADIATOR CAP	1	REPLACES P/N 0602011021
2	6995619380	CUSHION	2	
18	6240611950	HOSE, RADIATOR, UPPER, INNER	1	
19	0728101029	CLAMP	4	
20	6240612010	TUBE	1	
21	6240612020	BRACKET	2	
22	0101081020	BOLT	8	
23	0164331032	WASHER	8	
24	0728101029	CLAMP	4	
25	6240611960	HOSE	1	
26	6240612080	CONNECTOR	1	
27	6693629242	GASKET	1	
28	0101081025	BOLT	4	
29	0164331032	WASHER	4	
36	6162639651	HOSE, RADIATOR, LOWER	1	
37	0728101029	CLAMP	4	
38	0726120913	HOSE	1	
39	0728100197	CLAMP	2	
40	0803400536	BAND	2	
41	0704200617	PLUG	1	
42	6240112550	TUBE	1	
43	6162144810	HOSE	2	
44	0729900120	CLAMP	8	
45	6240112560	TUBE	1	
46	6162144810	HOSE	2	
47	0728900120	CLAMP	8	

ALTERNATOR ASSY. (S/N 311209 AND ABOVE)

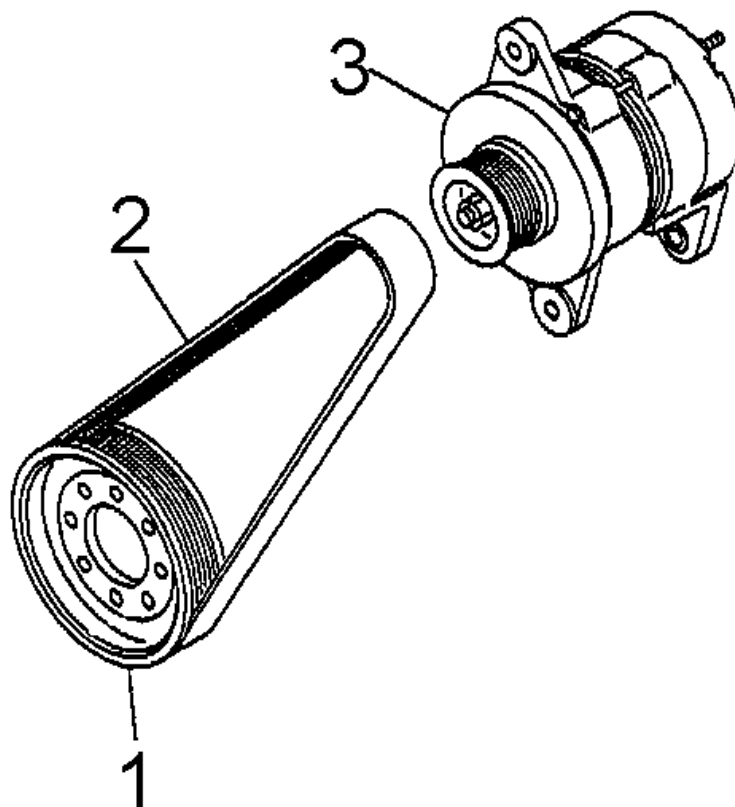

ALTERNATOR ASSY. (S/N 311209 AND ABOVE)

<u>NO.</u>	<u>PART NO.</u>	<u>PART NAME</u>	<u>QTY.</u>	<u>REMARKS</u>
1	6240816150	PULLEY, NON HARDENING	1	
2	6240816180	BELT, ALTERNATOR	1	
3	6008253161	ALTERNATOR ASSY.	1	

THERMOSTAT ASSY. (S/N 316346 AND ABOVE)

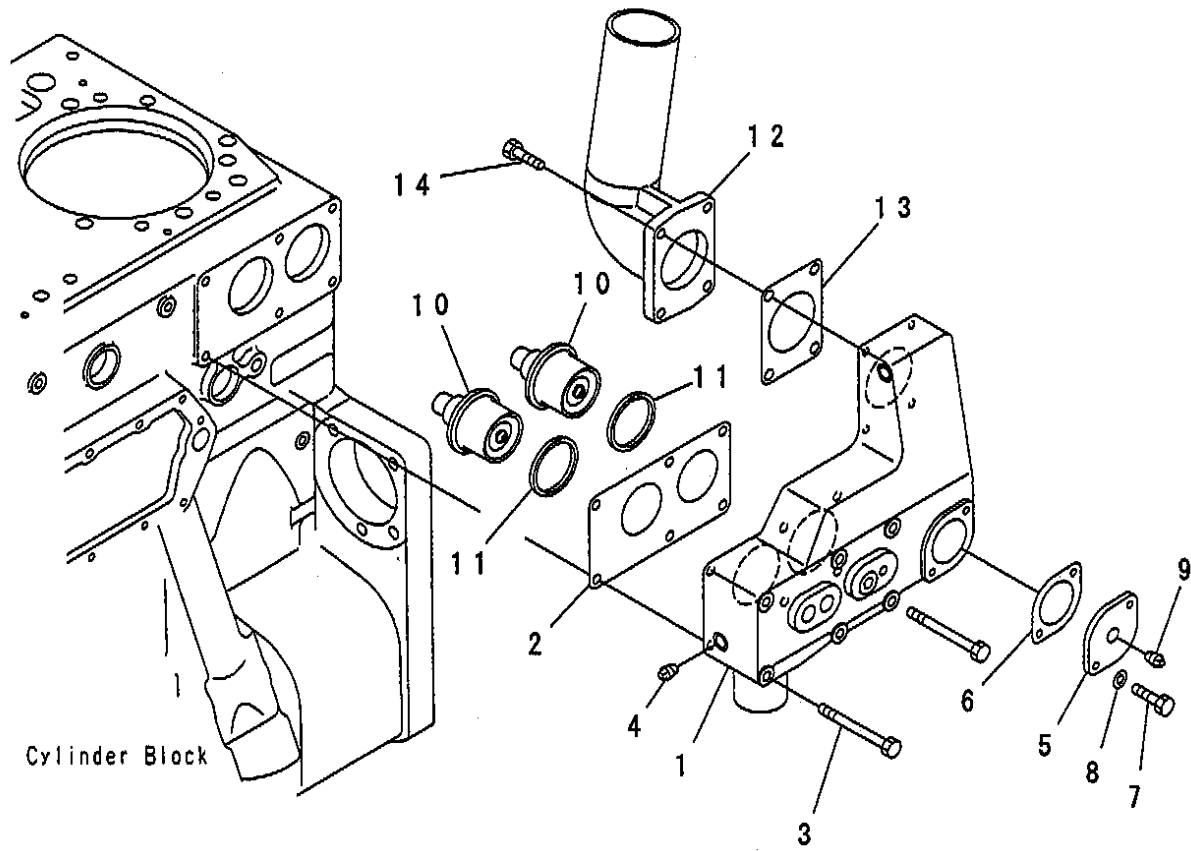

THERMOSTAT ASSY. (S/N 316346 AND ABOVE)

<u>NO.</u>	<u>PART NO.</u>	<u>PART NAME</u>	<u>QTY.</u>	<u>REMARKS</u>
1	6240116410	HOUSING, THERMOSTAT	1	
2	6240116470	GASKET	1	
3	0101081095	BOLT	5	
4	0704230108	PLUG	2	
5	6240116480	PLATE	1	
6	6222116820	GASKET	1	
7	0101081035	BOLT	2	
8	0164331032	WASHER	2	
9	0704200415	PLUG	1	
10	6004216630	THERMOSTAT	2	
11	6162136440	SEAL, THERMOSTAT	?	
12	6240611761	TUBE	1	
13	6162136481	GASKET	1	
14	0101081030	BOLT	4	

WATER PUMP ASSY.

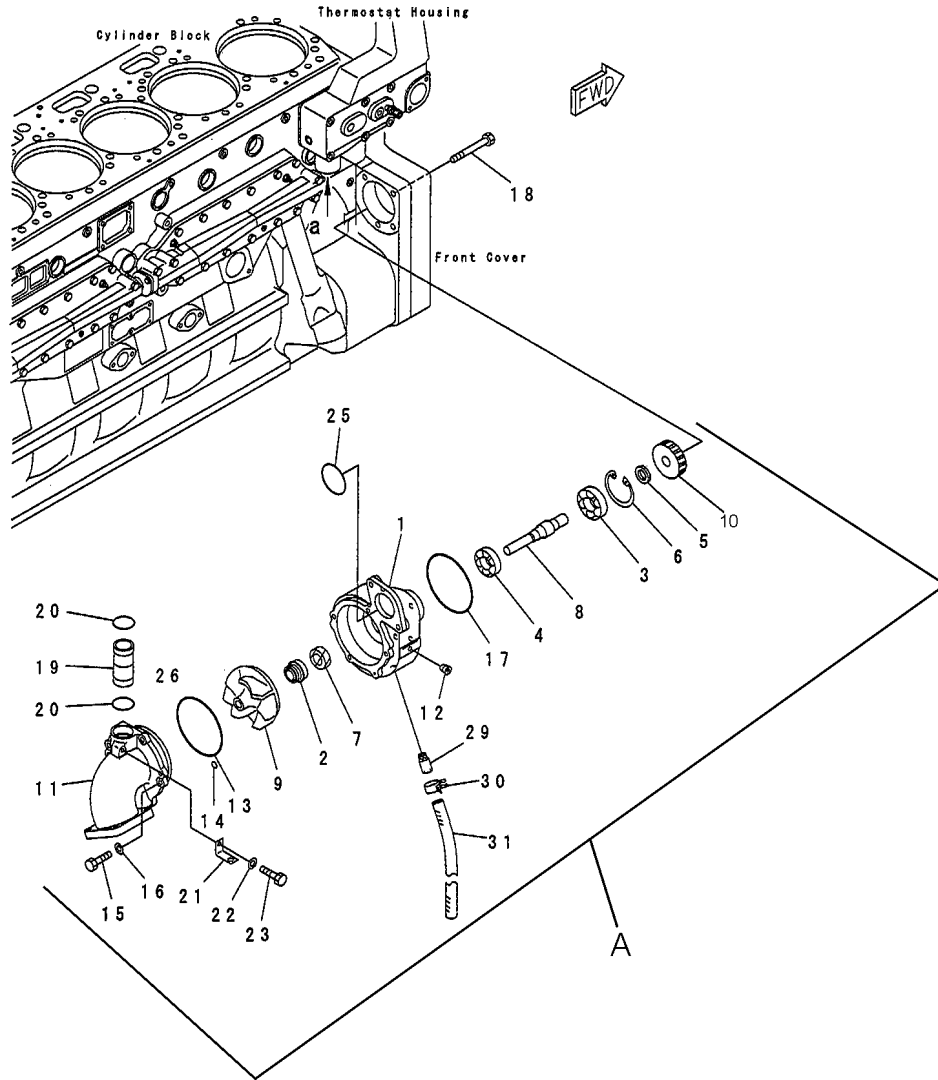

WATER PUMP ASSY.

<u>NO.</u>	<u>PART NO.</u>	<u>PART NAME</u>	<u>QTY.</u>	<u>REMARKS</u>
A	6240611302	WATER PUMP ASSY.....	1.....	S/N 315602 AND ABOVE INCLUDES ITEMS W/\$
1\$		BODY	1.....	S/N 315602 AND ABOVE
2\$	6162631515	SEAL, WATER.....	1.....	S/N 311819 AND ABOVE
3\$	0634006305	BEARING, BALL.....	1.....	S/N 310007 AND ABOVE
4\$	0603006205	BEARING, BALL.....	1.....	S/N 310007 AND ABOVE
5\$	6240611470	SPACER.....	1.....	S/N 310007 AND ABOVE
6\$	6240611440	RING	1.....	S/N 310007 AND ABOVE
7\$	07012D0022	SEAL, OIL.....	1.....	S/N 310007 AND ABOVE
8\$	6240611321	SHAFT.....	1.....	S/N 311819 AND ABOVE
9\$	6240611210	IMPELLER.....	1.....	S/N 310007 AND ABOVE
10\$	6240611410	GEAR	1.....	S/N 310007 AND ABOVE
11\$	6240611150	COVER.....	1.....	S/N 310007 AND ABOVE
12\$	0704370211	PLUG.....	1.....	S/N 310007 AND ABOVE
13\$	07000G2140	O-RING	1.....	S/N 310007 AND ABOVE
14\$	07000G2012	O-RING	1.....	S/N 310007 AND ABOVE
15\$	0101081030	BOLT	4.....	S/N 310007 AND ABOVE
16\$	0164331032	WASHER.....	4.....	S/N 310007 AND ABOVE
17	0700072095	O-RING	1.....	S/N 310007 AND ABOVE
18	0101181215	BOLT	4.....	S/N 310007 AND ABOVE
19	6240611560	TUBE.....	1.....	S/N 310007 AND ABOVE
20	07000A3039	O-RING	2.....	S/N 310007 AND ABOVE
21	6150215720	BRACKET	1.....	S/N 310007 AND ABOVE
22	0101080812	BOLT	1.....	S/N 310007 AND ABOVE
23	0164020816	WASHER.....	1.....	S/N 310007 AND ABOVE
25	07000G2075	O-RING	1.....	S/N 310007 AND ABOVE
29	6162631270	NIPPLE.....	1.....	S/N 310007 AND ABOVE
30	0728500180	CLIP	1.....	S/N 310007 AND ABOVE
31	0728701410	HOSE	1.....	S/N 310007 AND ABOVE

STARTER ASSY. (S/N 316346 AND ABOVE)

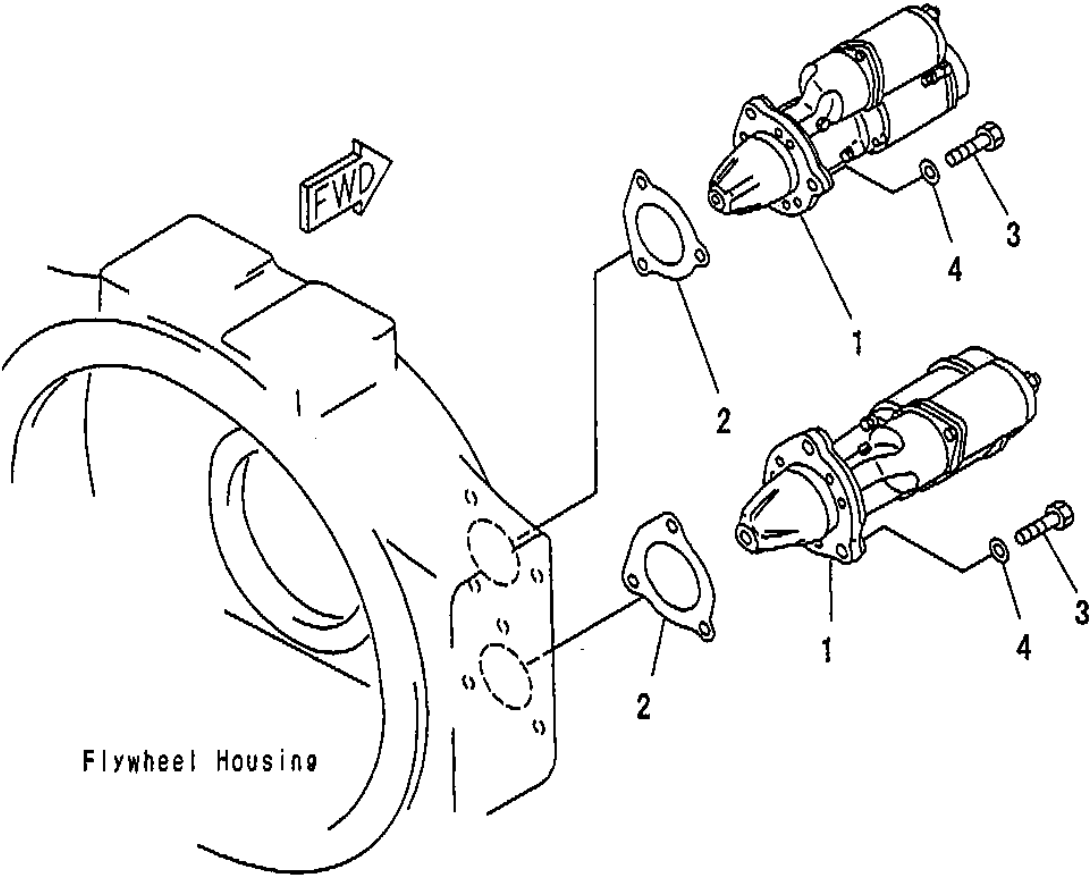

STARTER ASSY. (S/N 316346 AND ABOVE)

<u>NO.</u>	<u>PART NO.</u>	<u>PART NAME</u>	<u>QTY.</u>	<u>REMARKS</u>
1	6008133512	STARTING MOTOR ASSY. (7.5 KW)	2	
2	6221816810	GASKET	2	
3	0101061645	BOLT	6	
4	0164331645	WASHER	6	

ENGINE OPERATING PANEL ASSY.

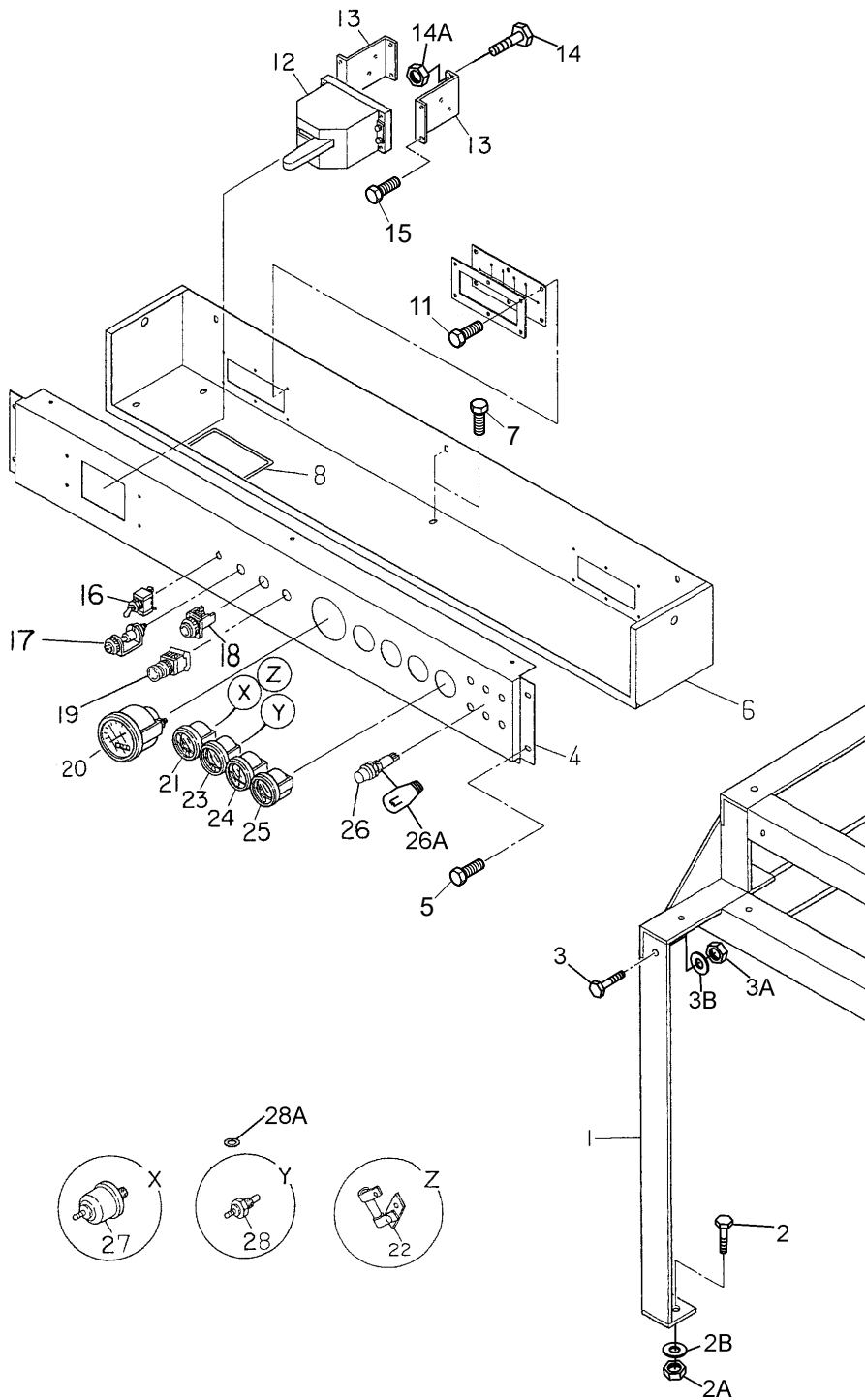

ENGINE OPERATING PANEL ASSY.

<u>NO.</u>	<u>PART NO.</u>	<u>PART NAME</u>	<u>QTY.</u>	<u>REMARKS</u>
1	C5484001202	SUPPORT LEG	1	
2	0017112045	HEX HEAD BOLT	4	
2A	0030012000	HEX NUT	4	
2B	0041212000	WASHER, FLAT	4	
3	0019210025	HEX HEAD BOLT	2	
3A	0205010000	HEX NUT	2	
3B	0042412000	WASHER, FLAT	2	
4	C5352101303	OPERATING PANEL	1	
5	0019208020	HEX HEAD BOLT	4	
6	C5352100213	OPERATING PANEL COVER	1	
7	0019208020	HEX HEAD BOLT	8	
8	0226900460	RUBBER SEAL	1	
9	8085182004	RUBBER COVER	1	
10	8085183004	RUBBER COVER SET FRAME	1	
11	0019206020	HEX HEAD BOLT	6	
12	0602101016	BATTERY SWITCH	1	
13	7522258304	BATTERY SWITCH BRACKET	2	
14	0017106030	HEX HEAD BOLT	4	
14A	0207006000	HEX NUT	4	
15	0019206015	HEX HEAD BOLT	4	
16	0601830710	ENGINE SPEED SWITCH	1	
17	K6008153730	PREHEAT INDICATOR	1	REPLACES P/N 0602102055
18	0601830448	PREHEAT BUTTON	1	
19	0601831927	EMERGENCY STOP BUTTON	1	
20	0602120095	TACHOMETER	1	
21	0602122093	OIL PRESSURE GAUGE	1	
22	0601842450	VOLTAGE DIVIDER	1	
23	0602123092	WATER TEMPERATURE GAUGE	1	
24	0602121080	CHARGING AMMETER	1	
25	0602125091	FUEL GAUGE	1	
26	0602103090	ALARM LAMP	6	
26A	0601810244	BULB, DC28V	6	
27	0602122272	OIL PRESSURE UNIT FOR GAUGE	1	
28	0602123267	WATER TEMP. UNIT FOR GAUGE	1	
28A	0602021109	PACKING	1	

OUTPUT TERMINAL ASSY.

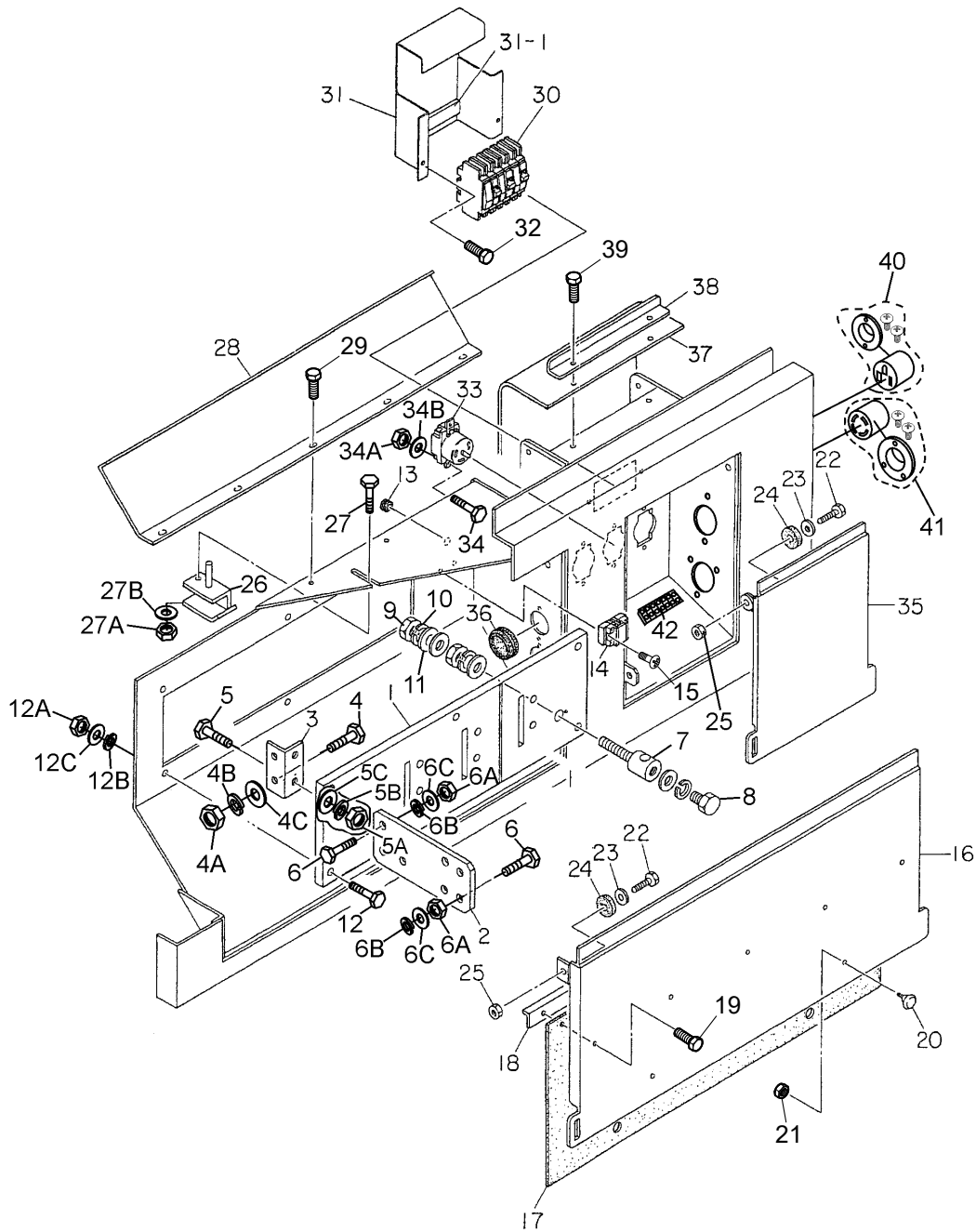

OUTPUT TERMINAL ASSY.

<u>NO.</u>	<u>PART NO.</u>	<u>PART NAME</u>	<u>QTY.</u>	<u>REMARKS</u>
1	C5231700003	OUTPUT TERMINAL SET BOARD	1	
2	7521860504	OUTPUT TERMINAL	4	
3	7521850504	OUTPUT TERMINAL BRACKET	4	
4	0010112040	HEX HEAD BOLT	8	
4A	0030012000	HEX NUT	8	
4B	0040012000	WASHER, LOCK	8	
4C	0041212000	WASHER, FLAT	16	
5	0010112060	HEX HEAD BOLT	8	
5A	0030012000	HEX NUT	8	
5B	0040012000	WASHER, LOCK	8	
5C	0041212000	WASHER, FLAT	16	
6	00101112040	HEX HEAD BOLT	24	
6A	0030012000	HEX NUT	24	
6B	0040012000	WASHER, LOCK	24	
6C	0041212000	WASHER, FLAT	48	
7	C5234000004	TERMINAL	1	
8	0801830904	HEX HEAD BOLT	1	
9	0039320000	HEX NUT	2	
10	0040020000	WASHER, LOCK	3	
11	0041420000	WASHER, FLAT	4	
12	0019112050	HEX HEAD BOLT	6	
12A	0042312000	WASHER, LOCK	6	
12B	0042412000	WASHER, FLAT	6	
13	0601850275	GROMMET	1	
14	0601815324	TERMINAL BOARD	1	
15	0027104020	MACHINE SCREW	2	
16	C4237101304	OUTPUT TERMINAL COVER	1	
17	7971867114	RUBBER SHEET	1	
18	7521865804	RUBBER SHEET SET PLATE	1	
19	0019206020	HEX HEAD BOLT	5	
20	0605010660	KNOB	2	
21	0207006000	HEX NUT	2	
22	0019212040	HEX HEAD BOLT	4	
23	0041212000	WASHER, FLAT	4	
24	0805009804	RUBBER STAY	4	
25	0030012000	HEX NUT	4	
26	7521865603	STOPPER	1	
27	0010108030	HEX HEAD BOLT	1	
27A	0030008000	HEX NUT	1	
27B	0041208000	WASHER, FLAT	2	
28	C4237100504	COVER	1	
29	0017108020	HEX HEAD BOLT	5	
30	0601808804	CIRCUIT BREAKER, 50A	3	

OUTPUT TERMINAL ASSY (CONT'D.)

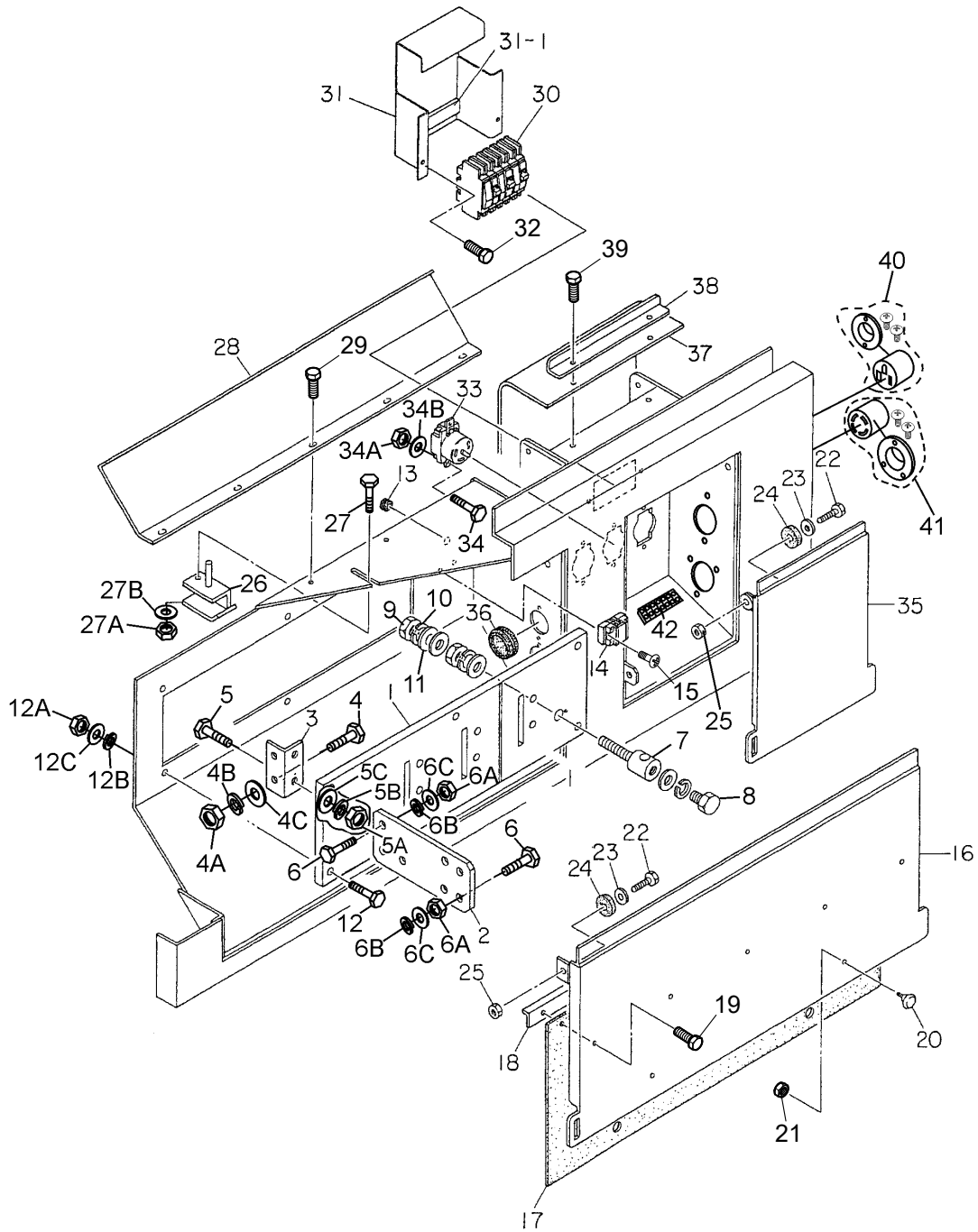

OUTPUT TERMINAL ASSY. (CONT'D.)

<u>NO.</u>	<u>PART NO.</u>	<u>PART NAME</u>	<u>QTY.</u>	<u>REMARKS</u>
31	C5261600204	CIRCUIT BREAKER BRACKET	1	
311	0221200110	RUBBER CUSHION	1	
32	0017106030	HEX HEAD BOLT	2	
33	0601811034	RECEPTACLE	3	
34	0027104015	MACHINE SCREW	6	
34A	0030004000	HEX NUT	6	
34B	0041204000	WASHER, FLAT	6	
35	C4237101203	COVER	1	
36	0601851780	GROMMET	2	
37	C4237102804	COVER	1	
38	C4237400804	BRACKET	1	
39	0017106016	HEX HEAD BOLT	2	

BATTERY ASSY.

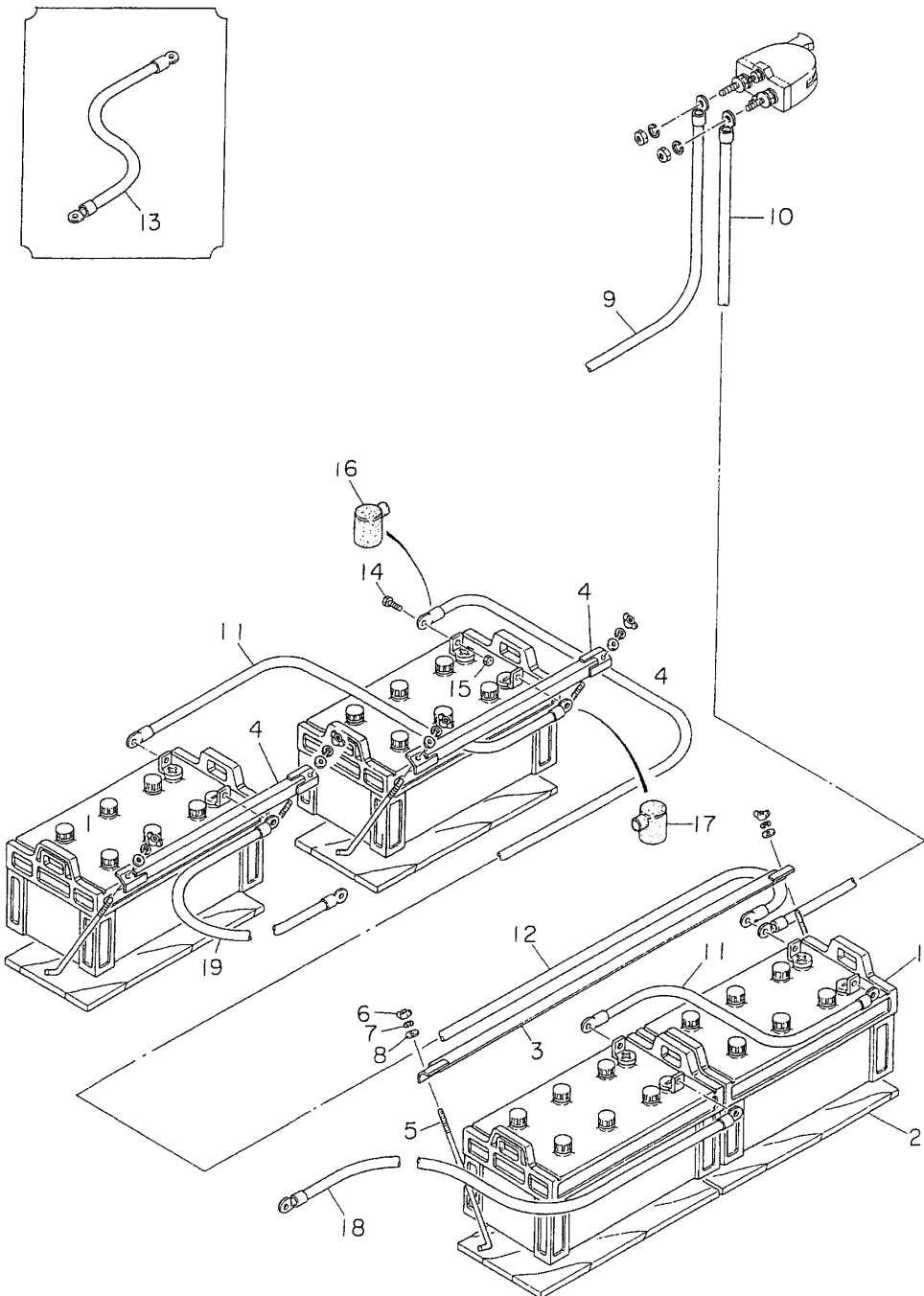

BATTERY ASSY.

<u>NO.</u>	<u>PART NO.</u>	<u>PART NAME</u>	<u>QTY.</u>	<u>REMARKS</u>
1	0165719052	BATTERY	4	
2	C9109100704	BATTERY SHEET	4	
3	0805006404	BATTERY BAND	1	
4	0805007804	BATTERY BAND	2	
5	0805006504	BATTERY BOLT	6	
6	0037808000	WING NUT	6	
7	0040008000	WASHER, LOCK	6	
8	0041608000	WASHER, FLAT	6	
9	C5347800504	BATTERY CABLE	1	
10	C5347800404	BATTERY CABLE	1	
11	7522280904	BATTERY CABLE	2	
12	C5347601404	BATTERY CABLE	1	
13	C5347400104	EARTH CABLE	1	
14	0347010030	HEX HEAD BOLT	8	
15	0208110000	HEX NUT	8	
16	0845040114	TERMINAL CAP (+)	4	
17	0845041004	TERMINAL CAP (-)	4	
18	C5347601304	BATTERY CABLE	1	
19	C5347601204	BATTERY CABLE	1	

MUFFLER ASSY.

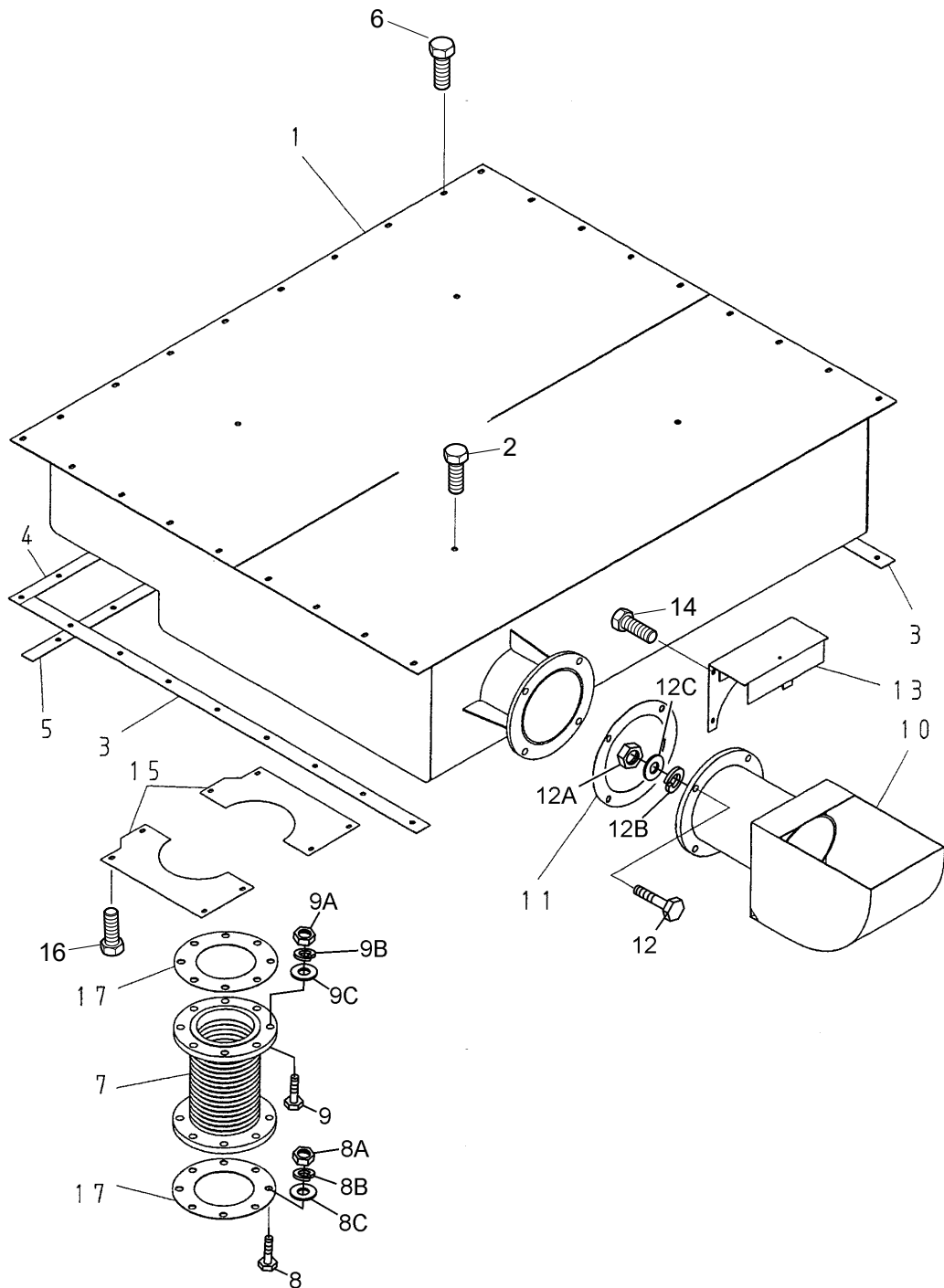

MUFFLER ASSY.

<u>NO.</u>	<u>PART NO.</u>	<u>PART NAME</u>	<u>QTY.</u>	<u>REMARKS</u>
1	C5331100302	MUFFLER	1	
2	0019212030	HEX HEAD BOLT	4	
3	C5334200704	PACKING	2	
4	C5335200204	PACKING	1	
5	C5335200304	PACKING	1	
6	0019210035	HEX HEAD BOLT	26	
7	C5334000403	EXHAUST PIPE	2	
8	0010116070	HEX HEAD BOLT	8	
8A	0030016000	HEX NUT	8	
8B	0040016000	WASHER, LOCK	8	
8C	0041616000	WASHER, FLAT	16	
9	0010116050	HEX HEAD BOLT	8	
9A	0040016000	WASHER, LOCK	8	
9B	0041616000	WASHER, FLAT	8	
10	C5334101503	OUTLET PIPE	1	
11	C5335200004	GASKET	1	
12	0010116070	HEX HEAD BOLT	4	
12A	0030016000	HEX NUT	4	
12B	0040016000	WASHER, LOCK	4	
12C	0041616000	WASHER, FLAT	8	
13	C5331300304	COVER	1	
14	0019208020	HEX HEAD BOLT	4	
15	C5331400104	COVER	2	
16	0019208020	HEX HEAD BOLT	8	
17	C4334200504	GASKET	2	

FUEL TANK ASSY.

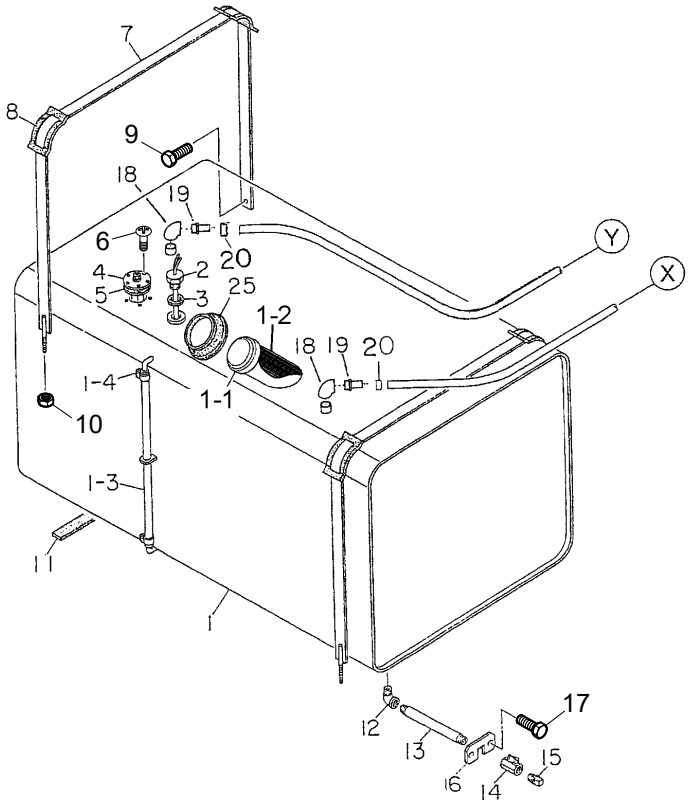
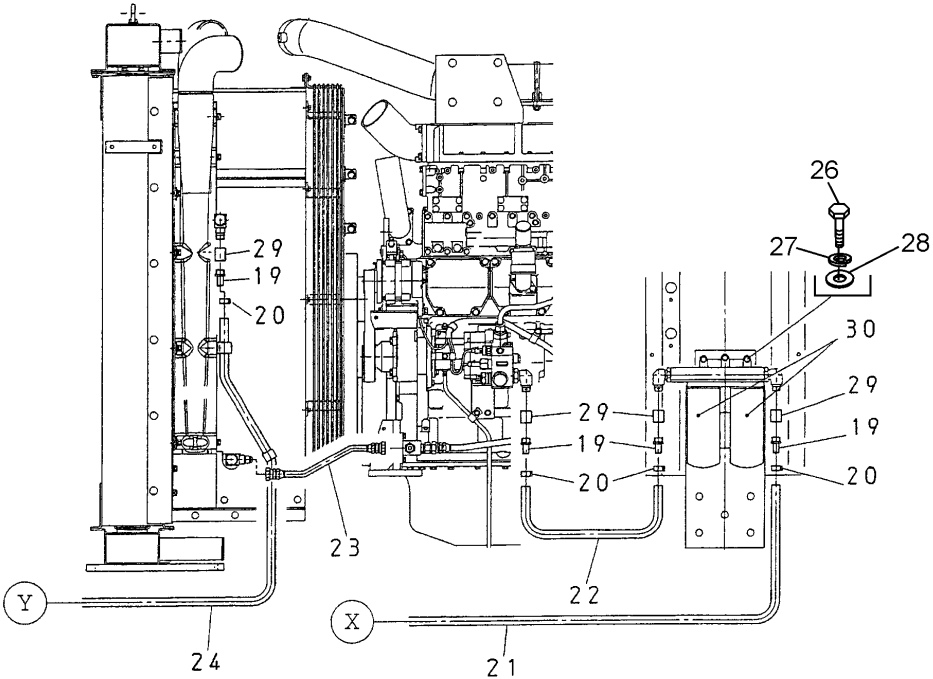

FUEL TANK ASSY.

<u>NO.</u>	<u>PART NO.</u>	<u>PART NAME</u>	<u>QTY.</u>	<u>REMARKS</u>
1	C5364001003	FUEL TANK	1	
11	0845500104	FUEL TANK CAP	1	
12	0810105400	FUEL FILTER	1	
13	0264100525	FUEL GAUGE HOSE	1	
14	0605515079	HOSE BAND	2	
2	0605503023	FUEL SENSOR	1	
3	0802120604	PACKING	1	
4	0605501093	FUEL UNIT	1	
5	0022905015	PACKING	1	
6	0605516090	MACHINE SCREW	5	
7	C6364200104	TANK BAND	2	
8	0805003414	TANK BAND PAD	4	
9	0017108020	HEX HEAD BOLT	2	
10	0207308000	HEX NUT	2	
11	0222100600	TANK SHEET	6	
12	0130206000	STREET ELBOW	1	
13	0134306370	DRAIN PIPE	1	
14	0603325026	VALVE	1	
15	0132006000	PLUG	1	
16	C1367700304	LOCK PLATE	1	
17	0019208020	HEX HEAD BOLT	2	
18	0130008000	ELBOW	2	
19	0602022225	HOSE JOINT	6	
20	0605515074	HOSE BAND	6	
21	0265803400	SUCTION HOSE	1	
22	0265801900	SUCTION HOSE	1	
23	6240715690	RETURN HOSE.....	1.....	REPLACES P/N 0605514120
24	0265803900	RETURN HOSE	1	
25	0845039604	RUBBER SEAL	1	
26	0010110100	HEX HEAD BOLT	3	
27	0040010000	WASHER, LOCK	3	
28	0041610000	WASHER, FLAT	3	
29	0131108000	SOCKET	4	
30	6003193320	FUEL FILTER CARTRIDGE.....	2.....	REPLACES P/N 0602042583

ENCLOSURE ASSY. #1

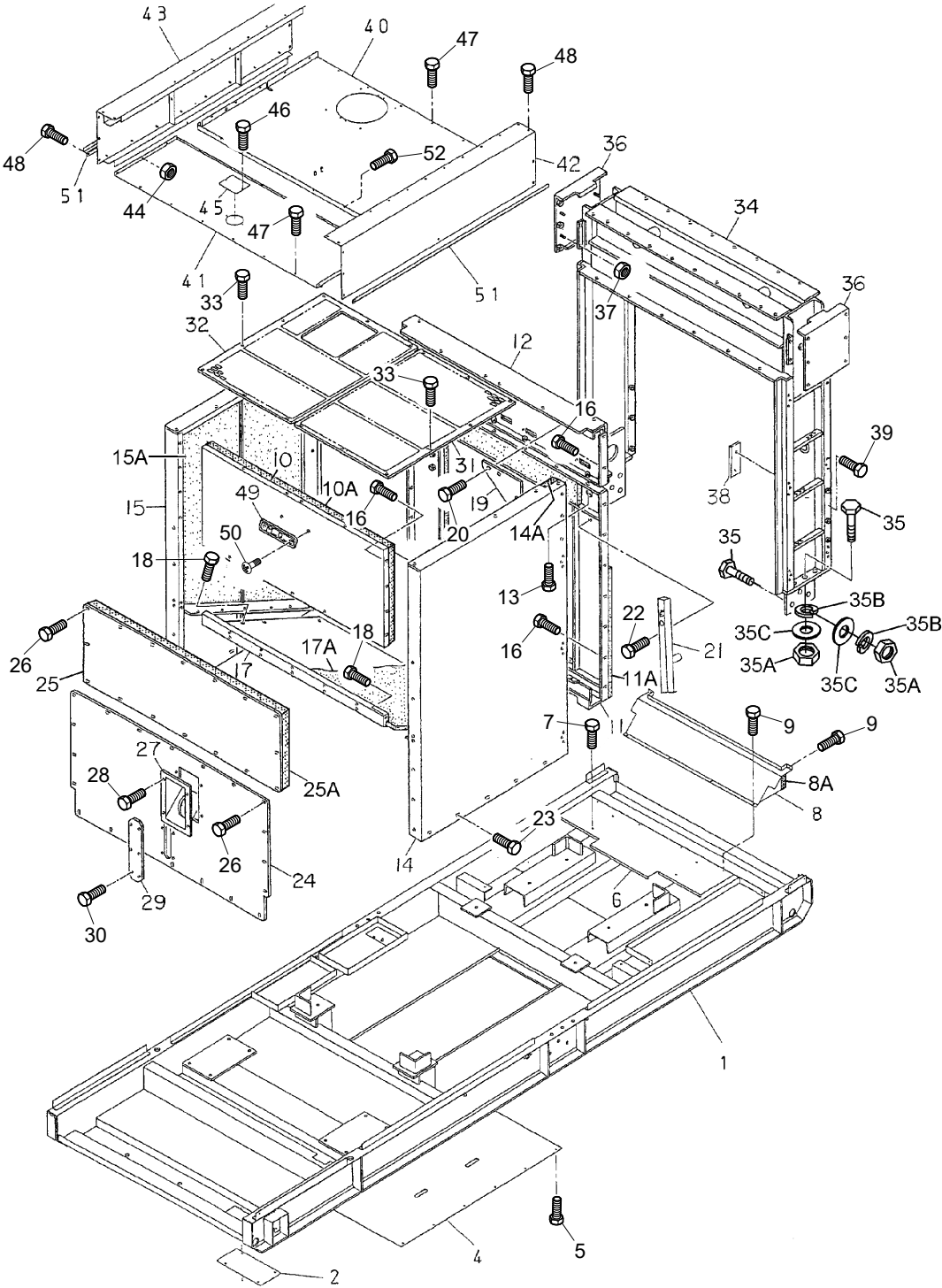

ENCLOSURE ASSY. #1

<u>NO.</u>	<u>PART NO.</u>	<u>PART NAME</u>	<u>QTY.</u>	<u>REMARKS</u>
1	C5414001502	BASE	1	
2	C5414100204	FLOOR PANEL	1	
3	0019208020	HEX HEAD BOLT	4	
4	C5414100104	FLOOR PANEL	1	
5	0019208020	HEX HEAD BOLT	12	
6	C5414600403	AIR GUIDE PANEL	1	
7	0019208020	HEX HEAD BOLT	4	
8	C5414600503	BASE DUCT	1	
8A	C5494000204	LINING	1	
9	0019208020	HEX HEAD BOLT	6	
10	C5424002803	FRONT FRAME	1	
10A	C5494100603	LINING	1	
11	C5424003003	FRONT FRAME	1	
11A	C5494100603	LINING	1	
12	C5424002903	FRONT FRAME	1	
13	0019208020	HEX HEAD BOLT	6	
14	C5424002402	FRONT FRAME	1	
14A	C5494100603	LINING	1	
15	C5424002502	FRONT FRAME	1	
15A	C5494100603	LINING	1	
16	0019208020	HEX HEAD BOLT	28	
17	C5424002603	AIR GUIDE PANEL	1	
17A	C5494100603	LINING	1	
18	0019208020	HEX HEAD BOLT	18	
19	C5424002704	GUSSET	2	
20	0019210025	HEX HEAD BOLT	8	
21	C5327100504	BREATHING PIPE	1	
22	0016908020	HEX HEAD BOLT	1	
23	0019210025	HEX HED BOLT	8	
24	C5424201803	FRONT FRAME COVER	1	
25	C5424202103	FRONT FRAME COVER	1	
25A	C5494100704	LINING	1	

ENCLOSURE ASSY. #1 (CONT'D.)

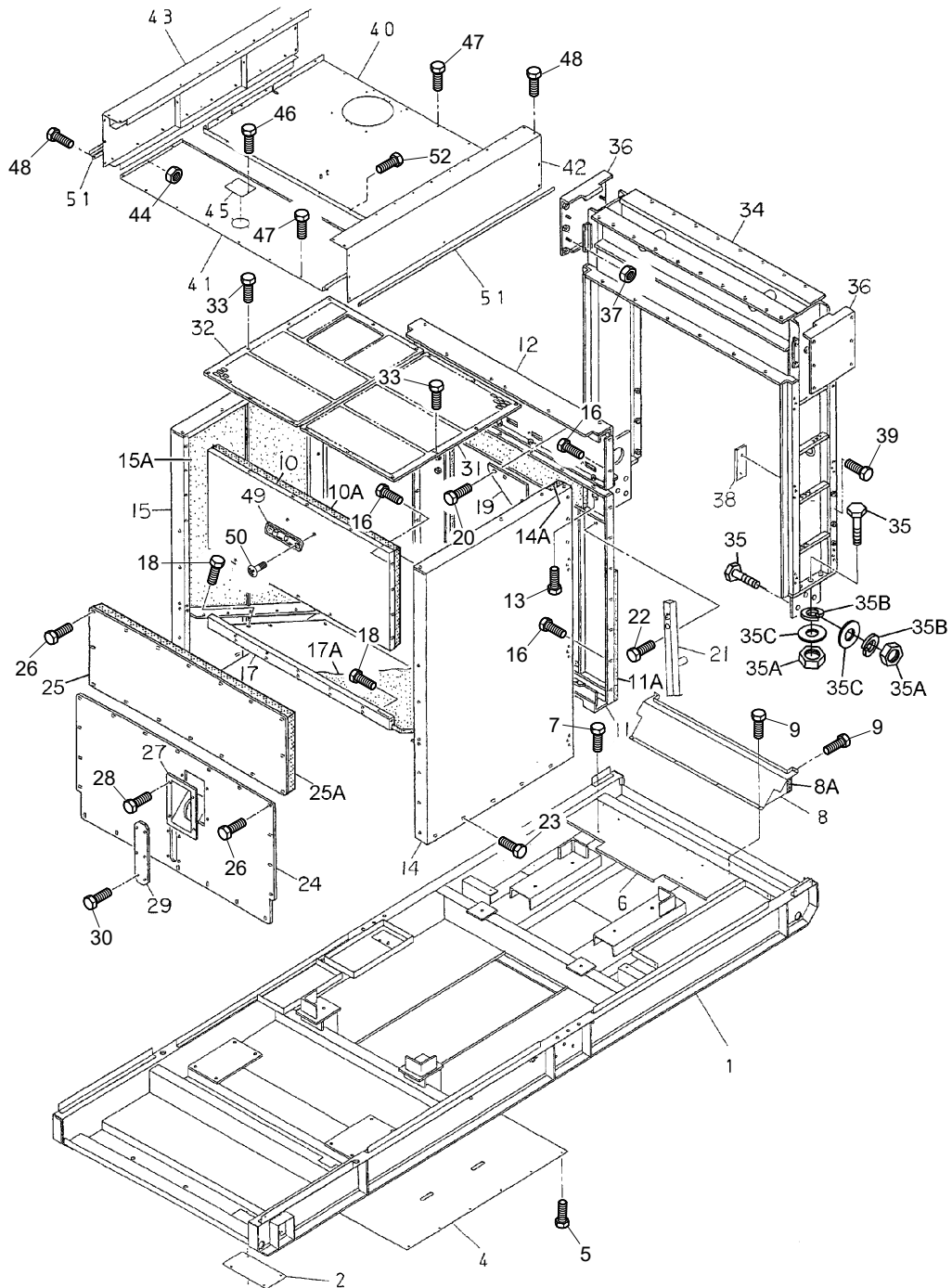

ENCLOSURE ASSY. #1 (CONT'D.)

<u>NO.</u>	<u>PART NO.</u>	<u>PART NAME</u>	<u>QTY.</u>	<u>REMARKS</u>
26	0019208020	HEX HEAD BOLT	36	
27	0845042703	FILLER BRACKET	1	
28	0019208020	HEX HEAD BOLT	4	
29	C4424204604	COVER	1	
30	0019206020	HEX HEAD BOLT	6	
31	C5424201903	FRONT FRAME COVER	1	
32	C5424202003	FRONT FRAME COVER	1	
33	0019208020	HEX HEAD BOLT	16	
34	C5434000702	CENTER FRAME	1	
35	0010120075	HEX HEAD BOLT	16	
35A	0040030000	HEX NUT	16	
35B	0040020000	WASHER, LOCK	16	
35C	0041620000	WASHER, FLAT	16	
36	C5434200003	COVER	2	
37	0207008000	HEX NUT	8	
38	C2367700404	COVER	1	
39	0019208020	HEX HEAD BOLT	2	
40	C5464101603	ROOF PANEL	1	
41	C5464101703	ROOF PANEL	1	
42	C5464101403	ROOF PANEL	1	
43	C5464101503	ROOF PANEL	1	
44	0207108000	HEX NUT	16	
45	8452023004	FILLER COVER	1	
46	0019208020	HEX HEAD BOLT	2	
47	0019208020	HEX HEAD BOLT	12	
48	0019210025	HEX HEAD BOLT	22	
49	0600500090	EMBLEM	1	
50	0021106016	MACHINE SCREW	2	
51	C5464500304	BRACKET	2	
52	0019206020	HEX HEAD BOLT	6	

ENCLOSURE ASSY. #2

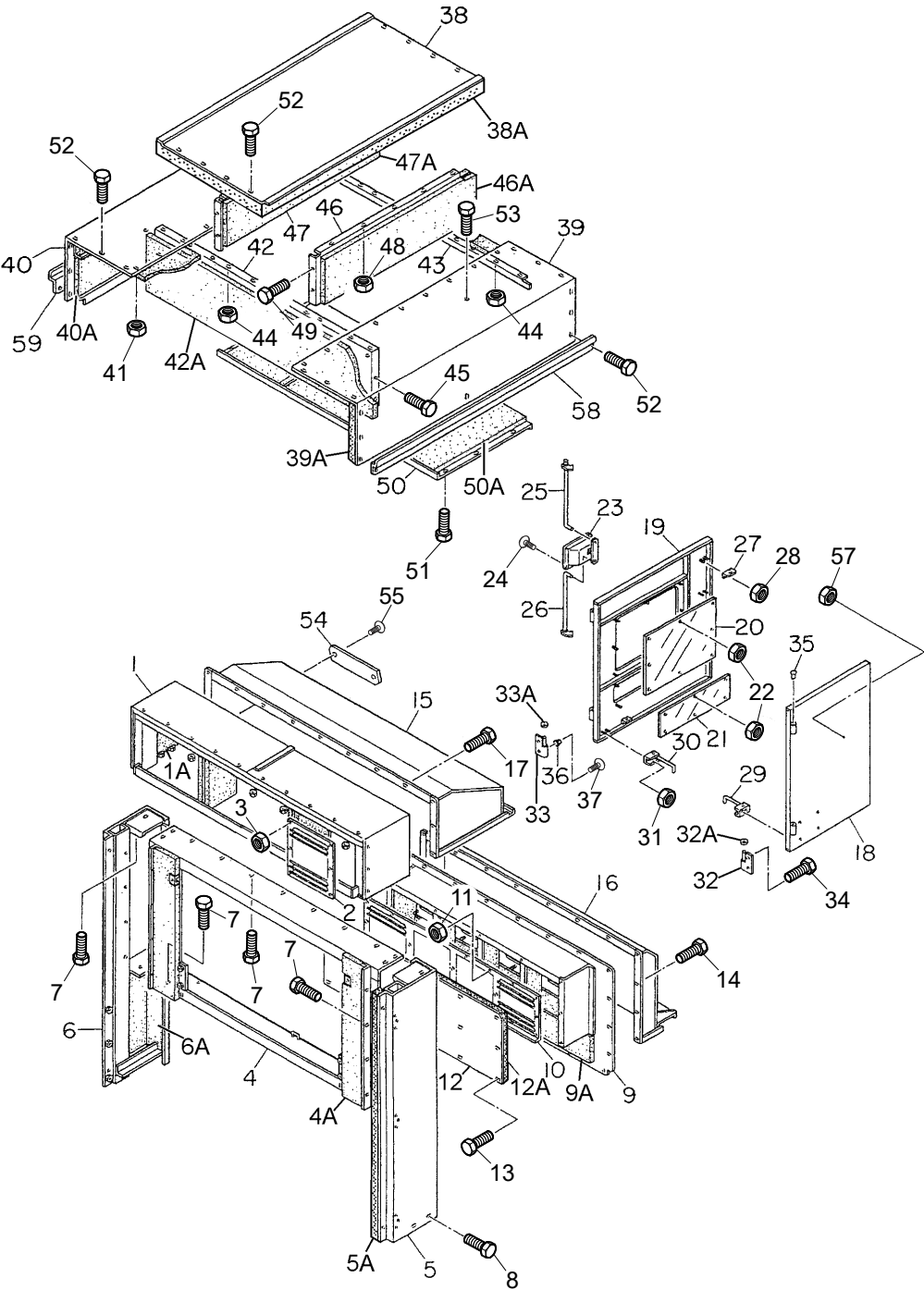

ENCLOSURE ASSY. #2

<u>NO.</u>	<u>PART NO.</u>	<u>PART NAME</u>	<u>QTY.</u>	<u>REMARKS</u>
1	C5444001403	REAR FRAME	1	
1A	C5494300104	LINING	1	
2	7525151004	LOUVER PANEL	5	
3	0207106000	HEX NUT	40	
4	C5444001303	REAR FRAME	1	
4A	C5494300604	LINING	1	
5	C5444001103	REAR FRAME	1	
5A	C5494300604	LINING	1	
6	C5444001203	REAR FRAME	1	
6A	C5494300604	LINING	1	
7	0017110020	HEX HEAD BOLT	21	
8	0019110025	HEX HEAD BOLT	4	
9	C5444300703	REAR FRAME COVER	1	
9A	C5494300704	LINING	1	
10	7525151804	LOUVER PANEL	1	
11	0207106000	HEX NUT	21	
12	C5444300804	DUCT COVER	1	
12A	C5494300804	LINING	1	
13	0017108020	HEX HEAD BOLT	15	
14	0019208020	HEX HEAD BOLT	21	
15	C5444300303	VISOR	1	
16	7525165603	VISOR	1	
17	0019208020	HEX HEAD BOLT	13	
18	C5444200503	REAR DOOR FRAME	1	
19	C5444200003	REAR DOOR FRAME	1	
20	7525147014	WINDOW PLATE	1	
21	7525147114	WINDOW PLATE	1	
22	0207306000	HEX NUT	14	
23	B9114000102	DOOR HANDLE	1	
24	0021806016	MACHINE SCREW	4	
25	7525146404	DOOR ROD	1	
26	7525146504	DOOR ROD	1	
27	0845050704	STAY	4	
28	0207106000	HEX NUT	8	
29	0805011304	DOOR STOPPER	1	
30	0805011204	DOOR STOPPER	1	
31	0207106000	HEX NUT	4	
32	0845047104	HINGE	2	
32A	0845045004	WASHER	2	
33	0845047204	HINGE	2	
33A	0845045004	WASHER	2	
34	0019208020	HEX HEAD BOLT	4	
35	0845031504	CAP	4	
36	0601850097	STOPPER	4	

ENCLOSURE ASSY. #2 (CONT'D.)

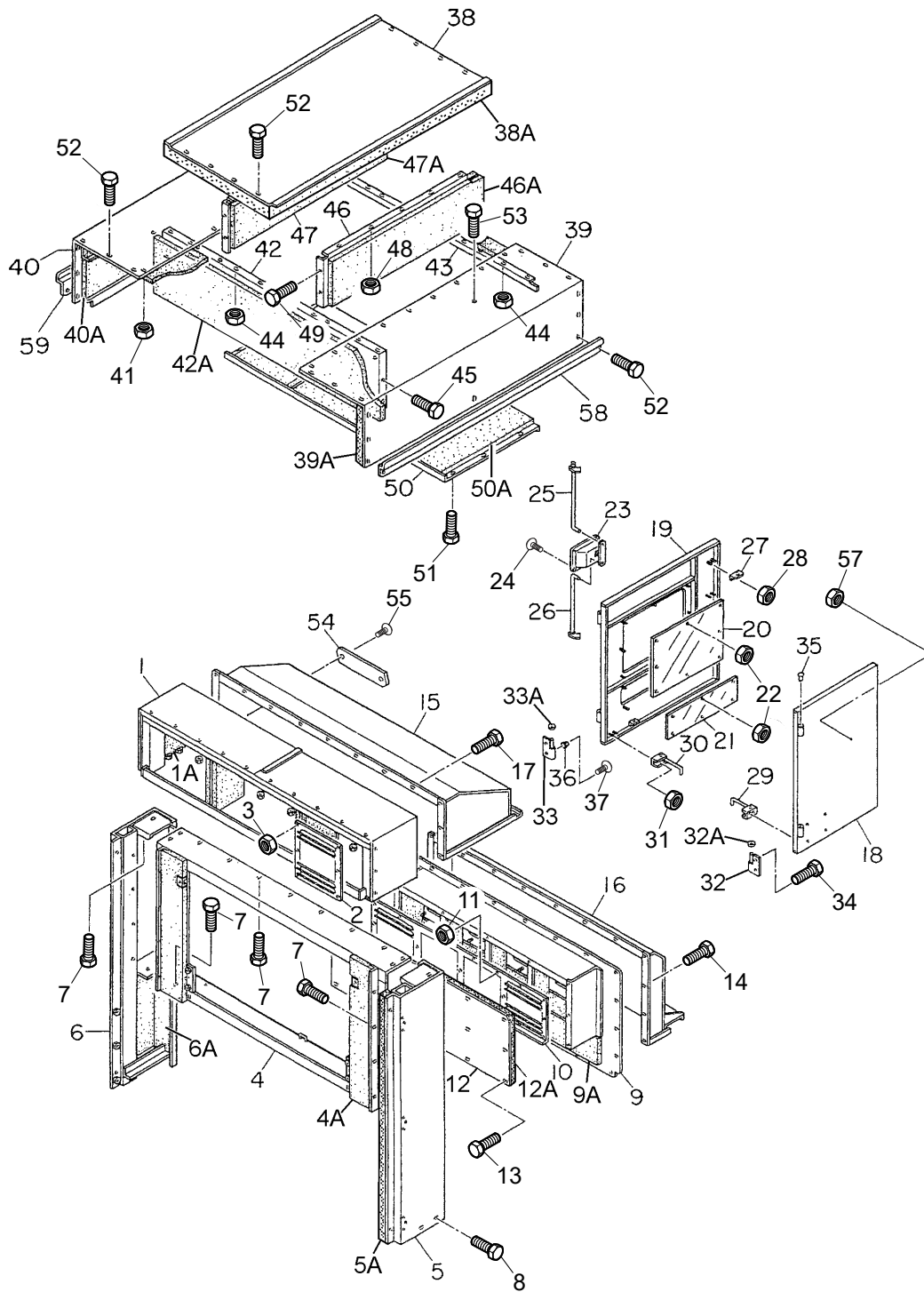

ENCLOSURE ASSY. #2 (CONT'D.)

<u>NO.</u>	<u>PART NO.</u>	<u>PART NAME</u>	<u>QTY.</u>	<u>REMARKS</u>
37	0025408025	MACHINE SCREW	4	
38	C5464201403	ROOF PANEL	1	
38A	C5494500503	LINING	1	
39	C5464201503	ROOF PANEL	1	
39A	C5494500503	LINING	1	
40	C5464201603	ROOF PANEL	1	
40A	C5494500503	LINING	1	
41	0207008000	HEX NUT	18	
42	C5464200504	PANEL	1	
42A	C5494500503	LINING	1	
43	C5464200604	GUIDE	1	
44	0207008000	HEX NUT	20	
45	0017108020	HEX HEAD BOLT	4	
46	C5464200404	PANEL	1	
46A	C5494500503	LINING	1	
47	C5464200304	PANEL	1	
47A	C5494500503	LINING	1	
48	0207008000	HEX NUT	10	
49	0017108020	HEX HEAD BOLT	4	
50	C5464400004	ROOF PANEL COVER	1	
50A	C5494500604	LINING	1	
51	0017108020	HEX HEAD BOLT	12	
52	0019210030	HEX HEAD BOLT	34	
53	0019212030	HEX HEAD BOLT	4	
54	0600500090	EMBLEM	1	
55	0021106016	MACHINE SCREW	2	
57	0207106000	HEX NUT	4	
58	C5464500404	BRACKET	1	
59	C5464500504	BRACKET	1	

ENCLOSURE ASSY. #3

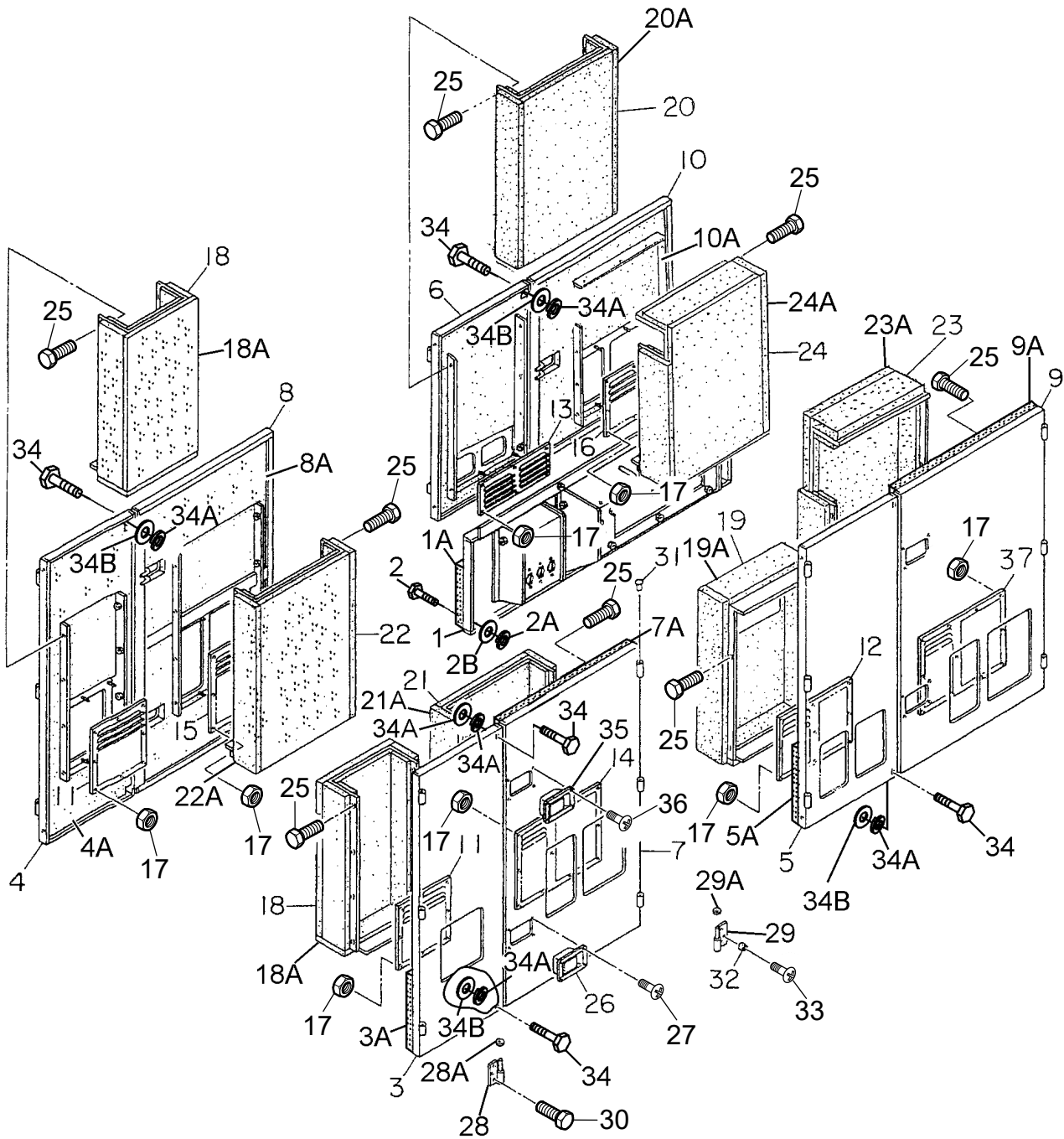

ENCLOSURE ASSY. #3

<u>NO.</u>	<u>PART NO.</u>	<u>PART NAME</u>	<u>QTY.</u>	<u>REMARKS</u>
1	C5454202603	SPLASHER PANEL	1	
1A	C5494405704	LINING	1	
2	0019110065	HEX HEAD BOLT	6	
2A	0042310000	WASHER, LOCK	6	
2B	0042410000	WASHER, FLAT	6	
3	C5454101703	SIDE PANEL	1	
3A	C5494400904	LINING	1	
4	C5454101803	SIDE PANEL	1	
4A	C5494405004	LINING	1	
5	C5454101903	SIDE PANEL	1	
5A	C5494405104	LINING	1	
6	C5454102003	SIDE PANEL	1	
6A	C5494405204	LINING	1	
7	C5454001903	SIDE DOOR	1	
7A	C5494404504	LINING	1	
8	C5454002003	SIDE DOOR	1	
8A	C5494404604	LINING	1	
9	C5454002103	SIDE DOOR	1	
9A	C5494404704	LINING	1	
10	C5454002203	SIDE DOOR	1	
10A	C5494404804	LINING	1	
11	C5454700304	LOUVER PANEL	2	
12	7525151604	LOUVER PANEL	1	
13	C5454700404	LOUVER PANEL	1	
14	7525151304	LOUVER PANEL	1	
15	7525151404	LOUVER PANEL	1	
16	C5454700204	LOUVER PANEL	1	
17	0207106000	HEX NUT	74	
18	C5454301004	DUCT	2	
18A	C5494405504	LINING	1	
18B	C5494405804	LINING	1	
19	C5454300704	DUCT	1	
19A	C5494403904	LINING	1	
20	C5454301104	DUCT	1	
20A	C5494405604	LINING	1	

ENCLOSURE ASSY. #3 (CONT'D.)

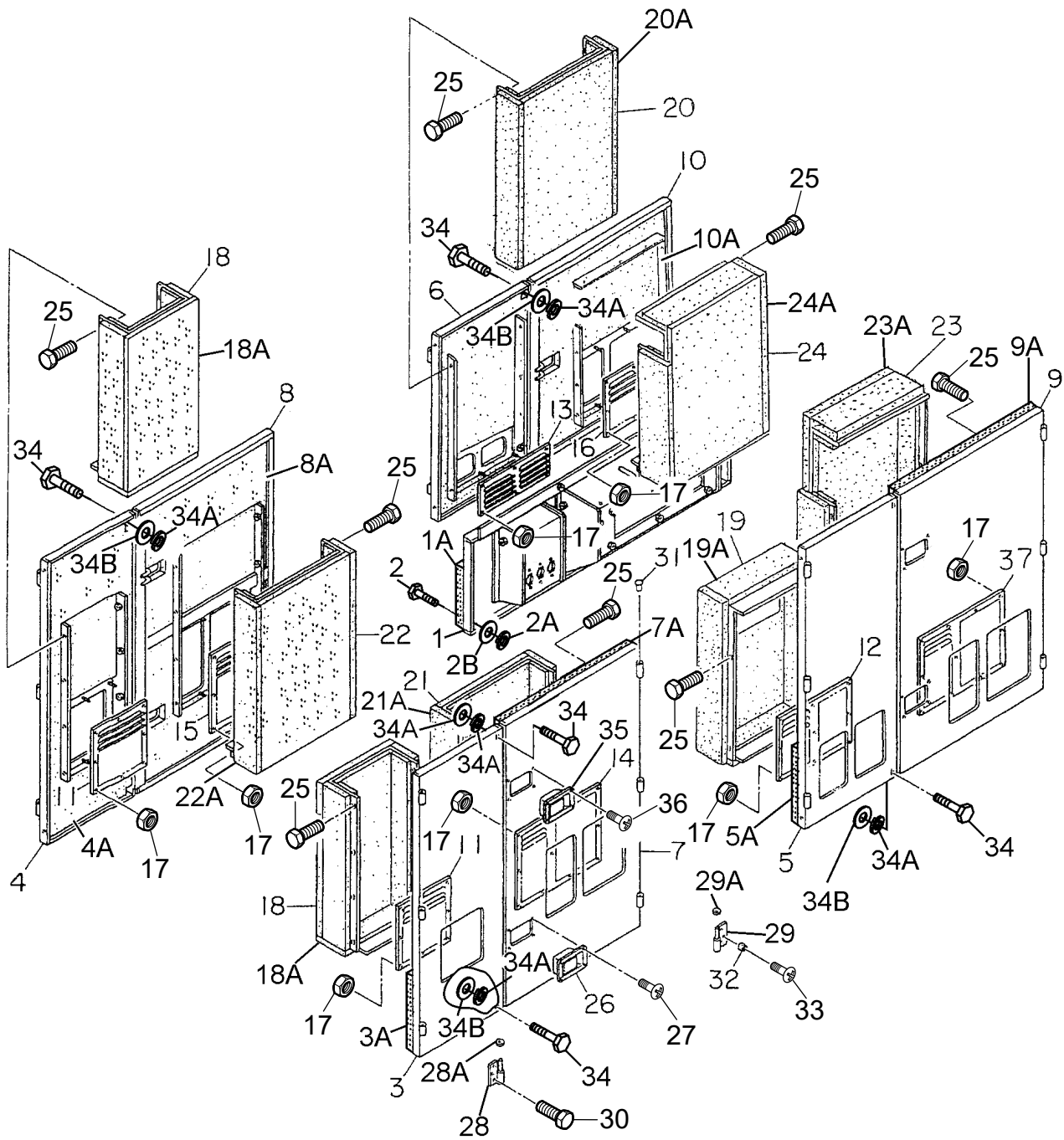

ENCLOSURE ASSY. #3 (CONT'D.)

<u>NO.</u>	<u>PART NO.</u>	<u>PART NAME</u>	<u>QTY.</u>	<u>REMARKS</u>
21	C5454300604	DUCT	1	
21A	C5494405904	LINING	1	
22	C5454300904	DUCT	1	
22A	C5494405904	LINING	1	
23	C5454300804	DUCT	1	
23A	C5494405304	LINING	1	
24	C5454300904	DUCT	1	
24A	C5494405404	LINING	1	
25	0019208020	HEX HEAD BOLT	71	
26	0825007362	DOOR HANDLE	3	
27	0021806016	MACHINE SCREW	12	
28	0845046904	HINGE	11	
28A	0845045004	WASHER	11	
29	0845049004	HINGE	11	
29A	0845045004	WASHER	11	
30	0019208020	HEX HEAD BOLT	44	
31	0845031504	CAP	22	
32	0601850097	STOPPER	16	
33	0025408025	MACHINE SCREW	22	
34	0019110065	HEX HEAD BOLT	8	
34A	0042310000	WASHER, LOCK	8	
34B	0042410000	WASHER, FLAT	8	
35	B9114000002	DOOR HANDLE	4	
36	0021806016	MACHINE SCREW	16	
37	C5454700104	LOUVER PANEL	1	

RUBBER SEALS ASSY.

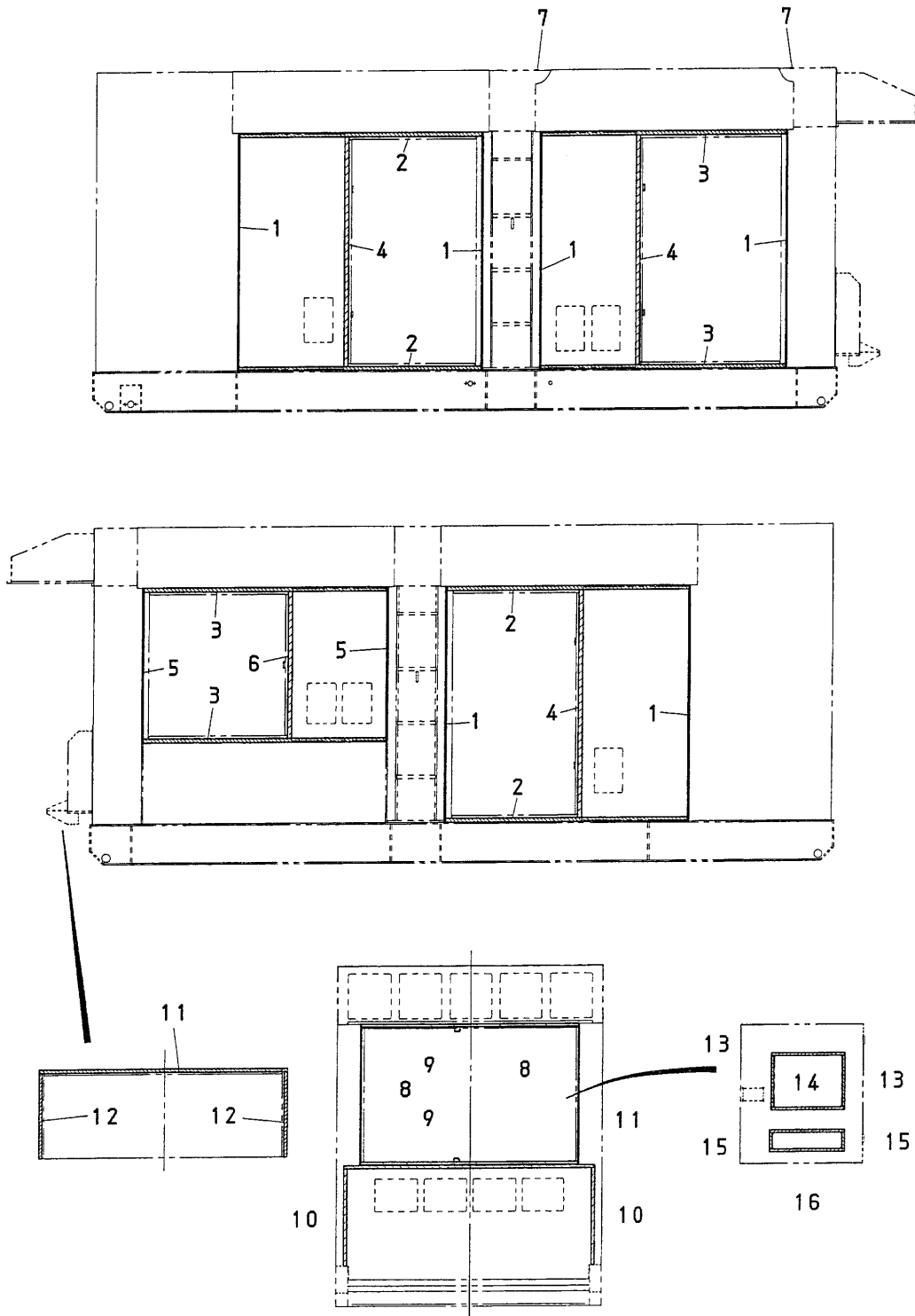

RUBBER SEALS ASSY.

<u>NO.</u>	<u>PART NO.</u>	<u>PART NAME</u>	<u>QTY.</u>	<u>REMARKS</u>
1	0228901750	RUBBER SEAL	6	
2	0228901780	RUBBER SEAL	4	
3	0228901800	RUBBER SEAL	4	
4	0228901690	RUBBER SEAL	3	
5	0228901150	RUBBER SEAL	2	
6	0228801090	RUBBER SEAL	1	
7	0229201950	RUBBER SEAL	2	
8	0221201030	RUBBER SEAL	2	
9	0228801600	RUBBER SEAL	2	
10	0229200710	RUBBER SEAL	2	
11	0229201840	RUBBER SEAL	2	
12	0229200625	RUBBER SEAL	2	
13	0228100380	RUBBER SEAL	2	
14	0228100550	RUBBER SEAL	2	
15	0228100120	RUBBER SEAL	2	
16	0228100560	RUBBER SEAL	2	

NAMEPLATE AND DECALS ASSY. #1

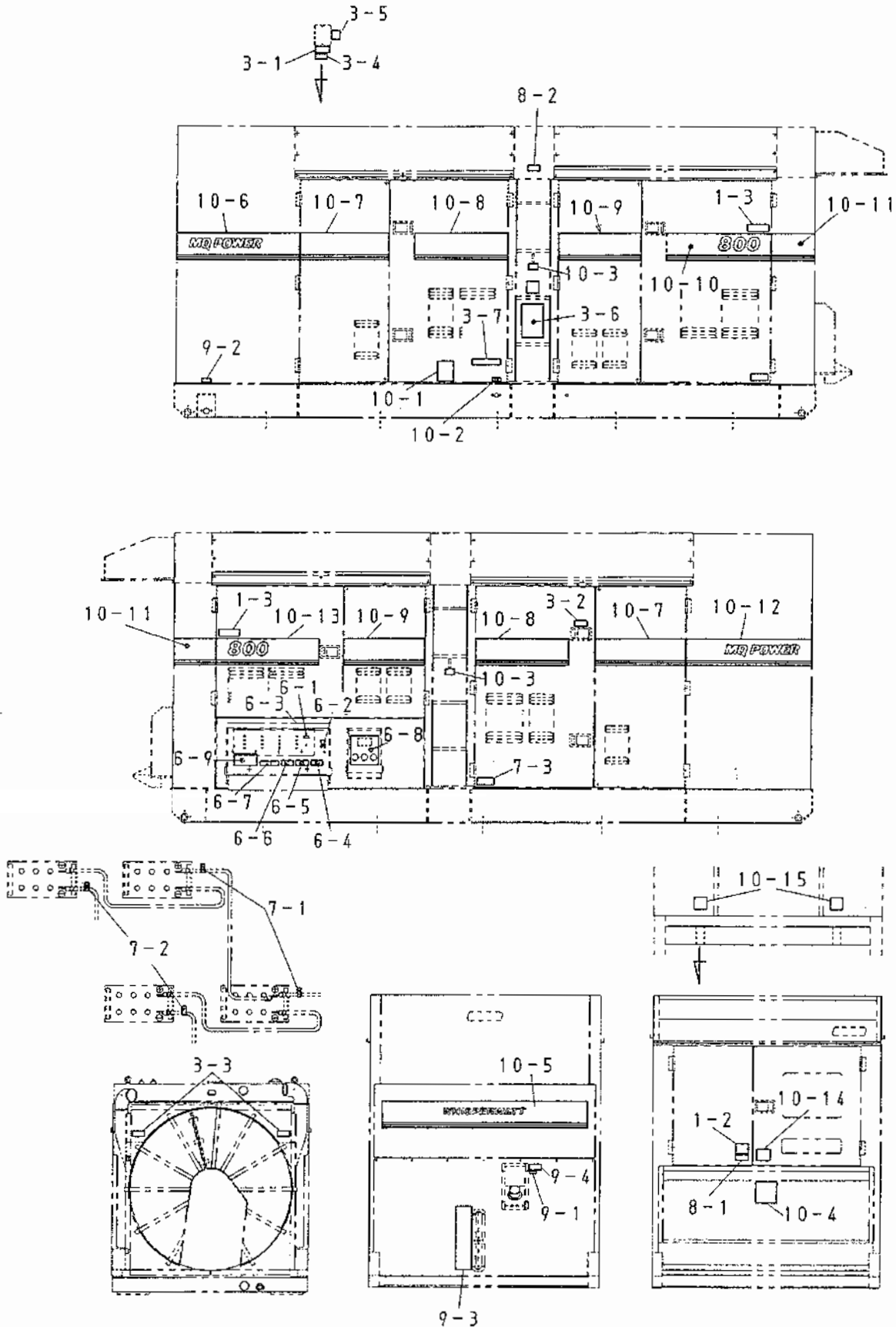

NAMEPLATE AND DECALS ASSY. #1

<u>NO.</u>	<u>PART NO.</u>	<u>PART NAME</u>	<u>QTY.</u>	<u>REMARKS</u>
1-2	B9521100404	DECAL : SAFETY INSTRUCTIONS.....	1.....	B92110040
1-3	B1552000103	DECAL : CAUTION	2.....	B15200010s
ENGINE AND RADIATOR GROUP				
3-1	0800689204	DECAL : COOLING WATER	1.....	S961
3-2	B9504000304	DECAL : CAUTION HOT PARTS	1.....	B90400030
3-3	B9504000404	DECAL : WARNING MOVING PARTS	2.....	B90400040
3-4	B9504100104	DECAL : WARNING HOT COOLANT	1.....	B90410010
3-5	0600501100	DECAL : WARNING	1.....	0600501100
3-6	0966810000	DECAL : FUEL PRIMING	1	
OUTPUT TERMINAL GROUP				
6-1	0840614104	DECAL : GROUND.....	1.....	S2635
6-2	9039209064	DECAL : START CONTACT	1.....	S4468
6-3	0840655704	DECAL : TERMINAL COVER STOPPER.....	1.....	S4516
6-4	B9511100304	DECAL : WARNING	1.....	B91110030
6-5	B9511100404	DECAL : WARNING ELECTRIC SHOCK HAZARD	1.....	B93110050
6-6	B9531100504	DECAL : WARNING ELECTRIC SHOCK HAZARD	1.....	B93110050
6-7	C0551000404	DECAL : 3 PHASE OUTPUT TERMINAL.....	1.....	C05100040
6-8	C5551000403	DECAL : RECEPTACLE AND CIRCUIT BREAKER.....	1.....	C55100040
6-9	0840619904	DECAL : DANGER HIGH VOLTAGE.....	1.....	S2731
BATTERY GROUP				
7-1	0800689404	DECAL : +	2.....	S2090
7-2	0800689504	DECAL : -	2.....	S2091
7-3	C9505300004	DECAL : CAUTION	1.....	C90530000
MUFFLER GROUP				
8-1	B9504200004	DECAL : WARNING ENGINE EXHAUST.....	1.....	B90420000
8-2	B9511100204	DECAL : CAUTION HOT SURFACES	1.....	B91110020
FUEL TANK GROUP				
9-1	1320620904	DECAL : DIESEL FUEL.....	1.....	S1756
9-2	6360620004	DECAL : FUEL DRAIN PLUG.....	1.....	S1883
9-3	0840607104	DECAL : FUEL GAUGE.....	1.....	S2365
9-4	B9504500004	DECAL : WARNING DIESEL FUEL.....	1.....	B90450000
BONNET GROUP				
10-1	0800615102	DECAL : CAUTION AGAINST OIL AND	1.....	S544A
10-2	1320610603	DECAL : WATER • OIL	1.....	S1760
10-3	1320621504	DECAL : SUPPORT HOOK.....	2.....	S2257
10-4	0840625902	DECAL : MQ.....	1.....	S3057

NAMEPLATE AND DECALS ASSY. #1 (CONT'D.)

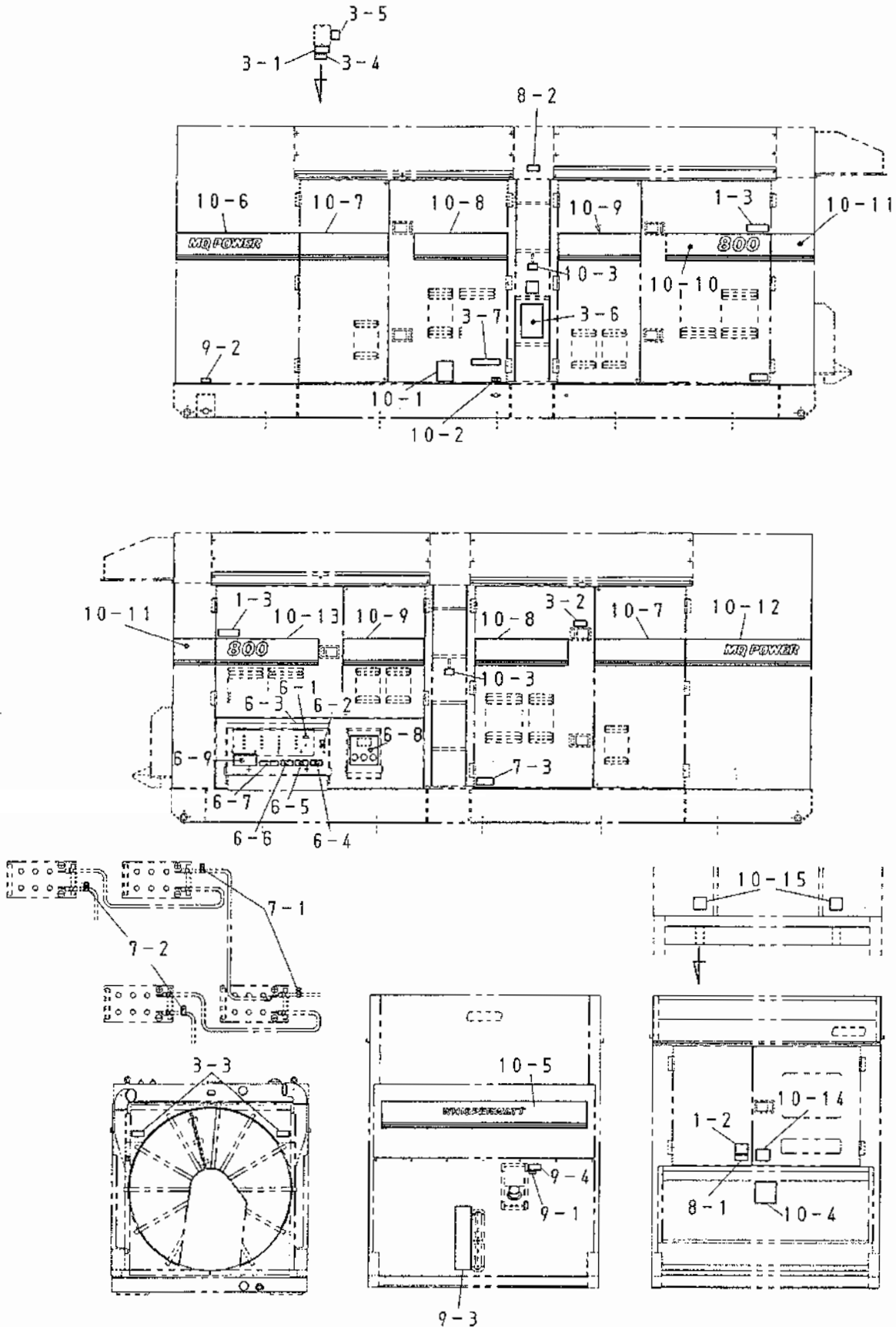

NAMEPLATE AND DECALS ASSY. #1 (CONT'D.)

<u>NO.</u>	<u>PART NO.</u>	<u>PART NAME</u>	<u>QTY.</u>	<u>REMARKS</u>
10-5	C5561100703	DECAL : MQ.....	1.....	S3057
10-6	C5561101703	STRIPE	1	
10-7	C4561101404	STRIPE	2	
10-8	C5561101804	STRIPE	2	
10-9	C5561101304	STRIPE	2	
10-10	C5561101603	STRIPE	1	
10-11	C5561101104	STRIPE	2	
10-12	C5561101504	STRIPE	1	
10-13	C5561101204	STRIPE	1	
10-14	A9504000014	DECAL : DANGER	1.....	A90400001
10-15	C9511100804	DECAL : CAUTION	2.....	C91110080

NAMEPLATE AND DECALS ASSY. #2

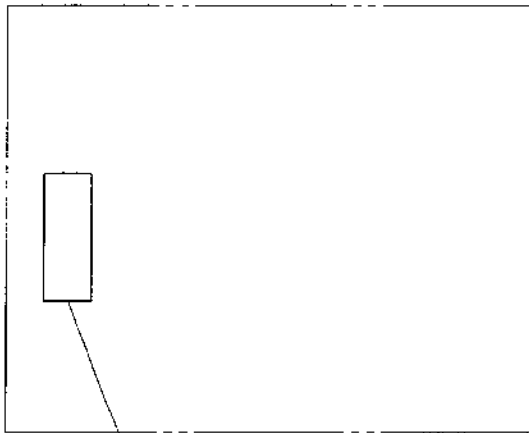

2-11

VIEW - Z

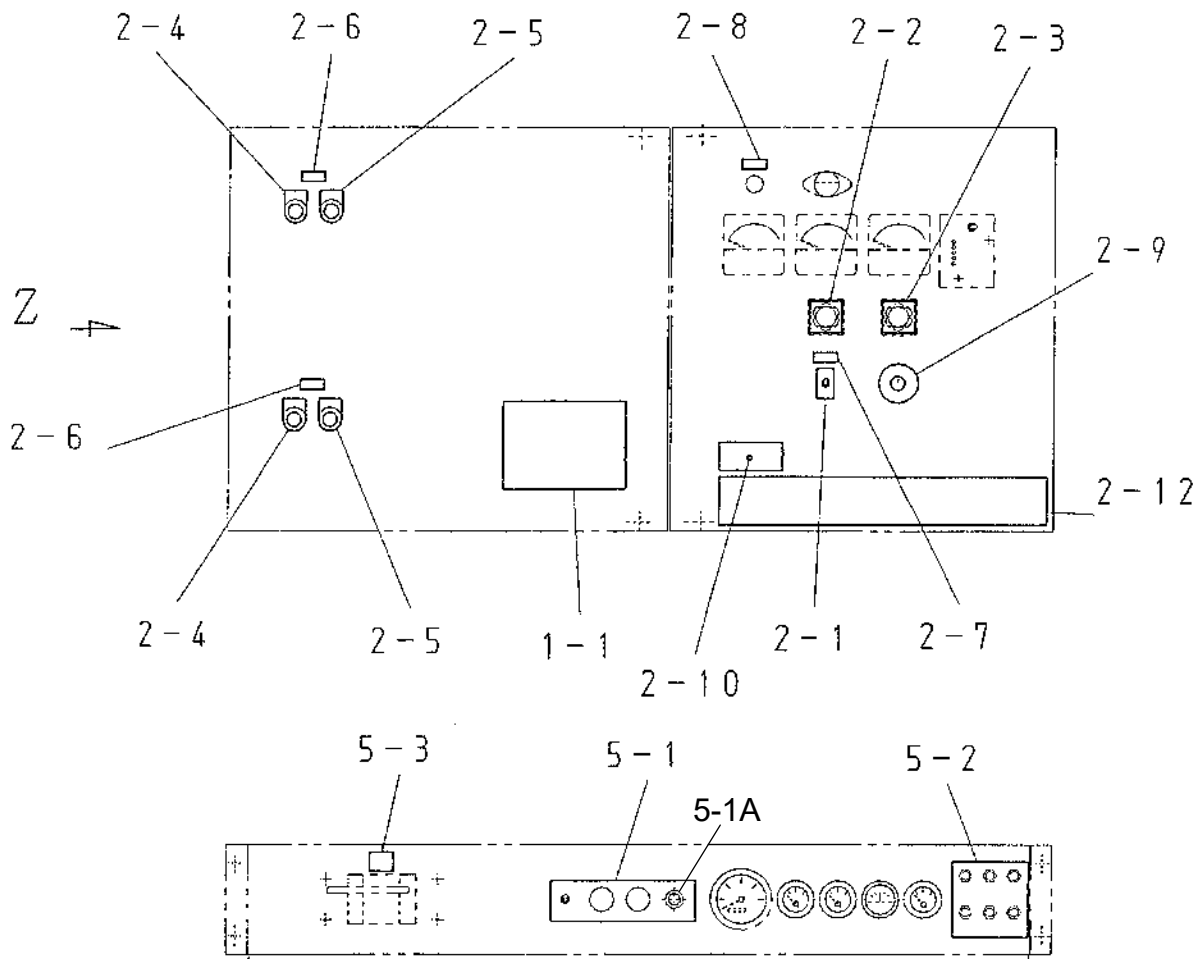

NAMEPLATE AND DECALS ASSY. #2

<u>NO.</u>	<u>PART NO.</u>	<u>PART NAME</u>	<u>QTY.</u>	<u>REMARKS</u>
1-1	C1552000403	DECAL : HANDLING PROCEDURES.....	1.....	C15200040
CONTROL PANEL AND BOX GROUP				
2-1	0800520100	PLATE : ON OFF	1.....	AT 202
2-2	0800520904	PLATE : AMMETER CHANGE OVER SWITCH.....	1.....	N2438
2-3	0800520814	PLATE : VOLTMETER CHANGE OVER SWITCH.....	1.....	N2439
2-4	0800564004	PLATE : OFF	2.....	N3805
2-5	0800565004	PLATE : ON	2.....	N3806
2-6	0840624504	DECAL : CIRCUIT BREAKER.....	2.....	S3031
2-7	0840624604	DECAL : PANEL LIGHT SWITCH	1.....	S3032
2-8	0840624704	DECAL : PILOT LAMP.....	1.....	S3033
2-9	0840624804	DECAL : VOLTAGE REGULATOR.....	1.....	S3034
2-10	B9531100604	DECAL : WARNING ELECTRIC SHOCK HAZARD	2.....	B93110060
2-11	C5551000303	DECAL : SETTING FOR OUTPUT VOLTAGE	1.....	C55100030
2-12	C5561101003	DECAL : WHISPERWATT 800	1.....	C56110010
ENGINE OPERATING PANEL GROUP				
5-1	C5551001203	DECAL : OPERATING PANEL	1.....	C55100120
5-1A	0840647804	DECAL : EMERGENCY STOP	1.....	S4100
5-2	C5551001104	DECAL : WARNING LAMP.....	1.....	C55100110A
5-3	C0551000504	DECAL : BATTERY SWITCH	1.....	C05100050

PARTS MANUAL

HERE'S HOW TO GET HELP

PLEASE HAVE THE MODEL AND SERIAL
NUMBER ON HAND WHEN CALLING

UNITED STATES

Multiquip Inc.

(310) 537- 3700
6141 Katella Avenue Suite 200
Cypress, CA 90630
E-MAIL: mq@multiquip.com
WEBSITE: www.multiquip.com

CANADA

Multiquip

(450) 625-2244
4110 Industriel Boul.
Laval, Quebec, Canada H7L 6V3
E-MAIL: infocanada@multiquip.com

UNITED KINGDOM

Multiquip (UK) Limited Head Office

0161 339 2223
Unit 2, Northpoint Industrial Estate, Globe Lane,
Dukinfield, Cheshire SK16 4UJ
E-MAIL: sales@multiquip.co.uk

© COPYRIGHT 2024, MULTIQUIP INC.

Multiquip Inc, the MQ logo and the MQ Power logo are registered trademarks of Multiquip Inc. and may not be used, reproduced, or altered without written permission. All other trademarks are the property of their respective owners and used with permission.

This manual MUST accompany the equipment at all times. This manual is considered a permanent part of the equipment and should remain with the unit if resold.

The information and specifications included in this publication were in effect at the time of approval for printing. Illustrations, descriptions, references and technical data contained in this manual are for guidance only and may not be considered as binding. Multiquip Inc. reserves the right to discontinue or change specifications, design or the information published in this publication at any time without notice and without incurring any obligations.

Manufactured for
MQ Power Inc.
by
DENYO MANUFACTURING CORP.

