

PARTS MANUAL



MODEL DLW-300ES
MODEL DLW-300ESA
MODEL DLW-300ESA1
WELDER/GENERATOR
(KUBOTA D722/E2B/E3B DIESEL ENGINE)

REF. NO.

D4844300604 - DLW-300ES

D4844301114C - DLW-300ESA

D4844301114G - DLW-300ESA1

Revision #7 (06/30/26)

To find the latest revision of this publication or associated operation manual, visit our website at: www.multiquip.com



DLW300ES/ESA/ESA1 Generator Welder

Explanation of Code in Remarks Column.....	4
Suggested Spare Parts	5

Component Drawings

Generator Assembly	6–7
Control Panel Assy. (DLW-300ES)	8–9
Control Panel Assy. (DLW-300ESA/ESA1).....	10–13
Electric Parts 1 Assy. (DLW-300ES).....	14–15
Electric Parts 2 Assy. (DLW-300ES).....	16–17
Electric Parts 3 Assy. (DLW-300ES).....	18–19
Electric Parts 1 Assy. (DLW-300ESA/ESA1) ...	20–23
Electric Parts 2 Assy. (DLW-300ESA/ESA1) ...	24–25
Engine and Radiator Assembly	26–29
Battery Assembly	30–31
Muffler Assembly	32–33
Fuel Tank Assembly.....	34–35
Enclosure Assembly	36–39
Rubber Seals Assembly	40–41
Nameplate and Decals Assembly.....	42–45

NOTICE

Specifications and part numbers are subject to change without notice.

EXPLANATION OF CODE IN REMARKS COLUMN

The following section explains the different symbols and remarks used in the Parts section of this manual. Use the help numbers found on the back page of the manual if there are any questions.

NOTICE

The contents and part numbers listed in the parts section are subject to change without notice. Multiquip does not guarantee the availability of the parts listed.

SAMPLE PARTS LIST

NO.	PART NO.	PART NAME	QTY.	REMARKS
1	12345	BOLT	1	INCLUDES ITEMS W/%
2%		WASHER, 1/4 IN.		NOT SOLD SEPARATELY
2%	12347	WASHER, 3/8 IN. ...	1	MQ-45T ONLY
3	12348	HOSE	A/R	MAKE LOCALLY
4	12349	BEARING	1	S/N 2345B AND ABOVE

NO. Column

Unique Symbols — All items with same unique symbol (@, #, +, %, or >) in the number column belong to the same assembly or kit, which is indicated by a note in the “Remarks” column.

Duplicate Item Numbers — Duplicate numbers indicate multiple part numbers, which are in effect for the same general item, such as different size saw blade guards in use or a part that has been updated on newer versions of the same machine.

NOTICE

When ordering a part that has more than one item number listed, check the remarks column for help in determining the proper part to order.

PART NO. Column

Numbers Used — Part numbers can be indicated by a number, a blank entry, or TBD.

TBD (To Be Determined) is generally used to show a part that has not been assigned a formal part number at the time of publication.

A blank entry generally indicates that the item is not sold separately or is not sold by Multiquip. Other entries will be clarified in the “Remarks” Column.

QTY. Column

Numbers Used — Item quantity can be indicated by a number, a blank entry, or A/R.

A/R (As Required) is generally used for hoses or other parts that are sold in bulk and cut to length.

A blank entry generally indicates that the item is not sold separately. Other entries will be clarified in the “Remarks” Column.

REMARKS Column

Some of the most common notes found in the “Remarks” Column are listed below. Other additional notes needed to describe the item can also be shown.

Assembly/Kit — All items on the parts list with the same unique symbol will be included when this item is purchased.

Indicated by:

“INCLUDES ITEMS W/(unique symbol)”

Serial Number Break — Used to list an effective serial number range where a particular part is used.

Indicated by:

“S/N XXXXX AND BELOW”

“S/N XXXX AND ABOVE”

“S/N XXXX TO S/N XXX”

Specific Model Number Use — Indicates that the part is used only with the specific model number or model number variant listed. It can also be used to show a part is NOT used on a specific model or model number variant.

Indicated by:

“XXXXX ONLY”

“NOT USED ON XXXX”

“Make/Obtain Locally” — Indicates that the part can be purchased at any hardware shop or made out of available items. Examples include battery cables, shims, and certain washers and nuts.

“Not Sold Separately” — Indicates that an item cannot be purchased as a separate item and is either part of an assembly/kit that can be purchased, or is not available for sale through Multiquip.

SUGGESTED SPARE PARTS

DLW-300ES/ESA/ESA1 WITH KUBOTA D722-E2B-WDDE-2/D722-E3B-WDDE-2 DIESEL ENGINES

1 to 3 units

Qty.	P/N	Description
5	0602041270	CARTRIDGE, OIL FILTER
1	D4311500003	HOSE, RADIATOR, UPPER
1	D4311500103	HOSE, RADIATOR, LOWER
1	0602011064	CAP, RADIATOR (DLW300ES)
1	0602011079	CAP, RADIATOR (DLW300ESA)
1	0810100813	CAP, FUEL TANK
1	1522139013	SWITCH, OIL
6	1553143010	FILTER, FUEL
6	1523143560	FILTER, FUEL ELEMENT
3	0602046611	FILTER, AIR ELEMENT
1	0602011470	FAN BELT
1	0601808254	CIRCUIT BREAKER, 2P, @ 42A (DLW300ES)
1	0601806472	CIRCUIT BREAKER, 2P, @ 40A (DLW300ESA)
1	0601806420	CIRCUIT BREAKER, 1P, @ 20A (DLW300ES)
1	0601806423	CIRCUIT BREAKER, 1P, @ 20A (DLW300ESA)
1	0601806421	CIRCUIT BREAKER, 1P, @ 30A (DLW300ES)
1	0601806424	CIRCUIT BREAKER, 1P, @ 30A (DL300ESA)
1	0601806422	CIRCUIT BREAKER, 2P, @ 30A (DLW300ES)
1	0601806425	CIRCUIT BREAKER, 2P, @ 30A (DLW300ESA)
1	0601820664	AUTOMATIC VOLTAGE REGULATOR
1	0601840028	RHEOSTAT (CURRENT/VOLTAGE REGULATOR 500W)
1	0601840103	KNOB, RHEOSTAT (CURRENT/VOLTAGE REGULATOR)
1	0601840095	RHEOSTAT (ARC FORCE TRIMMER)
1	0601840170	KNOB, RHEOSTAT (RHEOSTAT (ARC FORCE TRIMMER)
5	0601806642	FUSE, 5A
5	0601806643	FUSE, 15A
5	0601806644	FUSE, 30A
5	0601806640	FUSE, 65A

NOTICE

Part numbers on this Suggested Spare Parts list may supersede/replace the part numbers shown in the following parts lists.

GENERATOR ASSY.

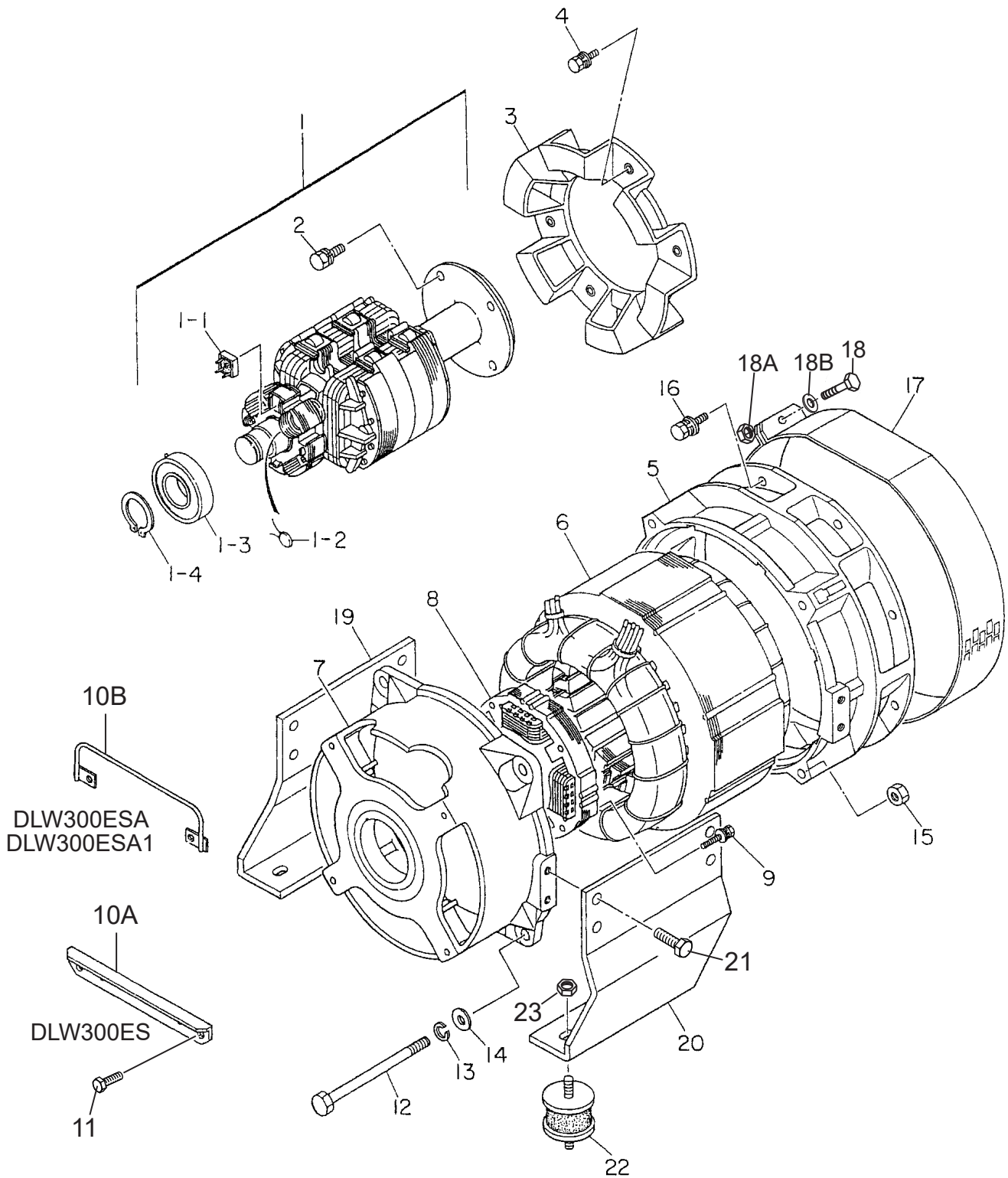

GENERATOR ASSY.

<u>NO.</u>	<u>PART NO.</u>	<u>PART NAME</u>	<u>QTY.</u>	<u>REMARKS</u>
1	D4110000203	ROTOR ASSY.....	1.....	INCLUDES ITEM W/%
1-1%	0601820037	RECTIFIER	1	
1-2%	0601822638	SURGE ABSORBER, (DLW-300ES)	1	
1-2%	0601822638	SURGE ABSORBER, (DLW-300ESA,ESA1).....	1.....	SN 5853021 AND BELOW
1-2%	Y0601822692	SURGE ABSORBER, (DLW-300ESA/ESA1).....	1.....	SN 5853022 AND ABOVE
1-3%	0071206307	BEARING	1	
1-4%	0080000035	SNAP RING	1	
2%	0012410030	HEX. HEAD BOLT	4	
3	D4111100103	FAN	1	
4	011208025	HEX. HEAD BOLT.....	6.....	REPLACES P/N 0017108025
5	D4153100102	END BRACKET	1	
6	D4135000503	ARMATURE ASSY., (DLW-300ES)	1	
6	D4135001203	ARMATURE ASSY., (DLW-300ESA/ESA1)	1	
7	D4153000202	END BRACKET	1	
8	D4139000003	FIELD ASSY., EXCITER	1	
9	0017105035	HEX. HEAD BOLT	4	
10A	D4155300104	BRACKET, (DLW-300ES)	1	
10B	D4185300004	BRACKET, (DLW-300ESA, ESA1)	1	
11	011008020	HEX. HEAD BOLT.....	2.....	REPLACES P/N 0016908020
12	D4131200004	SET BOLT	4	
13	0040012000	WASHER, LOCK	4	
14	031112230	WASHER, FLAT.....	4.....	REPLACES P/N 0041212000
15	0030012000	HEX. NUT	4	
16	0012410025	HEX. HEAD BOLT	8	
17	D4155400204	COVER, FAN	1	
18	0017106040	HEX. HEAD BOLT, (DLW-300ES, ESA1)	1	
18	0340406040	HEX. HEAD BOLT, (DLW-300ESA)	1	
18A	020106050	HEX. NUT.....	1.....	REPLACES P/N 0037906000
18B	952404470	WASHER, FLAT, (DLW-300ESA).....	1.....	REPLACES P/N 0041206000
19	D4132100103	GENERATOR FOOT	1	
20	D4132100003	GENERATOR FOOT	1	
21	012210025	HEX. HEAD BOLT, (DLW-300ES).....	8.....	REPLACES P/N 0012310025
21	Y0011210025	HEX. HEAD BOLT, (DSW-300ESA/ESA1)	8	
22	7605419004A	RUBBER SUSPENSION.....	2.....	REPLACES P/N 7605419004
23	021112140	HEX. NUT.....	2.....	REPLACES P/N 0207010000

DLW-300ES — CONTROL PANEL ASSY.

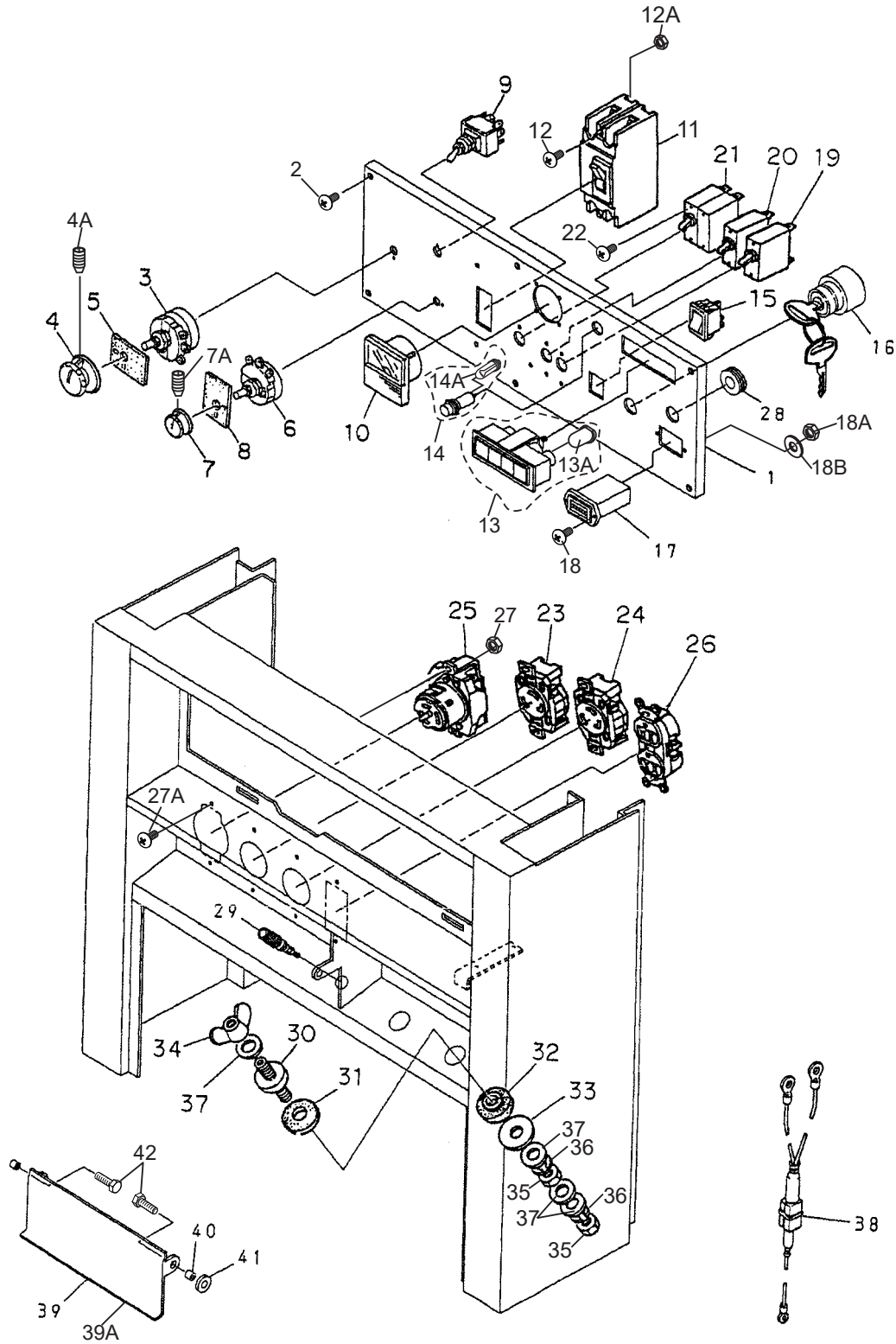

DLW-300ES — CONTROL PANEL ASSY.

<u>NO.</u>	<u>PART NO.</u>	<u>PART NAME</u>	<u>QTY.</u>	<u>REMARKS</u>
1	D4224000503	CONTROL PANEL	1	
2	0021806030	MACHINE SCREW	6	
3	0601840028	RHEOSTAT (CURRENT REGULATOR)	1	
4	0601840103	KNOB	1	
4A	0023304008	SET SCREW	2	
5	0801883003	INSULATOR	1	
6	0601840095	RHEOSTAT (ARC FORCE REGULATOR)	1	
7	0601840100	KNOB	1	
7A	0023303508	SET SCREW	2	
8	0801883003	INSULATOR	1	
9	0601831309	SWITCH, E-MODE	1	
10	0601800281	AC VOLTMETER, 5A 0~150/300V	1	
11	0601808254	CIRCUIT BREAKER, 2P, 42A	1	
12	0027104070	MACHINE SCREW	2	
12A	0038704000	HEX. NUT	2	
13	0601810523	INDICATOR ASSY.....	1	INCLUDES ITEM W/%
13A%	0601810207	BULB	4	
14	0602103098	WARNING LAMP	1	INCLUDES ITEM W/#
14A#	0601810248	BULB	1	
15	0601831620	SWITCH, IDLE CONTROL	1	
16	1628663602	STARTER SWITCH	1	REPLACES P/N 3741059113
17	0601800682	HOUR METER, DC10-32V	1	
18	0027103512	MACHINE SCREW	2	
18A	0030003500	HEX. NUT	2	
18B	0040403500	WASHER	2	
19	0601806420	CIRCUIT BREAKER, CB4, 1P, 20A	1	
20	0601806421	CIRCUIT BREAKER, CB3, 1P, 30A	1	
21	0601806422	CIRCUIT BREAKER, CB2, 2P, 30A	1	
22	0027103006	MACHINE SCREW	6	
23	0601811033	RECEPTACLE, L6-30R	1	
24	0601811035	RECEPTACLE, L5-30R	1	
25	0601812565	RECEPTACLE, CS6369	1	
26	0601812598	RECEPTACLE, 5-20R	1	
27	0038704000	HEX. NUT	8	
27A	0027104016	MACHINE SCREW	8	
28	0601850290	GROMMET	1	
29	0601815109	GROUND TERMINMAL	1	
30	0801888204	OUTPUT TERMINAL, WELDING	2	
31	0801840104	INSULATOR WASHER	2	
32	0801840004	INSULATOR WASHER	2	
33	0801841204	SET WASHER, OUTPUT TERMINAL	2	
34	0801884004	WING NUT	2	
35	0039512000	HEX. NUT	4	
36	0042212000	WASHER, LOCK	4	
37	0041412000	WASHER, FLAT	6	
38	D4268304704	NOISE FILTER	1	
39	D4237100203	COVER, OUTPUT TERMINAL	1	
39A	D4237400204	RUBBER SHEET	1	
40	0821800014	COLLAR	1	
41	D9311200004	STAY RUBBER	1	
42	0016906020	HEX. HEAD BOLT	2	

DLW-300ESA/ESA1 — CONTROL PANEL ASSY.

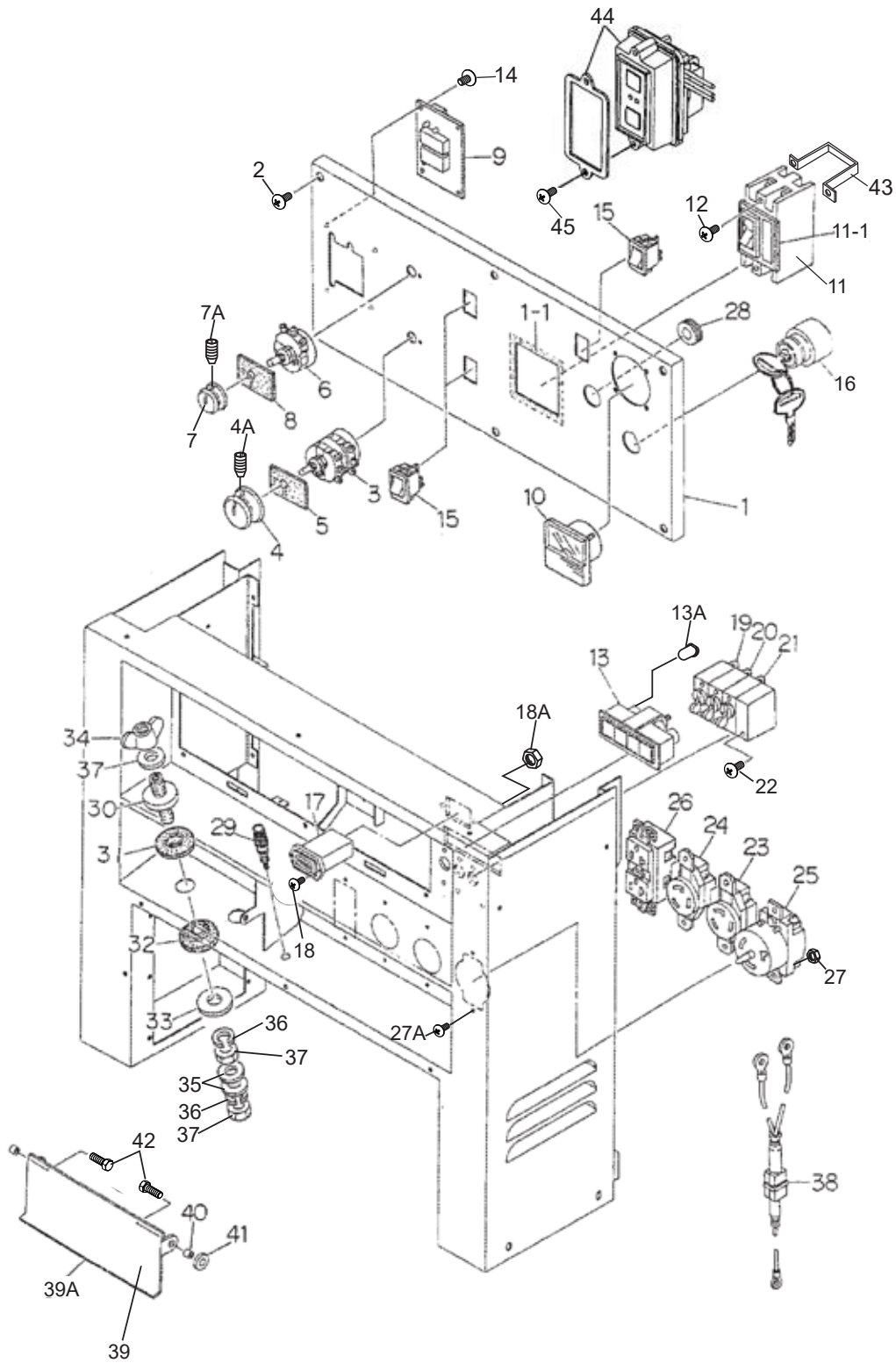

DLW-300ESA/ESA1 — CONTROL PANEL ASSY.

<u>NO.</u>	<u>PART NO.</u>	<u>PART NAME</u>	<u>QTY.</u>	<u>REMARKS</u>
1	D4224000903	CONTROL PANEL (DLW300ESA/ESA1).....	1.....	S/N 5647004 AND BELOW REPLACES P/N D4511302102
1	D4224000913	CONTROL PANEL (DLW300ESA/ESA1).....	1.....	S/N 5647005 ~ 5804074 REPLACES P/N D4511302112
1	D4224000923	CONTROL PANEL (DLW300ESA/ESA1).....	1.....	S/N 5804075 AND ABOVE REPLACES P/N D4511302122
1-1	D4491400004	RUBBER SEAL (DLW300ESA/ESA1)	1.....	S/N 5647004 AND BELOW
2	0021506030	MACHINE SCREW.....	6.....	REPLACES P/N 0021806030
3	0601840028	RHEOSTAT C/V REGULATOR, 500 OHM	1	
4	0601840103	KNOB.....	1.....	INCLUDES ITEMS W/#
4A#	0023304008	SET SCREW	2	
5	0801883003	INSULATOR	1	
6	0601840095	RHEOSTAT(ARC FORCE REG.) 2K OHM	1	
7	0601840170	KNOB.....	1.....	INCLUDES ITEMS W/%
7A%	0023303508	SET SCREW	2	
8	0801883003	INSULATOR	1	
9	D9924800194	DIGITAL MONITOR, DM-51A	1	
10	0601800281	AC VOLTMETER, 5A 0~150/300V	1	
11	0601806472	CIRCUIT BREAKER, 2P, 40A (DLW300ESA)....	1.....	S/N 5647004 AND BELOW
11	0601870451	CIRCUIT BREAKER, 2P, 40A (DLW300ESA)....	1.....	S/N 5647005 ~ 5804074
11	0601872304	CIRCUIT BREAKER, 2P, 40A (DLW300ESA)....	1.....	S/N 5804075 AND ABOVE
11	0601806472	CIRCUIT BREAKER, 2P, 40A (DLW300ESA1)..	1.....	S/N 5647004 AND BELOW
11	0601870451	CIRCUIT BREAKER, 2P, 40A (DLW300ESA1)..	1.....	S/N 5647005 ~ 5804074
11	0601872304	CIRCUIT BREAKER, 2P, 40A (DLW300ESA1)..	1.....	S/N 5804075 AND ABOVE
11-1	0317900080	RUBBER SEAL (DLW300ESA).....	2.....	S/N 5647004 AND BELOW
11-1	0317900080	RUBBER SEAL (DLW300ESA1).....	2.....	S/N 5647004 AND BELOW
12	Y0027204050	MACHINE SCREW (DLW300ESA).....	2.....	S/N 5647004 AND BELOW
12	0027104015	MACHINE SCREW (DLW300ESA).....	2.....	S/N 5647005 ~ 5804074
12	0027104015	MACHINE SCREW (DLW300ESA).....	4.....	S/N 5804075 AND ABOVE
12	Y0027204050	MACHINE SCREW (DLW300ESA1).....	2.....	S/N 5647004 AND BELOW
12	0027104015	MACHINE SCREW (DLW300ESA1).....	2.....	S/N 5647005 ~ 5804074
12	0027104015	MACHINE SCREW (DLW300ESA1).....	4.....	S/N 5804075 AND ABOVE
13	0601810523	INDICATOR ASSY.....	1.....	INCLUDES ITEMS W/\$
13A\$	0601810207	BULB.....	4.....	NLA
14	0027103006	MACHINE SCREW	4	
15	0601831600	ROCKER SWITCH	3	
16	1628663602	STARTER SWITCH	1.....	REPLACES P/N 3741059113
17	0601800682	HOUR METER, 32V	1.....	S/N 5898220 AND BELOW
17	Y0601800674	HOUR METER.....	1.....	S/N 5898221 AND ABOVE
18	Y0027403000	MACHINE SCREW	2	
18A	0207003000	HEX. NUT	2	
19	0601806423	CIRCUIT BREAKER, CB4, 1P, 20A.....	1.....	S/N 50005668 AND BELOW
19	0601873321	CIRCUIT BREAKER 1P, 20A.....	1.....	S/N 50005669 AND ABOVE
20	0601806424	CIRCUIT BREAKER, CB3, 1P, 30A.....	1.....	S/N 50005668 AND BELOW
20	0601873323	CIRCUIT BREAKER, 1P, 30A.....	1.....	S/N 50005669 AND ABOVE
21	0601806425	CIRCUIT BREAKER, CB2, 2P, 30A.....	1.....	S/N 50005668 AND BELOW
21	0601873324	CIRCUIT BREAKER, 2P, 30A.....	1.....	S/N 50005669 AND ABOVE

DLW-300ESA/ESA1 — CONTROL PANEL ASSY. (CONT'D.)

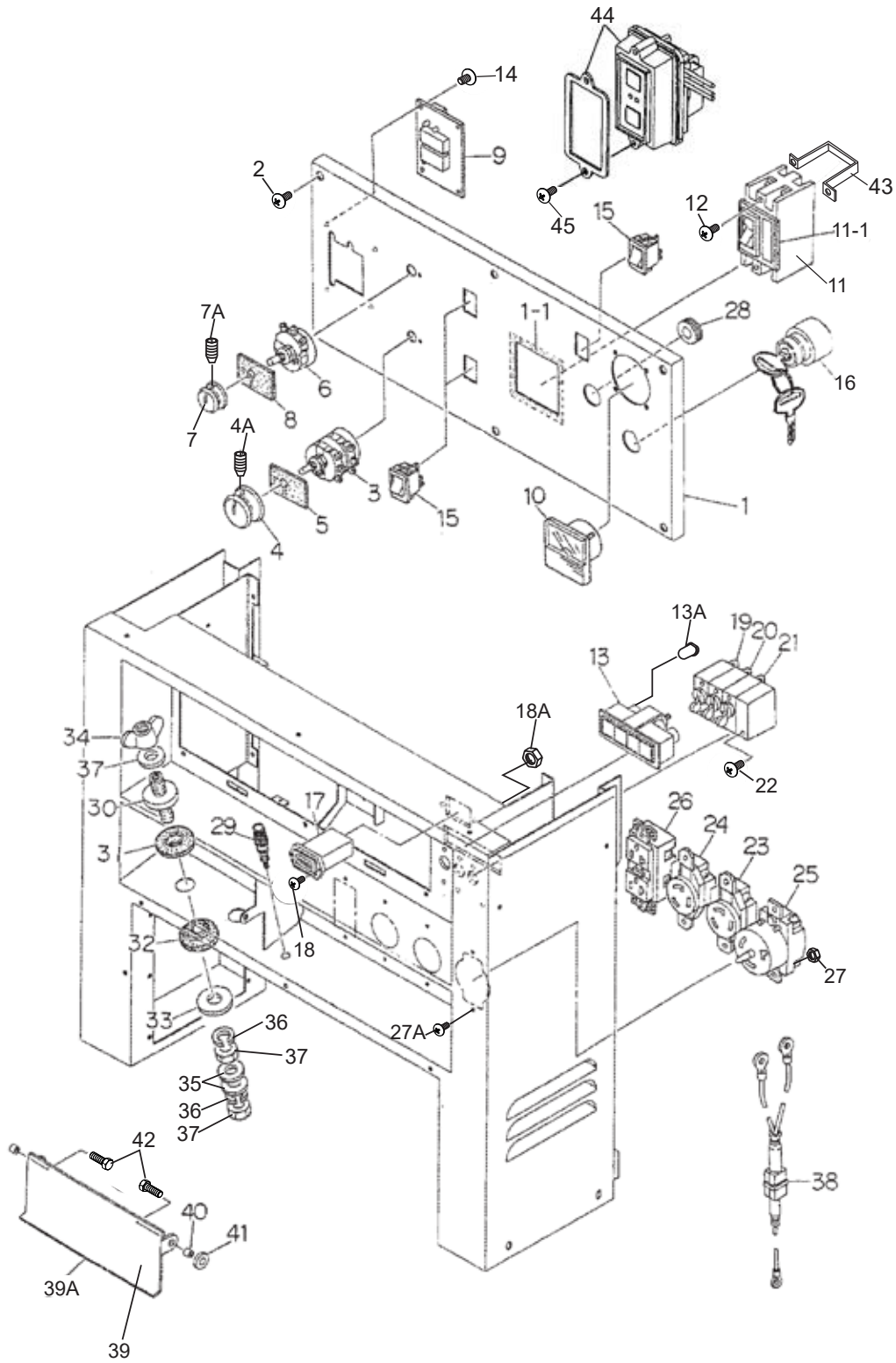

DLW-300ESA/ESA1 — CONTROL PANEL ASSY. (CONT'D.)

<u>NO.</u>	<u>PART NO.</u>	<u>PART NAME</u>	<u>QTY.</u>	<u>REMARKS</u>
22	Y0027303008	MACHINE SCREW	6	
23	0601811033	RECEPTACLE, L6-30R	1	
24	0601811031	RECEPTACLE, L5-30R	1	REPLACES P/N 0601811035
25	0601811034	RECEPTACLE, CS6369 (DLW300ESA).....	1	S/N 5655215 AND BELOW REPLACES P/N 0601812565
25	0601814014	RECEPTACLE, CS6369LM2 (DLW300ESA).....	1	S/N 5655216 AND ABOVE
25	0601811034	RECEPTACLE, CS6369 (DLW300ESA1).....	1	S/N 5655215 AND BELOW REPLACES P/N 0601812565
25	0601814014	RECEPTACLE, CS6369LM2 (DLW300ESA1)...	1	S/N 5655216 AND ABOVE
26	0601812598	RECEPT., 5-20R GF53OEM (DLW300ESA)	1	S/N 5610287 AND BELOW
26	Y0601814034	RECEPTACLE, GF20LA (DLW300ESA).....	1	S/N 5610288 ~ 5678512 REPLACES P/N 0601814013
26	0601814065	RECEPTACLE, 5-20R DR20 (DLW300ESA).....	1	S/N 5678513 AND ABOVE
26	0601814013	RECEPT., 5-20R GF20LA (DLW300ESA1)	1	S/N 5610288 ~ 5678512
26	0601814065	RECEPTACLE, 5-20R DR20 (DLW300ESA1)...	1	S/N 5678513 AND ABOVE
27	OEMAA8	HEX. NUT	8	REPLACES P/N 0207004000
27A	7538070	MACHINE SCREW	8	REPLACES P/N 0027104016
28	0601850290	GROMMET	1	
29	0601815109	GROUND TERMINAL	1	
30	0801888204	OUTPUT TERMINAL, WELDING	2	
31	0801840104	INSULATOR WASHER	2	
32	0801840004	INSULATOR WASHER	2	
33	0801841204	SET WASHER, OUTPUT TERMINAL	2	
34	0801884004	WING NUT	2	
35	0039512000	HEX. NUT	4	
36	0042212000	WASHER, LOCK	4	
37	0041412000	WASHER, FLAT	6	
38	D4268304704	NOISE FILTER.....	1	S/N 5804074 AND BELOW
38	D4268304714	NOISE FILTER.....	1	S/N 5804075 AND ABOVE
39	D4237100203	COVER, OUTPUT TERMINAL	1	
39A	D4237400204	RUBBER SHEET	1	
40	0821800014	COLLAR	2	
41	D9311200004	STAY RUBBER	1	
42	011206020	HEX. HEAD BOLT.....	2	REPLACES P/N 0016906020
43	D9121000604	BRACKET, CIRCUIT BREAKER (DLW300ESA)...	1	S/N 5647005 ~ 5655215
43	A9121000304	BRACKET, CIRCUIT BREAKER (DLW300ESA)...	1	S/N 5655216 ~ 5804074
43	D9121000604	BRACKET, CIRCUIT BREAKER (DLW300ESA1)...	1	S/N 5647005 ~ 5655215
43	D9121000304	BRACKET, CIRCUIT BREAKER (DLW300ESA1)...	1	S/N 5655216 ~ 5804074
44	0601829301	GFCI SENSING MODULE, GF5M120A, 120V..	1	DLW300ESA S/N 5804075 AND ABOVE
44	0601829301	GFCI SENSING MODULE, GF5M120A, 120V..	1	DLW300ESA1 S/N 5804075 ~ 5914263
44	0601829302	GFCI SENSING MODULE, PGFM-11-B-A1	1	DLW300ESA1 S/N 5914264 ~ 50018326
44	0601829301	GFCI SENSING MODULE, GF5M120A, 120V..	1	DLW300ESA1 S/N 50018327 AND ABOVE
45	0027104015	MACHINE SCREW	2	S/N 5804075 AND ABOVE

DLW-300ES — ELECTRIC PARTS 1 ASSY.

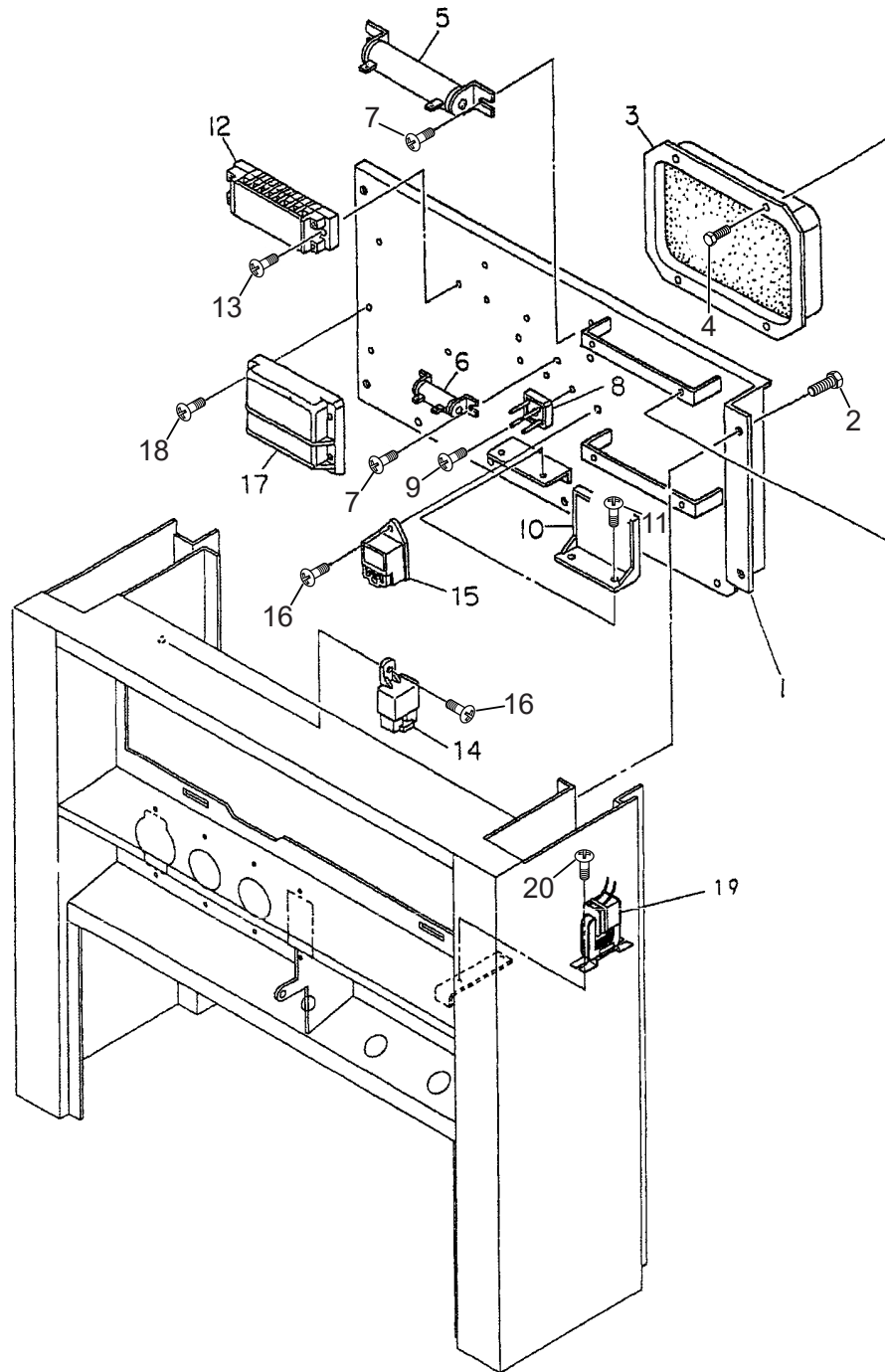

DLW-300ES — ELECTRIC PARTS 1 ASSY.

<u>NO.</u>	<u>PART NO.</u>	<u>PART NAME</u>	<u>QTY.</u>	<u>REMARKS</u>
1	D4224200003	SET PANEL, ELECTRIC PARTS	1	
2	0016906016	HEX. HEAD BOLT	4	
3	0601820664	AUTOMATIC VOLTAGE REGULATOR	1	
4	0016905016	HEX. HEAD BOLT	4	
5	0601842437	RESISTOR, 100W 150Ω	2	
6	0601842349	RESISTOR, 20W 35Ω	1	
7	0027104016	MACHINE SCREW	6	
8	0601823204	RECTIFIER, S5VB60	3	
9	0027203016	MACHINE SCREW	3	
10	D9925800064	IDLE CONTROL UNIT	1	
11	0027105016	MACHINE SCREW	2	
12	0601815992	TERMINAL BOARD	1	
13	0027104025	MACHINE SCREW	2	
14	0601824527	RELAY, DC12V	1	
15	1569465990	LAMP TIMER	1	REPLACES P/N 1569465992
16	0027105016	MACHINE SCREW	2	
17	1747260605	EMERGENCY UNIT.....	1	REPLACES P/N 0602200475
18	0027105020	MACHINE SCREW	4	
19	0601804211	CURRENT TRANSFORMER	1	
20	0027104010	MACHINE SCREW»	2	

DLW-300ES — ELECTRIC PARTS 2 ASSY.

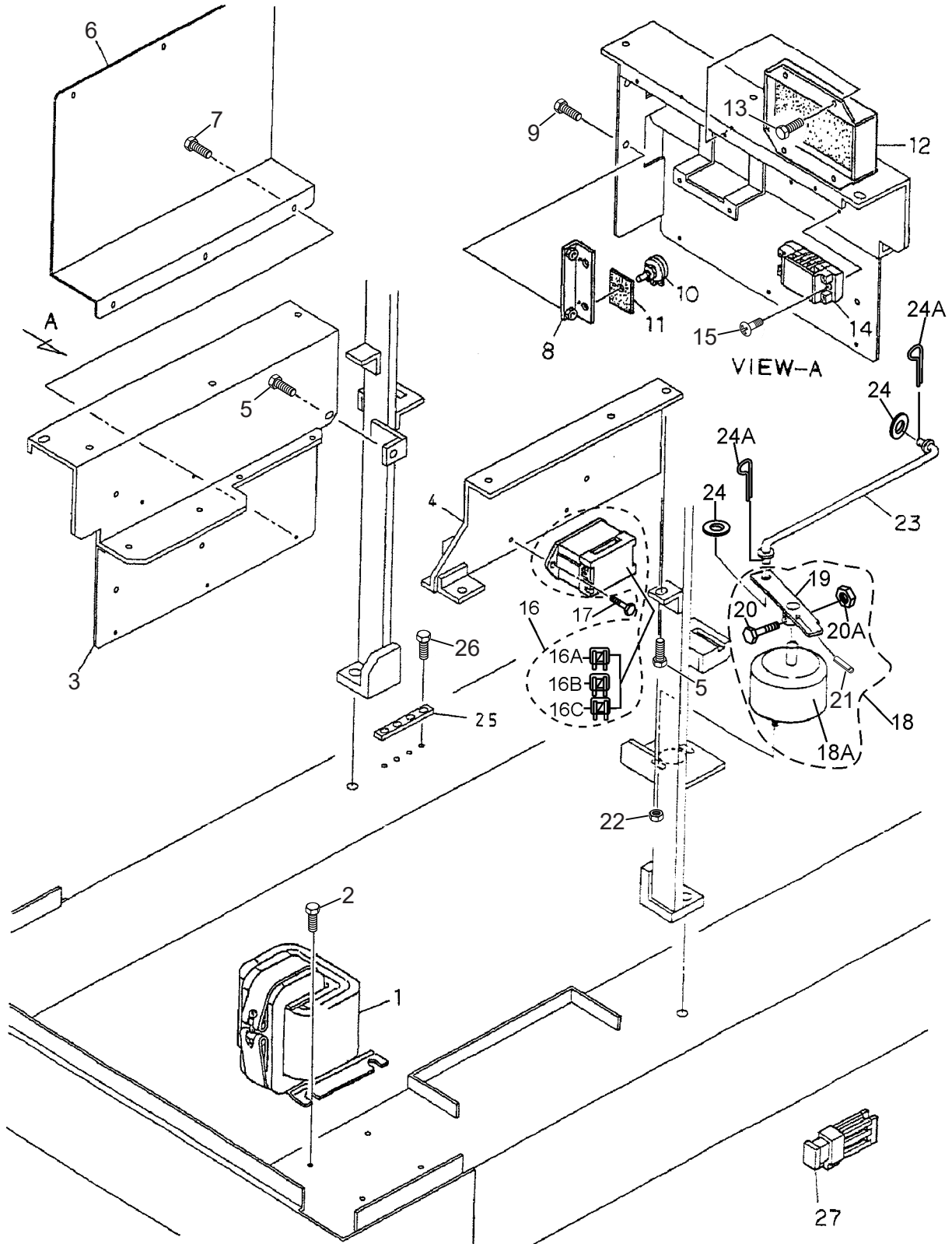

DLW-300ES — ELECTRIC PARTS 2 ASSY.

<u>NO.</u>	<u>PART NO.</u>	<u>PART NAME</u>	<u>QTY.</u>	<u>REMARKS</u>
1	D4264500503	DC REACTOR	1	
2	0016906016	HEX.HEAD BOLT	4	
3	D4434000503	SUPPORT, FUEL TANK	1	
4	D4434000304	SUPPORT, FUEL TANK	1	
5	0016908020	HEX. HEAD BOLT	5	
6	D4261700204	BRACKET	1	
7	0016904016	HEX. HEAD BOLT	2	
8	D4262602004	VR SET PLATE	1	
9	0016906016	HEX. HEAD BOLT	2	
10	0601840211	RHEOSTAT, 10KΩ	1	
11	0601883003	INSULATOR	1	
12	D9924800024	IGBT CONTROL UNIT	1	
13	0016905016	HEX. HEAD BOLT	4	
14	0601815731	TERMINAL BOARD	1	
15	0027104020	MACHINE SCREW	2	
16	8701899004	FUSE BOX.....	1	INCLUDES ITEMS W/#
16A#	0601806642	FUSE, 5A	4	
16B#	0601806643	FUSE, 15A	2	
16C#	0601806644	FUSE, 30A	2	
17	0016905016	HEX. HEAD BOLT	2	
18	8702636004	ROTARY SOLENOID ASSY.....	1	INCLUDES ITEMS W/+
18A+	1620150404	ROTARY SOLENOID	1	
19+	8702631004	ARM, SOLENOID	1	
20+	0010106020	HEX. HEAD BOLT	1	
20A+	0030006000	HEX. NUT	1	
21+	0050403020	SPRING PIN	1	
22	0207006000	HEX. NUT	2	
23	D4355300004	GOVERNOR ROD	1	
24	0041208000	WASHER, FLAT	2	
24A	0041208000	SNAP PIN	2	
25	B1262800004	PLATE	1	
26	0019206020	HEX. HEAD BOLT	4	
27	0601806640	FUSE, 65A	1	

DLW-300ES — ELECTRIC PARTS 3 ASSY.

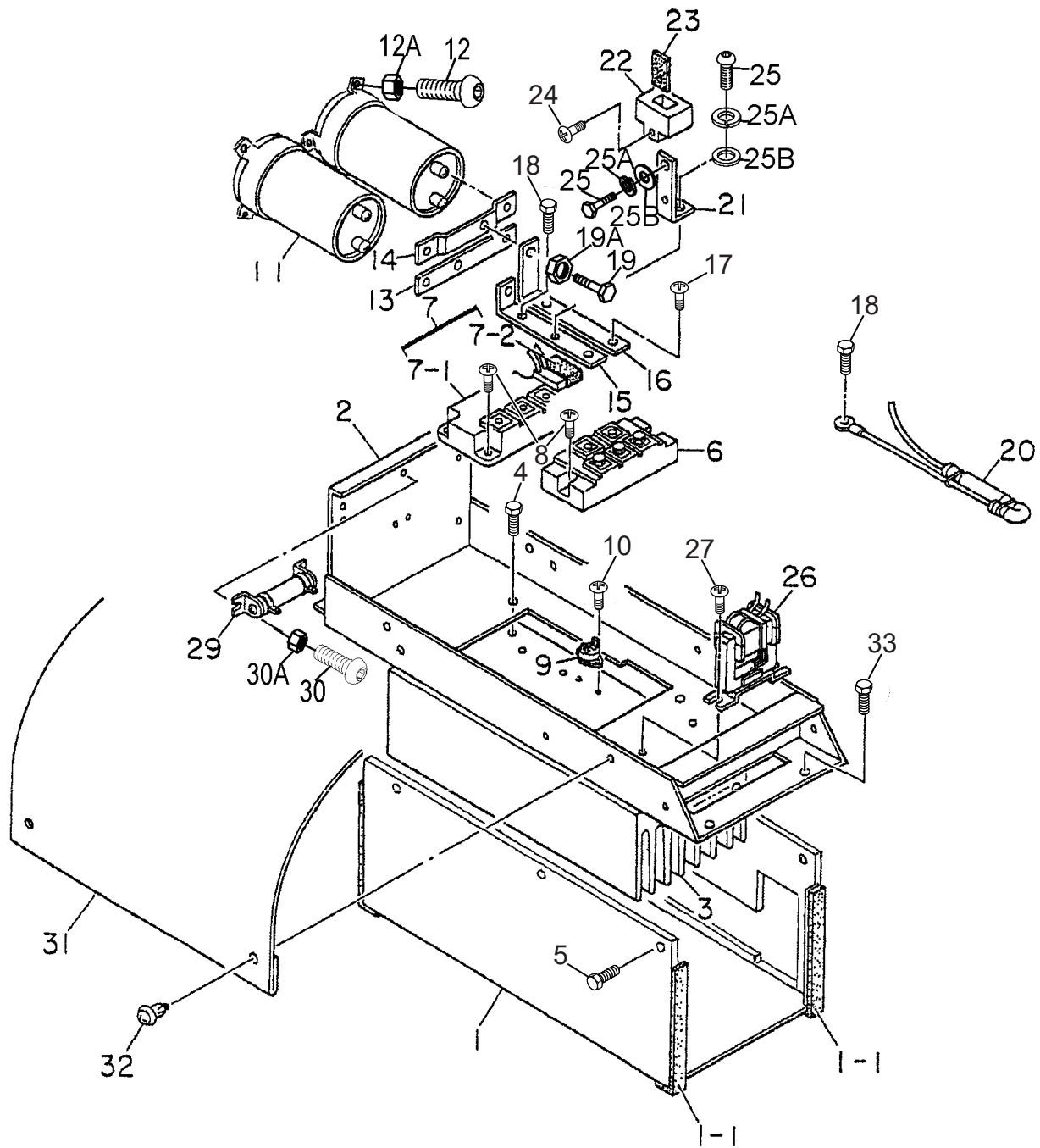

DLW-300ES — ELECTRIC PARTS 3 ASSY.

<u>NO.</u>	<u>PART NO.</u>	<u>PART NAME</u>	<u>QTY.</u>	<u>REMARKS</u>
1	D4214100003	COVER, COOLING FIN	1	
1-1	0315500140	RUBBER SEAL	4	
2	D4214000103	BRACKET, COOLING FIN	1	
3	D4268304403	COOLING FIN	1	
4	0016906016	HEX.HEAD BOLT	1	
5	0016906016	HEX.HEAD BOLT	4	
6	0601823256	RECTIFIER	1	
7	D42468000403	IGBT MODULE ASSY.	1	INCLUDES ITEMS W/#
7-1#	0601821258	IGBT MODULE	1	
7-2#	D9925800044	PROTECTIVE UNIT	1	
8	0027105016	MACHINE SCREW	6	
9	0601831053	THERMAL SWITCH	1	
10	0021003010	MACHINE SCREW	2	
11	0601826188	CAPACITOR	2	
12	0027104010	MACHINE SCREW	6	
12A	0207204000	HEX. NUT	6	
13	D4267301304	PLATE	1	
14	D4267301204	PLATE	1	
15	D4268304104	PLATE	1	
16	D4267301404	PLATE	1	
17	0027105016	MACHINE SCREW	2	
18	0017806014	HEX.HEAD BOLT	2	
19	0017106020	HEX.HEAD BOLT	2	
19A	0207206000	HEX. NUT	2	
20	D4268600204	RESISTOR ASSY., 510K Ω	1	
21	D4268304604	PLATE	1	
22	0601804244	DC CURRENT TRANSFORMER	1	
23	D4235400004	INSULATOR	1	
24	0027104020	MACHINE SCREW	1	
25	0019008016	HEX.HEAD BOLT	2	
25A	0040008000	WASHER, LOCK	2	
25B	0042708000	WASHER, FLAT	2	
26	0601804211	CURRENT TRANSFORMER	1	
27	0027104010	MACHINE SCREW	2	
29	0601842262	RESISTOR, 20W 1K Ω	1	
30	0027104010	MACHINE SCREW	2	
30A	0207204000	HEX. NUT	2	
31	D4215600204	COVER, ELECTRIC PARTS	1	
32	0605011411	SET SCREW	4	
33	0016906016	HEX. HEAD BOLT	4	

DLW-300ESA/ESA1 — ELECTRIC PARTS 1 ASSY.

<u>NO.</u>	<u>PART NO.</u>	<u>PART NAME</u>	<u>QTY.</u>	<u>REMARKS</u>
1	D4261500603	SET PANEL, ELECTRIC PARTS	1	
2	0016906015	HEX. HEAD BOLT	4	
3	0601820664	AUTOMATIC VOLTAGE REGULATOR, 5W	1	INCLUDES ITEMS W/%
3A%	0601806681	FUSE, 5A	1	
4	0016905015	HEX. HEAD BOLT	4	
5	0601820037	RECTIFIER	1	
6	0601842349	RESISTOR, 20W 35Ω	2	
7	7538070	MACHINE SCREW	6	REPLACES P/N 0027104016
8	0601823204	RECTIFIER	1	
9	0027203016	MACHINE SCREW	2	
10	0601823857	IDLE CONTROL UNIT	1	
11	0027105016	MACHINE SCREW	2	
12	0601815422	TERMINAL BOARD	1	
13	0027104020	MACHINE SCREW	2	
15	1569465992	LAMP TIMER	1	REPLACES P/N 0602201273
16	0027105016	MACHINE SCREW	2	
17	1747260606	EMERGENCY UNIT	1	REPLACES P/N 1747260605
18	0027105020	MACHINE SCREW	4	
19	0601804211	CURRENT TRANSFORMER	1	
20	0027104010	MACHINE SCREW	2	
21	D4261600704	BRACKET, COOLING FIN	2	
22	D4268303103	COOLING FIN	2	
23	0016906015	HEX.HEAD BOLT	8	
24	0601823228	RECTIFIER	2	S/N 5906625 AND BELOW
24	0601823239	RECTIFIER	2	S/N 5906626 AND ABOVE
25	D4268000303	IGBT MODULE ASSY.	2	INCLUDES ITEMS W/#
25-1#	D4268000303	IGBT MODULE	2	REPLACES P/N 0601821259
25-2#	D9925800044	PROTECTIVE UNIT	2	
26	0027105016	MACHINE SCREW	12	
27	0601831053	THERMAL SWITCH	2	
28	0021003010	MACHINE SCREW	4	
29	0601826188	CAPACITOR	2	
30	0027104010	MACHINE SCREW	6	
31	D4262800704	INSULATOR RUBBER	2	
32	D4268304004	PLATE	2	
33	D4268303904	PLATE	2	
34	Y0017805012	HEX. HEAD BOLT	10	
35	Y0017806012	HEX. HEAD BOLT	4	
36	D4268301704	PLATE	2	
37	0601804202	DC CURRENT TRANSFORMER	2	
37A	D4247704204	CORD	2	
38	D4235400004	INSULATOR	2	
39	0027104020	MACHINE SCREW	2	

DLW-300ESA/ESA1 — ELECTRIC PARTS 1 ASSY. (CONT'D.)

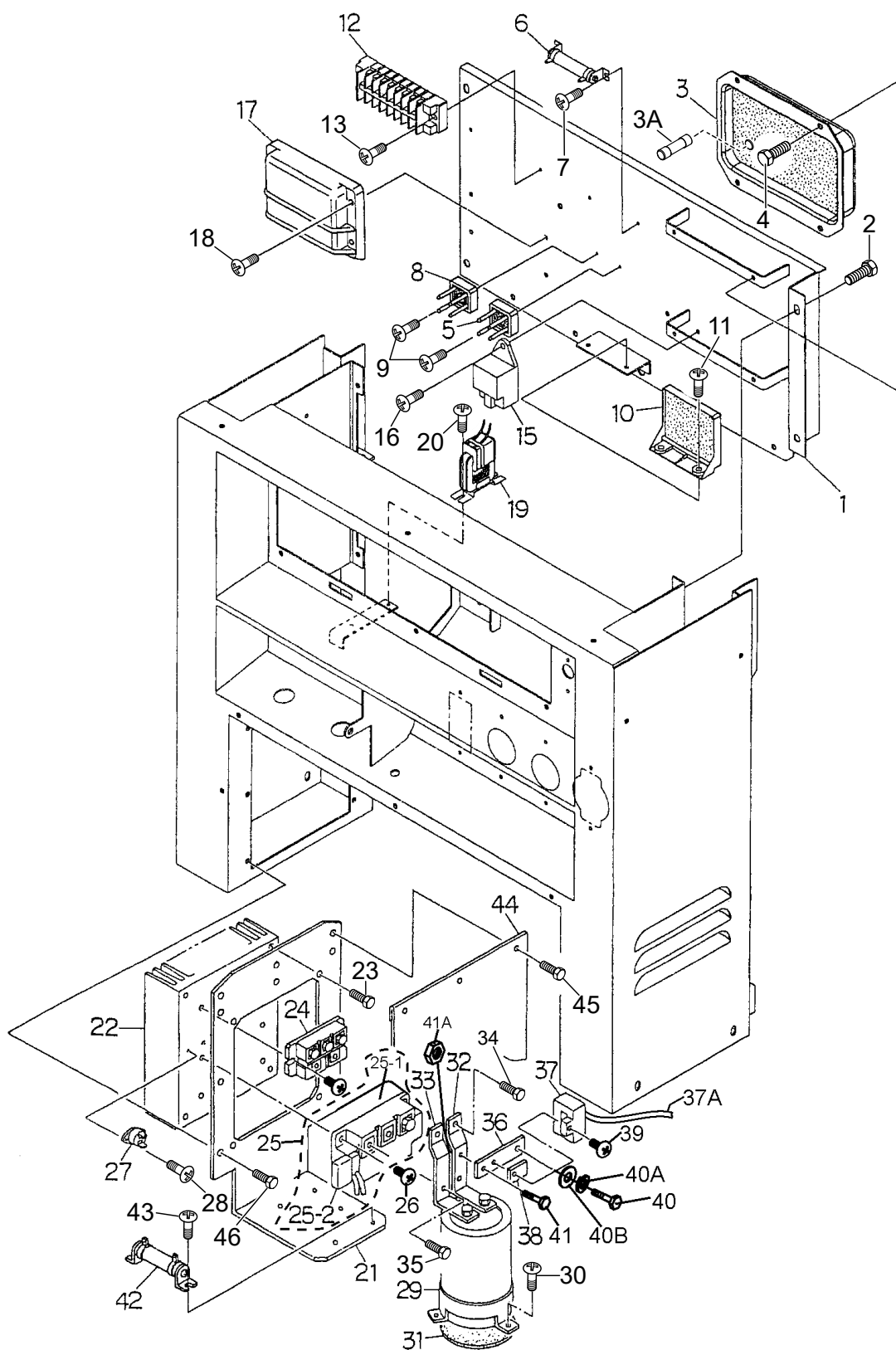

DLW-300ESA/ESA1 — ELECTRIC PARTS 1 ASSY. (CONT'D.)

<u>NO.</u>	<u>PART NO.</u>	<u>PART NAME</u>	<u>QTY.</u>	<u>REMARKS</u>
40	Y0019006010	HEX.HEAD BOLT	2	
40A	0040006000	WASHER, LOCK	2	
40B	Y0042706000	WASHER, FLAT	2	
41	011206020	HEX. HEAD BOLT.....	2.....	REPLACES P/N 0016906020
41A	0176060030	HEX. HEAD NUT	2.....	REPLACES P/N 0207006000
42	0601842467	RESISTOR, 20W 2kΩ	2	
43	0027104010	MACHINE SCREW	4	
44	D4262700304	COVER, ELECTRIC PARTS	2	
45	0605011411	SET SCREW	8	
46	0016906015	HEX.HEAD BOLT	14	

DLW-300ESA/ESA1 — ELECTRIC PARTS 2 ASSY.

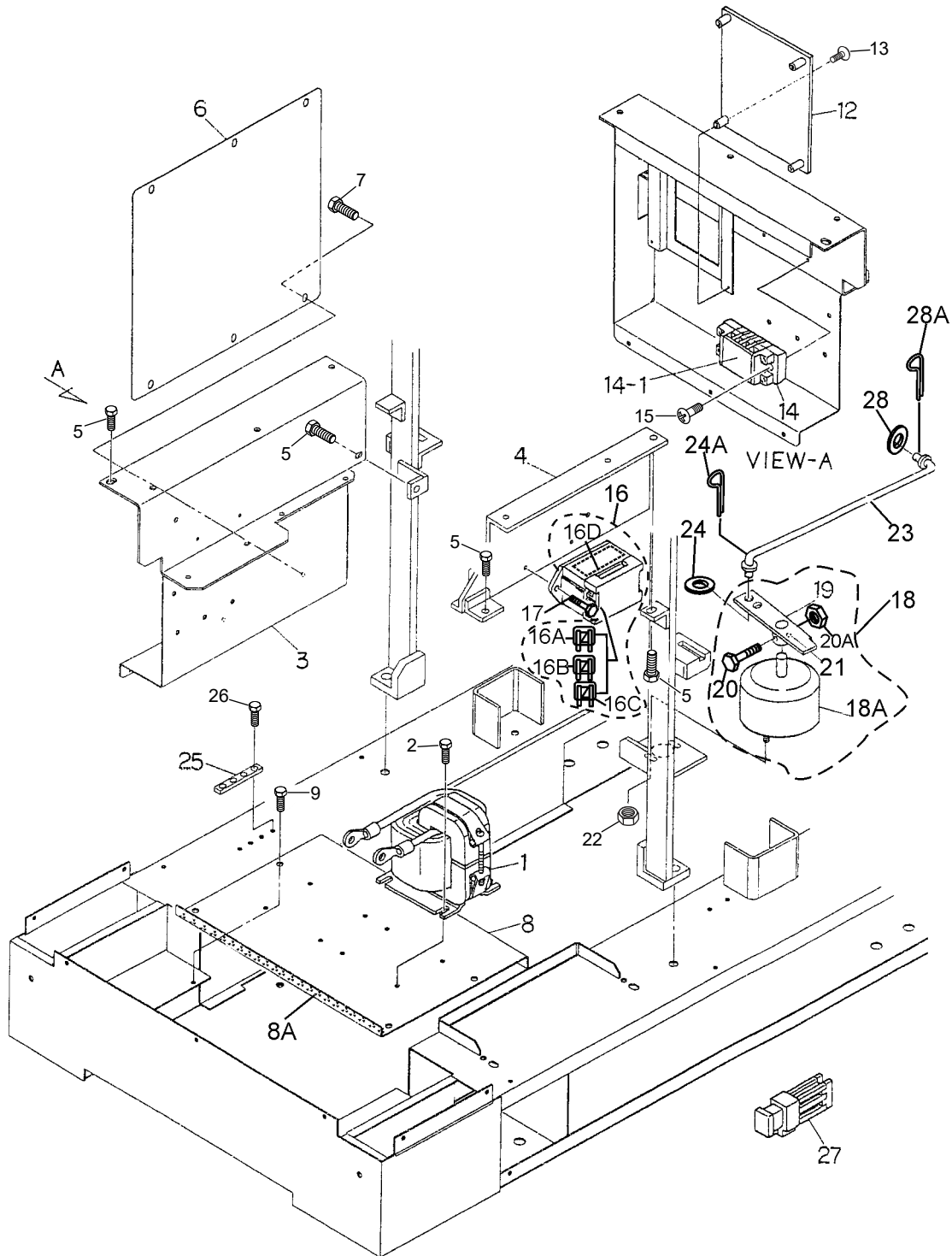

DLW-300ESA/ESA1 — ELECTRIC PARTS 2 ASSY.

<u>NO.</u>	<u>PART NO.</u>	<u>PART NAME</u>	<u>QTY.</u>	<u>REMARKS</u>
1	D5264500103	DC REACTOR	2	
2	0016906015	HEX.HEAD BOLT	8	
3	D4434000903	SUPPORT, FUEL TANK (DLW-300ESA/ESA1)	1	S/N 5655215 AND BELOW
3	D4434000913	SUPPORT, FUEL TANK (DLW-300ESA/ESA1)	1	S/N 5655216 AND ABOVE
4	D4434000804	SUPPORT, FUEL TANK	1	
5	011008020	HEX. HEAD BOLT	4	REPLACES P/N 0016908020
6	D4261700404	COVER (DLW-300ESA/ESA1)	1	S/N 5655215 AND BELOW
6	D4261700414	COVER (DLW-300ESA/ESA1)	1	S/N 5655216 AND ABOVE
7	0016906015	HEX. HEAD BOLT	6	
8	D4261600804	BRACKET, REACTOR	1	
8A	D4497600004	LINING	1	
9	0016906015	HEX. HEAD BOLT	4	
12	D9924800204	IGBT CONTROL UNIT, IC CV-12	1	
13	Y0207103025	MACHINE SCREW	4	
14	0601815731	TERMINAL BOARD, KT30 4P	1	
14-1	A9522000104	DECAL: TERMINAL BOARD	1	
15	0027104020	MACHINE SCREW	2	
16	B0352500104	FUSE BOX	1	INCLUDES ITEMS W/#
16A#	0601806642	FUSE, 5A	4	
16B#	0601806643	FUSE, 15A	2	
16C#	0601806644	FUSE, 30A	2	
16D#	8700625504	DECAL, FUEL BOX	1	S-4936
17	Y0016905015	HEX. HEAD BOLT	2	
18	8702636004	ROTARY SOLENOID ASSY.	1	INCLUDES ITEMS W/+
18A+	1622636103Z	ROTARY SOLENOID	1	REPLACES P/N 1620150404
19+	8702631004	ARM, SOLENOID	1	
20+	0010106020	HEX. HEAD BOLT	1	
20A+	020106050	HEX. NUT	1	REPLACES P/N 0030006000
21+	0050403020	SPRING PIN	1	
22	0176060030	HEX. NUT	2	REPLACES P/N 0207006000
23	D4355300004	GOVERNOR ROD	1	
24	0401450080	WASHER, FLAT	1	REPLACES P/N 0041208000
24A	0605010503	SNAP PIN	1	
25	B1262800004A	PLATE	1	REPLACES P/N B1262800004
26	011206020	HEX. HEAD BOLT	4	REPLACES P/N 0019206020
27	0601806640	FUSE, 65A	1	
28	952404470	WASHER, FLAT	1	REPLACES P/N 0041206000
28A	505015300	SNAP PIN	1	REPLACES P/N 0605010502

ENGINE AND RADIATOR ASSY.

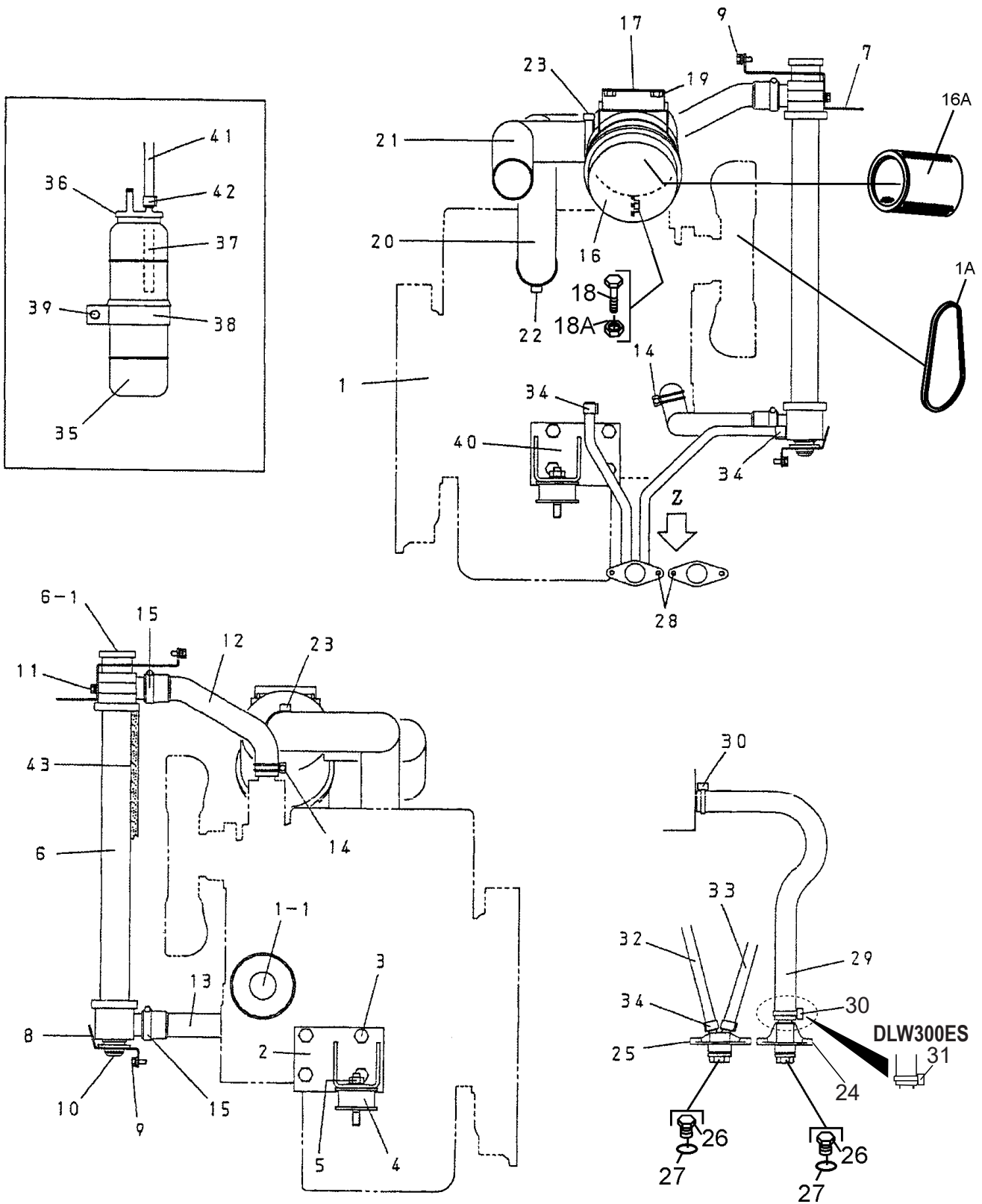

ENGINE AND RADIATOR ASSY.

<u>NO.</u>	<u>PART NO.</u>	<u>PART NAME</u>	<u>QTY.</u>	<u>REMARKS</u>
1	D4924200014	ENGINE, KUBOTA D722-E2B (DLW-300ES)	1	INCLUDES ITEMS W/#
1	D4924200064	ENGINE, KUBOTA D722-E3B (DLW-300ESA/ESA1)	1	INCLUDES ITEMS W/# S/N 5697713 AND BELOW
1	D4924200064	ENGINE, KUBOTA D722-E4B (DLW-300ESA/ESA1)	1	INCLUDES ITEMS W/# S/N 5697714 AND ABOVE
1A#	1747297010	FAN BELT	1	REPLACES P/N 1747297011
1-1#	23725-23	CARTRIDGE, OIL FILTER	1	REPLACES P/N 1585399171
2	D4304200304	ENGINE FOOT	1	
3	012210020	HEX. HEAD BOLT	8	REPLACES P/N 0010710020
4	0605000066	RUBBER SUSPENSION	2	
5	021112140	HEX. NUT	2	REPLACES P/N 0207010000
6	0602012779	RADIATOR	1	INCLUDES ITEMS W/%
6-1%	0602011064	CAP, RADIATOR (DLW-300ES)	1	REPLACES P/N 0225101990
6-1%	Y0602015700	CAP, RADIATOR (DLW-300ESA/ESA1)	1	REPLACES P/N Y0602011079
7	D4311100104	BRACKET, RADIATOR	1	
8	D4312100813	BRACKET, RADIATOR	1	
9	0016906016	HEX. HEAD BOLT (DLW-300ES)	5	
9	0016906015	HEX. HEAD BOLT (DLW-300ESA/ESA1)	5	
10	B1312600004	RUBBER MOUNT	2	
11	011206020	HEX. HEAD BOLT (DLW-300ES)	2	REPLACES P/N 0016906020
11	0016906015	HEX. HEAD BOLT (DLW-300ESA/ESA1)	2	
12	D4311500003	RADIATOR HOSE	1	
13	D4311500103	RADIATOR HOSE	1	
14	0605515110	HOSE BAND, ø34 (DLW-300ES)	1	
14	0605515110	HOSE BAND, ø34 (DLW-300ESA/ESA1)	2	S/N 5844492 AND BELOW
14	0605515003	HOSE BAND, ø30 (DLW-300ESA/ESA1)	2	S/N 5844493 AND ABOVE
15	0605515134	HOSE BAND	2	
16	0602046266	AIR CLEANER	1	INCLUDES ITEMS W/\$
16A\$	0602046391	ELEMENT, AIR CLEANER	1	
17	D4374200203	BRACKET, AIR CLEANER, (DLW-300ES)	1	
17	W8712031503	BRACKET, AIR CLEANER (DLW-300ESA/ESA1)	1	
18	011208025	HEX. HEAD BOLT	1	REPLACES P/N 0016908025
18A	0207008000	HEX. NUT (DLW-300ES)	1	
19	0016906016	HEX. HEAD BOLT (DLW-300ES)	2	
19	011008020	HEX. HEAD BOLT (DLW-300ESA/ESA1)	2	REPLACES P/N 0016908020
20	7812036404	HOSE, AIR CLEANER (DLW-300ES)	1	
20	8702037003	HOSE, AIR CLEANER (DLW-300ESA/ESA1)	1	
21	8702037003	HOSE, AIR CLEANER (DLW-300ES)	1	
21	7812036404	HOSE, AIR CLEANER (DLW-300ESA/ESA1)	1	
22	0605515006	HOSE BAND, ø50	1	
23	0602014302	HOSE BAND, ø56	2	REPLACES P/N 0605515021
24	1502025103C	DRAIN JOINT, OIL	1	REPLACES P/N 1502025103
25	1622014103	DRAIN JOINT, WATER	1	
26	0802011104	PLUG	2	
27	0150000018	O-RING, P-18	2	

ENGINE AND RADIATOR ASSY (CONT'D.)

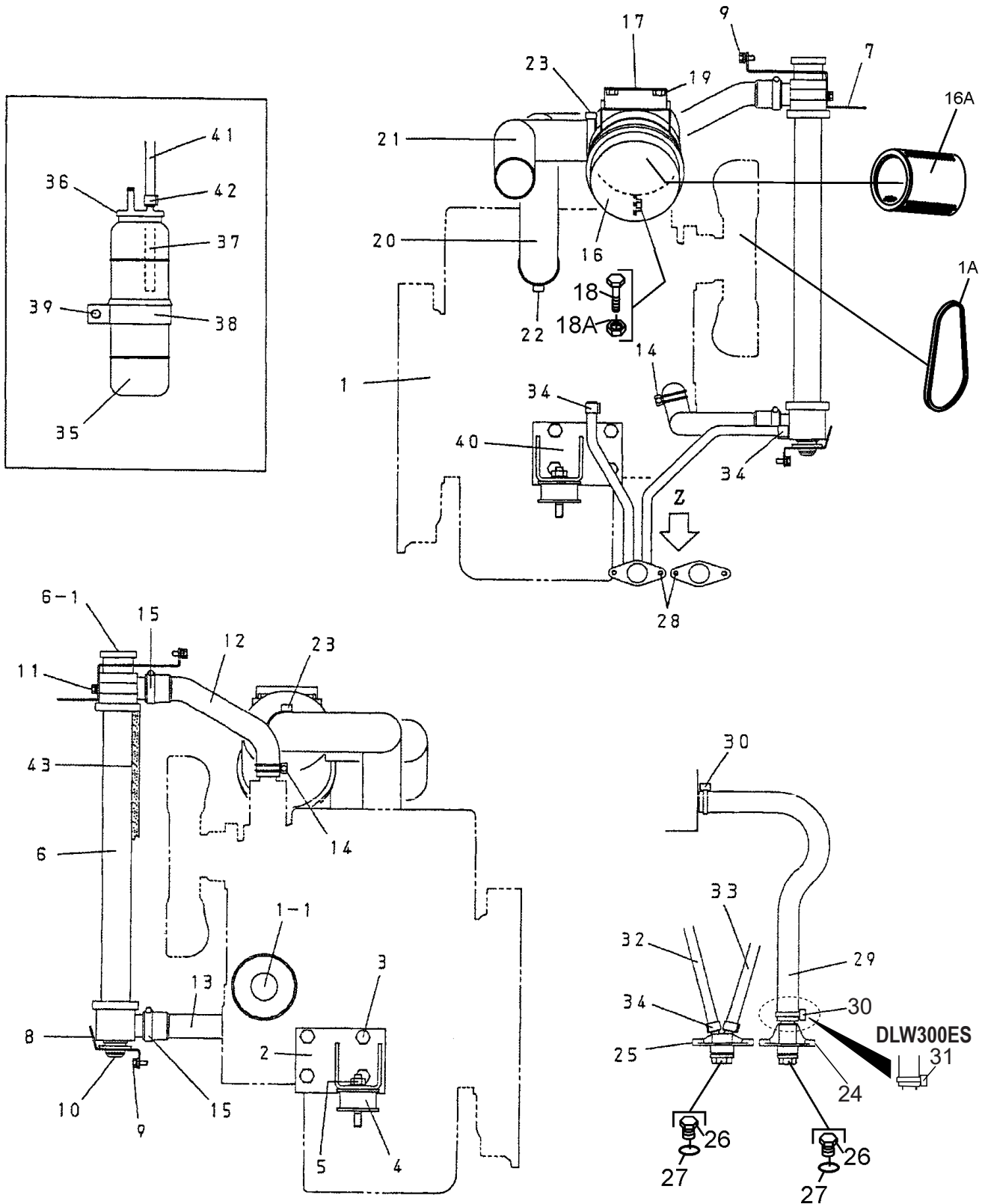

ENGINE AND RADIATOR ASSY (CONT'D.)

<u>NO.</u>	<u>PART NO.</u>	<u>PART NAME</u>	<u>QTY.</u>	<u>REMARKS</u>
28	0016906020	HEX.HEAD BOLT (DLW-300ES)	4	
28	0016906015	HEX.HEAD BOLT (DLW-300ESA/ESA1)	4	
29	D4321100003	DRAIN HOSE	1	
30	0605515073	HOSE BAND (DLW-300ES)	1	
30	0605515198	HOSE BAND (DLW-300ES/ESA).....	2.....	REPLACES P/N 0605515064
31	0605515198	HOSE BAND (DLW-300ES)	1	
32	0199900390	DRAIN HOSE	1	
33	0199900660	DRAIN HOSE	1	
34	0605515094	HOSE BAND, ø12	4	
35	0802081403	RESERVE TANK	1	
36	0802081104	CAP, RESERVE TANK	1	
37	0199100215	HOSE	1	
38	6262082304	BRACKET, RESERVE TANK	1	
39	0016906025	HEX. HEAD BOLT, (DLW300ES)	1	
39	0016906015	HEX. HEAD BOLT, (DLW300ESA/ESA1)	1	
40	D4304200204	ENGINE FOOT	1	
41	0199900500	HOSE	1	
42	0605515094	HOSE BAND, ø12	2	
43	0220300375	RUBBER SEAL	2	

BATTERY ASSY.

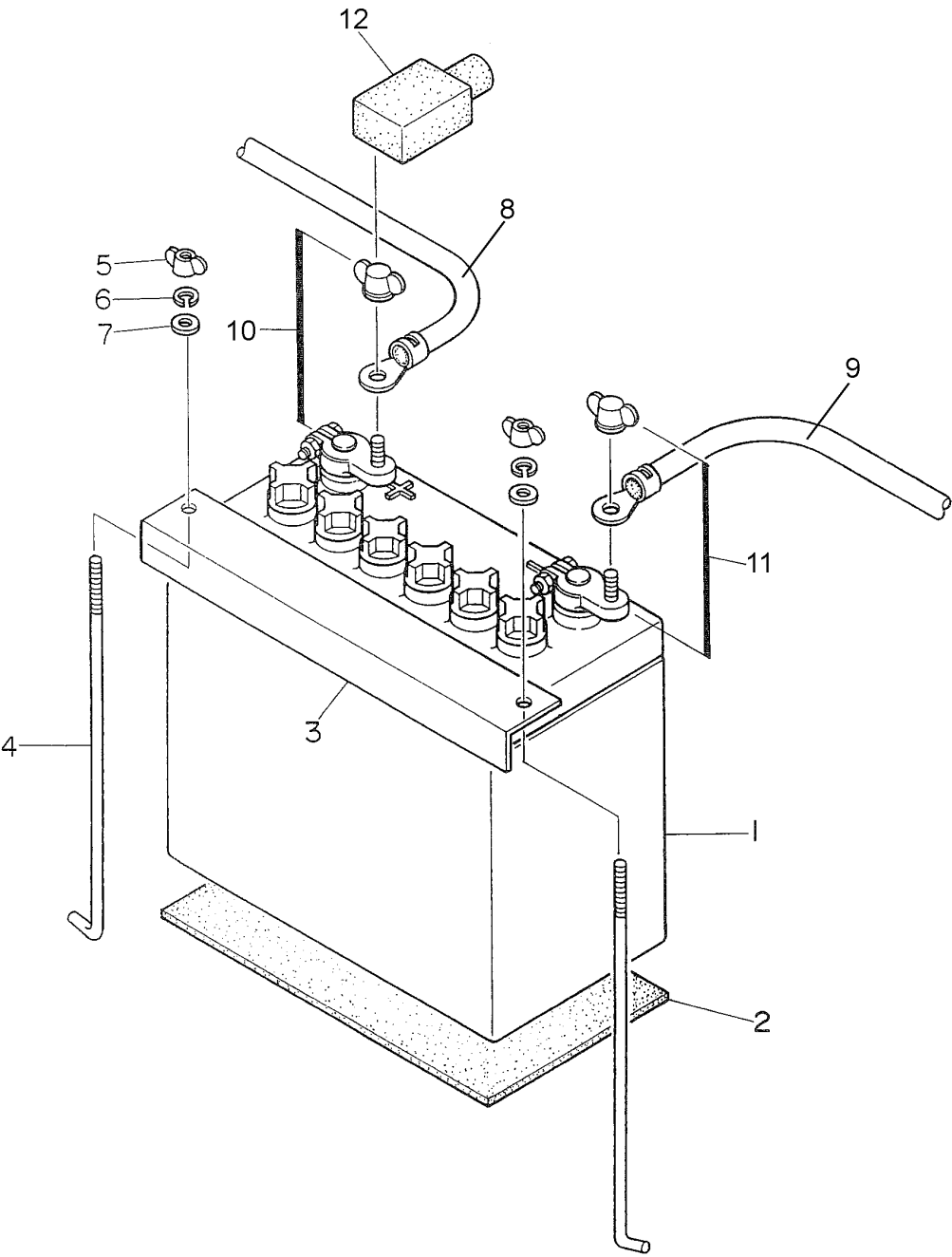

BATTERY ASSY.

<u>NO.</u>	<u>PART NO.</u>	<u>PART NAME</u>	<u>QTY.</u>	<u>REMARKS</u>
1	0169105524	BATTERY, 55B24L.....	1.....	REPLACES P/N 0166105524
2	8722251004	BATTERY SHEET	1	
3	7552253004	BATTERY BAND	1	
4	7872251004	BATTERY BOLT	2	
5	0037806000	WING NUT	2	
6	0040006000	WASHER, LOCK	2	
7	952404470	WASHER, FLAT.....	2.....	REPLACES P/N 0041606000
8		BATTERY CABLE.....	1.....	PURCHASE LOCALLY
9		BATTERY CABLE.....	1.....	PURCHASE LOCALLY
10	0602220312	TERMINAL ASSY.....	1.....	NO. 15L (+)
11	0602220313	TERMINAL ASSY.....	1.....	NO. 15L (-)
12	0845040414	TERMINAL CAP.....	1.....	REPLACES P/N 0602220600

MUFFLER ASSY.

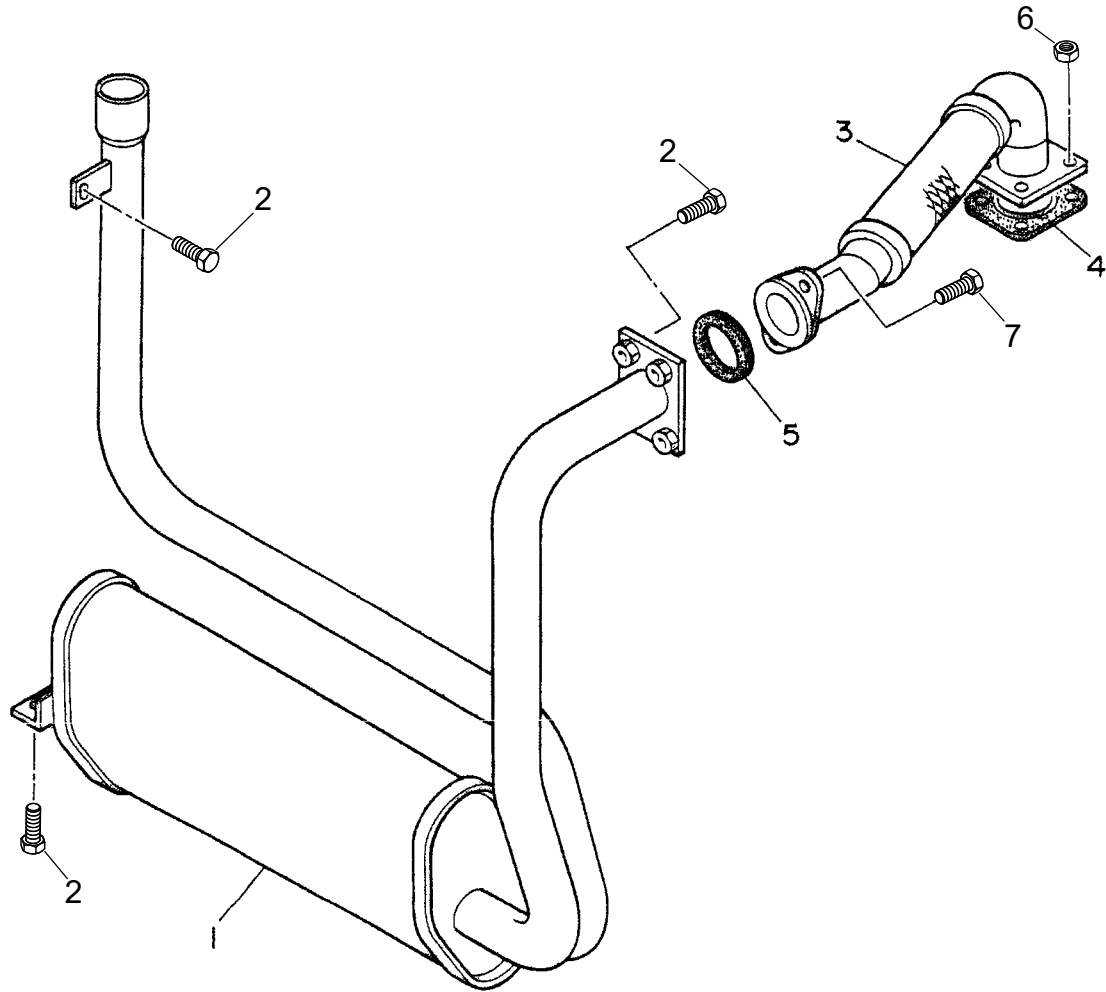

MUFFLER ASSY.

<u>NO.</u>	<u>PART NO.</u>	<u>PART NAME</u>	<u>QTY.</u>	<u>REMARKS</u>
1	D4331000003	MUFFLER	1	
2	011008020	HEX. HEAD BOLT.....	5.....	REPLACES P/N 0016908020
3	D4334000003	EXHAUST PIPE	1	
4	1526312370	GASKET	1.....	REPLACES P/N 1526312371
5	D9304000004	GASKET	1	
6	020108060	HEX. NUT	4.....	REPLACES P/N 0207008000
7	011208030	HEX. HEAD BOLT.....	2.....	REPLACES P/N 0016908030

FUEL TANK ASSY.

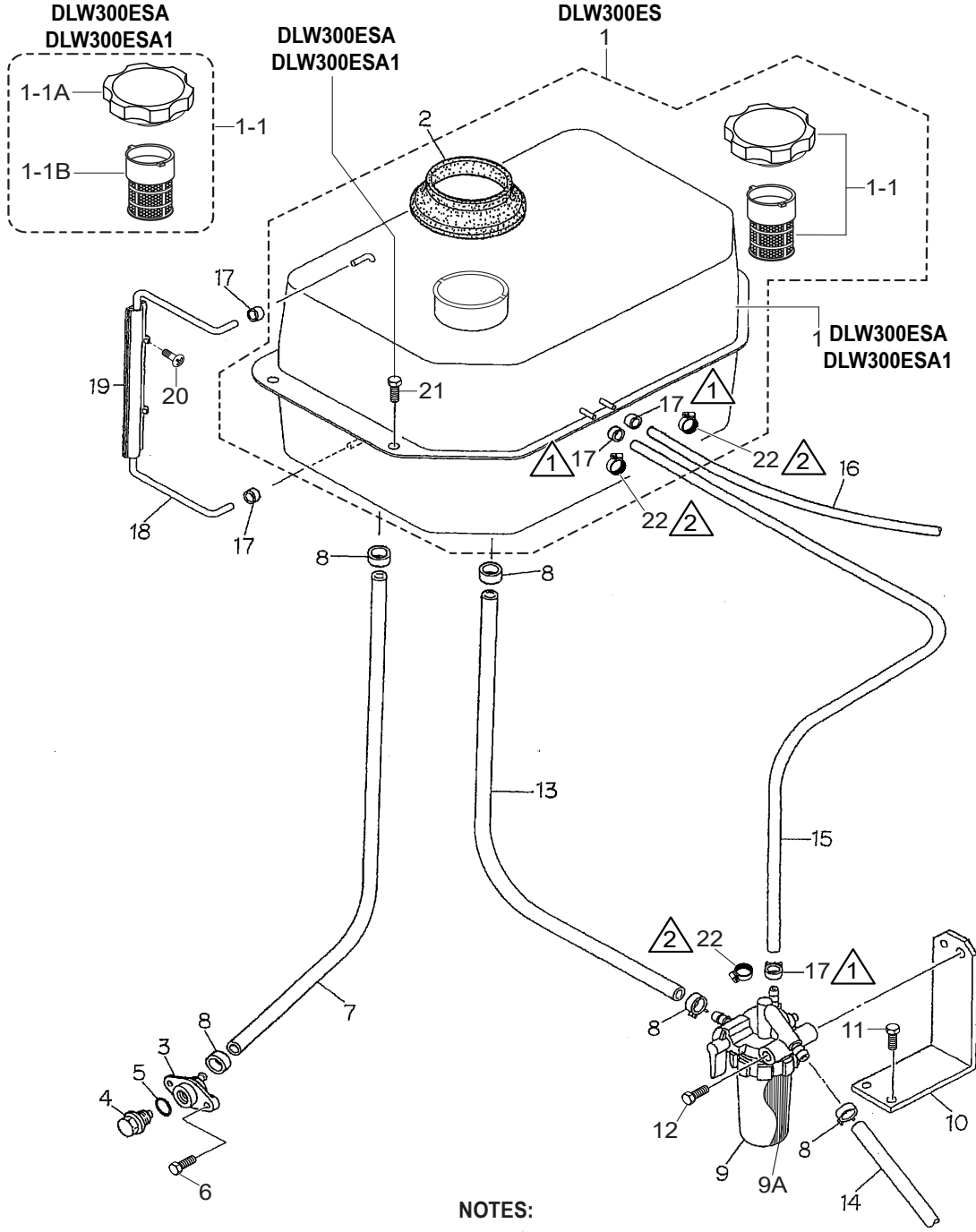

NOTES:

- 1 ITEM 17 FOR DLW300ES, DLW300ESA AND DLW300ESA1 WITH S/N 5678512 AND BELOW.
- 2 ITEM 22 FOR DLW300ESA AND DLW300ESA1 WITH S/N 5678513 AND ABOVE.

FUEL TANK ASSY.

<u>NO.</u>	<u>PART NO.</u>	<u>PART NAME</u>	<u>QTY.</u>	<u>REMARKS</u>
1	D4364000003	FUEL TANK, (DLW-300ES).....	1	INCLUDES ITEMS W/\$
1	D4364000203	FUEL TANK, (DLW-300ESA/ESA1)	1	
1-1\$	0810100813	CAP AND FILTER, FUEL TANK (DLW-300ES)	1	
1-1	A9924800024	FUEL TANK CAP ASSY. (DLW-300ESA/ESA1).....	1	INCLUDES ITEMS W/#
1-1A#	0845500104	CAP, FUEL TANK (DLW-300ESA/ESA1).....	1	REPLACES P/N W0810105800
1-1B#	0810105900	FUEL FILTER (DLW-300ESA/ESA1).....	1	NLA
2	B9312400004	RUBBER SEAL	1	
3	7812014003	DRAIN JOINT	1	
4	0802011104	PLUG	1	
5	0150000018	O-RING, P-18	1	
6	0016906020	HEX. HEAD BOLT (DLW-300ES)	2	
6	0016906015	HEX. HEAD BOLT (DLW-300ESA/ESA1)	2	
7	0199901100	DRAIN HOSE (DLW-300ES)	1	
7	0199901100	DRAIN HOSE (DLW-300ESA/ESA1).....	1	S/N 5678512 AND BELOW
7	Y0370601100	DRAIN HOSE (DLW-300ESA/ESA1).....	1	S/N 5678513 AND ABOVE
8	0605515094	HOSE BAND, ø12	6	
9	1553143010	FUEL FILTER.....	1	INCLUDES ITEMS W/# REPLACES P/N 1553143012
9A#	1T02143560	ELEMENT, FUEL FILTER.....	1	REPLACES P/N 1523143563
10	D3368700204	BRACKET, FUEL FILTER	1	
11	0016906016	HEX.HEAD BOLT, (DLW-300ES)	2	
11	0016906015	HEX.HEAD BOLT, (DLW-300ESA/ESA1)	2	
12	0016908065	HEX.HEAD BOLT, (DLW-300ES)	2	
12	Y0016908070	HEX.HEAD BOLT, (DLW-300ESA/ESA1)	1	
13	0199900300	SUCTION HOSE (DLW-300ES)	1	
13	0199900300	SUCTION HOSE (DLW-300ESA/ESA1).....	1	S/N 5678512 AND BELOW
13	Y0370600300	SUCTION HOSE (DLW-300ESA/ESA1).....	1	S/N 5678513 AND ABOVE
14	0199900400	SUCTION HOSE (DLW-300ES)	1	
14	0199900400	SUCTION HOSE (DLW-300ESA/ESA1).....	1	S/N 5678512 AND BELOW
14	Y0370600400	SUCTION HOSE (DLW-300ESA/ESA1).....	1	S/N 5678513 AND ABOVE
15	0199700400	RETURN HOSE (DLW-300ES)	1	
15	0199700400	RETURN HOSE (DLW-300ESA/ESA1).....	1	S/N 5678512 AND BELOW
15	Y0370700400	RETURN HOSE (DLW-300ESA/ESA1).....	1	S/N 5678513 AND ABOVE
16	0199700260	RETURN HOSE (DLW-300ES)	1	
16	0199700260	RETURN HOSE (DLW-300ESA/ESA1).....	1	S/N 5678512 AND BELOW
16	Y0370700260	RETURN HOSE (DLW-300ESA/ESA1).....	1	S/N 5678513 AND ABOVE
17	0605515093	HOSE BAND, ø9 (DLW-300ES)	6	
17	0605515093	HOSE BAND, ø9 (DLW-300ESA/ESA1).....	6	S/N 5678512 AND BELOW
17	0605515093	HOSE BAND, ø9 (DLW-300ESA).....	2	S/N 5678513 AND ABOVE
18	0264201070	HOSE, FUEL GAUGE	1	
19	7815511203	BRACKET, FUEL GAUGE	1	
20	0028104012	MACHINE SCREW (DLW-300ES)	2	
20	0029104012	MACHINE SCREW (DLW-300ESA/ESA1).....	2	S/N 5722440 AND BELOW
20	0029804012	MACHINE SCREW (DLW-300-ESA/ESA1).....	2	S/N 5722441 AND ABOVE
21	0016908020	HEX. HEAD BOLT, (DLW-300ESA/ESA1)	4	
22	0605515200	HOSE BAND, ø8 (DLW-300ESA/ESA1).....	4	S/N 5678513 AND ABOVE

ENCLOSURE ASSY.

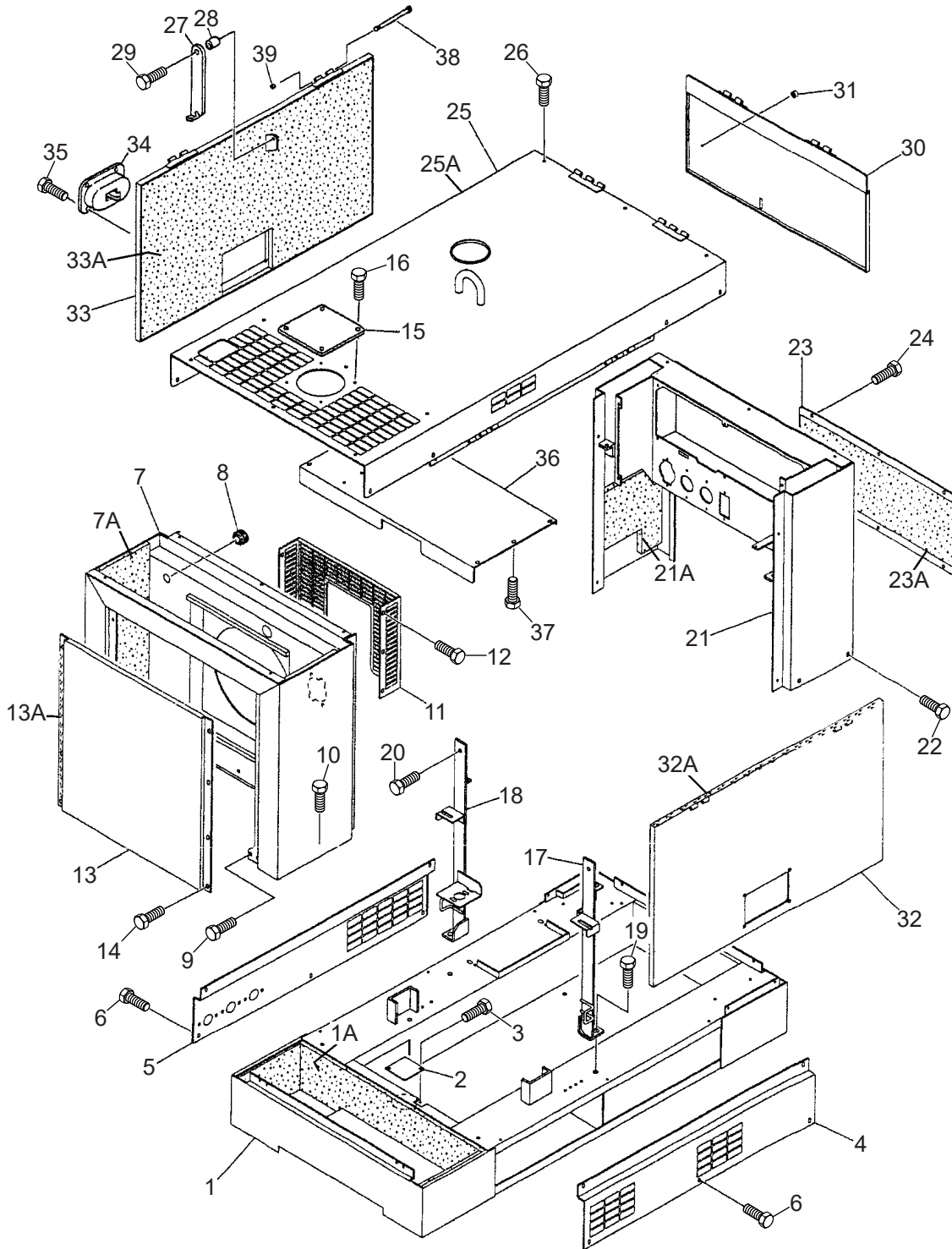

ENCLOSURE ASSY.

<u>NO.</u>	<u>PART NO.</u>	<u>PART NAME</u>	<u>QTY.</u>	<u>REMARKS</u>
1	D4414000302	BASE (DLW-300ES)	1	
1	D4414000702	BASE (DLW-300ESA/ESA1)	1	
1A	D4494000403	LINING (DLW-300ES)	1	
1A	D4494000903	LINING (DLW-300ESA/ESA1)	1	
2	D3414800104	FLOOR PANEL	1	
3	0016906016	HEX. HEAD BOLT (DLW-300ES)	2	
3	0016906015	HEX. HEAD BOLT (DLW-300ESA/ESA1)	2	
4	D4414300603	SPLASHER PANEL (DLW-300ES)	1	
4	D4414301003	SPLASHER PANEL (DLW-300ESA/ESA1)	1	
5	D4414300303	SPLASHER PANEL (DLW-300ES)	1	
5	D4414300903	SPLASHER PANEL (DLW-300ESA/ESA1)	1	
6	0016906016	HEX. HEAD BOLT (DLW-300ES)	16	
6	0016906015	HEX. HEAD BOLT (DLW-300ESA/ESA1)	16	
7	D4424000602	FRONT FRAME	1	
7A	D4494100303	LINING	2	
8	0601850239	GROMMET	1	
9	0016906016	HEX. HEAD BOLT (DLW-300ES)	2	
9	0016906015	HEX. HEAD BOLT (DLW-300ESA/ESA1)	2	
10	011008020	HEX. HEAD BOLT.....	2	REPLACES P/N 0016908020
11	D4311200103	FAN GUARD	1	
12	0016906016	HEX. HEAD BOLT (DLW-300ES)	6	
12	0016906015	HEX. HEAD BOLT (DLW-300ESA/ESA1)	6	
13	D4424200303	COVER, FRONT FRAME	1	
13A	D4494100303	LINING	1	
14	0016906016	HEX. HEAD BOLT (DLW-300ES)	8	
14	0016906015	HEX. HEAD BOLT (DLW-300ESA/ESA1)	8	
15	D4425200804	COVER, RADIATOR CAP	1	
16	0016906016	HEX. HEAD BOLT (DLW-300ES)	4	
16	0016906015	HEX. HEAD BOLT (DLW-300ESA/ESA1)	4	
17	D4434300403	HANGER (DLW-300ES)	1	
17	D4434300803	HANGER (DLW-300ESA/ESA1)	1	
18	D4434300503	HANGER	1	
19	0012312030	HEX. HEAD BOLT	2	
20	0012312030	HEX. HEAD BOLT	2	
21	D4444000802	REAR FRAME (DLW-300ES)	1	
21	D4444001002	REAR FRAME (DLW-300ESA/ESA1).....	1	S/N 5655215 AND BELOW
21	D4444001012	REAR FRAME (DLW-300ESA/ESA1).....	1	S/N 5655216 AND ABOVE
21A	D4494300604	LINING (DLW-300ES)	1	
21A	D4494301304	LINING (DLW-300ESA/ESA1)	1	

ENCLOSURE ASSY. (CONT'D.)

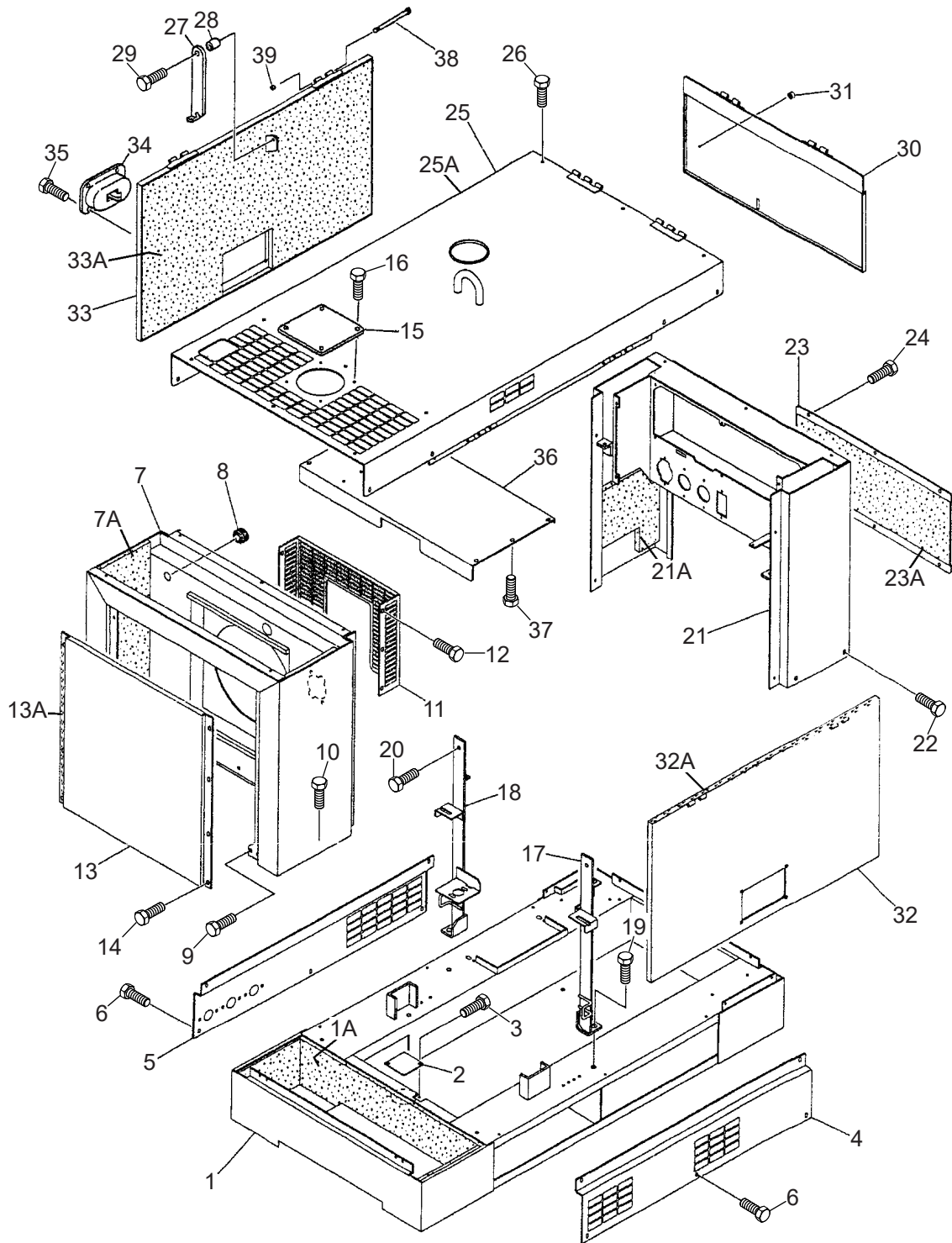

ENCLOSURE ASSY. (CONT'D.)

<u>NO.</u>	<u>PART NO.</u>	<u>PART NAME</u>	<u>QTY.</u>	<u>REMARKS</u>
22	0016906016	HEX. HEAD BOLT (DLW-300ES)	4	
22	0016906015	HEX. HEAD BOLT (DLW-300ESA/ESA1)	4	
23	D4444300404	COVER, REAR FRAME (DLW-300ES)	1	
23	D4444300604	COVER, REAR FRAME (DLW-300ESA/ESA1)	1	
23A	D4494300504	LINING (DLW-300ES)	1	
23A	D4494301404	LINING (DLW-300ESA/ESA1)	1	
24	0016906016	HEX. HEAD BOLT (DLW-300ES)	6	
24	0016906015	HEX. HEAD BOLT (DLW-300ESA/ESA1)	8	
25	D4464000302	ROOF PANEL (DLW-300ES)	1	
25	D4464000502	ROOF PANEL (DLW-300ESA/ESA1)	1	
25A	D4494500204	LINING (DLW-300ES)	1	
25A	D4494500704	LINING (DLW-300ESA/ESA1)	1	
26	0016906016	HEX. HEAD BOLT (DLW-300ES)	17	
26	0016906015	HEX. HEAD BOLT (DLW-300ESA/ESA1)	21	
27	7835186014	DOOR STAY	2	
28	7835088004	COLLAR	2	
29	0017108030	HEX. HEAD BOLT (DLW-300ES)	1	
29	011208030	HEX. HEAD BOLT (DLW-300ESA/ESA1).....	2.....	REPLACES P/N 0017108030
30	D4444200203	REAR DOOR (DLW-300ES)	1	
30	D4444200303	REAR DOOR (DLW-300ESA/ESA1)	1	
31	0601851613	RUBBER STOPPER	2	
32	D4454000603	SIDE DOOR	1	
32A	D4494400604	LINING (DLW-300ES)	1	
32A	D4494401604	LINING (DLW-300ESA/ESA1)	1	
33	D4454000503	SIDE DOOR (DLW-300ES)	1	
33	D4454000903	SIDE DOOR (DLW-300ESA/ESA1)	1	
33A	D4494400604	LINING (DLW-300ES)	1	
33A	D4494401604	LINING (DLW-300ESA/ESA1)	1	
34	B9114000002	DOOR HANDLE	2	
35	0021806020	MACHINE SCREW	8	
36	D4464400003	DUCT (DLW-300ES)	1	
37	0016906016	HEX.HEAD BOLT (DLW-300ES)	6	
38	0810014704	PIN	6	
39	0080200004	SNAP RING	6	

RUBBER SEALS ASSY.

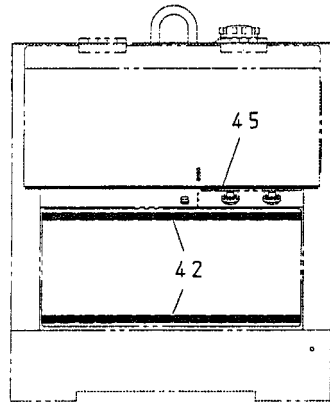
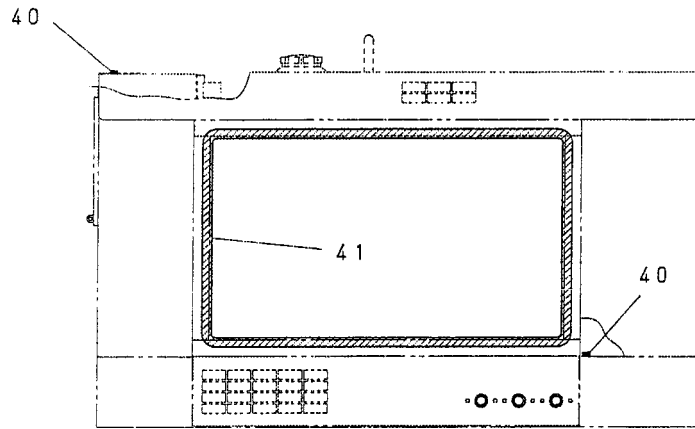
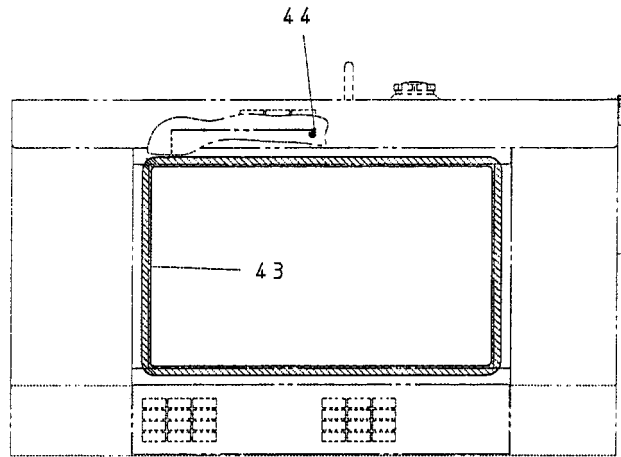

RUBBER SEALS ASSY.

<u>NO.</u>	<u>PART NO.</u>	<u>PART NAME</u>	<u>QTY.</u>	<u>REMARKS</u>
40	0314900680	RUBBER SEAL	2	
41	0314602390	RUBBER SEAL (DLW-300ES)	1	
41	Y0314602370	RUBBER SEAL (DLW-300ESA/ESA1)	1	
42	0314900550	RUBBER SEAL (DLW-300ES)	2	
42	Y0228300560	RUBBER SEAL (DLW-300ESA/ESA1)	2	
43	0314602345	RUBBER SEAL	1	
44	0314900620	RUBBER SEAL (DLW-300ES)	1	
44	0228300215	RUBBER SEAL (DLW-300ESA/ESA1)	2	
45	0226900620	RUBBER SEAL	1	

NAMEPLATE AND DECALS ASSY.

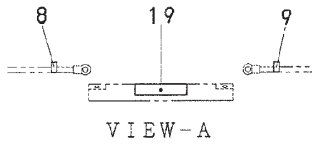

NOTES:

- ① FOR ALL DLW300ES. FOR DLW300ESA, DLW300ESA1 WITH S/N 5804074 AND BELOW.
- ② FOR DLW300ESA, DLW300ESA1 WITH S/N 5804075 AND ABOVE.
- ③ FOR DLW300ES. FOR DLW300ESA, DLW300ESA1 WITH S/N 5825233 AND BELOW.
- ④ FOR DLW300ESA, DLW300ESA1 WITH S/N 5825234 AND ABOVE.

DLW300ES

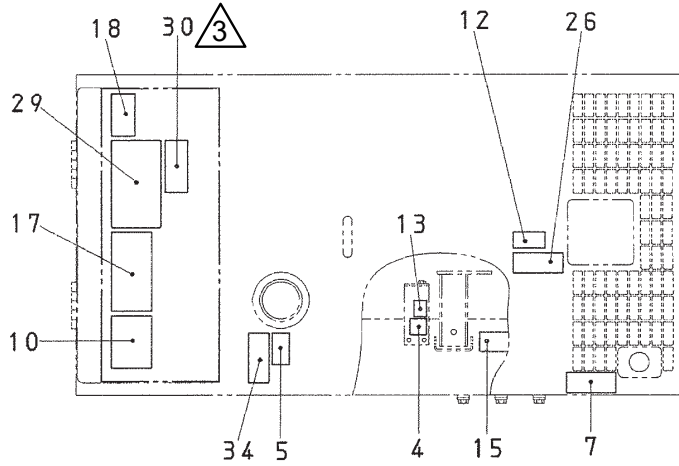
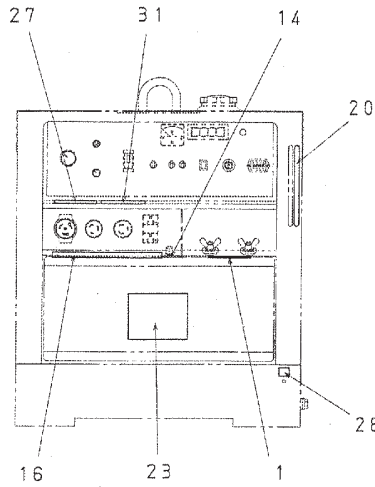

DLW300ESA
DLW300ESA1

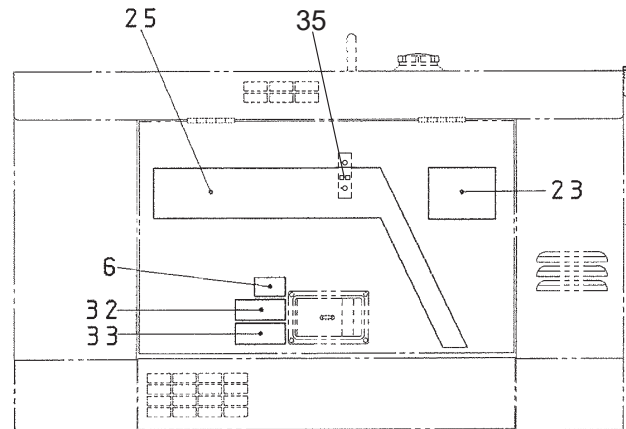
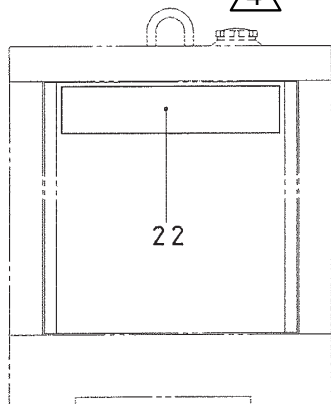
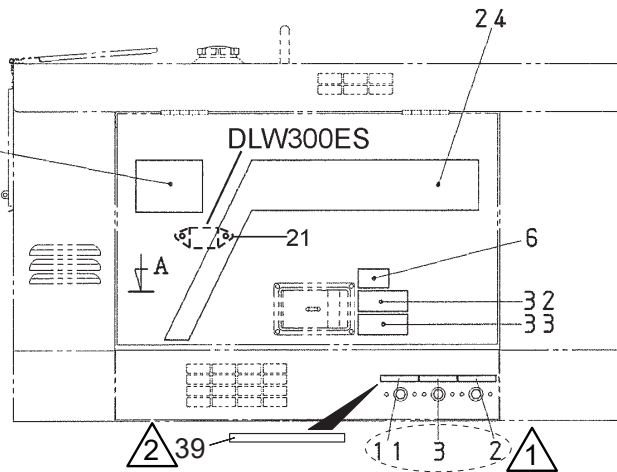
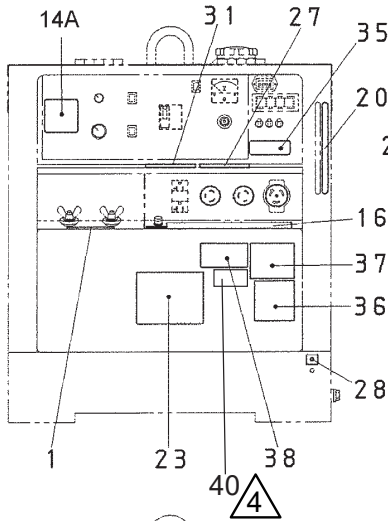

NAMEPLATE AND DECALS ASSY.

<u>NO.</u>	<u>PART NO.</u>	<u>PART NAME</u>	<u>QTY.</u>	<u>REMARKS</u>
1	0800690804	DECAL: WELDING OUTPUT TERMINAL	1	S-1238A
2	1630645004	DECAL: OIL DRAIN	1	S-1403 (DLW-300ES)
2	1630645004	DECAL: OIL DRAIN	1	S-1403(DLW-300ESA/ESA1) S/N 5804074 AND BELOW
3	1630647004	DECAL: COOLANT DRAIN	1	S-1404 (DLW-300ES)
3	1630647004	DECAL: COOLANT DRAIN	1	S-1404 (DLW-300ESA/ESA1) S/N 5804074 AND BELOW
4	1630610404	DECAL: CAUTION, FUEL FILTER.....	1	S-1406
5	1630680004	DECAL: USE #2 DIESEL FUEL ONLY	1	S-1408 (DLW-300ES)
5	B9504501204	DECAL: USE #2 DIESEL FUEL ONLY	1	B90450120 (DLW-300ESA/ESA1) S/N 5647004 AND BELOW
5	B9504501214	DECAL: USE #2 DIESEL FUEL ONLY	1	B90450121 (DLW-300ESA/ESA1) S/N 5647005 AND ABOVE
6	1630610504	DECAL: CAUTION, DOOR.....	2	S-1409
7	8700611804	DECAL: WARNING, EXHAUST GAS	1	S-4984
8	0800689404	DECAL: BATTERY CABLE (+)	1	S-2090
9	0800689504	DECAL: BATTERY CABLE (-)	1	S-2091
10	6390671104	DECAL: IMPORTANT "CHECK DAILY"	1	S-2377
11	7810680104	DECAL: FUEL DRAIN.....	1	S-3060 (DLW-300ES)
11	7810680104	DECAL: FUEL DRAIN.....	1	S-3060 (DLW-300ESA/ESA1) S/N 5804074 AND BELOW
12	7810680204	DECAL: COOLING WATER.....	1	S-3061
13	1630680104	DECAL: FUEL COCK.....	1	S-1407
14	7670624004	DECAL: GROUND FOR G. F. C. I.....	1	S-3821 (DLW-300ES)
14A	D4551002403	DECAL: CONTROL PANEL	1	(DLW-300ESA/ESA1)
15	8700611524	DECAL: CAUTION, OIL REFUELING.....	1	S-4926B
16	8700620113	DECAL: AC POWER OUTPUT	1	S-4935A (DLW-300ES)
16	D5551001703	DECAL: AC POWER OUTPUT	1	D55100170 (DLW-300ESA/ESA1) S/N 5611920 AND BELOW
16	D4551002603	DECAL: AC POWER OUTPUT	1	D45100260 (DLW-300ESA/ESA1) S/N 5611921 AND ABOVE
17	8700611613	DECAL: OPERATING PROCEDURE	1	S-4937A
18	0820610404	DECAL: WARNING, GENERATOR	1	S-3627
19	0820650604	DECAL: CAUTION, BATTERY (YUASA).....	1	ST-CL7B
20	8700615204	DECAL: FUEL GAUGE	1	S-4638A
21	8700625504	DECAL: FUSE BOX.....	1	S-4936 (DLW-300ES)
22	D4562000502	DECAL: STICKER	1	D46200050 (DLW-300ES)
22	D4561000302	DECAL: STICKER	1	D46100030 (DLW-300ESA/ESA1)
23	D3561000104	STRIPE: MQ POWER	3	
24	D4561100303	STRIPE: A.....	1	(DLW-300ES)
24	D4561100403	STRIPE: A.....	1	(DLW-300ESA/ESA1)
25	D4561100403	STRIPE: B.....	1	(DLW-300ES)
25	D4561100303	STRIPE: A.....	1	(DLW-300ESA/ESA1)

NAMEPLATE AND DECALS ASSY. (CONT'D.)

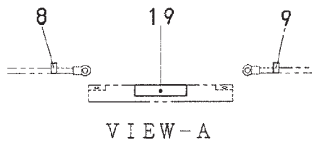

NOTES:

- ① FOR ALL DLW300ES. FOR DLW300ESA, DLW300ESA1 WITH S/N 5804074 AND BELOW.
- ② FOR DLW300ESA, DLW300ESA1 WITH S/N 5804075 AND ABOVE.
- ③ FOR DLW300ES. FOR DLW300ESA, DLW300ESA1 WITH S/N 5825233 AND BELOW.
- ④ FOR DLW300ESA, DLW300ESA1 WITH S/N 5825234 AND ABOVE.

DLW300ES

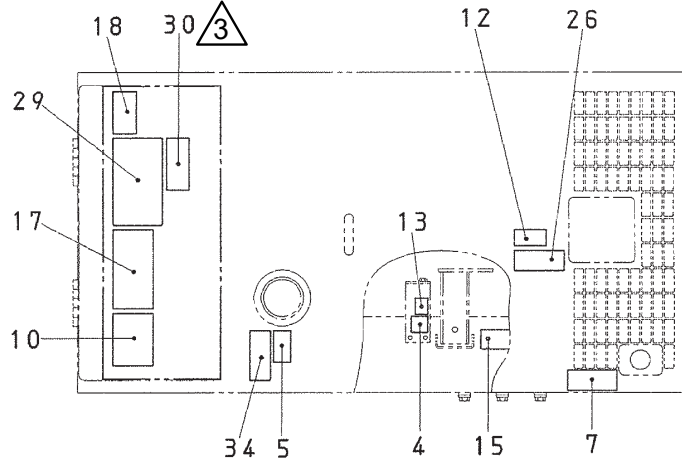
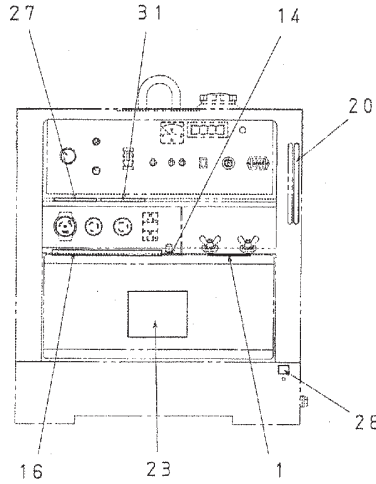

DLW300ESA
DLW300ESA1

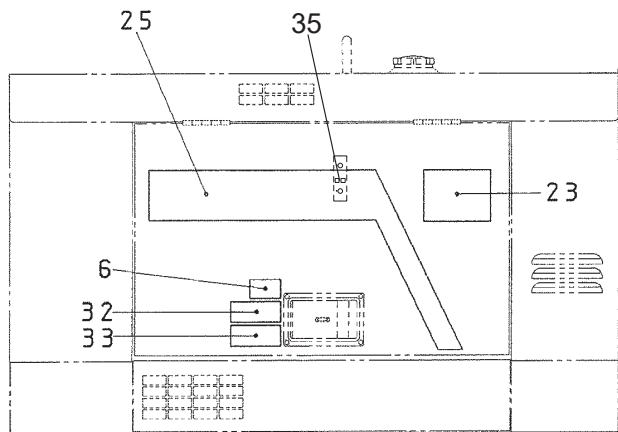
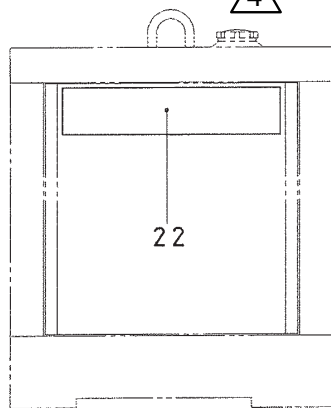
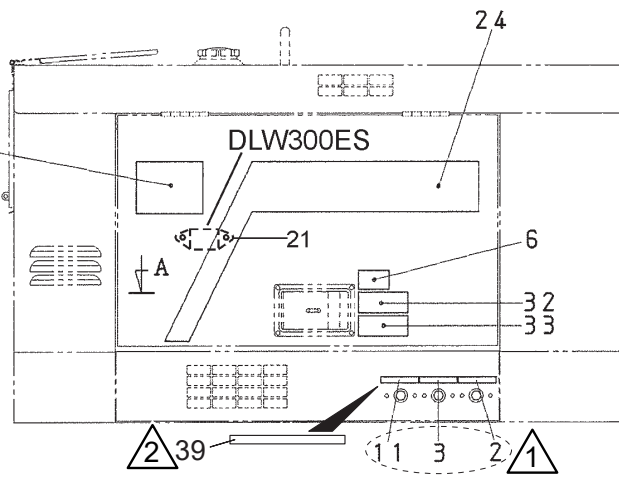
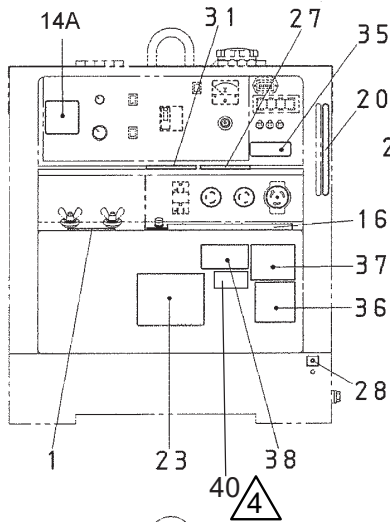

NAMEPLATE AND DECALS ASSY. (CONT'D.)

<u>NO.</u>	<u>PART NO.</u>	<u>PART NAME</u>	<u>QTY.</u>	<u>REMARKS</u>
26	B9514100104	DECAL: RADIATOR CAP	1.....	B91410010 (DLW-300ES)
26	B9504100104	DECAL: RADIATOR CAP	1.....	B90410010 (DLW-300ESA/ESA1)
27	8700611904	DECAL: WARNING ELECT SHOCK HAZARD..	1.....	S-4985
28	0800628504	DECAL: GROUND	1.....	S-1123
29	D9512100203	DECAL: WARNING (ARC).....	1.....	B91210020A
30	DCL160	DECAL: WARNING (PROPOSITION 65)	1.....	D92210020 (DLW-300ES) REPLACES P/N D9522100204
30	DCL160	DECAL: WARNING (PROPOSITION 65)	1.....	D92210020 (DLW-300ESA/ESA1) REPLACES P/N D9522100204 S/N 5825233 AND BELOW
31	B9511100304	DECAL: WARNING.....	1.....	B91110030
32	B9504000304	DECAL: CAUTION, HOT PARTS.....	1.....	B90400030
33	B9504000404	DECAL: CAUTION, MOVING PARTS.....	1.....	B90400040
34	B9504500004	DECAL: WARNING, DIESEL FUEL.....	1.....	B90450000
35	D4551001204	DECAL: OUTPUT LIMIT	1.....	D45100120 (DLW-300ES)
35	D4551002304	DECAL: OUTPUT LIMIT	1.....	D45100230 (DLW-300ESA/ESA1)
36	D9531100004	DECAL: DANGER ELECTROCUTION.....	1.....	D93110000 (DLW-300ESA/ESA1)
37	A9504000014	DECAL: WARNING, EXHAUST GAS	1.....	A90400001 (DLW-300ESA/ESA1)
38	920214100	DECAL: WARNING START FIRES.....	1.....	NPA-1410 (DLW-300ESA/ESA1) S/N 5619868 AND ABOVE REPLACES P/N M9504200004
39	D5551007704	DECAL: FUEL, WATER, OIL DRAIN	1.....	D55100770 (DLW-300ESA/ESA1) S/N 5804075 AND ABOVE
40	A9511101304	DECAL: WARNING, PROPOSITION 65.....	1.....	A91110130 (DLW-300ESA/ESA1) S/N 5825234 AND ABOVE

PARTS MANUAL

HERE'S HOW TO GET HELP

PLEASE HAVE THE MODEL AND SERIAL
NUMBER ON-HAND WHEN CALLING

UNITED STATES

Multiquip Inc.

(310) 537- 3700
6141 Katella Avenue Suite 200
Cypress, CA 90630
E-MAIL: mq@multiquip.com
WEBSITE: www.multiquip.com

CANADA

Multiquip

(450) 625-2244
4110 Industriel Boul.
Laval, Quebec, Canada H7L 6V3
E-MAIL: infocanada@multiquip.com

UNITED KINGDOM

Multiquip (UK) Limited Head Office

0161 339 2223
Unit 2, Northpoint Industrial Estate,
Globe Lane,
Dukinfield, Cheshire SK16 4UJ
E-MAIL: sales@multiquip.co.uk

© COPYRIGHT 2026, MULTIQUIP INC.

Multiquip Inc. and the MQ logo are registered trademarks of Multiquip Inc. and may not be used, reproduced, or altered without written permission. All other trademarks are the property of their respective owners and used with permission.

This manual MUST accompany the equipment at all times. This manual is considered a permanent part of the equipment and should remain with the unit if resold.

DISCLAIMER: Product features, descriptions, and specifications are based on published information at the time of publication and are subject to change at any time without notice. Multiquip Inc. and its affiliates reserve the right to change specifications, features, design, and descriptions of products at any time without notice.

