

# PARTS MANUAL



**SmartStick**<sup>TM</sup>

**MODEL DLW330X2  
WELDER/GENERATOR  
(KUBOTA D902E4BWDDE2 DIESEL ENGINE)**

**REF. NO. D4844301264**

Revision #8 (04/12/23)

To find the latest revision of this publication  
or associated operation manual, visit our  
website at: [www.multiquip.com](http://www.multiquip.com)



**THIS MANUAL MUST ACCOMPANY THE EQUIPMENT AT ALL TIMES.**

# TABLE OF CONTENTS

---

## **DLW330X2 Welder-Generator**

Explanation Of Code In Remarks Column..... 4  
Suggested Spare Parts ..... 5

### **Component Drawings**

Generator Assembly ..... 6-7  
Control Panel, Upper Assembly..... 8-11  
Control Panel, Lower Assembly..... 12-13  
Electric Parts (1) Assembly..... 14-17  
Electric Parts (2) Assembly..... 18-19  
Engine And Radiator Assembly ..... 20-21  
Battery Assembly ..... 22-23  
Muffler Assembly ..... 24-25  
Fuel Tank Assembly..... 26-27  
Enclosure Assembly ..... 28-31  
Rubber Seals Assembly ..... 32-33  
Nameplate And Decals Assembly..... 34-37

**NOTICE**  
Specifications and part numbers are subject to change without notice.



# EXPLANATION OF CODE IN REMARKS COLUMN

The following section explains the different symbols and remarks used in the Parts section of this manual. Use the help numbers found on the back page of the manual if there are any questions.

## NOTICE

The contents and part numbers listed in the parts section are subject to change without notice. Multiquip does not guarantee the availability of the parts listed.

## SAMPLE PARTS LIST

NO.	PART NO.	PART NAME
1	12345	BOLT .....1 .....INCLUDES ITEMS W/%
2%		WASHER, 1/4 IN. ....NOT SOLD SEPARATELY
2%	12347	WASHER, 3/8 IN. ...1 .....MQ-45T ONLY
3	12348	HOSE .....A/R ...MAKE LOCALLY
4	12349	BEARING .....1 .....S/N 2345B AND ABOVE

## NO. Column

**Unique Symbols** — All items with same unique symbol (@, #, +, %, or >) in the number column belong to the same assembly or kit, which is indicated by a note in the “Remarks” column.

**Duplicate Item Numbers** — Duplicate numbers indicate multiple part numbers, which are in effect for the same general item, such as different size saw blade guards in use or a part that has been updated on newer versions of the same machine.

## NOTICE

When ordering a part that has more than one item number listed, check the remarks column for help in determining the proper part to order.

## PART NO. Column

**Numbers Used** — Part numbers can be indicated by a number, a blank entry, or TBD.

TBD (To Be Determined) is generally used to show a part that has not been assigned a formal part number at the time of publication.

A blank entry generally indicates that the item is not sold separately or is not sold by Multiquip. Other entries will be clarified in the “Remarks” Column.

## QTY. Column

**Numbers Used** — Item quantity can be indicated by a number, a blank entry, or A/R.

A/R (As Required) is generally used for hoses or other parts that are sold in bulk and cut to length.

A blank entry generally indicates that the item is not sold separately. Other entries will be clarified in the “Remarks” Column.

## REMARKS Column

Some of the most common notes found in the “Remarks” Column are listed below. Other additional notes needed to describe the item can also be shown.

**Assembly/Kit** — All items on the parts list with the same unique symbol will be included when this item is purchased.

Indicated by:

“INCLUDES ITEMS W/(unique symbol)”

**Serial Number Break** — Used to list an effective serial number range where a particular part is used.

Indicated by:

“S/N XXXXX AND BELOW”

“S/N XXXX AND ABOVE”

“S/N XXXX TO S/N XXX”

**Specific Model Number Use** — Indicates that the part is used only with the specific model number or model number variant listed. It can also be used to show a part is NOT used on a specific model or model number variant.

Indicated by:

“XXXXX ONLY”

“NOT USED ON XXXX”

**“Make/Obtain Locally”** — Indicates that the part can be purchased at any hardware shop or made out of available items. Examples include battery cables, shims, and certain washers and nuts.

**“Not Sold Separately”** — Indicates that an item cannot be purchased as a separate item and is either part of an assembly/kit that can be purchased, or is not available for sale through Multiquip.

## SUGGESTED SPARE PARTS

### DLW330X2 WELDER/GENERATOR

1 to 3 units

Qty.	P/N	Description
1.....	D4311500204	HOSE, RADIATOR UPPER
1.....	D4311500303	HOSE, RADIATOR LOWER
1.....	.0602011079	CAP, RADIATOR
1.....	A9924800024	CAP, FUEL TANK
6.....	.0602042463	FILTER, FUEL
6.....	.0602042174	FILTER, FUEL ELEMENT
3.....	.0602046391	FILTER, AIR ELEMENT
1.....	1747297011	FAN BELT
1.....	.0601806433	CIRCUIT BREAKER, 2P 20A
1.....	.0601806424	CIRCUIT BREAKER, 1P 30A
1.....	.0601806425	CIRCUIT BREAKER, 2P 30A
1.....	.0601820664	AUTOMATIC VOLTAGE REG.
1.....	.0601840219	RHEOSTAT (VOLT. REG.)
1.....	.0601840103	KNOB, RHEOSTAT
1.....	.0601840095	RHEOSTAT (WELD. REG.)
1.....	.0601840100	KNOB, RHEOSTAT
1.....	.0601840170	KNOB, RHEOSTAT TIME REG.
5.....	.0601806642	FUSE, 5A
5.....	.0601806643	FUSE, 15A
5.....	.0601806646	FUSE, 20A
5.....	.0601806640	FUSE, 65A

#### NOTICE

Part numbers on this Suggested Spare Parts list may supersede/replace the part numbers shown in the following parts lists.

### KUBOTA D902E3BWDDE2 DIESEL ENGINE

1 to 3 units

Qty.	P/N	Description
5.....	1585332435	CARTRIDGE, OIL FILTER
1.....	1584139010	SWITCH, OIL
4.....	1685165512	GLOW PLUG
2.....	1753883040	SWITCH, THERMO.

# GENERATOR ASSY.

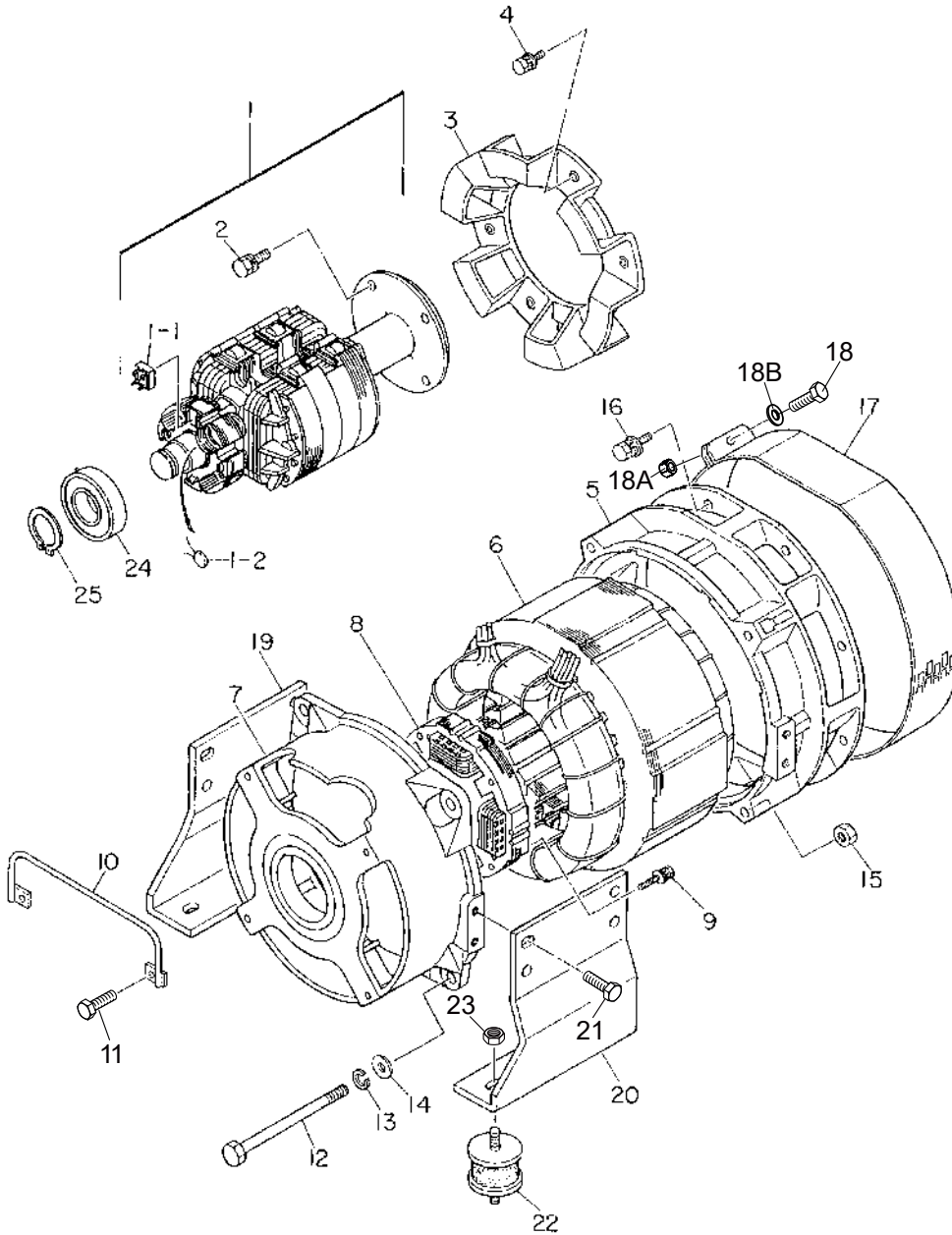

# GENERATOR ASSY.

<u>NO.</u>	<u>PART NO.</u>	<u>PART NAME</u>	<u>QTY.</u>	<u>REMARKS</u>
1	D4110000203	ROTOR ASSY.....	1.....	INCLUDES ITEMS W/#
1-1#	0601820037	RECTIFIER	1	
1-2#	0601822638	SURGE ABSORBER .....	1.....	S/N 5851491 AND BELOW
1-2#	0601822692	SURGE ABSORBER .....	1.....	S/N 5851492 AND ABOVE
2	0012410030	HEX. HEAD BOLT	4	
3	D4111100103	FAN	1	
4	0017108025	HEX. HEAD BOLT	6	
5	D4153100102	END BRACKET	1	
6	D4134002503	ARMATURE ASSY.	1	
7	D4153000202A	END BRACKET .....	1.....	REPLACES P/N D4153000202
8	D4139000003	FIELD ASSY., EXCITER	1	
9	0017105035	HEX. HEAD BOLT	4	
10	D4185300004	BRACKET	1	
11	0016908020	HEX. HEAD BOLT	2	
12	D4131200004	SET BOLT	4	
13	0040012000	WASHER, LOCK	4	
14	0041212000	WASHER, FLAT	4	
15	0030012000	HEX. NUT	4	
16	0012410025	HEX. HEAD BOLT	8	
17	D4155400204	COVER, FAN	1	
18	0340406040	HEX. HEAD BOLT	1	
18A	0037906000	HEX. NUT	1	
18B	952404470	WASHER, FLAT .....	1.....	REPLACES P/N 0041206000
19	D2131100203-1	GENERATOR FOOT.....	1.....	REPLACES P/N D2131100203
20	D2131100103-1	GENERATOR FOOT.....	1.....	REPLACES P/N D2131100103
21	0012310025	HEX. HEAD BOLT	8	
22	7605419004A	RUBBER SUSPENSION .....	2.....	REPLACES P/N 7605419004
23	0207010000	HEX. NUT	2	
24	0071206307	BEARING	1	
25	0080000035	SNAP RING	1	

# CONTROL PANEL, UPPER ASSY.

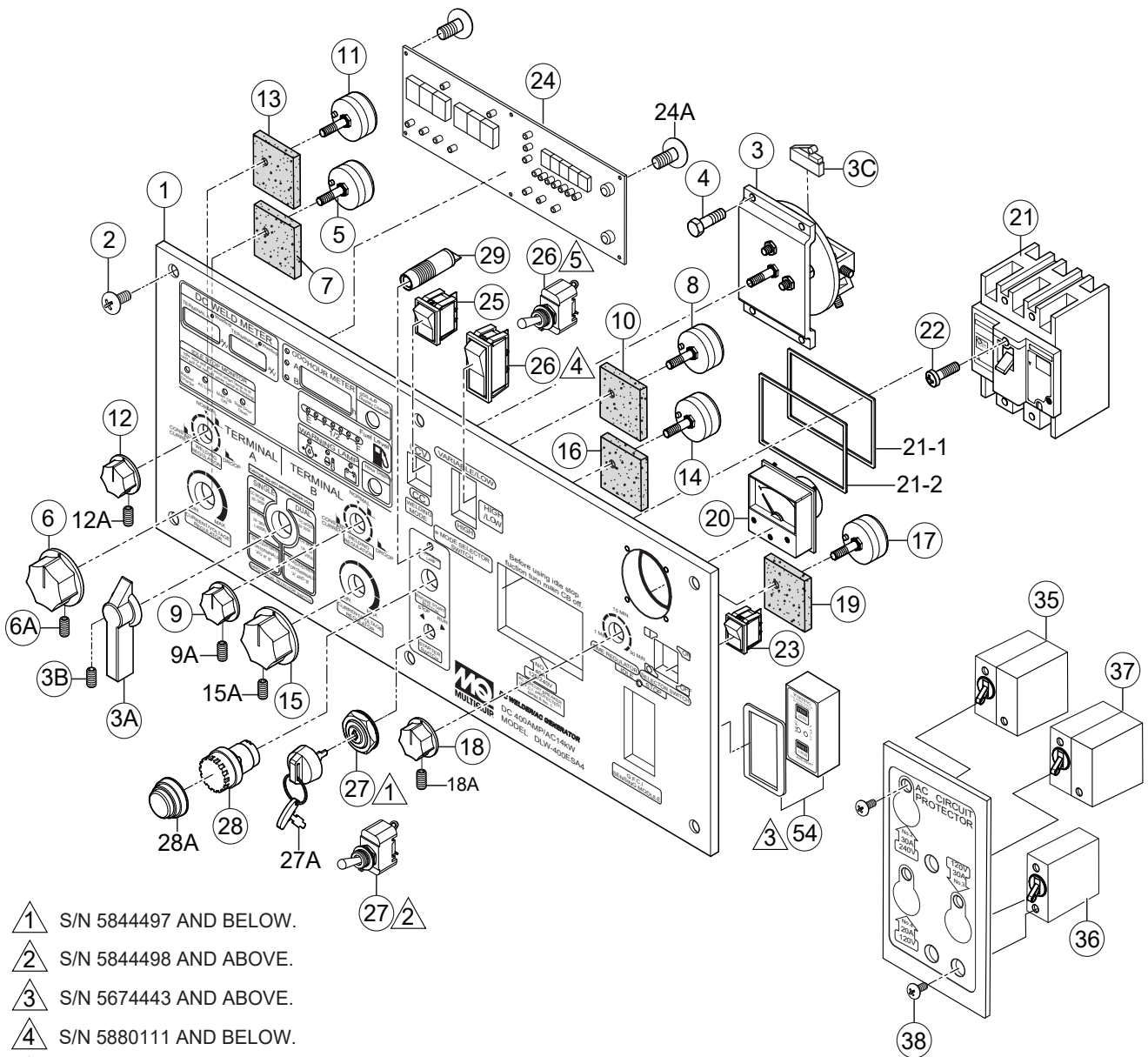

- ① S/N 5844497 AND BELOW.
- ② S/N 5844498 AND ABOVE.
- ③ S/N 5674443 AND ABOVE.
- ④ S/N 5880111 AND BELOW.
- ⑤ S/N 5880112 AND ABOVE.



## CONTROL PANEL, UPPER ASSY.

<u>NO.</u>	<u>PART NO.</u>	<u>PART NAME</u>	<u>QTY.</u>	<u>REMARKS</u>
1	D2511300602	CONTROL PANEL .....	1	S/N 5674442 AND BELOW
1	D2511301302	CONTROL PANEL .....	1	S/N 5674443 TO 5844497
1	D2511301312	CONTROL PANEL .....	1	S/N 5844498 TO 5880111
1	D2511301322	CONTROL PANEL .....	1	S/N 5880112 AND ABOVE
2	0021806030	MACHINE SCREW	6	
3	0601803075	SELECTOR SWITCH .....	1	INCLUDES ITEMS W/#
3A#	0601803116	HANDLE	1	
3B#	0025104018	SET SCREW	1	
3C#	0601830014	MICRO SWITCH	1	
4	0017106015	HEX HEAD BOLT	4	
5	0601840219	RHEOSTAT (CURRENT/VOLTAGE REG.)	1	
6	0601840103	KNOB	1	
6A	0023304008	SET SCREW	2	
7	0801883003	INSULATOR	1	
8	0601840219	RHEOSTAT (CURRENT/VOLTAGE REG.)	1	
9	0601840103	KNOB	1	
9A	0023304008	SET SCREW	2	
10	0801883003	INSULATOR	1	
11	0601840095	RHEOSTAT (WELDING REGULATION)	1	
12	0601840100	KNOB	1	
12A	0023303508	SET SCREW	2	
13	0801883003	INSULATOR	1	
14	0601840095	RHEOSTAT (WELDING REGULATION)	1	
15	0601840100	KNOB	1	
15A	0023303508	SET SCREW	2	
16	0801883003	INSULATOR	1	
17	0601840095	RHEOSTAT (TIME REGULATOR)	1	
18	0601840170	KNOB	1	
18A	0023303508	SET SCREW	1	
19	0801883003	INSULATOR	1	
20	0601800281	AC VOLTMETER	1	
21	0601806473	CIRCUIT BREAKER .....	1	S/N 5674442 AND BELOW
21	0601806486	CIRCUIT BREAKER .....	1	S/N 5674443 AND ABOVE
21-1	0317900080	RUBBER SEAL	2	
21-2	D5491400204	RUBBER SEAL	1	
22	0027504055	MACHINE SCREW	2	
23	0601831600	SWITCH, IDLE STOP SELECTOR	1	
24	D4266204114	DIGITAL PANEL .....	1	REPLACES P/N D4266204104
24A	0027103005	MACHINE SCREW	6	
25	0601831600	SWITCH, WELDING MODE SELECTOR	1	
26	0601831605	SWITCH, E MODE SELECTOR .....	1	S/N 5880111 AND BELOW
26	Y0601831379	SWITCH, E MODE SELECTOR .....	1	S/N 5880112 AND ABOVE
27	0602100310	STARTER SWITCH .....	1	INCLUDES ITEMS W/\$ S/N 5844497 AND BELOW
27	0601830731	STARTER SWITCH .....	1	S/N 5844498 AND ABOVE
27A\$	0602100240	KEY .....	2	S/N 5844497 AND BELOW

# CONTROL PANEL, UPPER ASSY. (CONT'D.)

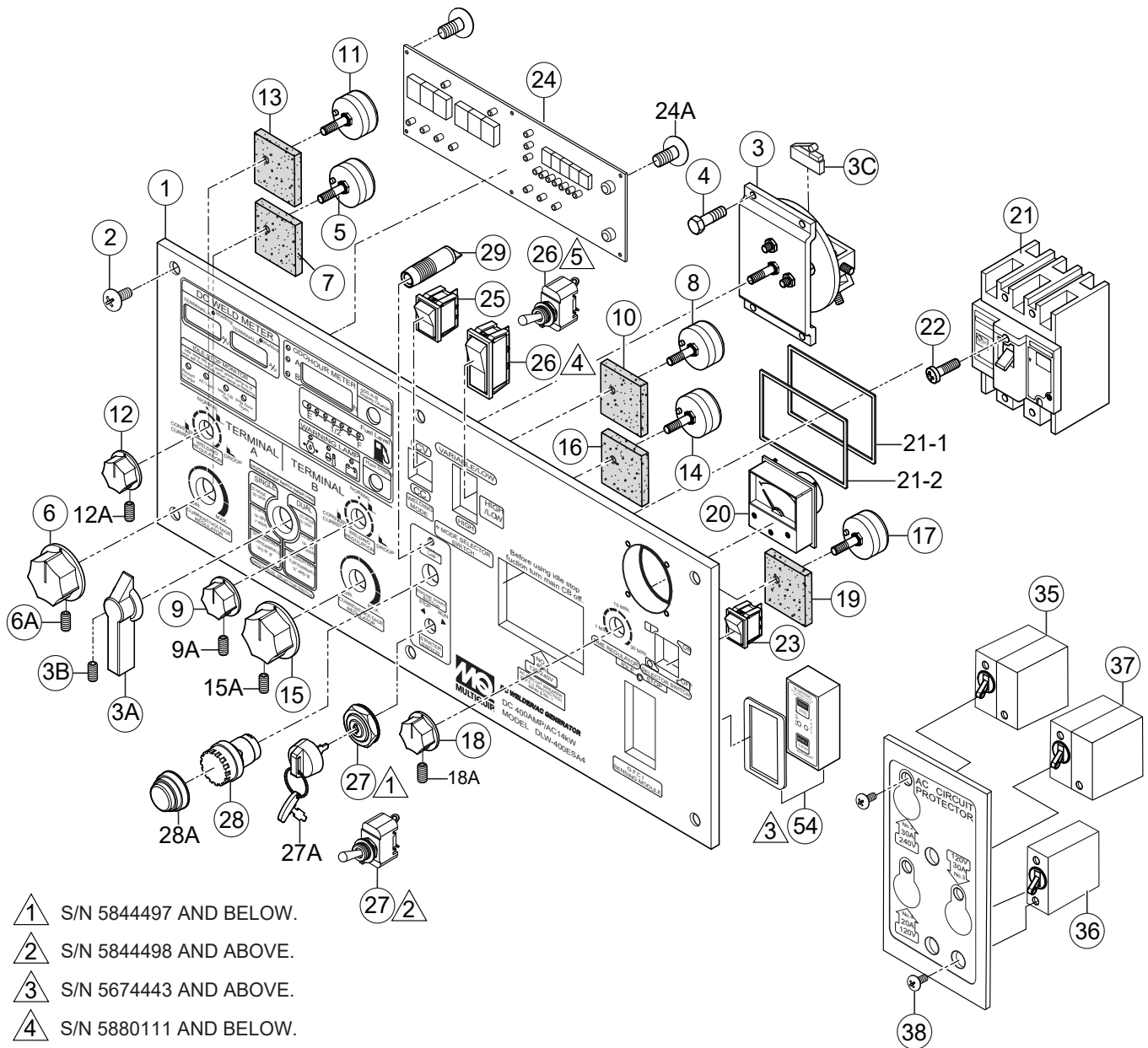

- ① S/N 5844497 AND BELOW.
- ② S/N 5844498 AND ABOVE.
- ③ S/N 5674443 AND ABOVE.
- ④ S/N 5880111 AND BELOW.
- ⑤ S/N 5880112 AND ABOVE.

## **CONTROL PANEL, UPPER ASSY. (CONT'D.)**

---

<u>NO.</u>	<u>PART NO.</u>	<u>PART NAME</u>	<u>QTY.</u>	<u>REMARKS</u>
28	0601831966	ENGINE START BUTTON	1	
28A	0601832048	CAP	1	
29	0601814114	LAMP .....	1.....	S/N 5866962 AND BELOW
29	0601816708	LAMP .....	1.....	S/N 5866963 AND ABOVE
35	0601806433	CIRCUIT BREAKER, 2P 20A	1	
36	0601806424	CIRCUIT BREAKER, 1P 30A	1	
37	0601806425	CIRCUIT BREAKER, 2P 30A	1	
38	0021003005	MACHINE SCREW	6	
54	0601829301	GFCI SENSING MODULE, GFSM120A.....	1.....	S/N 5674443 ~ 5911174
54	0601829302	GFCI SENSING MODULE, PGFM-111-B-A1.....	1.....	S/N 5911175 AND ABOVE

# CONTROL PANEL, LOWER ASSY.

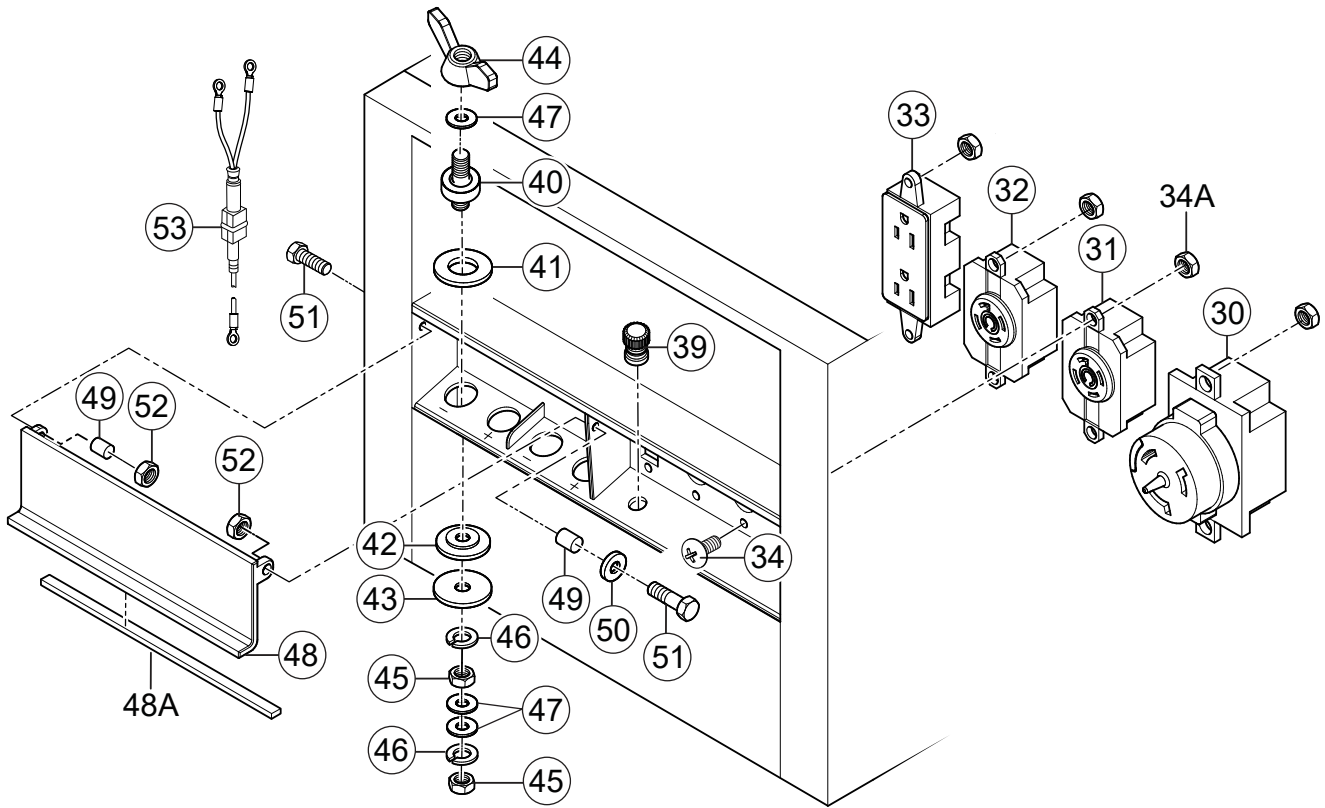

## CONTROL PANEL, LOWER ASSY.

<u>NO.</u>	<u>PART NO.</u>	<u>PART NAME</u>	<u>QTY.</u>	<u>REMARKS</u>
30	0601812565	RECEPTACLE, CS6369 .....	1	S/N 5674442 AND BELOW
30	0601814014	RECEPTACLE, CS6369LM2 .....	1	S/N 5674443 AND ABOVE
31	0601811033	RECEPTACLE, L6-30R	1	
32	0601811035	RECEPTACLE, L5-30R	1	
33	0601814013	RECEPTACLE, 5-20R GF20LA .....	1	S/N 5797110 AND BELOW
33	0601814024	RECEPTACLE, 5-20R GFRST20DEN.....	1	S/N 5797111 TO 5863497
33	0601814034	RECEPTACLE, 5-20R GFWR2-E.....	1	S/N 5863498 AND ABOVE
34	0027104015	MACHINE SCREW	8	
34A	0207004000	HEX. NUT	8	
39	0601815109	GROUND TERMINAL	1	
40	0801888204	OUTPUT TERMINAL, WELDING	4	
41	0801840104	INSULATOR WASHER	4	
42	0801840004	INSULATOR WASHER	4	
43	6109170	SET WASHER, OUTPUT TERMINAL.....	4	REPLACES P/N 0801841204
44	022910220	WING NUT.....	4	REPLACES P/N 0801884004
45	0039512000	HEX. NUT	8	
46	0042212000	WASHER, LOCK	8	
47	0041412000	WASHER, FLAT	12	
48	D2237100103	COVER, OUTPUT TERMINAL	1	
48A	D2237400104	RUBBER SHEET	1	
49	0821800014	COLLAR.....	2	REPLACES P/N W0821800014
50	D9311200004	STAY RUBBER	1	
51	0016906020	HEX. HEAD BOLT	2	
52	0038706000	HEX. NUT	2	
53	D4268304704	NOISE FILTER	2	

# ELECTRIC PARTS (1) ASSY.

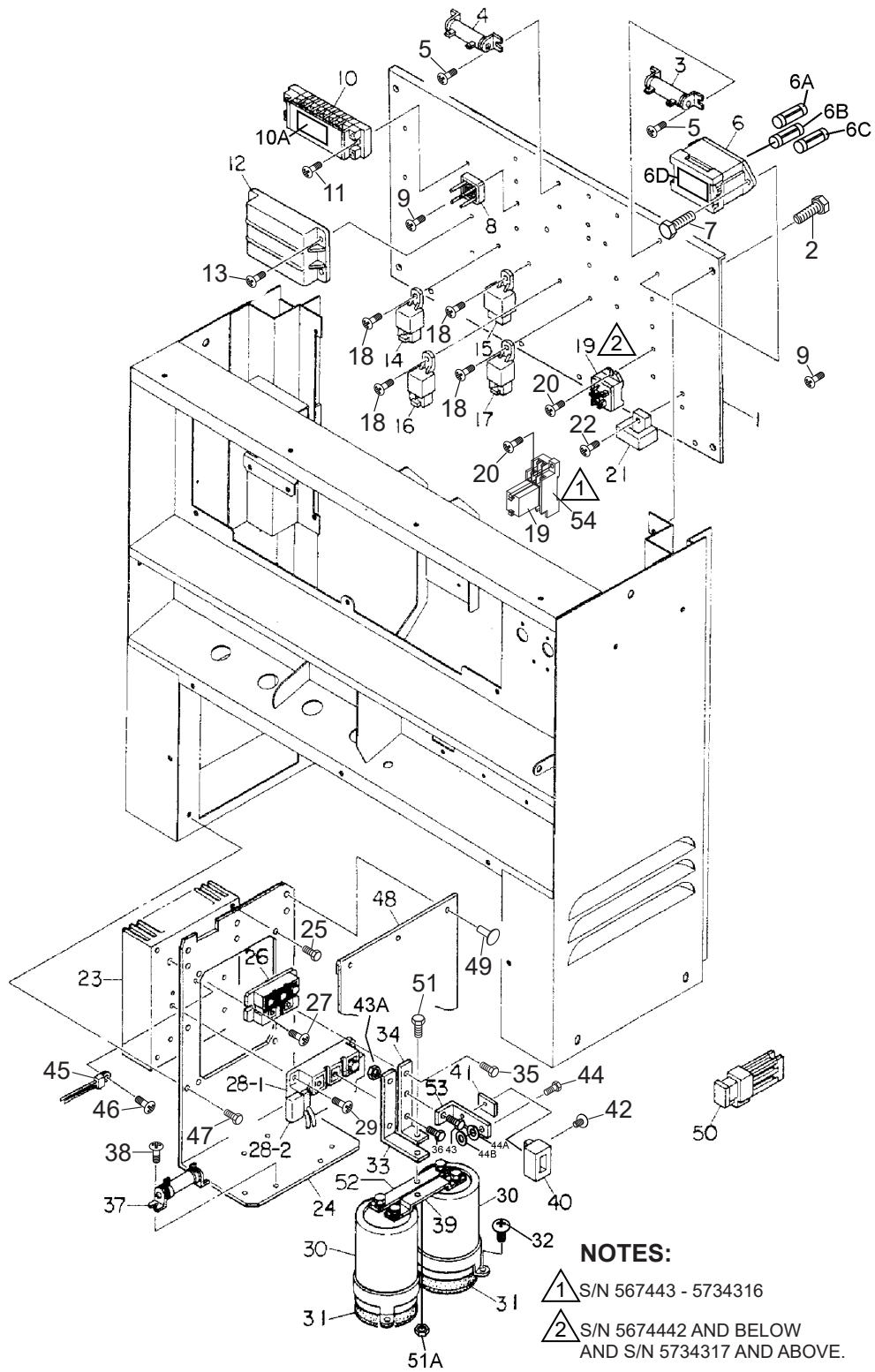

## ELECTRIC PARTS (1) ASSY.

<u>NO.</u>	<u>PART NO.</u>	<u>PART NAME</u>	<u>QTY.</u>	<u>REMARKS</u>
1	D2260500203	SET PANEL, ELECTRIC PARTS	1	
2	0016906015	HEX. HEAD BOLT	4	
3	0601842349	RESISTOR, 20W, 35Ω	1	
4	0601842262	RESISTOR, 20W, 1KΩ	2	
5	0027104015	MACHINE SCREW	6	
6	D2214600004	FUSE BOX.....	1.....	INCLUDES ITEMS W/#
6A#	0601806642	FUSE, 5A	3	
6B#	0601806643	FUSE, 15A	2	
6C#	0601806646	FUSE, 20A	2	
6D#	D2551001104	DECAL; FUSE BOX	1	
7	0016905015	HEX. HEAD BOLT	2	
8	0601823204	RECTIFIER	2	
9	0027103015	MACHINE SCREW	2	
10	0601815422	TERMINAL BOARD	1	
10A	D9521000704	DECAL; SYMBOL MARK	1	
11	0027104025	MACHINE SCREW	2	
12	1747260606	EMERGENCY UNIT.....	1.....	REPLACES P/N 0602200475
13	0027105025	MACHINE SCREW	4	
14	6888153542	STARTER RELAY .....	1.....	REPLACES P/N 0602202566
15	5H63242511	GLOW RELAY .....	1.....	REPLACES P/N Y0602202632
16	6888153542	RELAY .....	1.....	REPLACES P/N 0602202566
17	0601823707	RELAY	1	
18	0027105015	MACHINE SCREW	4	
19	0601827604	RELAY .....	2.....	S/N 5674442 AND BELOW
19	0601820915	RELAY .....	1.....	S/N 5674443 TO 5734316
19	0601820901	RELAY .....	2.....	S/N 5734317 AND ABOVE
20	0027104015	MACHINE SCREW.....	4.....	S/N 5674442 AND BELOW
20	0027104020	MACHINE SCREW.....	2.....	S/N 5674443 TO 5734316
20	0027104015	MACHINE SCREW.....	4.....	S/N 5734317 AND ABOVE
21	0601804203	DC CURRENT TRANSFORMER	1	
22	0027104015	MACHINE SCREW	1	
23	D2266300004	COOLING FIN	2	
24	D2261600104	BRACKET	2	
25	0016906015	HEX. HEAD BOLT	8	
26	0601823228	RECTIFIER	2	
27	0027105012	MACHINE SCREW	4	
28	D4268000403	IGBT MODULE ASSY. ....	2.....	INCLUDES ITEMS W/%
28-1%	0601821258	IGBT MODULE	2	
28-2%	D9925800044	IGBT PROTECTIVE UNIT	2	
29	0027105012	MACHINE SCREW	8	
30	0601826146	CONDENSER, 160V 10K μF	4	

# ELECTRIC PARTS (1) ASSY. (CONT'D.)

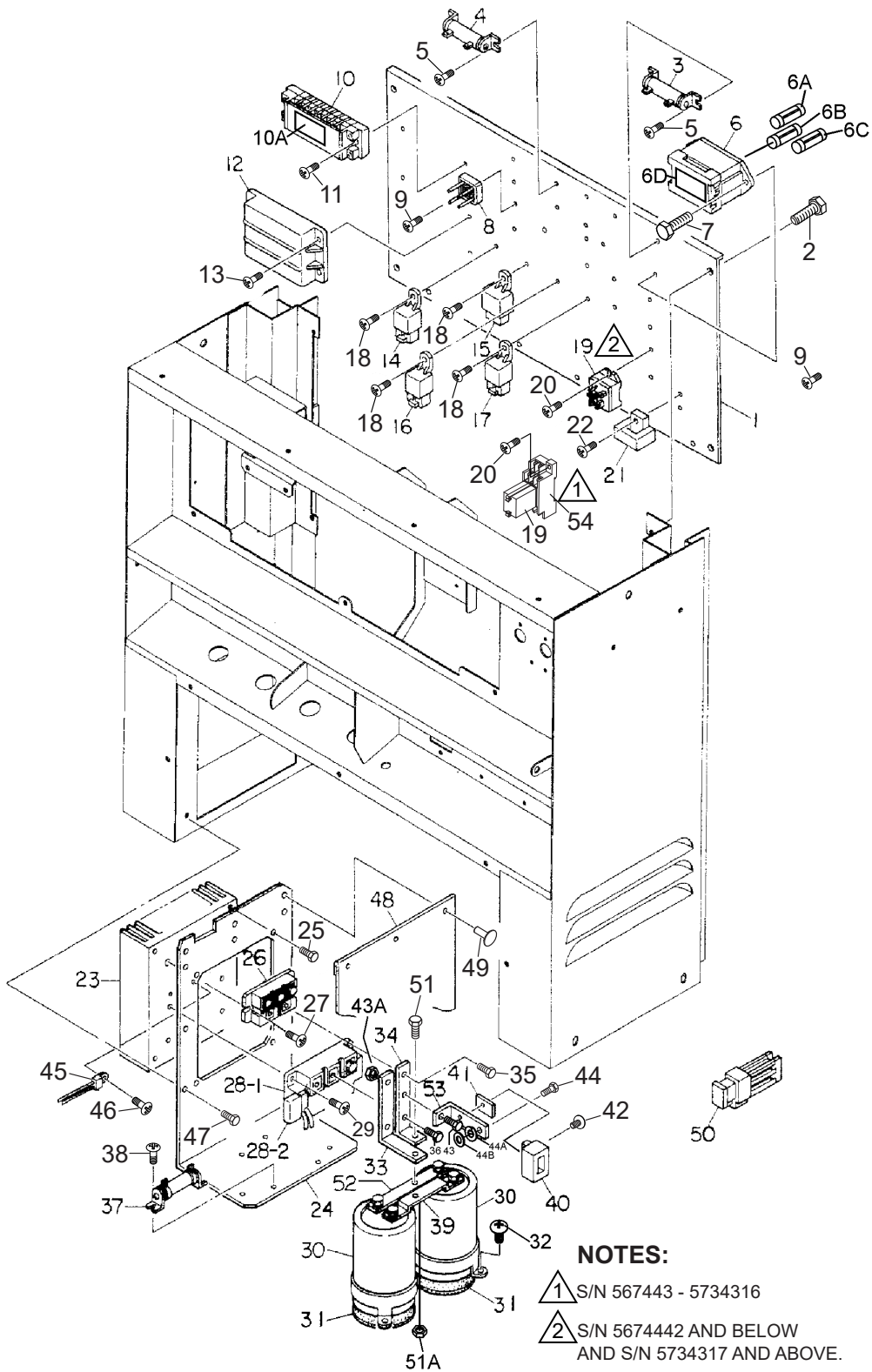



## ELECTRIC PARTS (1) ASSY. (CONT'D.)

<u>NO.</u>	<u>PART NO.</u>	<u>PART NAME</u>	<u>QTY.</u>	<u>REMARKS</u>
31	D5261800404	INSULATOR RUBBER	4	
32	0027104010	MACHINE SCREW	12	
33	D2267300104	CONNECTION PLATE	2	
34	D2267300004	CONNECTION PLATE	2	
35	0017805012	HEX. HEAD BOLT	10	
36	0017806014	HEX. HEAD BOLT	6	
37	0601842262	RESISTOR, 20W, 1K $\Omega$	2	
38	0027104010	MACHINE SCREW	4	
39	D4268304204	CONNECTION PLATE	2	
40	0601804202	DC CURRENT TRANSFORMER	2	
41	D4235400004	INSULATOR	2	
42	0027104020	MACHINE SCREW	2	
43	0017106020	HEX. HEAD BOLT	2	
43A	0207206000	HEX. NUT	2	
44	0019008015	HEX. HEAD BOLT	2	
44A	0040008000	WASHER, LOCK	2	
44B	0042708000	WASHER, FLAT	2	
45	D2266300104	THERMISTER	2	
46	0021003010	MACHINE SCREW	2	
47	0016906015	HEX. HEAD BOLT	14	
48	D2261700004	COVER, ELECTRIC PARTS	2	
49	0605011412	RIVET	8	
50	0601806640	FUSE, 65A	2	
51	0017106020	HEX. HEAD BOLT	4	
51A	0207006000	HEX. NUT	4	
52	D2267300204	CONNECTION PLATE	2	
53	D2267300404	CONNECTION PLATE	2	
54	0601823174	SOCKET .....	1.....	S/N 5674443 TO 5736090

# ELECTRIC PARTS (2) ASSY.

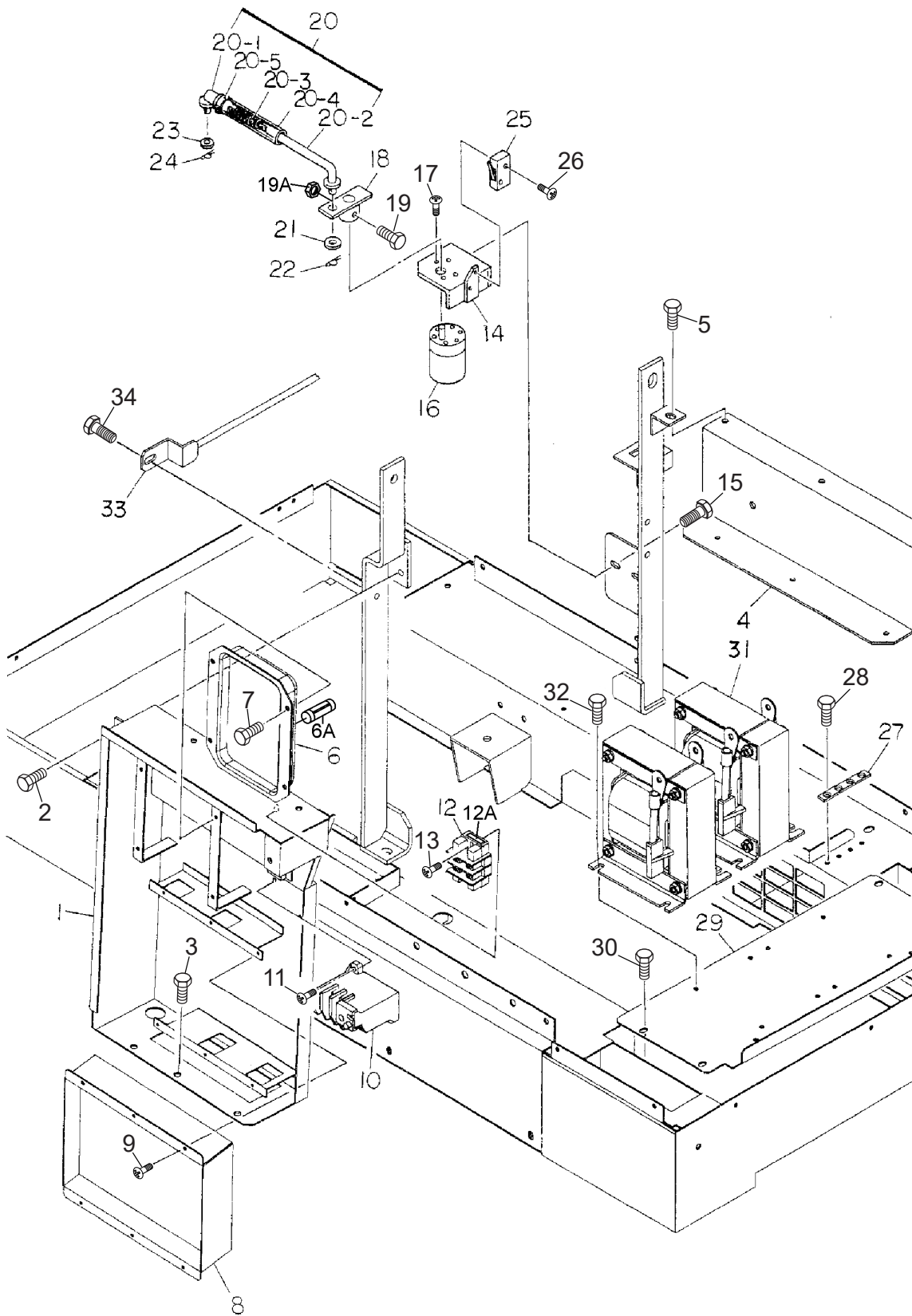

## ELECTRIC PARTS (2) ASSY.

<u>NO.</u>	<u>PART NO.</u>	<u>PART NAME</u>	<u>QTY.</u>	<u>REMARKS</u>
1	D2434000202	SUPPORT, FUEL TANK	1	
2	0016908020	HEX. HEAD BOLT	2	
3	0016906015	HEX. HEAD BOLT	3	
4	D2434000304	SUPPORT, FUEL TANK	1	
5	0016908020	HEX. HEAD BOLT	2	
6	0601820664	AUTOMATIC VOLTAGE REGULATOR	1	
6A	0601806682	FUSE, 5A	1	
7	0016905015	HEX. HEAD BOLT	4	
8	D4266204004	CONTROL UNIT .....	1	S/N 5722493 AND BELOW
8	D4266204014	CONTROL UNIT .....	1	S/N 5722494 TO 5732324
8	D4266204024	CONTROL UNIT .....	1	S/N 5732325 AND ABOVE
9	0027104012	MACHINE SCREW	6	
10	0601820836	OVER CURRENT RELAY	1	
11	0027104015	MACHINE SCREW	2	
12	0601815730	TERMINAL BOARD	1	
12A	D9521002004	DECAL; SYMBOL MARK	1	
13	0027104020	MACHINE SCREW	2	
14	D4355600504	BRACKET, GEARED MOTOR	1	
15	0016906015	HEX. HEAD BOLT	2	
16	0601822721	GEARED MOTOR, 12V	1	
17	0027203006	MACHINE SCREW	4	
18	D4358800014	ARM, GEARED MOTOR	1	
19	0010106020	HEX. HEAD BOLT	1	
19A	0030006000	HEX. NUT	1	
20	D4355000004	GOVERNOR ROD ASSY.	1	
20-1	D4355300304	GOVERNOR ROD	1	
20-2	D4355300204	GOVERNOR ROD	1	
20-3	D4355600404	SPRING	1	
20-4	0264900100	HOSE	1	
20-5	Y0605515227	BAND	1	
21	0041208000	WASHER, FLAT	1	
22	0605010503	SNAP PIN	1	
23	0041206000	WASHER, FLAT	1	
24	0605010502	SNAP PIN	1	
25	0601830370	LIMIT SWITCH	1	
26	0027203015	MACHINE SCREW	2	
27	B1262800004A	PLATE.....	1	REPLACES P/N B1262800004
28	0016906015	HEX. HEAD BOLT	4	
29	D2214100003	BRACKET, REACTOR	1	
30	0016906015	HEX. HEAD BOLT	4	
31	D4263504303	DC REACTOR	2	
32	0016906015	HEX. HEAD BOLT	8	
33	D4261800303	CLAMPER ROD	1	
34	0016908020	HEX. HEAD BOLT	2	

# ENGINE AND RADIATOR ASSY.

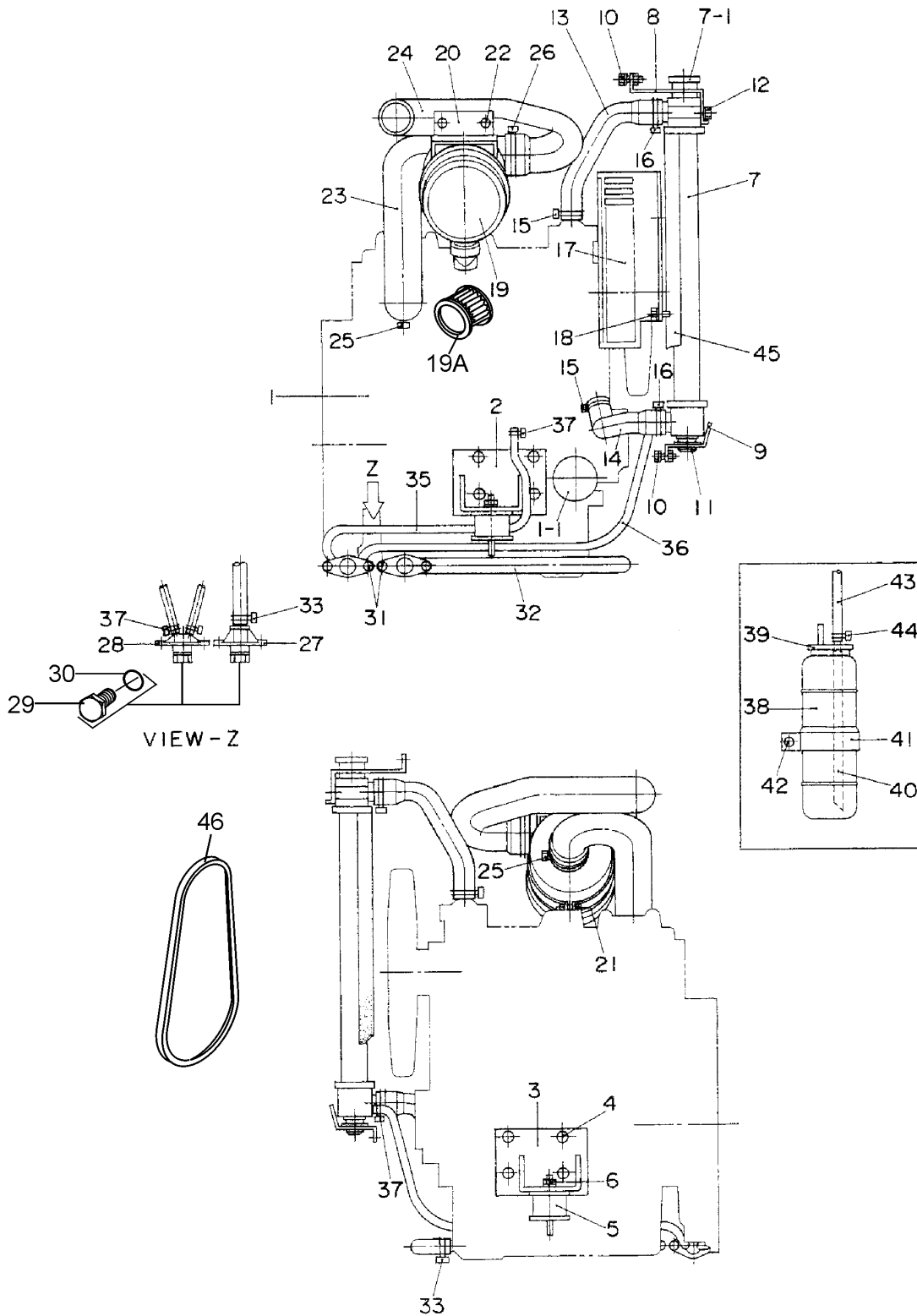

## ENGINE AND RADIATOR ASSY.

<u>NO.</u>	<u>PART NO.</u>	<u>PART NAME</u>	<u>QTY.</u>	<u>REMARKS</u>
1	D2924200034	ENGINE, KUBOTA D902-E3B .....	1.....	S/N 5700046 AND BELOW INCLUDES ITEMS W/#
1	D2924200034	ENGINE, KUBOTA D902-E4B .....	1.....	S/N 5700047 AND ABOVE INCLUDES ITEMS W/%
1-1#%	1585332435	CARTRIDGE, OIL FILTER.....	1.....	REPLACES P/N 0602041273
2	D4304200404	ENGINE FOOT	1	
3	D4304200504	ENGINE FOOT	1	
4	0010710020	HEX. HEAD BOLT	8	
5	7605419004A	RUBBER SUSPENSION .....	2.....	REPLACES P/N W7605419004
6	0207010000	HEX. NUT	2	
7	0602012779	RADIATOR.....	1.....	INCLUDES ITEM W/\$
7-1\$	0602011079	CAP, RADIATOR	1	
8	D4311100304	BRACKET, RADIATOR	1	
9	D4312100813	BRACKET, RADIATOR	1	
10	0016906015	HEX. HEAD BOLT	5	
11	B1312600004	RUBBER MOUNT	2	
12	0016906015	HEX. HEAD BOLT	2	
13	D4311500204	RADIATOR HOSE, UPPER	1	
14	D4311500303	RADIATOR HOSE, LOWER	1	
15	0605515003	HOSE BAND	2	
16	0605515134	HOSE BAND	2	
17	D4311200203	FAN GUARD	1	
18	0016906015	HEX. HEAD BOLT	2	
19	0602046266	AIR CLEANER.....	1.....	INCLUDES ITEMS W/%
19A%	0602046391	ELEMENT, AIR CLEANER	1	
20	W8712031503	BAND, AIR CLEANER	1	
21	0016908025	HEX. HEAD BOLT	1	
22	0016908020	HEX. HEAD BOLT	2	
23	D4374100103	HOSE, AIR CLEANER	1	
24	D4374100003	HOSE, AIR CLEANER	1	
25	0605515021	HOSE BAND	2	
26	0605515021	HOSE BAND	1	
27	1502025103C	DRAIN JOINT, OIL.....	1.....	REPLACES P/N W1502025103
28	1622014103	DRAIN JOINT, WATER	1	
29	0802011104	PLUG	2	
30	0150000018	O-RING	2	
31	0016906015	HEX. HEAD BOLT	4	
32	D2321100003	DRAIN HOSE	1	
33	0605515132	HOSE BAND	2	
35	0199900700	DRAIN HOSE	1	
36	0199900850	DRAIN HOSE	1	
37	0605515094	HOSE BAND	4	
38	0802081403	RESERVE TANK	1	
39	0802081104	CAP, RESERVE TANK	1	
40	0199100215	HOSE	1	
41	6262082304	BRACKET, RESERVE TANK	1	
42	0016906015	HEX. HEAD BOLT	1	
43	0199900460	HOSE	1	
44	0605515094	HOSE BAND	2	
45	0220300375	RUBBER SEAL	2	
46#%	1747297011	FAN BELT .....	1.....	REPLACES P/N 0602011470

**BATTERY ASSY.**

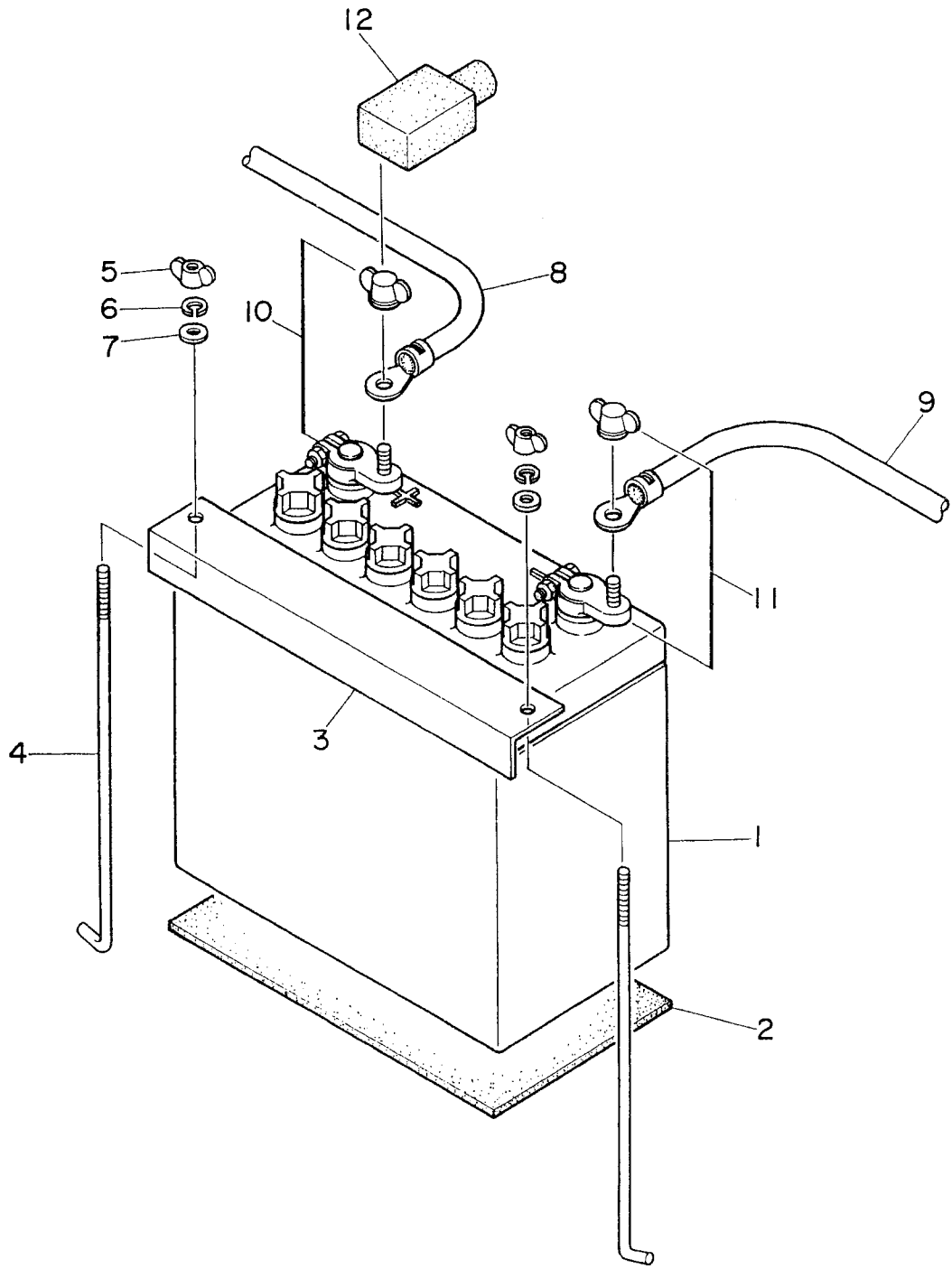

## BATTERY ASSY.

---

<u>NO.</u>	<u>PART NO.</u>	<u>PART NAME</u>	<u>QTY.</u>	<u>REMARKS</u>
1	0166105524	BATTERY	1	
2	8722251004	BATTERY SHEET	1	
3	7552253004	BATTERY BAND	1	
4	7872251004	BATTERY BOLT	2	
5	0037806000	WING NUT	2	
6	0040006000	WASHER, LOCK	2	
7	0041606000	WASHER, FLAT	2	
8		BATTERY CABLE, POSITIVE .....	1	MAKE LOCALLY
9		BATTERY CABLE, NEGATIVE .....	1	MAKE LOCALLY
10	0602220312	TERMINAL ASSY.	1	
11	0602220313	TERMINAL ASSY.	1	
12	0602220600	TERMINAL CAP	1	

# MUFFLER ASSY.

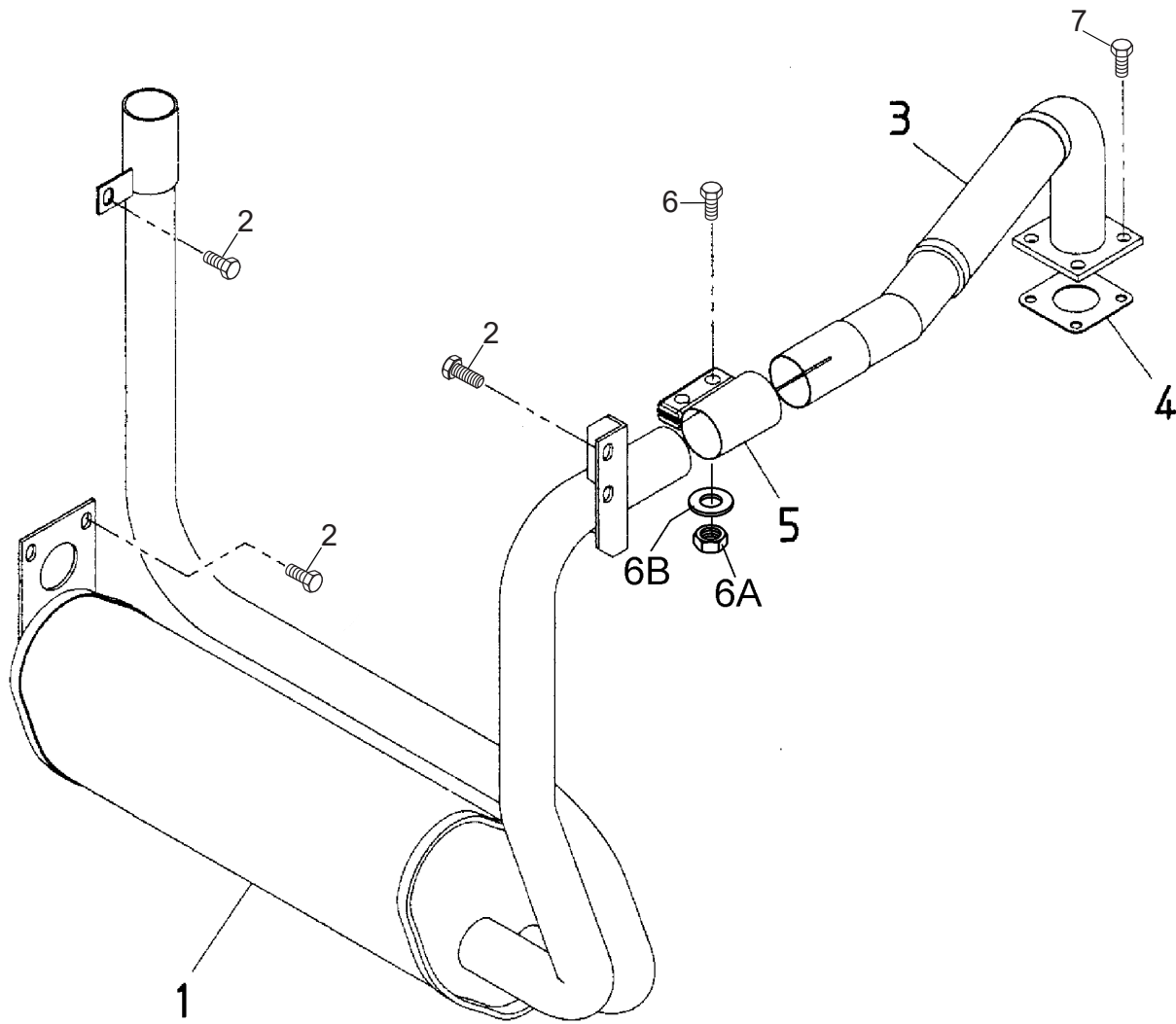



## MUFFLER ASSY.

---

<u>NO.</u>	<u>PART NO.</u>	<u>PART NAME</u>	<u>QTY.</u>	<u>REMARKS</u>
1	D2331100003	MUFFLER	1	
2	0016908020	HEX. HEAD BOLT	5	
3	D4334000203	EXHAUST PIPE	1	
4	1526312370	GASKET .....	1	REPLACES P/N 0602320153
5	0602325094	SEAL CLAMP	1	
6	0341510040	HEX. HEAD BOLT	21	
6A	0207110000	HEX. NUT	2	
6B	0042410000	WASHER, FLAT	2	
7	0207008000	HEX. NUT	4	

# FUEL TANK ASSY.

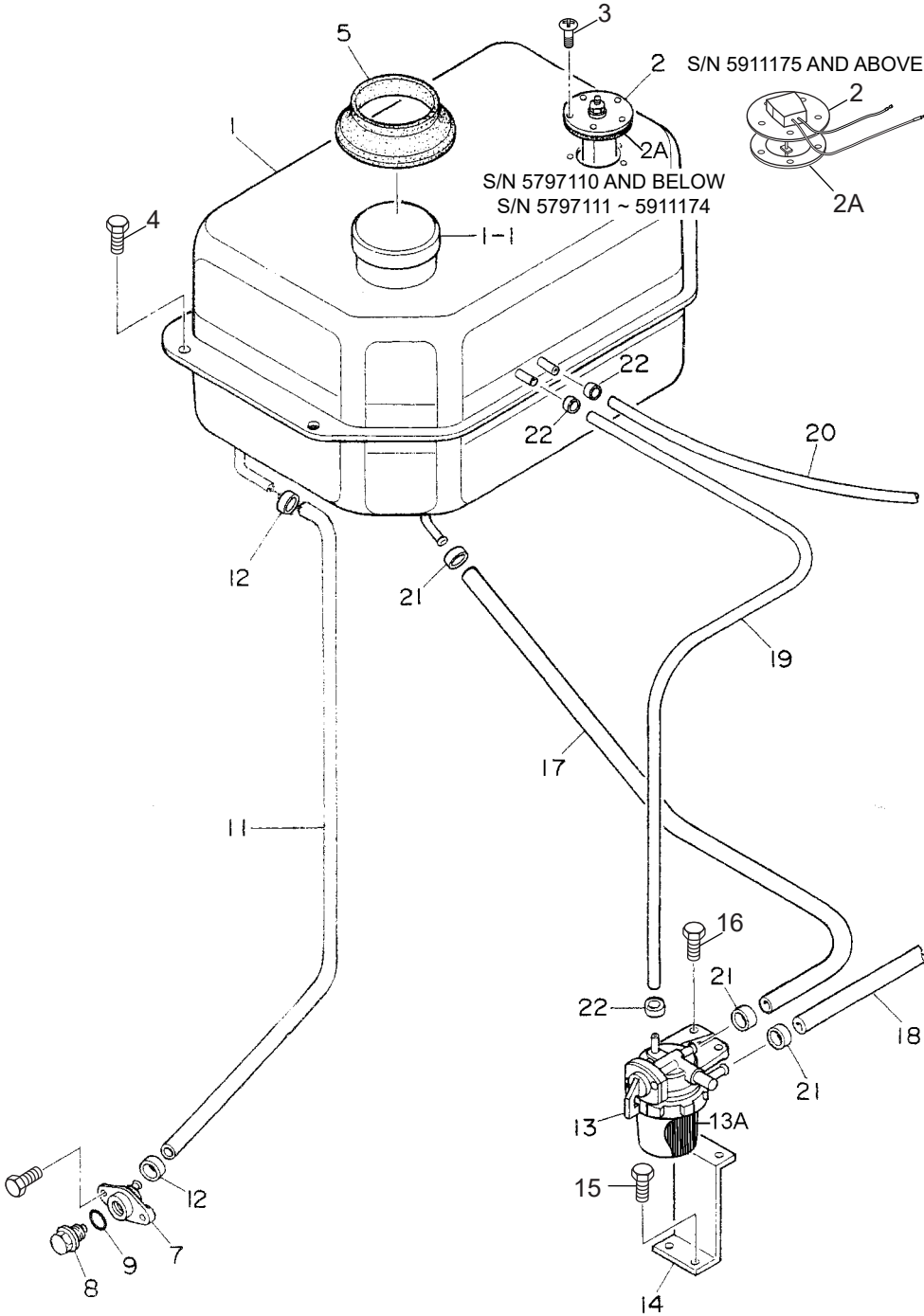

## FUEL TANK ASSY.

<u>NO.</u>	<u>PART NO.</u>	<u>PART NAME</u>	<u>QTY.</u>	<u>REMARKS</u>
1	D2364000103	FUEL TANK	1	
1-1	A9924800024	CAP, FUEL TANK	1	
2	E2924300244	SENDER, FUEL GAUGE .....	1.....	S/N 5797110 AND BELOW
2	B4924300284	SENDER, FUEL GAUGE .....	1.....	S/N 5797111 ~ 5911174
2	B4924300444	SENDER, FUEL GAUGE .....	1.....	S/N 5911175 AND ABOVE
2A	1924300184	GASKET .....	1.....	S/N 5797110 AND BELOW
2A	3924300184	GASKET .....	1.....	S/N 5797111 ~ 5911174
2A	3924300514	GASKET .....	1.....	S/N 59711175 AND ABOVE
3	0022905015	MACHINE SCREW	5	
4	0016908020	HEX. HEAD BOLT	4	
5	B9312400004	RUBBER SEAL	1	
7	7812014003	DRAIN JOINT	1	
8	0802011104	PLUG	1	
9	0150000018	O-RING	1	
10	0016906015	HEX. HEAD BOLT	2	
11	0199900840	DRAIN HOSE.....	1.....	S/N 5686618 AND BELOW
11	0370600840	DRAIN HOSE.....	1.....	S/N 5686619 AND ABOVE
12	0605515094	HOSE BAND	2	
13	1552143017	FUEL FILTER.....	1.....	REPLACES P/N 0602042463
13A	1552143160	ELEMENT, FUEL FILTER .....	1.....	REPLACES P/N 0602042174
14	D4367700004	BRACKET, FUEL FILTER	1	
15	0016906020	HEX. HEAD BOLT	2	
16	0016908025	HEX. HEAD BOLT	2	
17	0199900220	SUCTION HOSE.....	1.....	S/N 5686618 AND BELOW
17	0370600220	SUCTION HOSE.....	1.....	S/N 5686619 AND ABOVE
18	0199900800	SUCTION HOSE.....	1.....	S/N 5686618 AND BELOW
18	0370600800	SUCTION HOSE.....	1.....	S/N 5686619 AND ABOVE
19	0199700450	RETURN HOSE.....	1.....	S/N 5686618 AND BELOW
19	0370700450	RETURN HOSE.....	1.....	S/N 5686619 AND ABOVE
20	0199700230	RETURN HOSE.....	1.....	S/N 5686618 AND BELOW
20	0370700230	RETURN HOSE.....	1.....	S/N 5686619 AND ABOVE
21	0605515094	HOSE BAND	4	
22	0605515093	HOSE BAND.....	4.....	S/N 5686618 AND BELOW
22	0605515200	HOSE BAND.....	4.....	S/N 5686619 AND ABOVE

# ENCLOSURE ASSY.

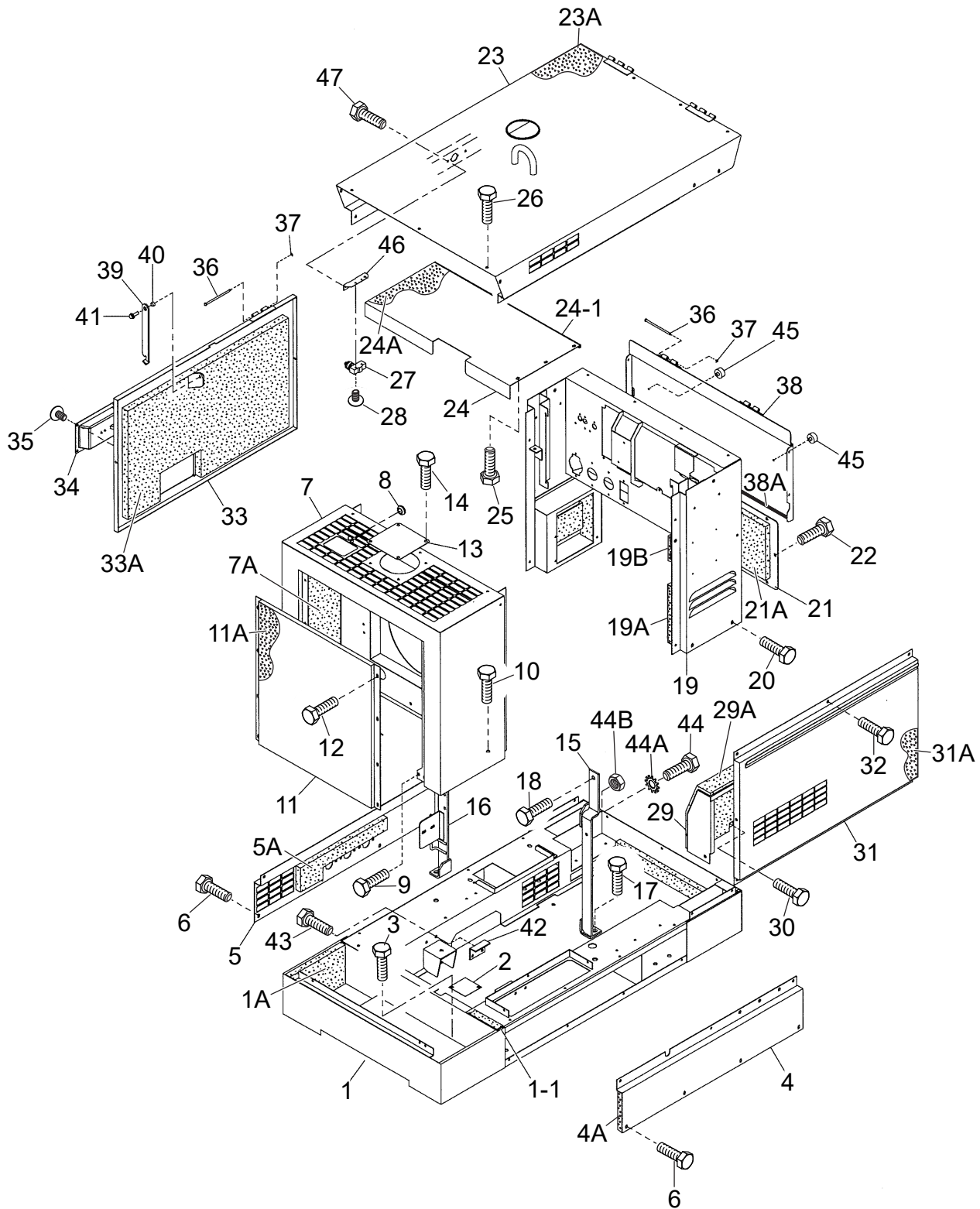

## ENCLOSURE ASSY.

<u>NO.</u>	<u>PART NO.</u>	<u>PART NAME</u>	<u>QTY.</u>	<u>REMARKS</u>
1	D2414000102	BASE	1	
1A	D2494000003	LINING	1	
1-1	0314900680	RUBBER SEAL	1	
2	D3414800104	FLOOR PANEL	1	
3	0016906015	HEX. HEAD BOLT	2	
4	D4414300803-1	SPLASHER PANEL .....	1	REPLACES P/N D4414300803
4A	D2490100004B	LINING .....	1	REPLACES P/N D2490100004
5	D2414300003	SPLASHER PANEL	1	
5A	D2490100004B	LINING .....	1	REPLACES P/N D2490100004
6	0016906015	HEX. HEAD BOLT	16	
7	D4424000702	FRONT FRAME	1	
7A	D4494100503	LINING	1	
8	0601850239	GROMMET	1	
9	0016906015	HEX. HEAD BOLT	2	
10	0016908020	HEX. HEAD BOLT	2	
11	D2424200003	COVER, FRONT FRAME	1	
11A	D4494301004	LINING	1	
12	0016906015	HEX. HEAD BOLT	8	
13	D4425200804	COVER, RADIATOR CAP	1	
14	0016906015	HEX. HEAD BOLT	4	
15	D2434300103	HANGER	1	
16	D2434300003	HANGER	1	
17	0012312030	HEX. HEAD BOLT	2	
18	0012312030	HEX. HEAD BOLT	2	
19	D2444000202	REAR FRAME	1	
19A	D2494300004	LINING	1	
19B	D2491400004	RUBBER SEAL	2	
20	0016906015	HEX. HEAD BOLT	4	
21	D2444300004	COVER, REAR FRAME	1	
21A	D2494300104	LINING	1	
22	0016906015	HEX. HEAD BOLT	8	
23	D2464000102	ROOF PANEL .....	1	S/N 5895125 AND BELOW
23	D2464001602	ROOF PANEL .....	1	S/N 5895126 AND ABOVE
23A	D2494500103	LINING	1	
24	D4464400104	PANEL	1	
24A	D2494500103	LINING	1	
24-1	0314900620	RUBBER SEAL	1	

# ENCLOSURE ASSY. (CONT'D.)

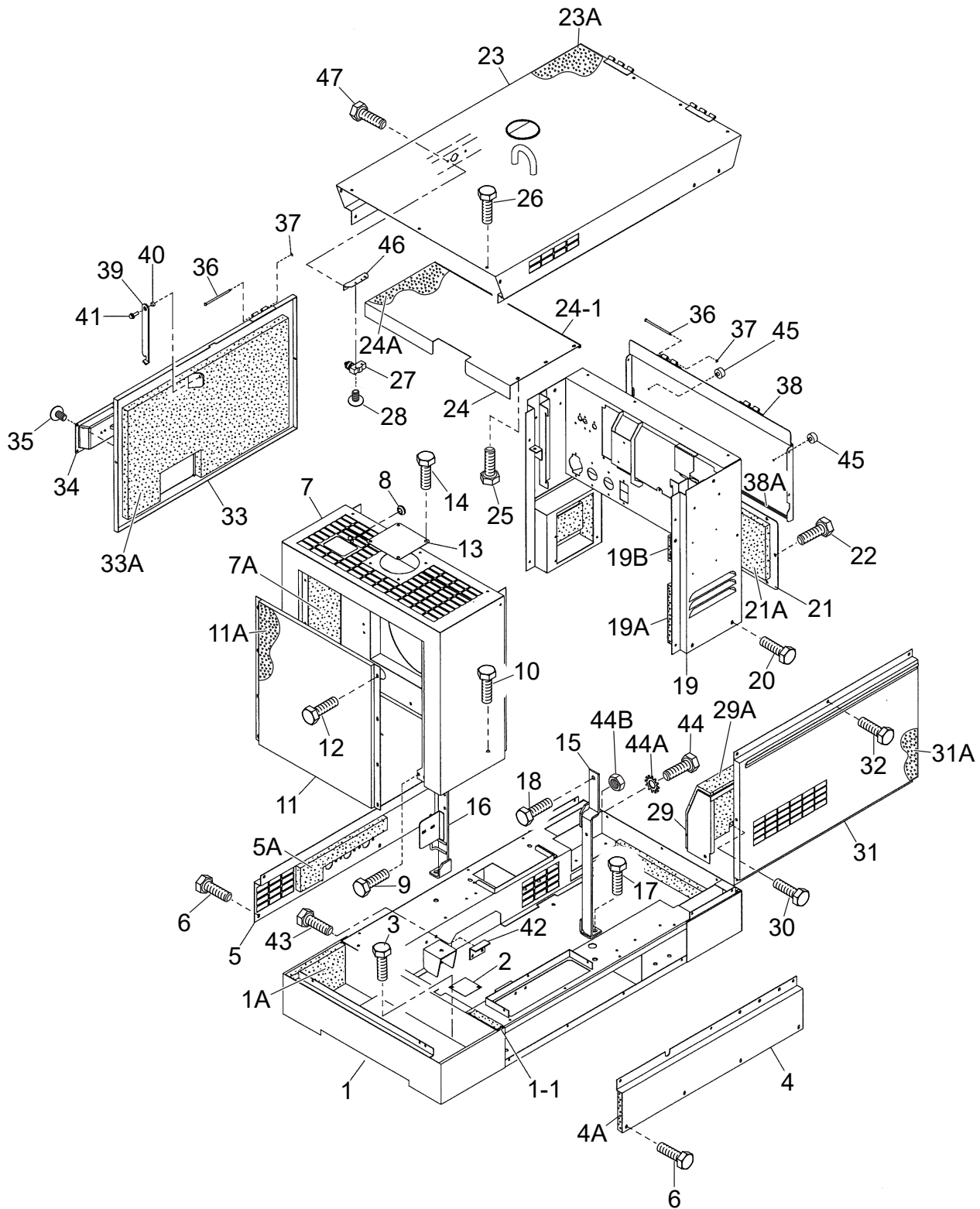

## ENCLOSURE ASSY. (CONT'D.)

<u>NO.</u>	<u>PART NO.</u>	<u>PART NAME</u>	<u>QTY.</u>	<u>REMARKS</u>
25	0016906015	HEX. HEAD BOLT	6	
26	0016906015	HEX. HEAD BOLT	13	
27	Y0601830347	LIMIT SWITCH.....	1.....	S/N 5895125 AND BELOW
27	Y0601830361	LIMIT SWITCH.....	1.....	S/N 5895126 AND ABOVE
28	0027104030	MACHINE SCREW	2	
29	D4454300403	DUCT	1	
29A	D4494401403	LINING	1	
30	0016906015	HEX. HEAD BOLT	3	
31	D4454100203	SIDE PANEL	1	
31A	D4494401304	LINING	1	
32	0016906015	HEX. HEAD BOLT	6	
33	D2454000103	SIDE DOOR.....	1.....	S/N 5895125 AND BELOW
33	D2454000903	SIDE DOOR.....	1.....	S/N 5895126 AND ABOVE
33A	D2494400004	LINING	1	
34	B9114000002	DOOR HANDLE ASSY., BLK.	1	
35	0021806015	MACHINE SCREW	4	
36	0810014704	PIN	4	
37	0080200004	SNAP RING	4	
38	D2444200003	DOOR, REAR FRAME	1	
38A	0226900685	RUBBER SEAL	1	
39	D4454700304	DOOR STAY	1	
40	7835088004	COLLAR	1	
41	0017108020	HEX. HEAD BOLT	1	
42	D4304200604	STOPPER	2	
43	0016908020	HEX. HEAD BOLT	4	
44	0019208015	HEX. HEAD BOLT	1	
44A	0040508000	TOOTHED WASHER	1	
44B	0016908015	HEX. HEAD BOLT	1	
45	0601851613	STOPPER	2	
46	D5261602704	BRACKET, DOOR SWITCH .....	1.....	S/N 5895126 AND ABOVE
47	0017105015	HEX. HEAD BOLT.....	2.....	S/N 5895126 AND ABOVE

# RUBBER SEALS ASSY.

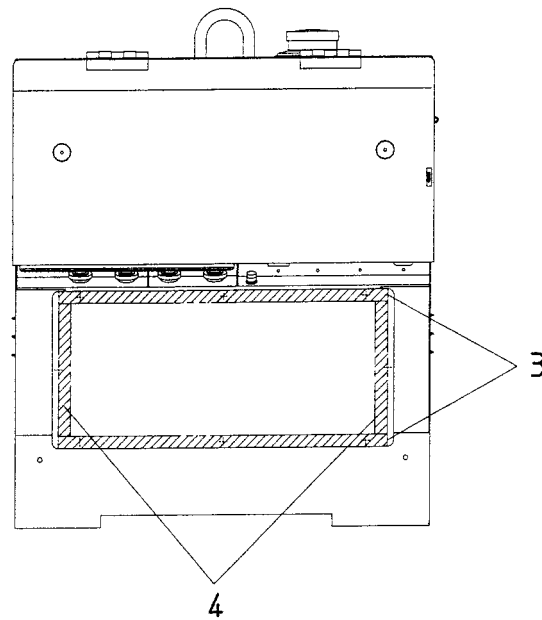
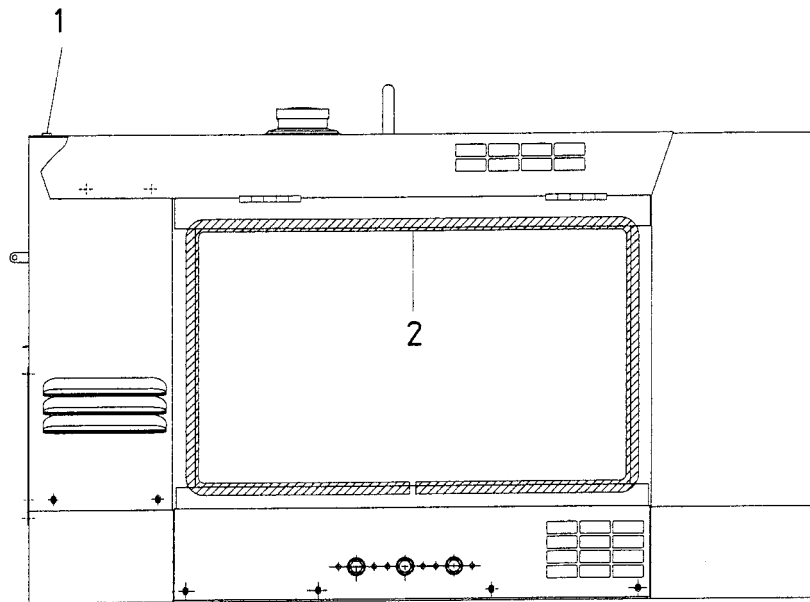



## **RUBBER SEALS ASSY.**

---

<u>NO.</u>	<u>PART NO.</u>	<u>PART NAME</u>	<u>QTY.</u>	<u>REMARKS</u>
1	0314900680	RUBBER SEAL	1	
2	0314602280	RUBBER SEAL	1	
3	0228300540	RUBBER SEAL	2	
4	0228300215	RUBBER SEAL	2	

# NAMEPLATE AND DECALS ASSY.

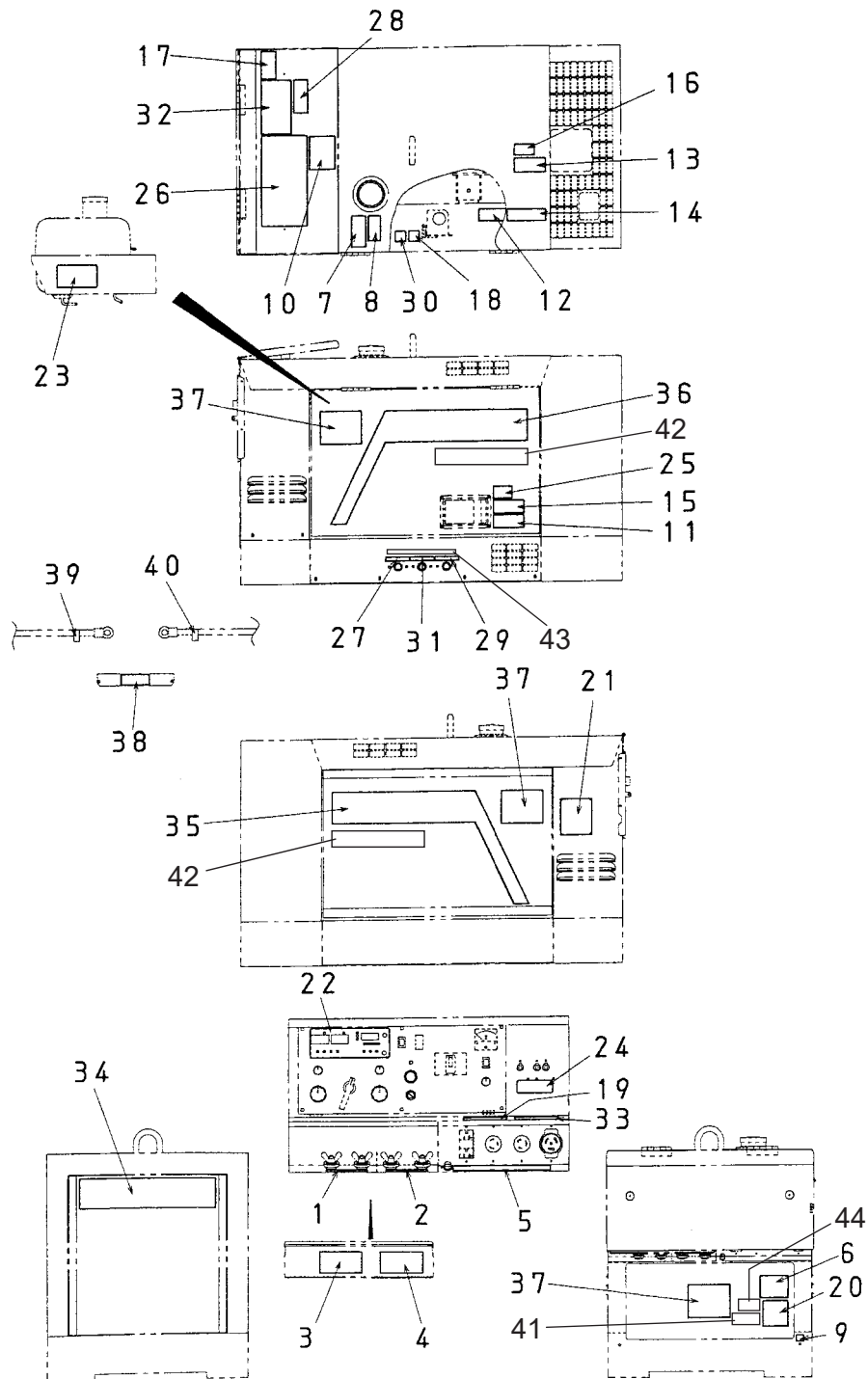

## NAMEPLATE AND DECALS ASSY.

<u>NO.</u>	<u>PART NO.</u>	<u>PART NAME</u>	<u>QTY.</u>	<u>REMARKS</u>
1	D5551001904	DECAL; A WELDING OUTPUT TERMINAL .....	1.....	D55100190
2	D5551002004	DECAL; B WELDING OUTPUT TERMINAL .....	1.....	D55100200
3	D5551002104	DECAL; A WELDING OUTPUT TERMINAL .....	1.....	D55100210
4	D5551002204	DECAL; B WELDING OUTPUT TERMINAL .....	1.....	D55100220
5	D4551002603	DECAL; OUTPUT TERMINAL .....	1.....	D45100260
6	A9504000014	DECAL; WARNING, DANGEROUS GAS .....	1.....	A90400001
7	B9504500004	DECAL; WARNING FIRE.....	1.....	B90450000
8	B9504501204	DECAL; DIESEL FUEL .....	1.....	A90450120
				S/N 5674442 AND BELOW
8	B9504501214	DECAL; DIESEL FUEL .....	1.....	B90450121
				S/N 5674443 AND ABOVE
9	0800628504	DECAL; GROUND .....	1.....	S-1123
10	6390671104	DECAL; IMPORTANT "CHECK DAILY" .....	1.....	S-2377
11	B9504000404	DECAL; MOVING PARTS.....	1.....	B90400040
12	8700611524	DECAL; WARNING DIESEL OIL .....	1.....	S-4926B
13	B9504100104	DECAL; WARNING RADIATOR CAP .....	1.....	B90410010
14	W8700611804	DECAL; DANGER AGAINST EXHAUST GAS...1.....		S-4984
15	B9504000304	DECAL; CAUTION HOT PARTS.....	1.....	B90400030
16	W7810680204	DECAL; COOLING WATER.....	1.....	S-3061
17	0820610404	DECAL; CAUTION.....	1.....	S-3627
18	1980680004	DECAL; FUEL COCK.....	1.....	S-3704
19	8700611904	DECAL; DANGER ELECTRICAL SHOCK.....1.....		S-4985
20	B9531100004	DECAL; DANGER (GROUND) .....	1.....	D93110000
21	D2531100604	DECAL; SPECIFICATION.....	1.....	D23110060A
22	D2551000603	DECAL; OPERATION INDICATION	1	
23	D2551001004	DECAL; ERROR LOAD .....	1.....	D25100100
24	D2551000804	DECAL; AC CIRCUIT PROTECTOR .....	1.....	D25100080
25	1630610504	DECAL; CAUTION DOOR.....	1.....	S-1409
26	D2551000703	DECAL; OPERATING PROCEDURE .....	1.....	D25100070A
				S/N 5844497 AND BELOW
26	D2551000713	DECAL; OPERATING PROCEDURE .....	1.....	D25100071
				S/N 5844498 AND ABOVE
27	7810680104	DECAL; FUEL DRAIN.....	1.....	S-3060
				S/N 5797110 AND BELOW
28	DCL160	DECAL; PROPOSITION 65 WARNING.....1.....		D92210020
				REPLACES P/N D9522100204
				S/N 5825318 AND BELOW
29	1630645004	DECAL; OIL DRAIN .....	1.....	S-1403
				S/N 5797110 AND BELOW
30	1630610404	DECAL; CAUTION FUEL FILTER.....	1.....	S-1406
31	1630647004	DECAL; WATER DRAIN .....	1.....	S-1404
				S/N 5797110 AND BELOW

# NAMEPLATE AND DECALS ASSY. (CONT'D.)

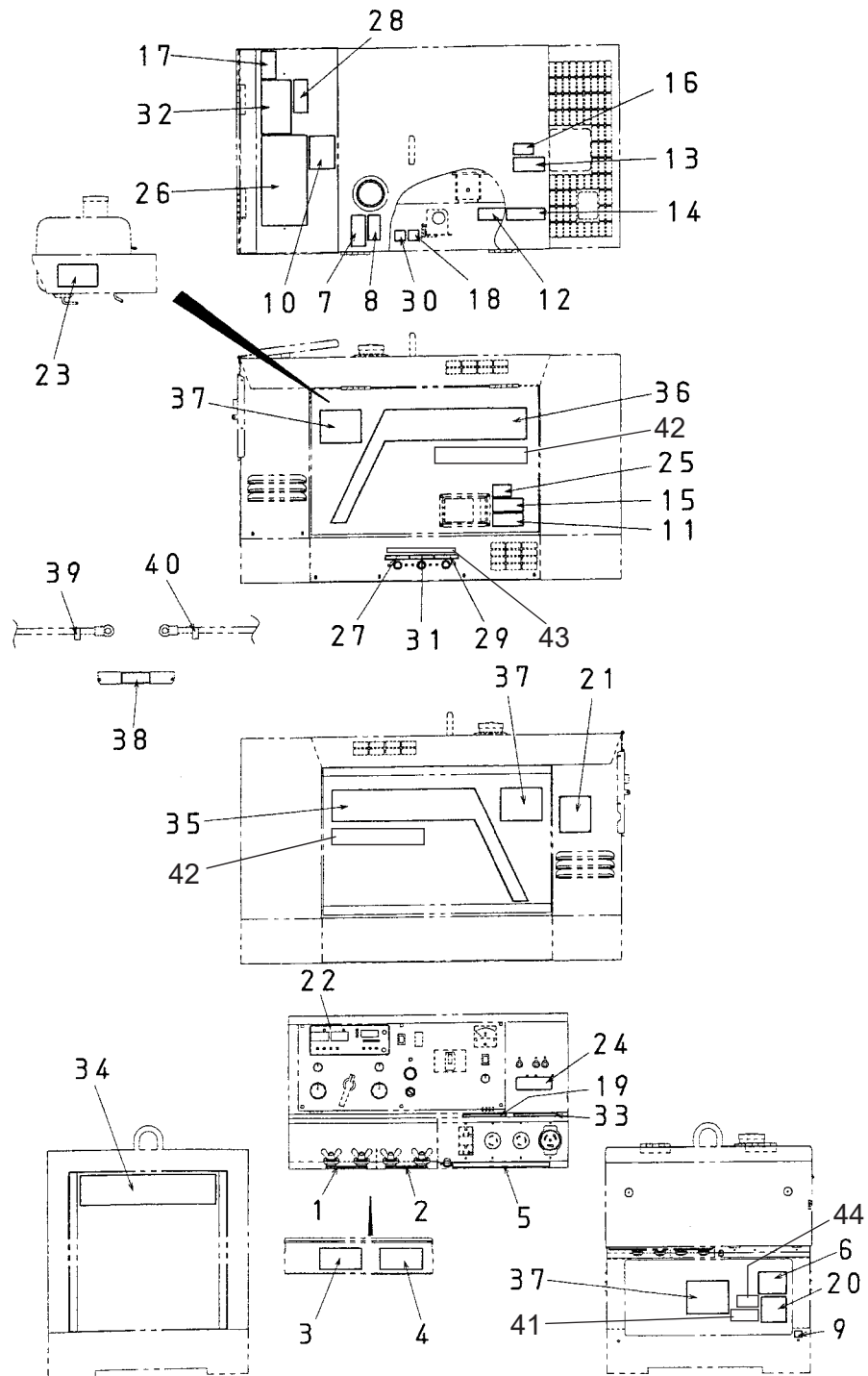

## NAMEPLATE AND DECALS ASSY. (CONT'D.)

<u>NO.</u>	<u>PART NO.</u>	<u>PART NAME</u>	<u>QTY.</u>	<u>REMARKS</u>
32	D9512100203	DECAL; WARNING LEVEL.....	1.....	D91210020A
33	9511100304	DECAL; WARNING.....	1.....	D91110030
34	D2551000902	DECAL; FRONT STICKER	1	
35	D4561100303	DECAL; STRIPE	1	
36	D4561100403	DECAL; STRIPE	1	
37	D3561000104	DECAL; MQ	3	
38	0820650604	DECAL; CAUTION BATTERY	1	
39	0800689404	DECAL; + .....	1.....	S-2090
40	0800689504	DECAL; - .....	1.....	S-2091
41	920214100	DECAL; WARNING, START FIRES.....	1.....	M90420000 REPLACES P/N M9504200004 S/N 5674443 AND ABOVE
42	D9511200503	DECAL; SMART STICK.....	2.....	S/N 5674443 TO 5812025
42	D9511200803	DECAL; SMART STICK.....	2.....	S/N 5812026 AND ABOVE
43	D5551007704	DECAL; DRAIN.....	1.....	D55100770 S/N 5797111 AND ABOVE
44	D9511101304	DECAL; WARNING, PROPOSITION 65.....	1.....	A91110130 S/N 5825319 AND ABOVE

# PARTS MANUAL

## HERE'S HOW TO GET HELP

PLEASE HAVE THE MODEL AND SERIAL  
NUMBER ON-HAND WHEN CALLING

### United States

#### ***Multiquip Inc.***

(310) 537- 3700  
6141 Katella Avenue Suite 200  
Cypress, CA 90630  
E-MAIL: [mq@multiquip.com](mailto:mq@multiquip.com)  
WEBSITE: [www.multiquip.com](http://www.multiquip.com)

---

### Canada

#### ***Multiquip***

(450) 625-2244  
4110 Industriel Boul.  
Laval, Quebec, Canada H7L 6V3  
E-MAIL: [infocanada@multiquip.com](mailto:infocanada@multiquip.com)

### United Kingdom

#### ***Multiquip (UK) Limited Head Office***

0161 339 2223  
Unit 2, Northpoint Industrial Estate, Globe Lane,  
Dukinfield, Cheshire SK16 4UJ  
E-MAIL: [sales@multiquip.co.uk](mailto:sales@multiquip.co.uk)

© COPYRIGHT 2023, MULTIQUIP INC.

Multiquip Inc, the MQ logo are registered trademarks of Multiquip Inc. and may not be used, reproduced, or altered without written permission. All other trademarks are the property of their respective owners and used with permission.

This manual MUST accompany the equipment at all times. This manual is considered a permanent part of the equipment and should remain with the unit if resold.

The information and specifications included in this publication were in effect at the time of approval for printing. Illustrations, descriptions, references and technical data contained in this manual are for guidance only and may not be considered as binding. Multiquip Inc. reserves the right to discontinue or change specifications, design or the information published in this publication at any time without notice and without incurring any obligations.

