

PARTS MANUAL



MODELS

DLW-400ESA4/DLW-400ESA4F WELDER/GENERATOR (KUBOTA D902-E4B DIESEL ENGINE)

REF. NO.

D5844301574B - DLW-400ESA4

D5844302624 - DLW-400ESA4F

Revision #11 (06/18/26)

To find the latest revision of this publication or associated operation manual, visit our website at: www.multiquip.com



TABLE OF CONTENTS

DLW400ESA4/ESA4F Welder-Generator

Explanation of Code in Remarks Column..... 4
Suggested Spare Parts 5

Component Drawings

Generator Assembly 6–7
Control Panel, Upper Assembly.....8–11
Control Panel, Lower Assembly..... 12–13
Electric Parts 1 Assembly 14–17
Electric Parts 2 Assembly 18–21
Engine and Radiator Assembly 22–23
Battery Assembly 24–25
Muffler Assembly 26–27
Fuel Tank Assembly..... 28–31
Enclosure Assembly 32–35
Rubber Seals Assembly 36–37
DLW400ESA4 Nameplate and Decals Assy.... 38–41
DLW400ESA4F Nameplate and Decals Assy.. 42–43

NOTICE

Specifications and part numbers are subject to change without notice.

EXPLANATION OF CODE IN REMARKS COLUMN

The following section explains the different symbols and remarks used in the Parts section of this manual. Use the help numbers found on the back page of the manual if there are any questions.

NOTICE

The contents and part numbers listed in the parts section are subject to change without notice. Multiquip does not guarantee the availability of the parts listed.

SAMPLE PARTS LIST

NO.	PART NO.	PART NAME	QTY.	REMARKS
1	12345	BOLT	1	INCLUDES ITEMS W/%
2%		WASHER, 1/4 IN.		NOT SOLD SEPARATELY
2%	12347	WASHER, 3/8 IN. ...	1	MQ-45T ONLY
3	12348	HOSE	A/R	MAKE LOCALLY
4	12349	BEARING	1	S/N 2345B AND ABOVE

NO. Column

Unique Symbols — All items with same unique symbol (@, #, +, %, or >) in the number column belong to the same assembly or kit, which is indicated by a note in the “Remarks” column.

Duplicate Item Numbers — Duplicate numbers indicate multiple part numbers, which are in effect for the same general item, such as different size saw blade guards in use or a part that has been updated on newer versions of the same machine.

NOTICE

When ordering a part that has more than one item number listed, check the remarks column for help in determining the proper part to order.

PART NO. Column

Numbers Used — Part numbers can be indicated by a number, a blank entry, or TBD.

TBD (To Be Determined) is generally used to show a part that has not been assigned a formal part number at the time of publication.

A blank entry generally indicates that the item is not sold separately or is not sold by Multiquip. Other entries will be clarified in the “Remarks” Column.

QTY. Column

Numbers Used — Item quantity can be indicated by a number, a blank entry, or A/R.

A/R (As Required) is generally used for hoses or other parts that are sold in bulk and cut to length.

A blank entry generally indicates that the item is not sold separately. Other entries will be clarified in the “Remarks” Column.

REMARKS Column

Some of the most common notes found in the “Remarks” Column are listed below. Other additional notes needed to describe the item can also be shown.

Assembly/Kit — All items on the parts list with the same unique symbol will be included when this item is purchased.

Indicated by:

“INCLUDES ITEMS W/(unique symbol)”

Serial Number Break — Used to list an effective serial number range where a particular part is used.

Indicated by:

“S/N XXXXX AND BELOW”

“S/N XXXX AND ABOVE”

“S/N XXXX TO S/N XXX”

Specific Model Number Use — Indicates that the part is used only with the specific model number or model number variant listed. It can also be used to show a part is NOT used on a specific model or model number variant.

Indicated by:

“XXXXX ONLY”

“NOT USED ON XXXX”

“Make/Obtain Locally” — Indicates that the part can be purchased at any hardware shop or made out of available items. Examples include battery cables, shims, and certain washers and nuts.

“Not Sold Separately” — Indicates that an item cannot be purchased as a separate item and is either part of an assembly/kit that can be purchased, or is not available for sale through Multiquip.

SUGGESTED SPARE PARTS

DLW400ESA4 WELDER GENERATOR

1 to 3 units

Qty.	P/N	Description
1	D5311501104	HOSE, RADIATOR UPPER
1	D5311501203	HOSE, RADIATOR LOWER
1	0602011079	CAP, RADIATOR
1	A9924800024	CAP, FUEL TANK
6	0810105900	FILTER, FUEL
6	1552143160	FILTER, FUEL ELEMENT
1	1747297011	FAN BELT
1	Y0601806433	CIRCUIT BREAKER, 2P 20A
1	0601806424	CIRCUIT BREAKER, 1P 30A
1	0601806425	CIRCUIT BREAKER, 2P 30A
1	0601820664	AUTOMATIC VOLTAGE REG.
1	0601840219	RHEOSTAT (CUR/VOLT. REG.)
1	0601840103	KNOB, RHEOSTAT
1	0601840095	RHEOSTAT (WELD. REG.)
1	0601840100	KNOB, RHEOSTAT
1	0601840095	RHEOSTAT (TIME. REG.)
1	0601840170	KNOB, RHEOSTAT TIME REG.
5	0601806681	FUSE, 5A
5	0601806643	FUSE, 15A
5	Y0601806646	FUSE, 20A
5	0601806640	FUSE, 65A

NOTICE

Part numbers on this Suggested Spare Parts list may supersede/replace the part numbers shown in the following parts lists.

KUBOTA D902-E4B DIESEL ENGINE

1 to 3 units

Qty.	P/N	Description
5	HH15032430	CARTRIDGE, OIL FILTER
3	0602046391	FILTER, AIR ELEMENT
1	1584139010	SWITCH, OIL
4	1685165512	GLOW PLUG
2	1753883040	SWITCH, THERMO.

GENERATOR ASSY.

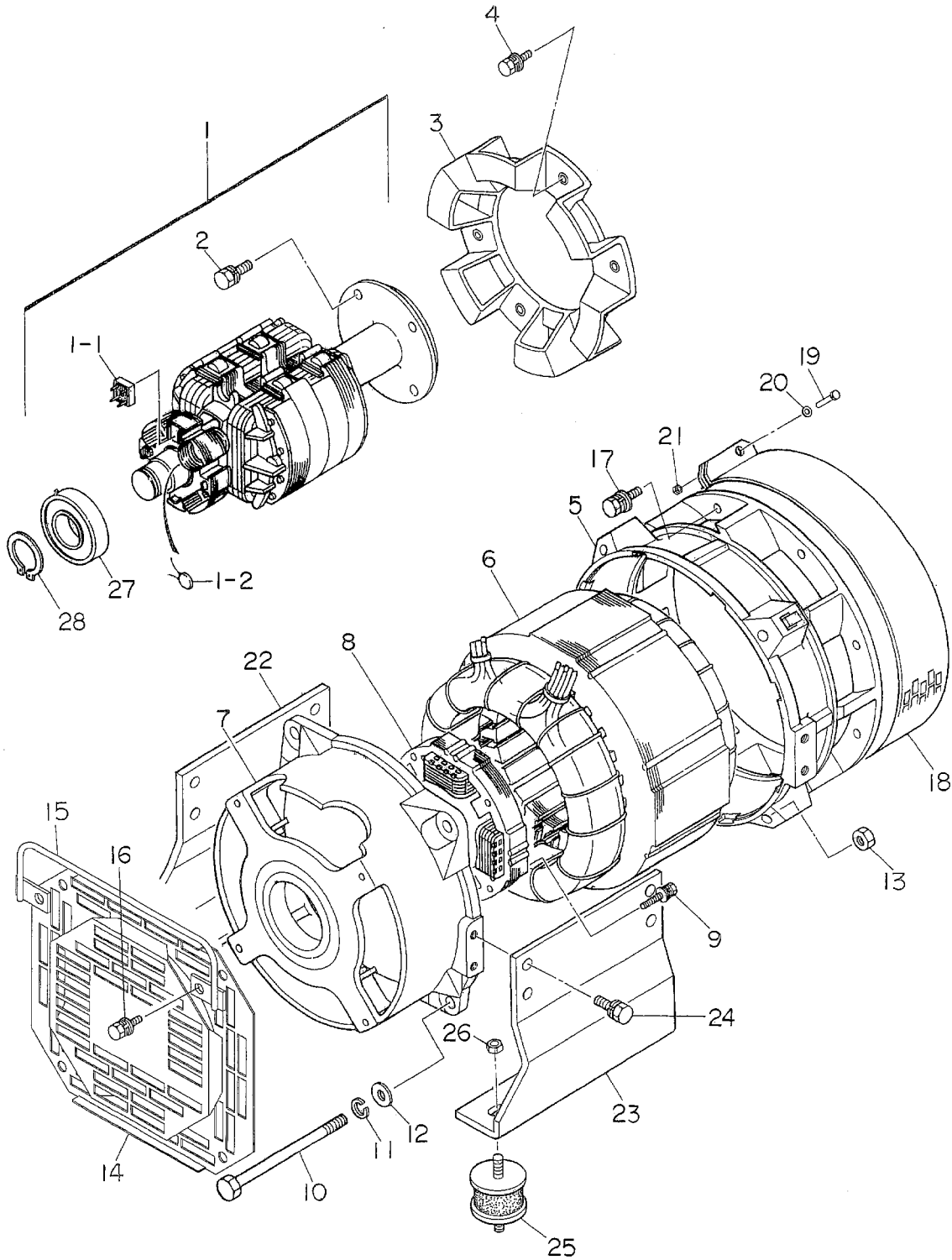

GENERATOR ASSY.

<u>NO.</u>	<u>PART NO.</u>	<u>PART NAME</u>	<u>QTY.</u>	<u>REMARKS</u>
1	D4110000403	ROTOR ASSY.....	1.....	INCLUDES ITEMS W/\$
1-1\$	0601820037	RECTIFIER	1	
1-2\$	0601822638	SURGE ABSORBER, TNR15G 431K.....	1.....	S/N 5851446 AND BELOW DLW400ESA4
1-2\$	0601822692	SURGE ABSORBER, TND14V 431K.....	1.....	S/N 5851447 AND ABOVE DLW400ESA4
1-2\$	0601822692	SURGE ABSORBER, TND14V 431K.....	1.....	DLW400ESA4F
2	0012410030	HEX. HEAD BOLT	4	
3	D4111100103	FAN	1	
4	011208025	HEX. HEAD BOLT.....	6.....	REPLACES P/N 0017108025
5	D4153100102	END BRACKET	1	
6	D5135001603	ARMATURE ASSY.	1	
7	D4153000202A	END BRACKET.....	1.....	REPLACES P/N D4153000202
8	D4139000003	FIELD ASSY., EXCITER	1	
9	0017105035	HEX. HEAD BOLT	4	
10	D4131500004	SET BOLT	4	
11	0040012000	WASHER, LOCK	4	
12	031112230	WASHER, FLAT.....	4.....	REPLACES P/N 0041212000
13	0030012000	HEX. NUT	4	
14	D5154400003	COVER	1	
15	D4185300004	BRACKET	1	
16	0017108035	HEX. HEAD BOLT.....	4.....	DLW400ESA4
16	011008020	HEX. HEAD BOLT.....	4.....	REPLACES P/N 0017108020 DLW400ESA4F
17	0012410025	HEX. HEAD BOLT	8	
18	D4155400204	COVER, FAN	1	
19	0340406040	HEX. HEAD BOLT	1	
20	0041206000	WASHER, FLAT.....	1.....	DLW400ESA4F
21	020106050	HEX. NUT.....	1.....	REPLACES P/N 0037906000
22	D5132100303	GENERATOR FOOT	1	
23	D5132100203	GENERATOR FOOT	1	
24	012210025	HEX. HEAD BOLT.....	8.....	REPLACES P/N 0012310025
25	7605419004A	RUBBER SUSPENSION.....	2.....	REPLACES P/N 7605419004
26	021112140	HEX. NUT.....	2.....	REPLACES P/N 0207010000
27	0071206307	BEARING	1	
28	0080000035	SNAP RING	1	

CONTROL PANEL, UPPER ASSY.

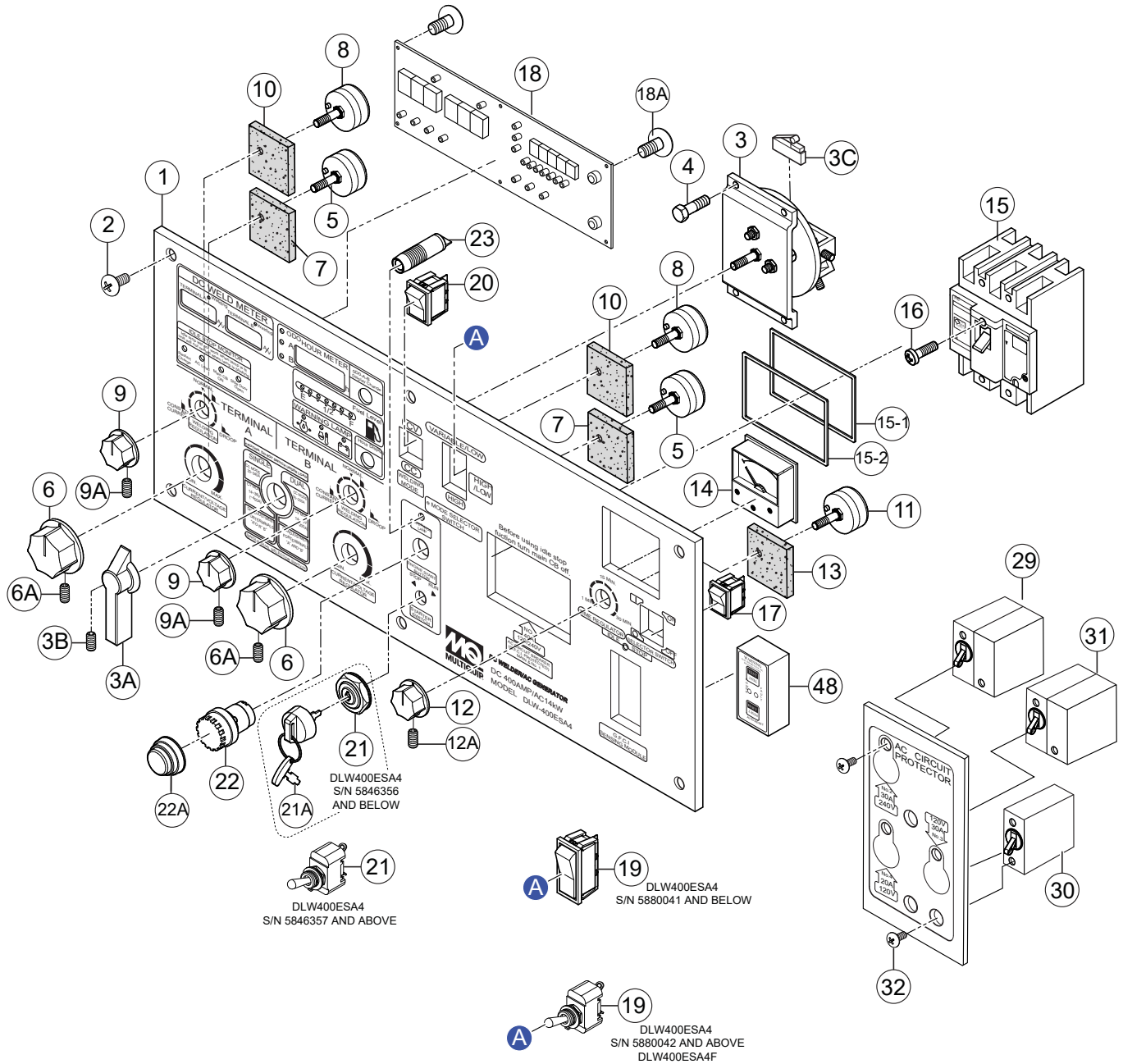

CONTROL PANEL, UPPER ASSY.

<u>NO.</u>	<u>PART NO.</u>	<u>PART NAME</u>	<u>QTY.</u>	<u>REMARKS</u>
1	D5511303402	CONTROL PANEL (DLW400ESA4).....	1.....	S/N 5846356 AND BELOW
1	D5511303412	CONTROL PANEL (DLW400ESA4).....	1.....	S/N 5846357 ~ 5880041
1	D5511303422	CONTROL PANEL (DLW400ESA4).....	1.....	S/N 5880042 AND ABOVE
1	D5511306202	CONTROL PANEL (DLW400ESA4F).....	1.....	S/N 50019183 AND BELOW
1	D5511306212	CONTROL PANEL (DLW400ESA4F).....	1.....	S/N 50019184 AND ABOVE
2	0021506030	MACHINE SCREW.....	6.....	REPLACES P/N 0021806030
3	0601803075	SELECTOR SWITCH	1.....	INCLUDES ITEMS W/#
3A#	0601803116	HANDLE	1	
3B#	0025104018	SET SCREW	1	
3C#	0601830014	MICROSWITCH	1	
4	011106015	HEX. HEAD BOLT.....	4.....	REPLACES P/N 0017106015
5	Y0601840219	RHEOSTAT (CURRENT/VOLT. REG.), 500W	2	
6	0601840103	KNOB	2	
6A	0023304008	SET SCREW	4	
7	0801883003	INSULATOR	2	
8	0601840095	RHEOSTAT (WELDING REG.), 2KW	2	
9	0601840100	KNOB	2	
9A	0023304008	SET SCREW.....	4.....	REPLACES P/N 0023303508
10	0801883003	INSULATOR	2	
11	0601840095	RHEOSTAT (TIME REG.), 2KW	1	
12	0601840170	KNOB	1	
12A	0023304008	SET SCREW.....	1.....	REPLACES P/N 0023303508
13	0801883003	INSULATOR	1	
14	0601800281	AC VOLTMETER, 5A 0-150/300V	1	
15	0601806438	CIRCUIT BREAKER	1	
15-1	0317900080	RUBBER SEAL	2	
15-2	D5491400204	RUBBER SEAL	1	
16	Y0027504055	MACHINE SCREW	2	
17	0601831600	SWITCH, IDLE STOP SELECTOR	1	
18	D5266200104	DIGITAL PANEL	1	
18A	0027103005	MACHINE SCREW	6	
19	Y0601831605	SWITCH, E MODE SELECTOR	1.....	S/N 5880041 AND BELOW DLW400ESA4
19	Y0601831379	SWITCH, E MODE SELECTOR	1.....	S/N 5880042 AND ABOVE DLW400ESA4
19	Y0601831379	SWITCH, E MODE SELECTOR	1.....	S/N 50019183 AND BELOW DLW400ESA4F
19	Y0601831605	SWITCH, E MODE SELECTOR	1.....	S/N 50019184 AND ABOVE DLW400ESA4F
20	0601831600	SWITCH, WELDING MODE SELECTOR	1	
21	0602100310	STARTER SWITCH (DLW400ESA4).....	1.....	S/N 5846356 AND BELOW
21	0601830731	STARTER SWITCH (DLW400ESA4).....	1.....	S/N 5846357 AND ABOVE
21	0601830731	STARTER SWITCH (DLW400ESA4F)	1	
21A	0602100240	KEY (DLW400ESA4).....	1.....	S/N 5846356 AND BELOW

CONTROL PANEL, UPPER ASSY. (CONT'D.)

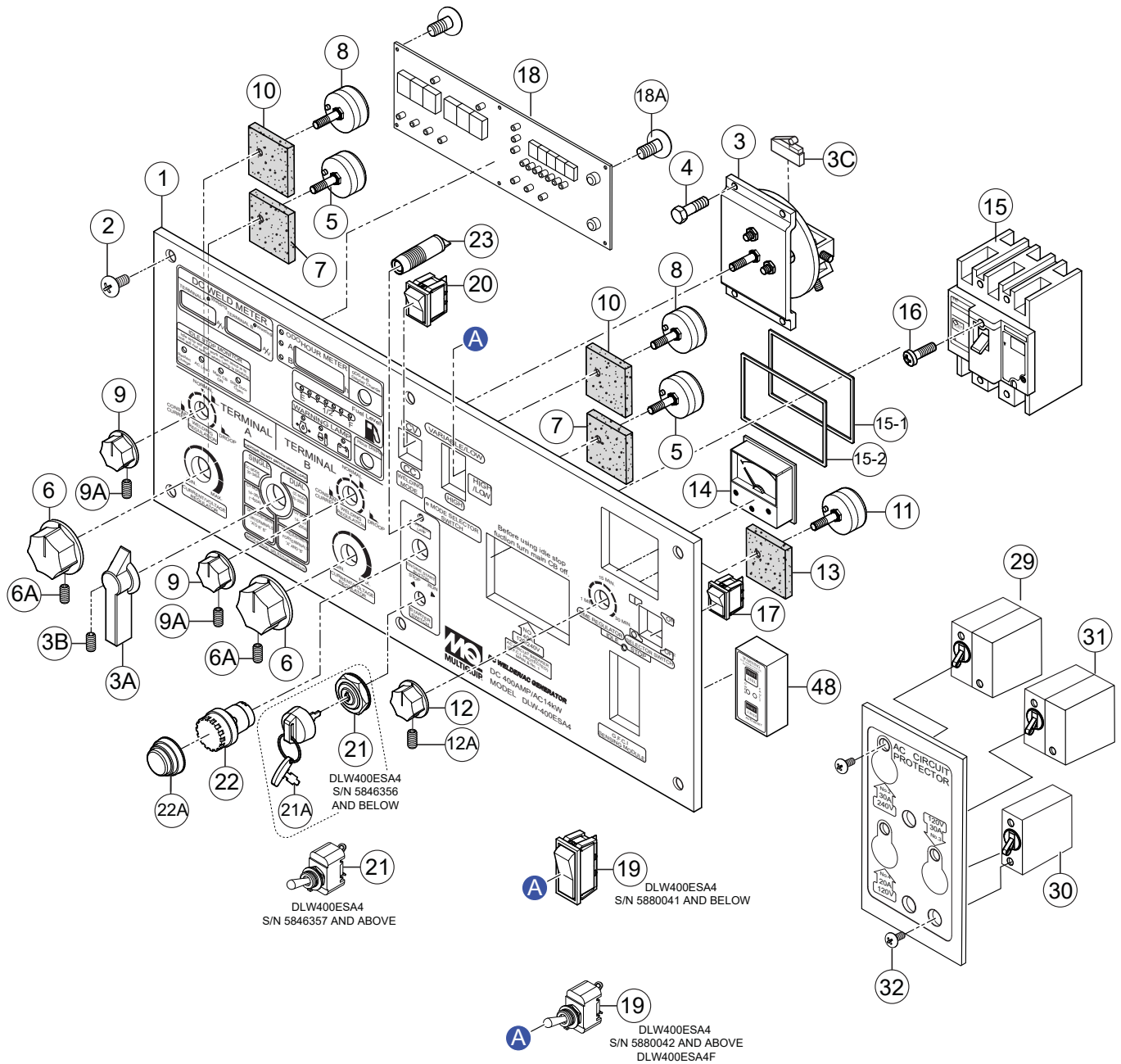

CONTROL PANEL, UPPER ASSY. (CONT'D.)

<u>NO.</u>	<u>PART NO.</u>	<u>PART NAME</u>	<u>QTY.</u>	<u>REMARKS</u>
22	0601831966	ENGINE START BUTTON	1	
22A	0601832048	CAP	1	
23	Y0601814114	LAMP (DLW400ESA4).....	1	S/N 5870216 AND BELOW
23	Y0601816708	LAMP (DLW400ESA4).....	1	S/N 5870217 AND ABOVE
23	Y0601816708	LAMP (DLW400ESA4F)	1	
29	0601806425	CIRCUIT BREAKER, CP32EN, 2P 30A.....	1	S/N 50002260 AND BELOW DLW400ESA4
29	0601873324	CIRCUIT BREAKER, 2P 30A.....	1	S/N 50002261 AND ABOVE DLW400ESA4
29	0601873324	CIRCUIT BREAKER, 2P 30A.....	1	DLW400ESA4F
30	0601806424	CIRCUIT BREAKER, CP31EN, 1P 30A.....	1	S/N 50002260 AND BELOW DLW400ESA4
30	0601873323	CIRCUIT BREAKER, 1P, 30A.....	1	S/N 50002261 AND ABOVE DLW400ESA4
30	0601873323	CIRCUIT BREAKER, 1P, 30A.....	1	DLW400ESA4F
31	Y0601806433	CIRCUIT BREAKER, CP32EN, 2P 20A.....	1	S/N 50002260 AND BELOW DLW400ESA4
31	0601873322	CIRCUIT BREAKER, 2P 20A.....	1	S/N 50002261 AND ABOVE DLW400ESA4
31	0601873322	CIRCUIT BREAKER, 2P 20A.....	1	DLW400ESA4F
32	0021003005	MACHINE SCREW	6	
48	0601829301	EARTH LEAKAGE RELAY, 120V.....	1	S/N 5915954 AND BELOW DLW400ESA4
48	0601829302	EARTH LEAKAGE RELAY, 120V.....	1	S/N 5915955 AND ABOVE DLW400ESA4
48	0601829302	EARTH LEAKAGE RELAY, 120V.....	1	S/N 50016638 AND BELOW DLW400ESA4F
48	0601829301	EARTH LEAKAGE RELAY, 120V.....	1	S/N 50016639 AND ABOVE

CONTROL PANEL, LOWER ASSY.

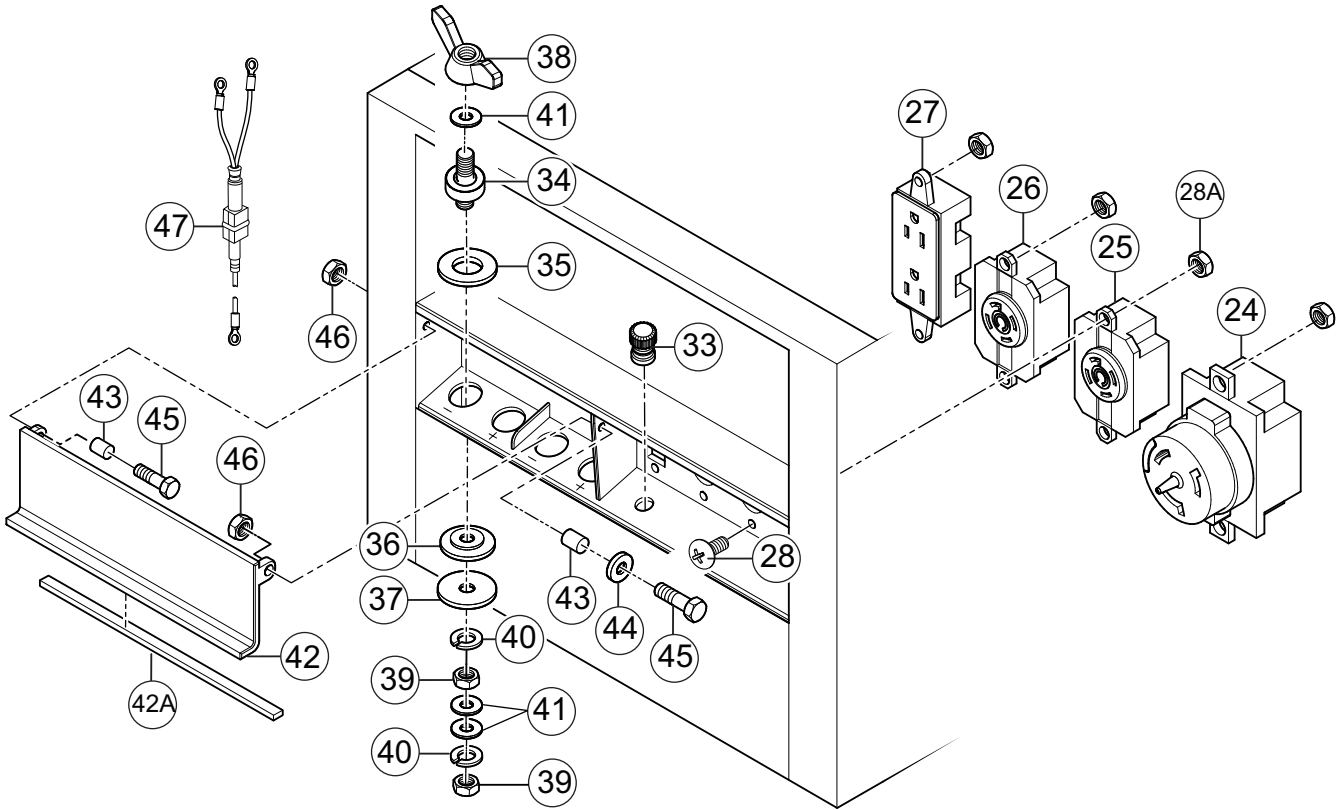

CONTROL PANEL, LOWER ASSY.

<u>NO.</u>	<u>PART NO.</u>	<u>PART NAME</u>	<u>QTY.</u>	<u>REMARKS</u>
24	0601814014	RECEPTACLE, CS-6369L	1	
25	0601811033	RECEPTACLE, L6-30R	1	
26	0601811031	RECEPTACLE, L5-30R	1	REPLACES P/N 0601811035
27	0601814013	RECEPTACLE, 5-20R GF20LA	1	S/N 5792425 AND BELOW DLW400ESA4
27	0601814024	RECEPTACLE, 5-20R GFRST20DEN.....	1	S/N 5792426 ~ 5862066 DLW400ESA4
27	0601814034	RECEPTACLE, 5-20R GFWR2-E	1	S/N 5862067 AND ABOVE DLW400ESA4
27	0601814034	RECEPTACLE, 5-20R GFWR2-E	1	DLW400ESA4F
28	0027104015	MACHINE SCREW	8	
28A	OEMAA8	HEX. NUT	8	REPLACES P/N 0207004000
33	0601815109	GROUND TERMINAL	1	
34	0801888204	OUTPUT TERMINAL, WELDING	4	
35	0801840104	INSULATOR WASHER	4	
36	0801840004	INSULATOR WASHER	4	
37	6109170	SET WASHER, OUTPUT TERMINAL.....	4	REPLACES P/N 0801841204
38	022910220	WING NUT	4	REPLACES P/N 0801884004
39	0039312000	HEX. NUT	8	REPLACES P/N 0039512000
40	0042212000	WASHER, LOCK	8	
41	0041412000	WASHER, FLAT	12	
42	D5237101003	COVER, OUTPUT TERMINAL	1	
42A	D5237400504	RUBBER SHEET	1	
43	0821800014	COLLAR.....	2	REPLACES P/N W0821800014
44	D9311200004	STAY RUBBER	1	
45	011206020	HEX. HEAD BOLT.....	2	REPLACES P/N 0016906020
46	020106050	HEX. NUT	2	REPLACES P/N 0038706000
47	D4268304714	NOISE FILTER	2	

ELECTRIC PARTS 1 ASSY.

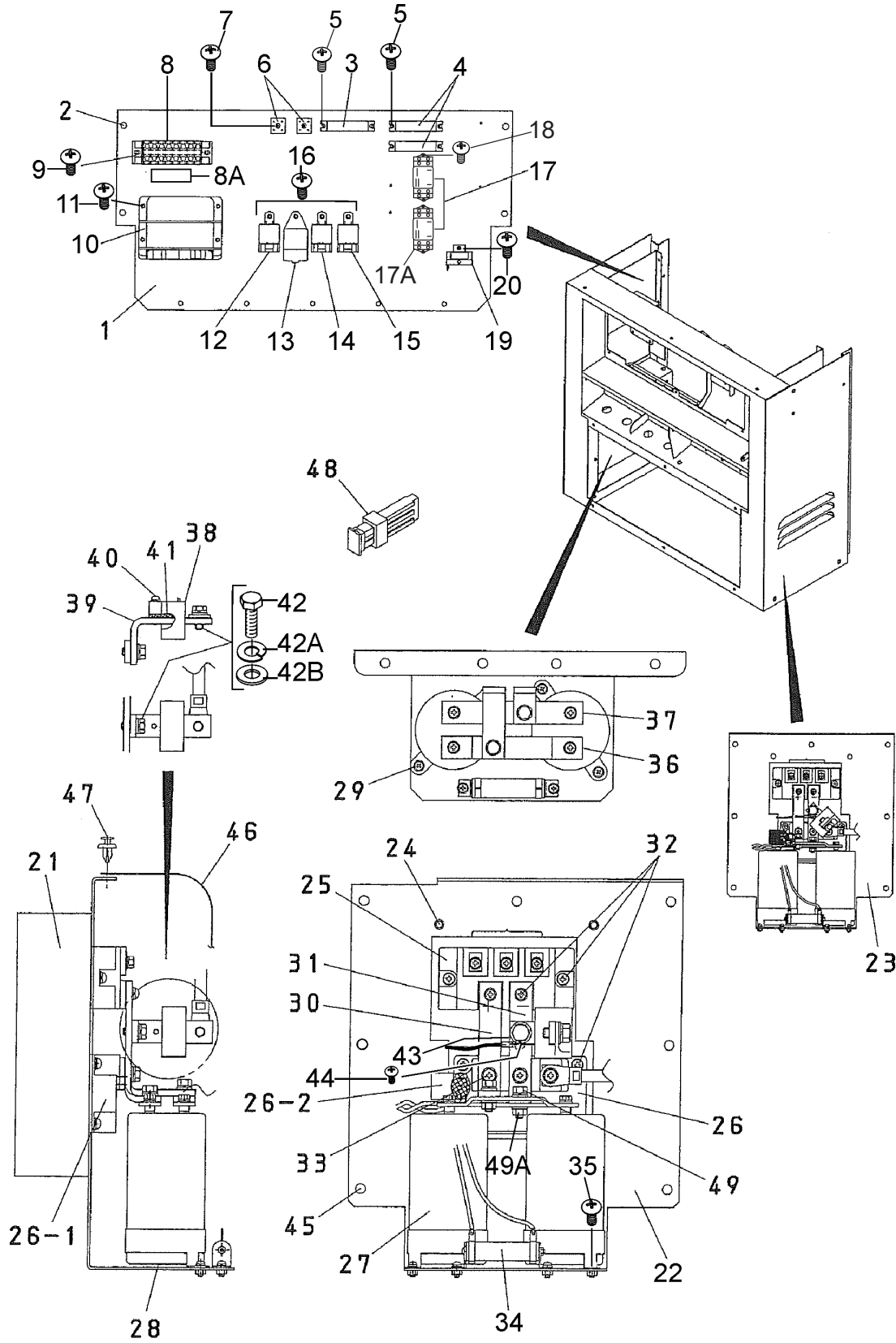

ELECTRIC PARTS 1 ASSY.

<u>NO.</u>	<u>PART NO.</u>	<u>PART NAME</u>	<u>QTY.</u>	<u>REMARKS</u>
1	D5261501903	SET PANEL, ELECTRIC PARTS	1	
2	0016906015	HEX. HEAD BOLT	4	
3	0601842349	RESISTOR, 20W, 35W	1	
4	0601842198	RESISTOR, 20W, 1KW.....	2.....	REPLACES P/N 0601842262
5	0027104015	MACHINE SCREW	6	
6	0601823204	RECTIFIER	2	
7	0027103015	MACHINE SCREW	2	
8	0601815422	TERMINAL BOARD, 8P	1	
8A	D9521000704	DECAL; SYMBOL MARK	1	
9	0027104025	MACHINE SCREW	2	
10	1747260605	EMERGENCY UNIT.....	1.....	REPLACES P/N 0602200475
11	0027105025	MACHINE SCREW	4	
12	6888153542	STARTER RELAY.....	1.....	REPLACES P/N 0602202566
13	5H63242511	GLOW RELAY.....	1.....	REPLACES P/N Y0602202632
14	6888153542	RELAY.....	1.....	REPLACES P/N 0602202566
15	0601823707	RELAY, 1A	1	
16	0027105015	MACHINE SCREW	4	
17	0601820915	RELAY, DC12V (DLW400ESA4).....	1.....	S/N 5734286 AND BELOW
17	0601820901	RELAY, DC12V (DLW400ESA4).....	2.....	S/N 5734287 AND ABOVE
17	0601820901	RELAY, DC12V (DLW400ESA4F)	2	
17A	Y0601823174	SOCKET (DLW400ESA4).....	1.....	S/N 5734286 AND BELOW
18	0027104020	MACHINE SCREW (DLW400ESA4).....	2.....	S/N 5734286 AND BELOW
18	0027104015	MACHINE SCREW (DLW400ESA4).....	4.....	S/N 5734287 AND ABOVE
18	0027104015	MACHINE SCREW (DLW400ESA4F)	4	
19	Y0601804203	DC CURRENT TRANSFORMER	1	
20	0027104015	MACHINE SCREW	1	
21	D5267300704	COOLING FIN	2	
22	D5261601704	BRACKET	1	
23	D5261601604	BRACKET	1	
24	0016906015	HEX. HEAD BOLT	8	
25	0601823256	RECTIFIER	2	
26	D4268000403	IGBT MODULE ASSY.	2.....	INCLUDES ITEMS W/@
26-1@	0601821258	IGBT MODULE	2	
26-2@	D9925800044	IGBT PROTECTIVE UNIT	2	
27	0601826170	CONDENSER, 160V, 10000 μ F	4	
28	D5261800404	INSULATOR RUBBER	4	
29	0027104010	MACHINE SCREW	8	
30	D5267300404	CONNECTION PLATE	2	

ELECTRIC PARTS 1 ASSY. (CONT'D.)

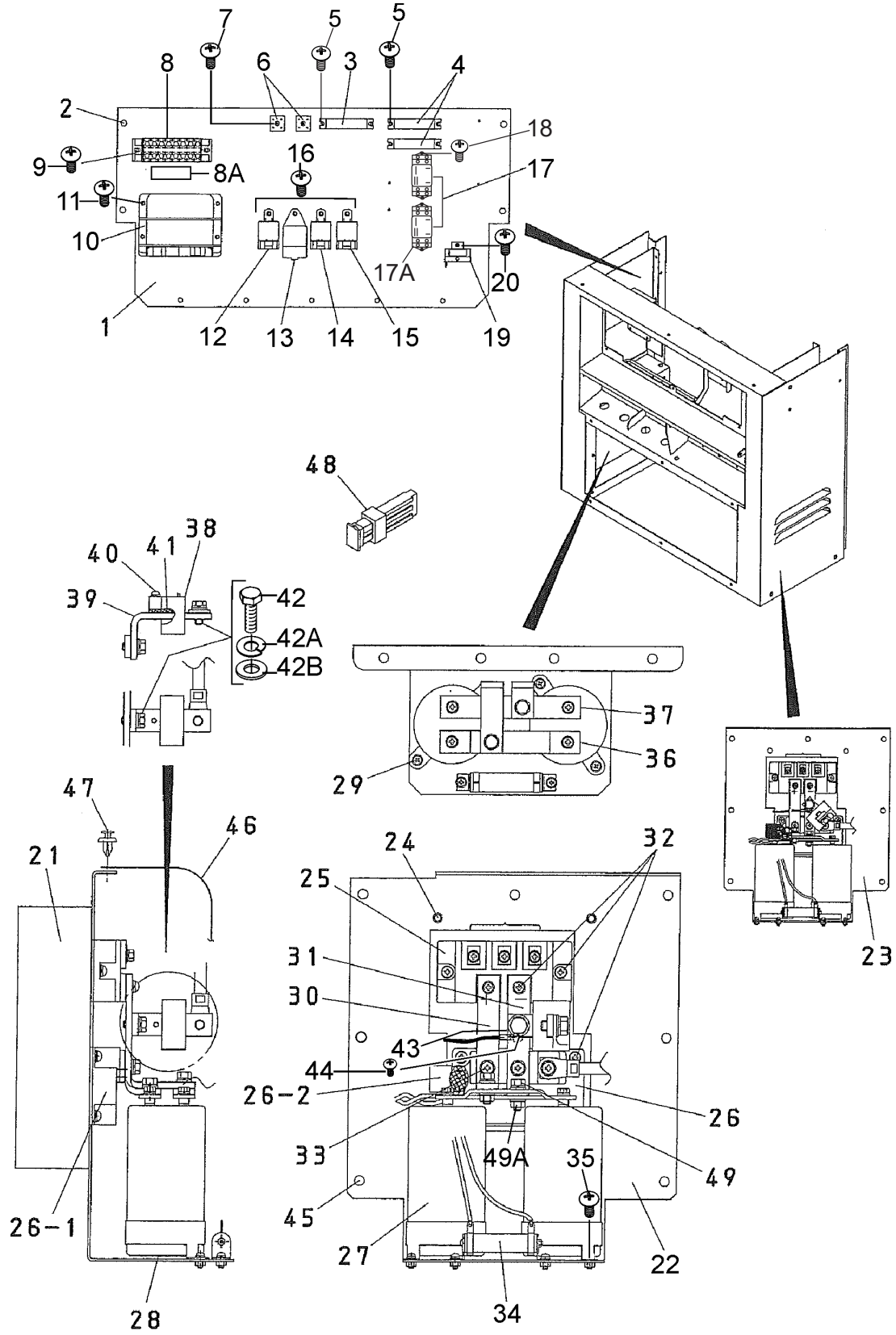

ELECTRIC PARTS 1 ASSY. (CONT'D.)

<u>NO.</u>	<u>PART NO.</u>	<u>PART NAME</u>	<u>QTY.</u>	<u>REMARKS</u>
31	D5267300304	CONNECTION PLATE	2	
32	0027105015	MACHINE SCREW (DLW400ESA4)	16	
32	0027105016	MACHINE SCREW (DLW400ESA4F)	16	
33	0017806014	HEX. HEAD BOLT	6	
34	0601842198	RESISTOR, 20W 1KΩ	2	REPLACES P/N 0601842262
35	0027104010	MACHINE SCREW	4	
36	D4268304204	CONNECTION PLATE	2	
37	D4268304304	CONNECTION PLATE	2	
38	0601804202	DC CURRENT TRANSFORMER	2	
39	D5267301004	CONNECTION PLATE	2	
40	0027104020	MACHINE SCREW	2	
41	D4235400004	INSULATOR	2	
42	0019008016	HEX. HEAD BOLT	4	
42A	0040008000	WASHER, LOCK	4	
42B	0042708000	WASHER, FLAT	4	
43	0601803660	THERMISTER	2	
44	0021003010	MACHINE SCREW	2	
45	0016906015	HEX. HEAD BOLT	14	
46	D5261700604	COVER, ELECTRIC PARTS	2	
47	Y0605011412	RIVET	10	
48	0601806640	FUSE, 65A	2	
49	011206020	HEX. HEAD BOLT	4	REPLACES P/N 0017106020
49A	0023706000	HEX. NUT	4	REPLACES P/N 0207206000

ELECTRIC PARTS 2 ASSY.

<u>NO.</u>	<u>PART NO.</u>	<u>PART NAME</u>	<u>QTY.</u>	<u>REMARKS</u>
1	D5214000403	BOX, ELECTRIC PARTS	1	
2	0016906015	HEX. HEAD BOLT	2	
3	0016906015	HEX. HEAD BOLT	2	
4	0601820664	AUTOMATIC VOLTAGE REGULATOR.....	1	INCLUDES ITEMS W/%
4A%	0601806681	FUSE, 250V 5A	1	
5	0016906015	HEX. HEAD BOLT	4	
6	D5266200004	CONTROL UNIT (DLW400ESA4).....	1	S/N 5725269 AND BELOW
6	D5266200014	CONTROL UNIT (DLW400ESA4).....	1	S/N 5725270 ~ 5732284
6	D5266200024	CONTROL UNIT (DLW400ESA4).....	1	S/N 5732285 AND ABOVE
6	D5266200024	CONTROL UNIT (DLW400ESA4F)	1	
7	Y0016904015	HEX. HEAD BOLT	6	
8	0601820836	OVER CURRENT RELAY, 42A	1	
9	0027104015	MACHINE SCREW	2	
10	0601815730	TERMINAL BOARD, 2P	1	
10A	D9521002004	DECAL; SYMBOL MARK	1	
11	0027104020	MACHINE SCREW	2	
12	D5355600304	BRACKET, GEARED MOTOR	1	
13	0016906015	HEX. HEAD BOLT	2	
14	0601822721	GEARED MOTOR, 12V	1	
15	Y0027203006	MACHINE SCREW	6	
16	D4358800014	ARM, GEARED MOTOR	1	
17	0010106020	HEX. HEAD BOLT	1	
17A	0030006000	HEX. NUT	1	
18	D4355000004	GOVERNOR ROD ASSY.	1	INCLUDES ITEMS W/#
18-1#	D4355300304	GOVERNOR ROD	1	
18-2#	D4355300204	GOVERNOR ROD	1	
18-3#	D4355600404	SPRING	1	
18-4#	Y0264900100	HOSE	1	
18-5#	Y0605515227	BAND	1	
19	0401450080	WASHER, FLAT	1	REPLACES P/N 0041208000
20	0605010503	SNAP PIN	1	
21	952404470	WASHER, FLAT	1	REPLACES P/N 0041206000
22	505015300	SNAP PIN	1	REPLACES P/N 0605010502
23	0601830370	LIMIT SWITCH	1	
24	Y0027203015	MACHINE SCREW	2	
25	8511864601A	PLATE.....	1	REPLACES P/N 8511864604
26	0016906015	HEX. HEAD BOLT	5	
27	D5261601403	BRACKET, REACTOR	1	
28	0016906015	HEX. HEAD BOLT	4	
29	D4263504303	DC REACTOR	2	
30	0016906015	HEX. HEAD BOLT	8	

ELECTRIC PARTS 2 ASSY. (CONT'D.)

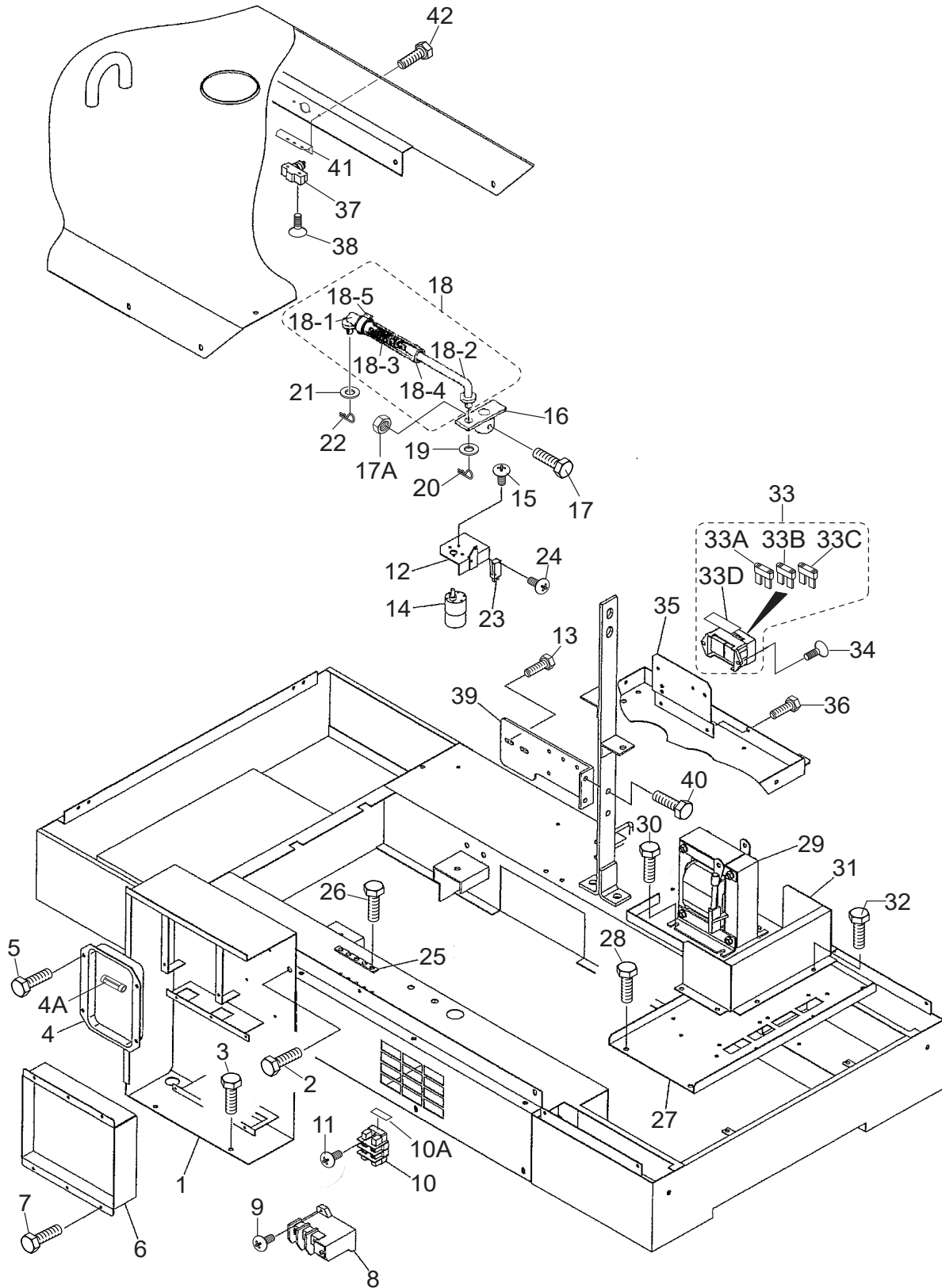

ELECTRIC PARTS 2 ASSY. (CONT'D.)

<u>NO.</u>	<u>PART NO.</u>	<u>PART NAME</u>	<u>QTY.</u>	<u>REMARKS</u>
31	D5261700704	COVER, REACTOR	1	
32	011008020	HEX. HEAD BOLT.....	6	REPLACES P/N 0016908020
33	D4213600104	FUSE BOX.....	1	INCLUDES ITEMS W/#
33A#	0601806642	FUSE, 5A	3	
33B#	0601806643	FUSE, 15A	2	
33C#	Y0601806646	FUSE, 20A	2	
33D#	D2551001104	DECAL; FUSE BOX	1	
34	Y0016905015	MACHINE SCREW	2	
35	D5261502004	BRACKET, FUSE BOX	1	
36	0016906015	HEX. HEAD BOLT	2	
37	Y0601830347	DOOR SWITCH (DLW400ESA4).....	1	S/N 5894945 AND BELOW
37	Y0601830361	DOOR SWITCH (DLW400ESA4).....	1	S/N 5894946 AND ABOVE
37	Y0601830361	DOOR SWITCH (DLW400ESA4F)	1	S/N 50013028 AND BELOW
37	Y0601830347	DOOR SWITCH (DLW400ESA4F)	1	S/N 50013029 AND ABOVE
38	0027104030	MACHINE SCREW	2	
39	D5384200004	BRACKET, GEARED MOTOR	1	
40	011008020	HEX. HEAD BOLT.....	2	REPLACES P/N 0016908020
41	D5261602704	BRACKET, DOOR SWITCH	1	S/N 5894946 AND ABOVE
41	D5261602704	BRACKET, DOOR SWITCH	1	DLW400ESA4 DLW400ESA4F S/N 50013028 AND BELOW
42	0017105015	HEX. HEAD BOLT (DLW400ESA4).....	2	S/N 5894946 AND ABOVE
42	0017105015	HEX. HEAD BOLT (DLW400ESA4F).....	2	S/N 50013028 AND BELOW

ENGINE AND RADIATOR ASSY.

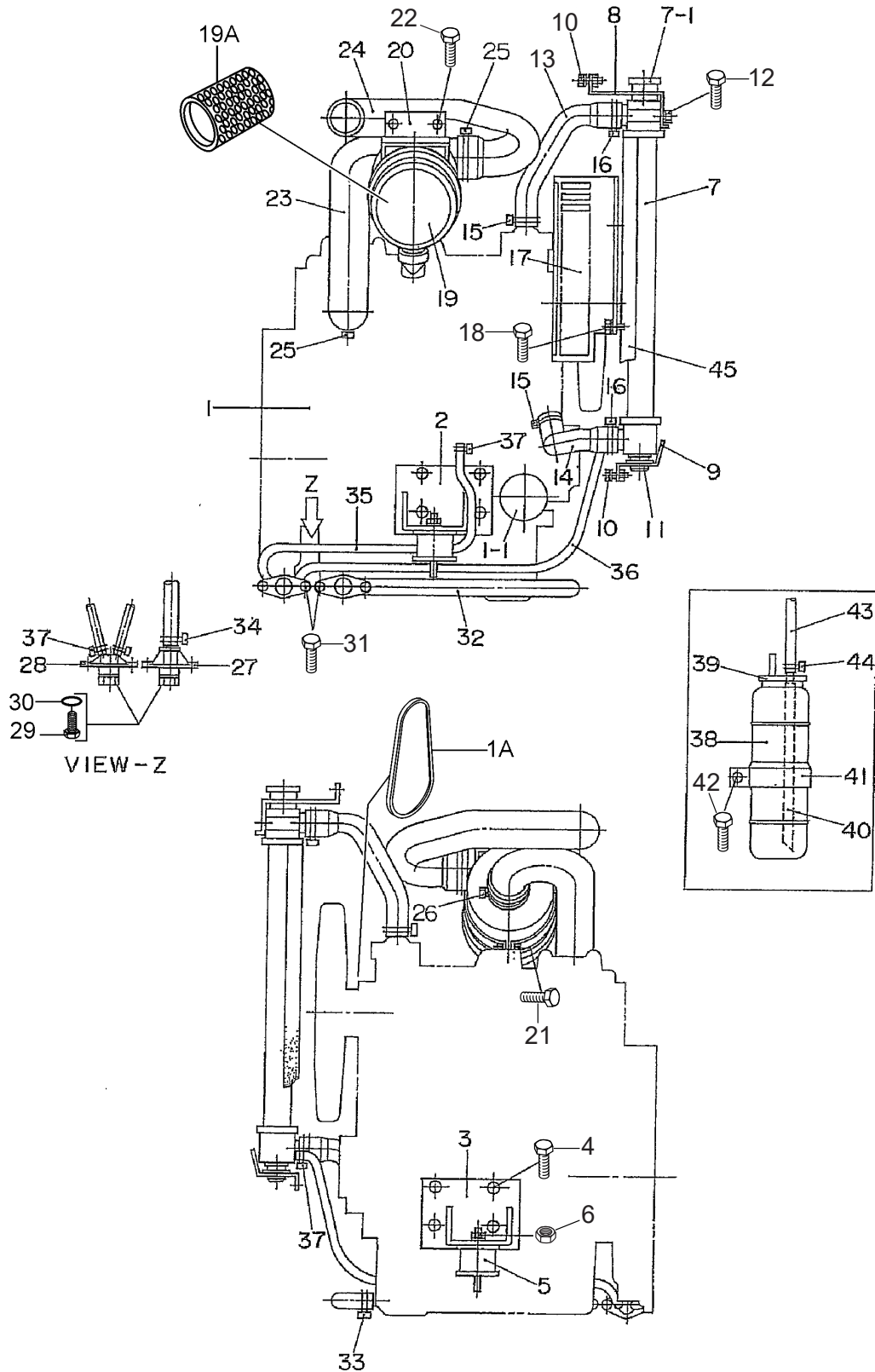

ENGINE AND RADIATOR ASSY.

<u>NO.</u>	<u>PART NO.</u>	<u>PART NAME</u>	<u>QTY.</u>	<u>REMARKS</u>
1	D2924200034	ENGINE (DLW400ESA4).....	1.....	INCLUDES ITEMS W/\$
1	D5924200244	ENGINE (DLW400ESA4F).....	1.....	INCLUDES ITEMS W/#
1A\$#	1747297011	FAN BELT	1.....	REPLACES P/N 0602011470
1-1\$#	HH15032430	CARTRIDGE, OIL FILTER	1.....	REPLACES P/N 1585332435
2	D5304201004	ENGINE FOOT	1	
3	D5304200904	ENGINE FOOT	1	
4	012210020	HEX. HEAD BOLT.....	8.....	REPLACES P/N 0010710020
5	7605419004A	RUBBER SUSPENSION	4.....	REPLACES P/N 7605419004
6	021112140	HEX. NUT	4.....	REPLACES P/N 0207010000
7	Y0602012721	RADIATOR.....	1.....	INCLUDES ITEMS W/&
7-1&	0602011079	CAP, RADIATOR	1	
8	D5311100704	BRACKET, RADIATOR	1	
9	D5311100604	BRACKET, RADIATOR	1	
10	0016906015	HEX. HEAD BOLT	5	
11	B1312600004	RUBBER MOUNT	2	
12	0016906015	HEX. HEAD BOLT	2	
13	D5311501104	RADIATOR HOSE, UPPER	1	
14	D5311501203	RADIATOR HOSE, LOWER	1	
15	0605515003	HOSE BAND	2	
16	0605515134	HOSE BAND	2	
17	D5311200303	FAN GUARD	1	
18	0016906015	HEX. HEAD BOLT	2	
19	0602046266	AIR CLEANER.....	1.....	INCLUDES ITEMS W/%
19A%	0602046391	ELEMENT, AIR CLEANER	1	
20	D4374200304	BRACKET, AIR CLEANER	1	
21	011208025	HEX. HEAD BOLT.....	1.....	REPLACES P/N 0016908025
22	011008020	HEX. HEAD BOLT.....	2.....	REPLACES P/N 0016908020
23	D4374100103	HOSE, AIR CLEANER	1	
24	D4374100003	HOSE, AIR CLEANER	1	
25	0602014302	HOSE BAND.....	2.....	REPLACES P/N 0605515021
26	0605515006	HOSE BAND	1	
27	1502025103C	DRAIN JOINT, OIL.....	1.....	REPLACES P/N 1502025103
28	1622014103	DRAIN JOINT, WATER	1	
29	0802011104	PLUG	2	
30	0150000018	O-RING	2	
31	0016906015	HEX. HEAD BOLT	4	
32	D2311100003	DRAIN HOSE (DLW400ESA4)	1	
32	D2321100003	DRAIN HOSE (DLW400ESA4F)	1	
33	0605515132	HOSE BAND	1	
34	0605515132	HOSE BAND	1	
35	0199900620	DRAIN HOSE	1	
36	0199900850	DRAIN HOSE	1	
37	0605515094	HOSE BAND	4	
38	0802081403	RESERVE TANK	1	
39	0802081104	CAP, RESERVE TANK	1	
40	0199100215	HOSE	1	
41	8702082004	BRACKET, RESERVE TANK	1	
42	0016906015	HEX. HEAD BOLT	1	
43	Y0199900460	HOSE	1	
44	0605515094	HOSE BAND	2	
45	0220300400	RUBBER SEAL	2	

BATTERY ASSY.

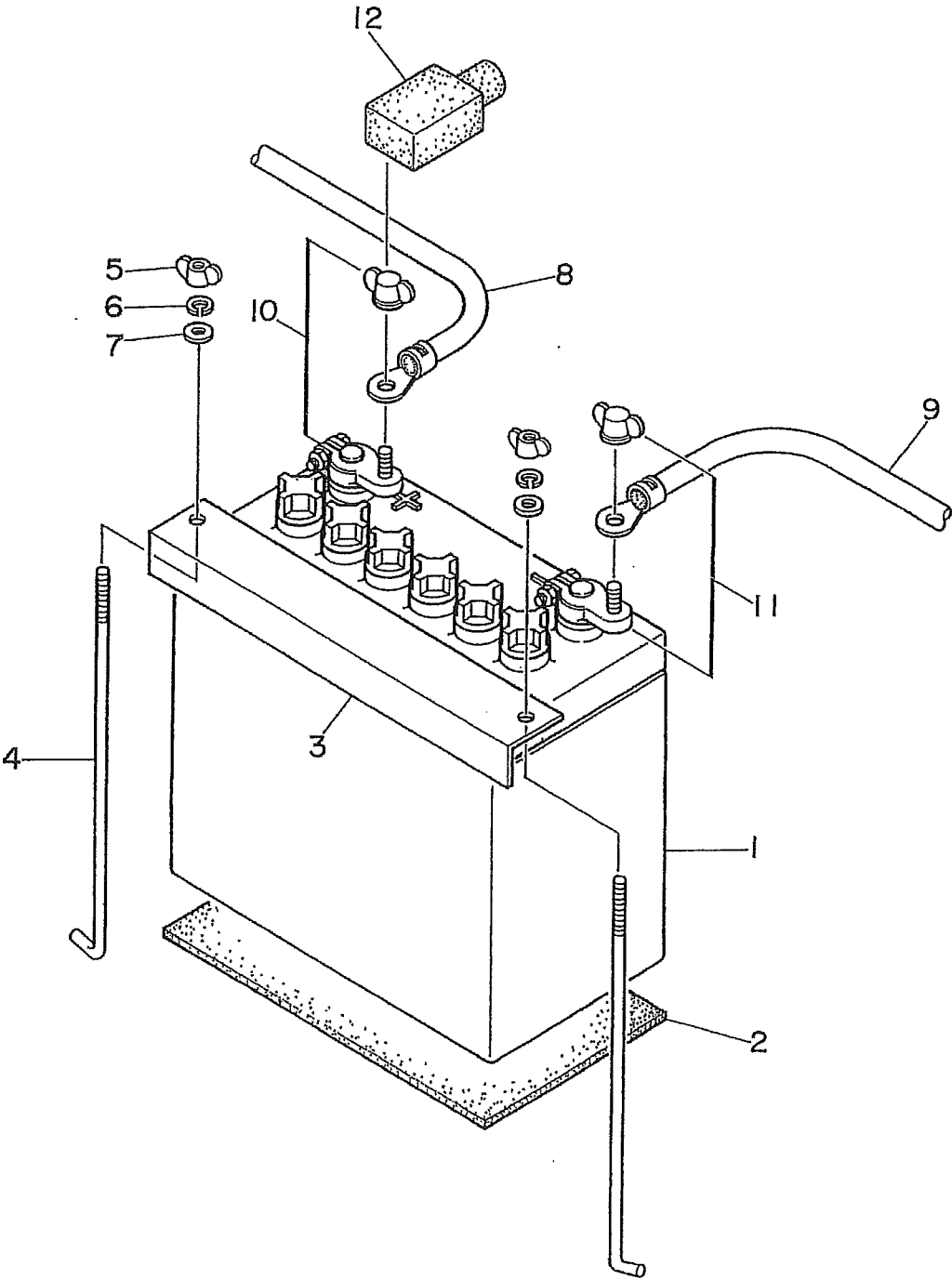

BATTERY ASSY.

<u>NO.</u>	<u>PART NO.</u>	<u>PART NAME</u>	<u>QTY.</u>	<u>REMARKS</u>
1	0169105524	BATTERY, 55B24L.....	1.....	REPLACES P/N 0166105524
2	8722251004	BATTERY SHEET	1	
3	7552253004	BATTERY BAND	1	
4	7872251004	BATTERY BOLT	2	
5	0037806000	WING NUT	2	
6	0040006000	WASHER, LOCK	2	
7	952404470	WASHER, FLAT.....	2.....	REPLACES P/N 0041206000
8		BATTERY CABLE.....	1.....	PURCHASE LOCALLY
9		BATTERY CABLE.....	1.....	PURCHASE LOCALLY
10	0602220312	TERMINAL ASSY., NO.15L (+)	1	
11	0602220313	TERMINAL ASSY., NO.15L (-)	1	
12	0845040414	TERMINAL CAP.....	1.....	REPLACES P/N 0602220600

MUFFLER ASSY.

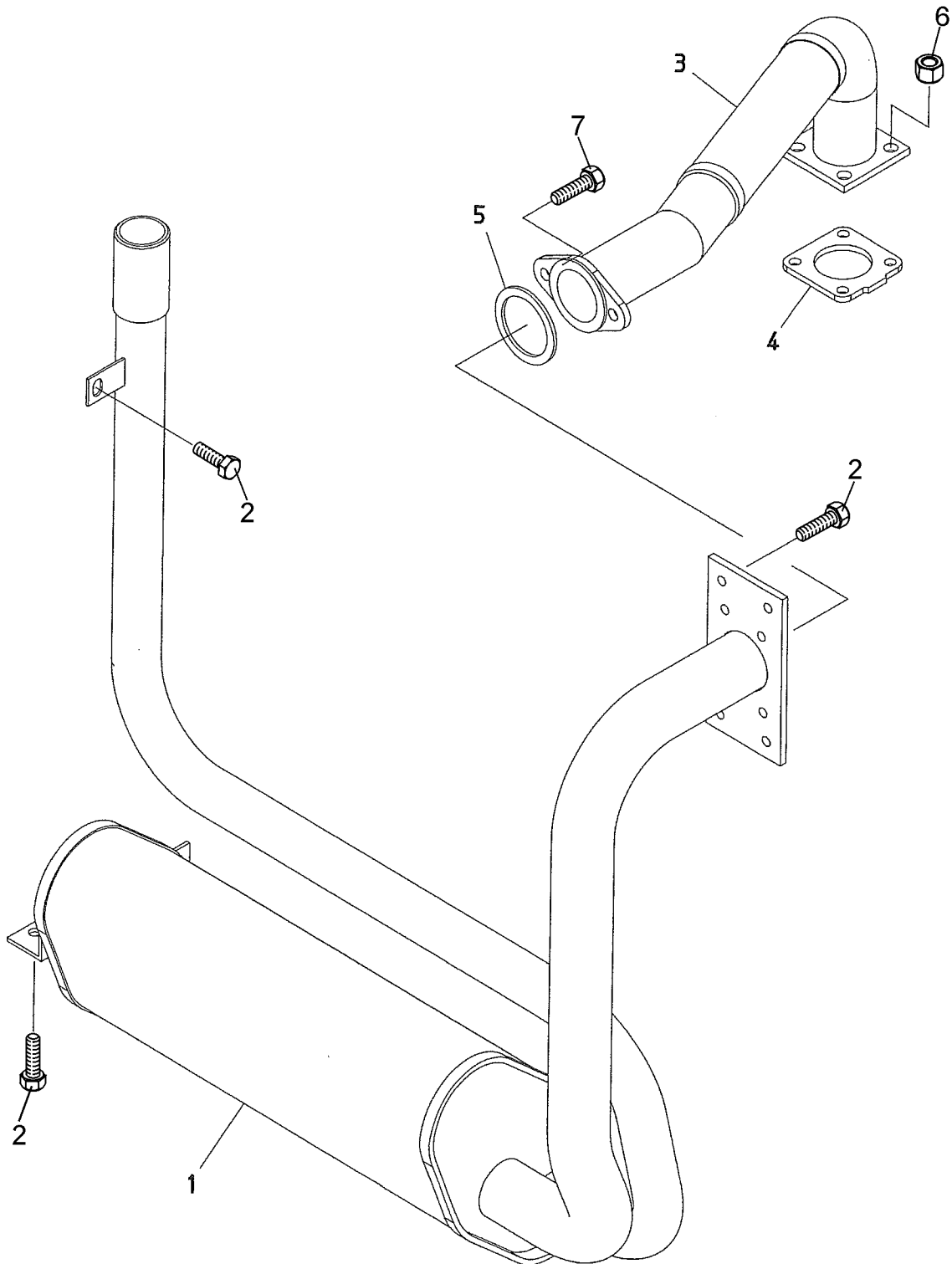

MUFFLER ASSY.

<u>NO.</u>	<u>PART NO.</u>	<u>PART NAME</u>	<u>QTY.</u>	<u>REMARKS</u>
1	D5331001903	MUFFLER	1	
2	011008020	HEX. HEAD BOLT.....	9.....	REPLACES P/N 0016908020
3	D5334000803	EXHAUST PIPE	1	
4	1526312371	GASKET	1.....	REPLACES P/N 0602320153
5	D9304000104	GASKET	1	
6	Y0207008000	HEX. NUT	4	
7	011208030	HEX. HEAD BOLT.....	2.....	REPLACES P/N 0016908030

FUEL TANK ASSY.

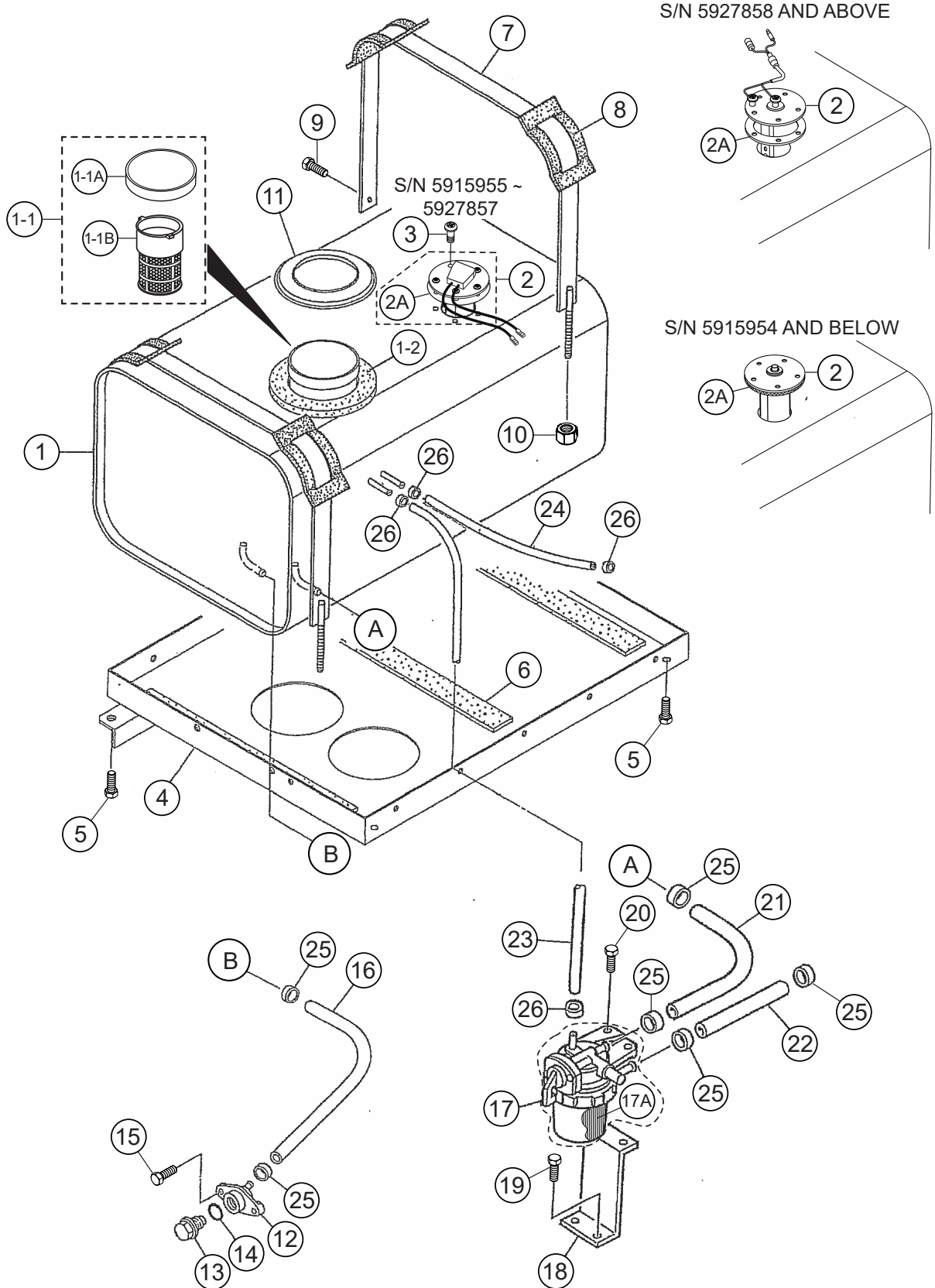

FUEL TANK ASSY.

<u>NO.</u>	<u>PART NO.</u>	<u>PART NAME</u>	<u>QTY.</u>	<u>REMARKS</u>
1	D5364000703	FUEL TANK ASSY.	1	
1-1	A9924800024	CAP, FUEL TANK ASSY.....	1	INCLUDES ITEMS W/@
1-1A@	A9924800024	CAP, FUEL TANK.....	1	REPLACES P/N 0810105800
1-1B@	0810105900	FUEL FILTER	1	
1-2	D9311400204	RUBBER SEAL	1	
2	B4925300004	SENDER, FUEL GAUGE, I-261.....	1	INCLUDES ITEMS W/# DLW400ESA4 S/N 5795334 AND BELOW
2	B4924300224	SENDER, FUEL GAUGE, UT06-I-261.....	1	INCLUDES ITEMS W/% DLW400ESA4 S/N 5795335 ~ 5915954
2	B4924300434	SENDER, FUEL GAUGE, I-261AS.....	1	DLW400ESA4 S/N 5915955 ~ 5927857
2	B4924300504	SENDER, FUEL GAUGE, I-261JW.....	1	INCLUDES ITEMS W/& DLW400ESA4 S/N 5927858 AND ABOVE
2	B4924300504	SENDER, FUEL GAUGE, I-261JW.....	1	DLW400ESA4F INCLUDES ITEMS W/*
2A#	E1924300184	GASKET, SRNO9,010A.....	1	DLW400ESA4 S/N 5795334 AND BELOW
2A%	B3924300184	GASKET, UT06-601.....	1	DLW400ESA4 S/N 5795335 ~ 5915954
2A&	B3924300514	GASKET	1	DLW400ESA4 S/N 5915955 AND ABOVE
2A*	B3924300514	GASKET	1	DLW400ESA4F
3	0022905015	MACHINE SCREW	5	
4	D5434000403	BRACKET, FUEL TANK	1	
5	011008020	HEX. HEAD BOLT.....	4	REPLACES P/N 0016908020
6	0222100320	TANK SHEET	3	
7	D5364200404	TANK BAND	2	
8	D6365300504	PAD, TANK BAND	4	
9	011008020	HEX. HEAD BOLT.....	2	REPLACES P/N 0016908020
10	0207308000	HEX. NUT	2	
11	B9312400004	RUBBER SEAL	1	
12	7812014003	DRAIN JOINT	1	
13	0802011104	PLUG	1	
14	0150000018	O-RING	1	
15	0016906015	HEX. HEAD BOLT	2	

FUEL TANK ASSY. (CONT'D.)

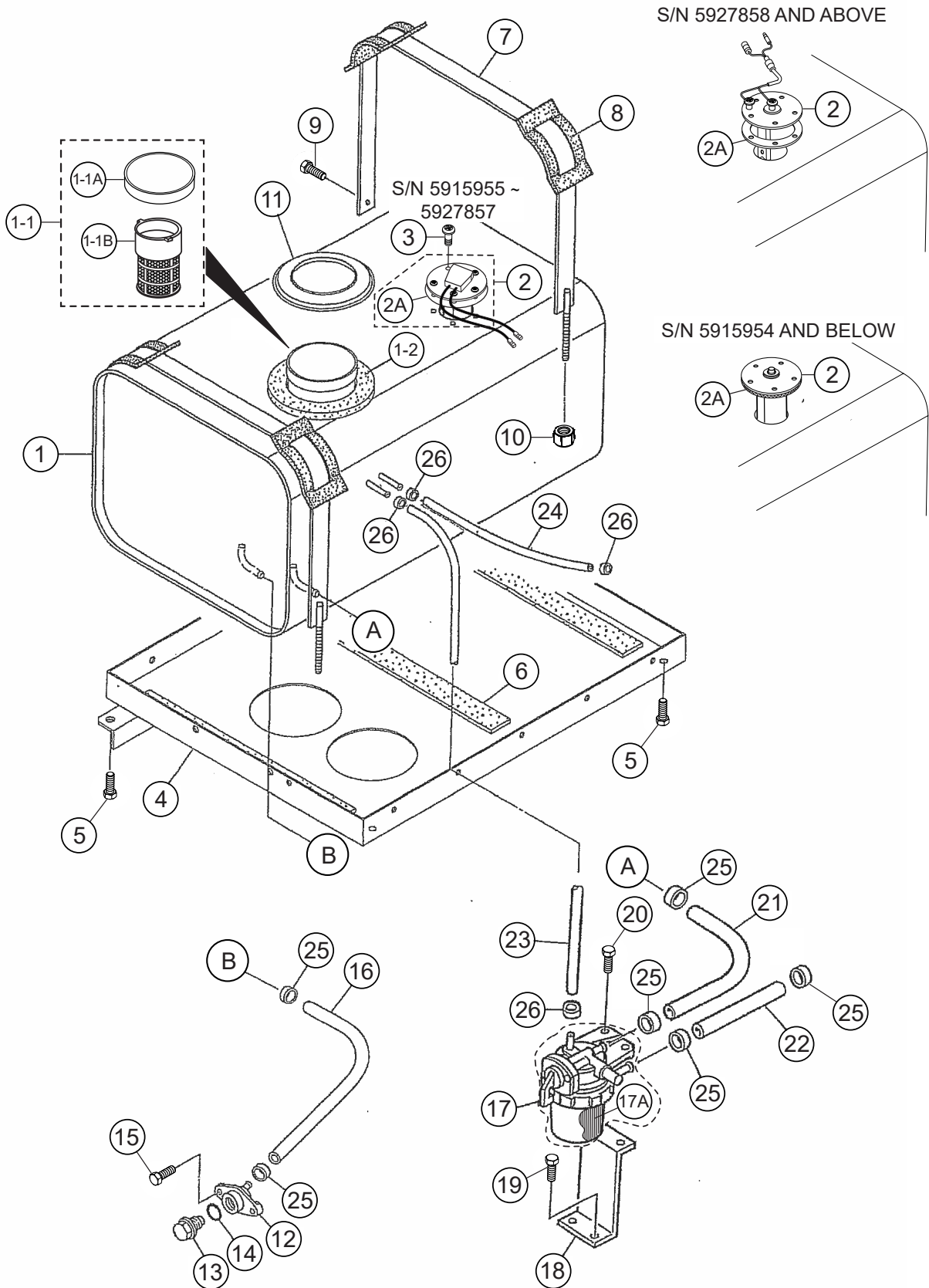

FUEL TANK ASSY. (CONT'D.)

<u>NO.</u>	<u>PART NO.</u>	<u>PART NAME</u>	<u>QTY.</u>	<u>REMARKS</u>
16	Y0370600900	DRAIN HOSE	1	
17	1552143014	FUEL FILTER.....	1.....	INCLUDES ITEMS W/\$ REPLACES P/N Y0602042467
17A\$	1552143160	ELEMENT, FUEL FILTER.....	1.....	REPLACES P/N 0602042174
18	D4367700004	BRACKET, FUEL FILTER	1	
19	0016906015	HEX. HEAD BOLT	2	
20	011208025	HEX. HEAD BOLT.....	2.....	REPLACES P/N 0016908025
21	Y0370600360	SUCTION HOSE	1	
22	Y0370600750	SUCTION HOSE	1	
23	Y0370700500	RETURN HOSE	1	
24	Y0370700350	RETURN HOSE	1	
25	0605515094	HOSE BAND	6	
26	0605515200	HOSE BAND	4	

ENCLOSURE ASSY.

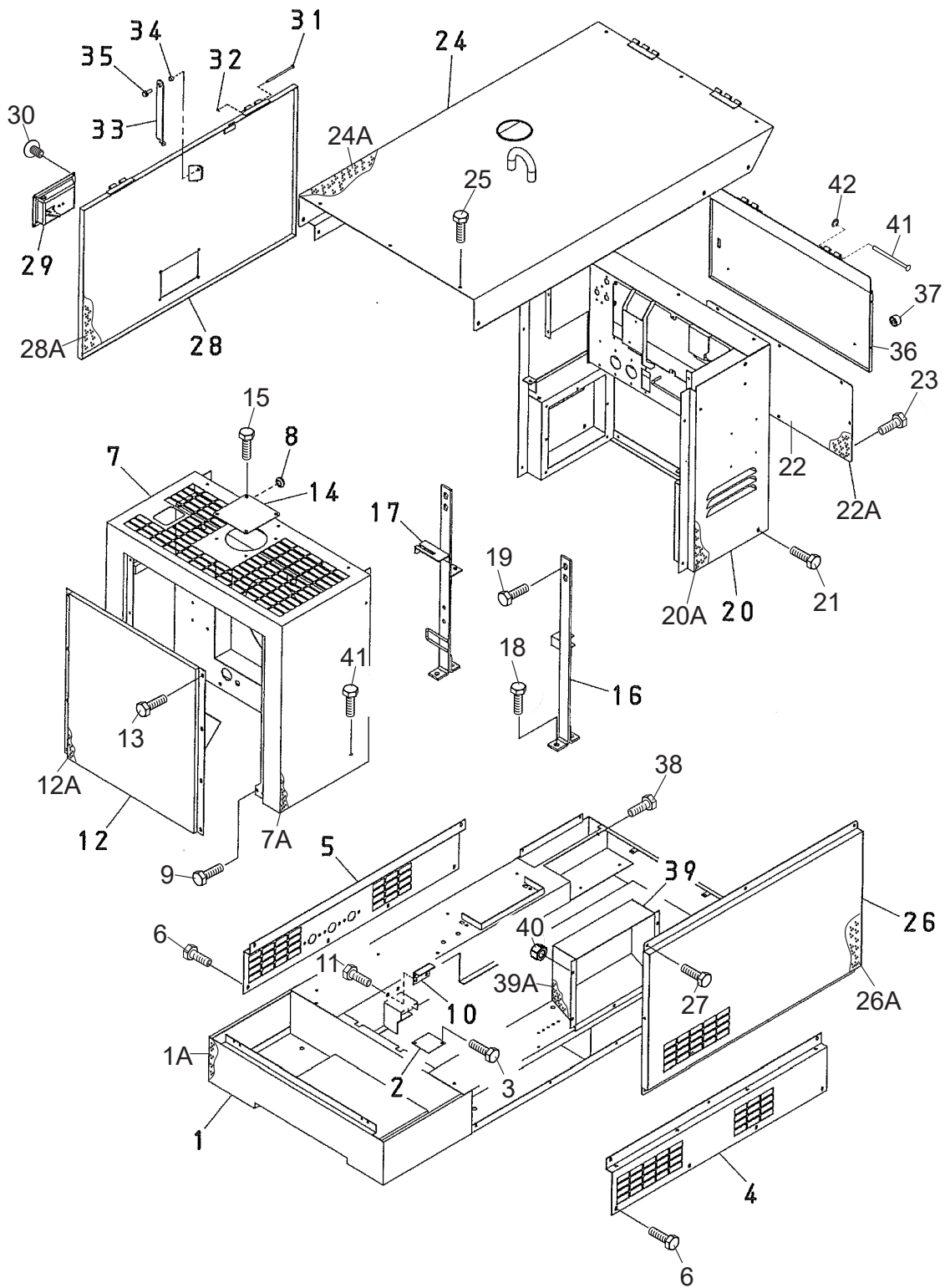

ENCLOSURE ASSY.

<u>NO.</u>	<u>PART NO.</u>	<u>PART NAME</u>	<u>QTY.</u>	<u>REMARKS</u>
1	D5414001602	BASE	1	
1A	D5494001603	LINING	1	
2	D3414800104	FLOOR PANEL	1	
3	0016906015	HEX. HEAD BOLT	2	
4	D6414300103	SPLASHER PANEL	1	
5	D5414300503	SPLASHER PANEL	1	
6	0016906015	HEX. HEAD BOLT	18	
7	D5424001102	FRONT FRAME	1	
7A	D5494101303	LINING	1	
8	0601850239	GROMMET	1	
9	0016906015	HEX. HEAD BOLT	2	
10	D4304200604	STOPPER	2	
11	011008020	HEX. HEAD BOLT.....	4	REPLACES P/N 0016908020
12	D5424200903	COVER, FRONT FRAME	1	
12A	D5494100404	LINING	1	
13	0016906015	HEX. HEAD BOLT	8	
14	D4425200804	COVER, RADIATOR CAP	1	
15	0016906015	HEX. HEAD BOLT	4	
16	D5434301103	HANGER	1	
17	D5434301003	HANGER	1	
18	0012312030	HEX. HEAD BOLT	4	
19	0012312030	HEX. HEAD BOLT	4	
20	D5444002402	REAR FRAME	1	
20A	D5494301804	LINING	1	
21	0016906015	HEX. HEAD BOLT	4	
22	D5444301104	COVER REAR FRAME	1	
22A	D5494301704	LINING	1	
23	0016906015	HEX. HEAD BOLT	8	
24	D5464001202	ROOF PANEL (DLW400ESA4).....	1	S/N 5894945 AND BELOW
24	D5464002002	ROOF PANEL (DLW400ESA4).....	1	S/N 5894946 AND ABOVE
24	D5464002002	ROOF PANEL (DLW400ESA4F).....	1	S/N 50013028 AND BELOW
24	D5464001202	ROOF PANEL (DLW400ESA4F).....	1	S/N 50013029 AND ABOVE
24A	D5494500904	LINING	1	
25	0016906015	HEX. HEAD BOLT	14	
26	D6454100003	SIDE PANEL	1	
26A	D5494402204	LINING	1	
27	0016906015	HEX. HEAD BOLT	6	
28	D5454001703	SIDE DOOR (DLW400ESA4)	1	S/N 5894945 AND BELOW
28	D5454003303	SIDE DOOR (DLW400ESA4)	1	S/N 5894946 AND ABOVE
28	D5454003303	SIDE DOOR (DLW400ESA4F)	1	S/N 50013028 AND BELOW
28	D5454001703	SIDE DOOR (DLW400ESA4F)	1	S/N 50013029 AND ABOVE
28A	D5494402104	LINING	1	
29	B9114000002	DOOR HANDLE	1	
30	0021806015	MACHINE SCREW	4	

ENCLOSURE ASSY. (CONT'D.)

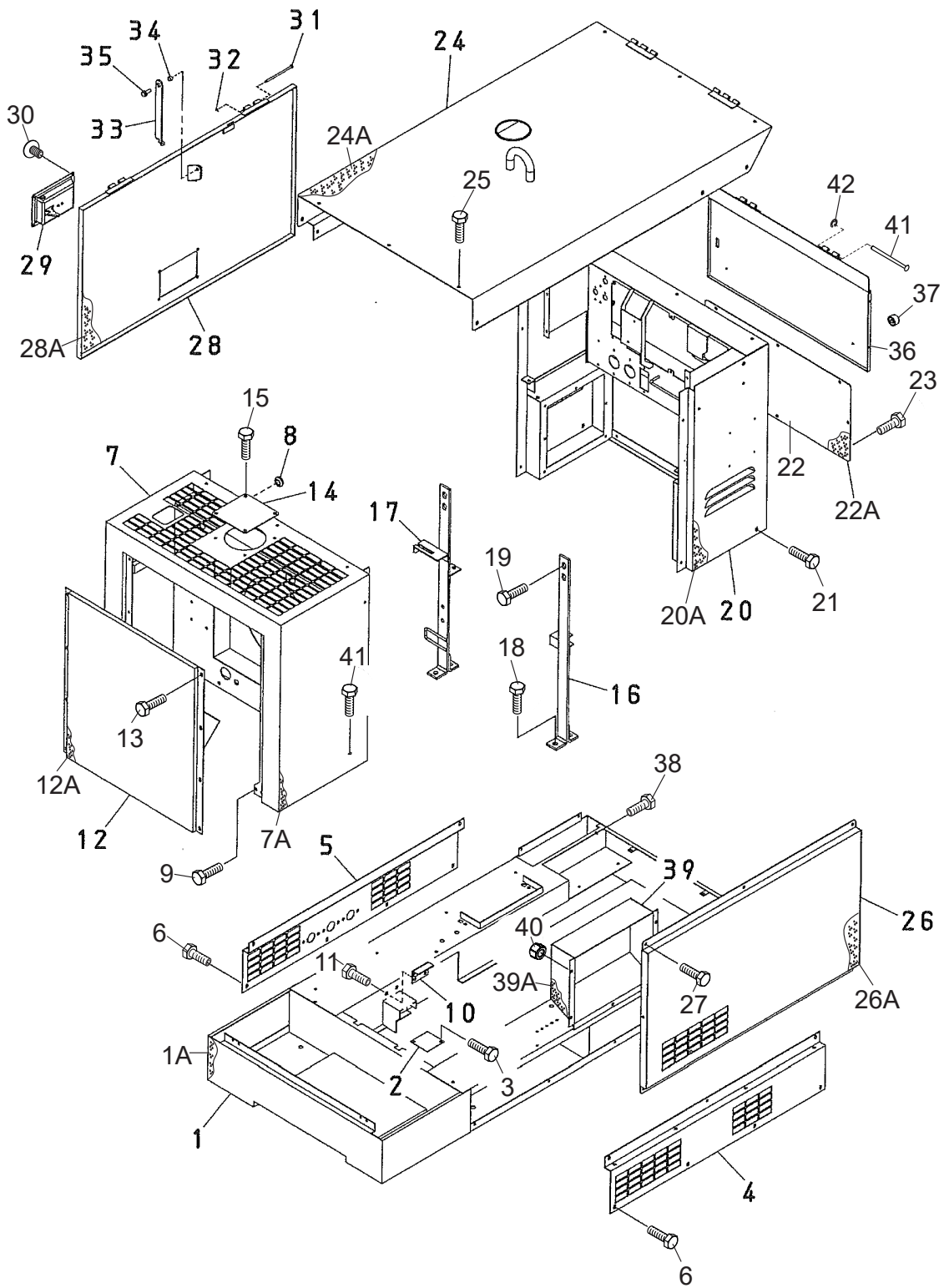

ENCLOSURE ASSY. (CONT'D.)

<u>NO.</u>	<u>PART NO.</u>	<u>PART NAME</u>	<u>QTY.</u>	<u>REMARKS</u>
31	0810014704	PIN	2	
32	0080200004	SNAP RING	2	
33	7835186014	DOORSTAY	1	
34	7835088004	COLLAR	1	
35	011208030	HEX. HEAD BOLT.....	1.....	REPLACES P/N 0016908030
36	D5444200003	REAR DOOR	1	
37	0601851613	STOPPER	2	
38	011008020	HEX. HEAD BOLT.....	4.....	REPLACES P/N 0016908020
39	D6454300003	DUCT	1	
39A	D6494400404	LINING	1	
40	0176060030	HEX. NUT	5.....	REPLACES P/N 0207006000
41	0810014704	PIN	2	
42	0080200004	SNAP RING	2	

RUBBER SEALS ASSY.

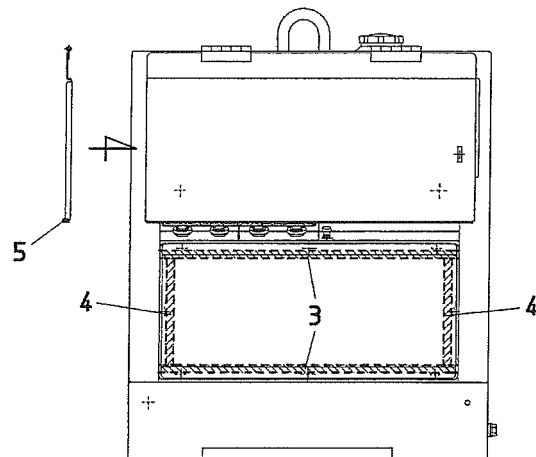
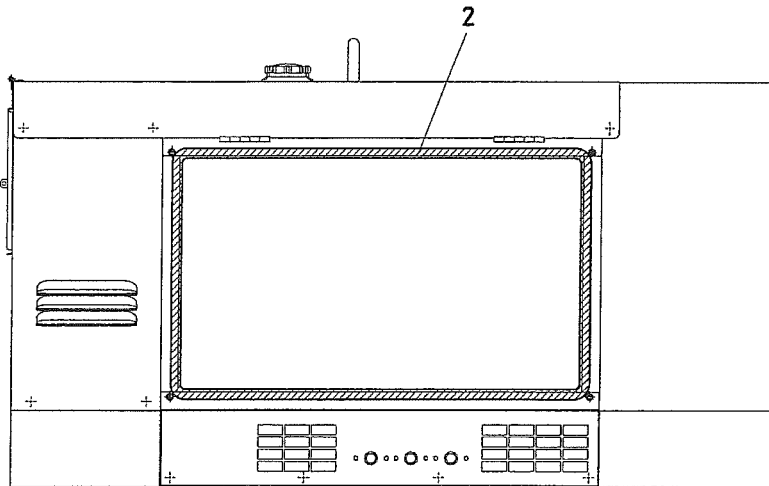
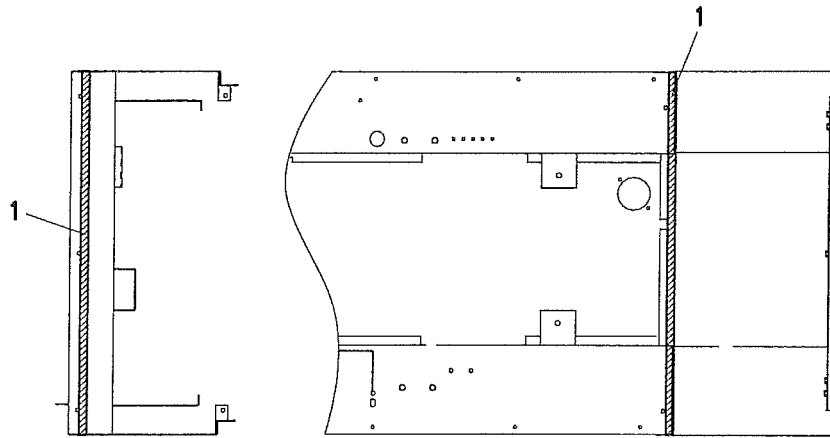

RUBBER SEALS ASSY.

<u>NO.</u>	<u>PART NO.</u>	<u>PART NAME</u>	<u>QTY.</u>	<u>REMARKS</u>
1	Y0314900715	RUBBER SEAL	2	
2	0314602550	RUBBER SEAL	1	
3	0314900590	RUBBER SEAL	2	
4	Y0314900210	RUBBER SEAL	2	
5	0226900650	RUBBER SEAL	1	

DLW400ESA4 NAMEPLATE AND DECALS ASSY.

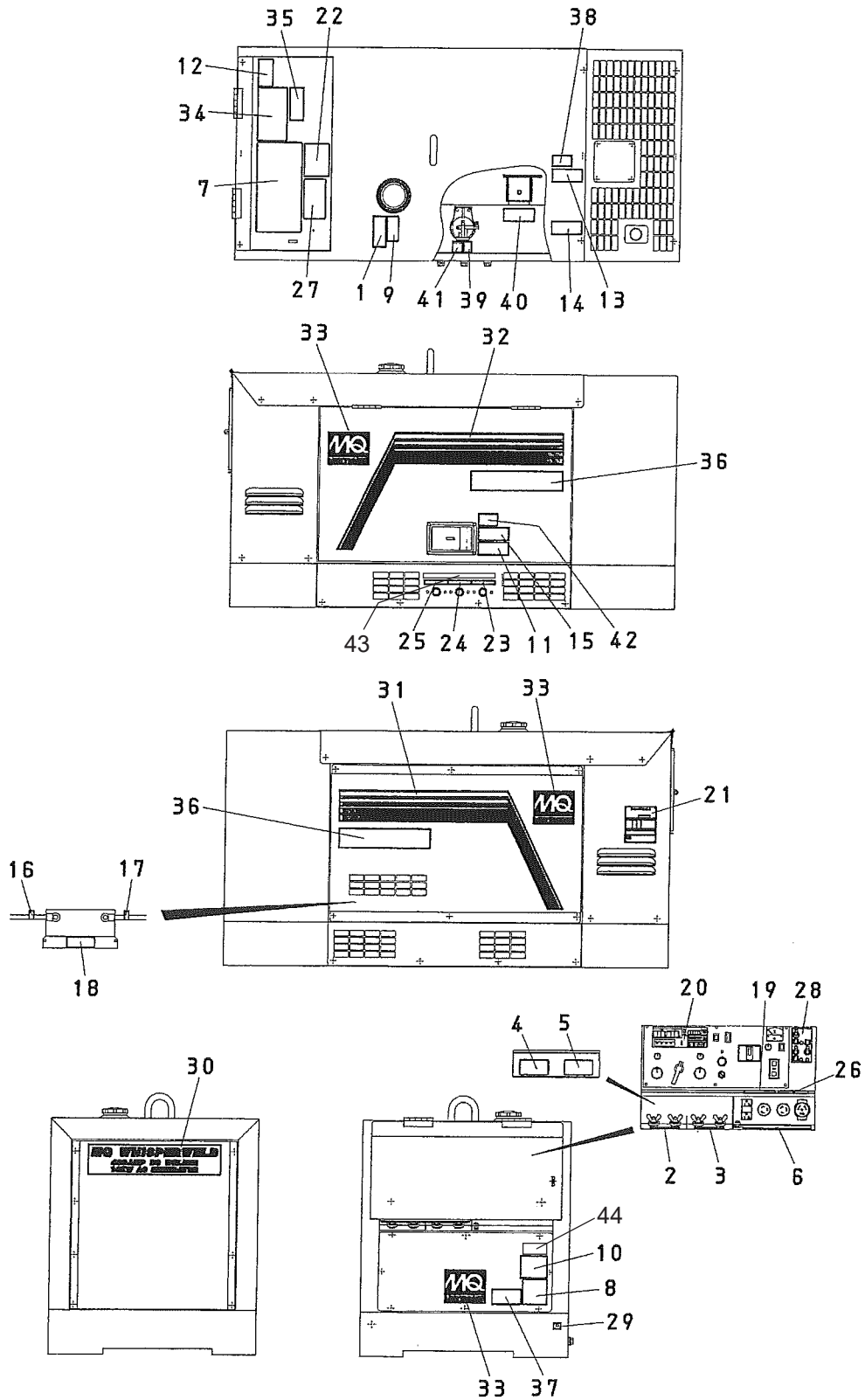

DLW400ESA4 NAMEPLATE AND DECALS ASSY.

<u>NO.</u>	<u>PART NO.</u>	<u>PART NAME</u>	<u>QTY.</u>	<u>REMARKS</u>
1	B9504500004	DECAL; WARNING.....	1.....	B90450000
2	D5551001904	DECAL; A WELDING OUTPUT TERMINAL	1.....	D55100190
3	D5551002004	DECAL; B WELDING OUTPUT TERMINAL	1.....	D55100200
4	D5551002104	DECAL; A WELDING OUTPUT TERMINAL	1.....	D55100210
5	D5551002204	DECAL; B WELDING OUTPUT TERMINAL	1.....	D55100220
6	D5551001703	DECAL; OUTPUT TERMINAL	1.....	D55100170
7	D2551000703	DECAL; OPERATION	1.....	D25100070A S/N 5846356 AND BELOW
7	D2551000713	DECAL; OPERATION	1.....	D25100071 S/N 5846357 AND ABOVE
8	D9531100004	DECAL; WARNING EARTH GROUND.....	1.....	D93110000
9	B9504501214	DECAL; DIESEL FUEL	1.....	B90450121
10	A9504000014	DECAL; DANGER.....	1.....	A90400001
11	B9504000404	DECAL; WARNING MOVING PARTS	1.....	B90400040
12	0820610404	DECAL; WARNING.....	1.....	S-3627
13	B9504100104	DECAL; WARNING HOT COOLANT.....	1.....	B90410010
14	W8700611804	DECAL; WARNING DANGEROUS	1.....	S-4984
15	B9504000304	DECAL; WARNING HOT PARTS.....	1.....	B90400030
16	0800689404	DECAL; +	1.....	S-2090
17	0800689504	DECAL; -	1.....	S-2091
18	0820650604	DECAL; CAUTION BATTERY	1	
19	8700611904	DECAL; DANGER, ELEC. SHOCK HAZARD.....	1.....	S-4985
20	D2551000603	DECAL; OPERATION INDICATION	1	
21	D5531106604	DECAL; SPECIFICATION.....	1.....	D53110660A
22	6390671104	DECAL; IMPORTANT CHECK DAILY.....	1.....	S-2377
23	1630645004	DECAL; OIL DRAIN	1.....	S-1403 S/N 5788859 AND BELOW
24	1630647004	DECAL; WATER DRAIN	1.....	S-1404 S/N 5788859 AND BELOW
25	7810680104	DECAL; FUEL DRAIN.....	1.....	S-3060 S/N 5788859 AND BELOW
26	B9511100304	DECAL; WARNING.....	1.....	B91110030
27	D2551001004	DECAL; ERROR CODES	1.....	D25100100
28	D5551005703	DECAL; PROTECTOR	1.....	D55100570
29	0800628504	DECAL; GROUND	1.....	S-1123
30	D5562000002	DECAL; MQ WHISPERWELD	1.....	D56200000
31	D5562100002	STRIPE	1.....	D56210000A
32	D5562100102	STRIPE.....	1.....	D56210010B
33	D3561000104	DECAL; MQ	3	
34	D9512100203	DECAL; CAUTION ON WELDING OPER.	1.....	D91210020A
35	DCL160	DECAL; PROPOSITION 65 WARNING.....	1.....	D92210020 REPLACES P/N D9522100204 S/N 5821589 AND BELOW

DLW400ESA4 NAMEPLATE AND DECALS ASSY. (CONT'D.)

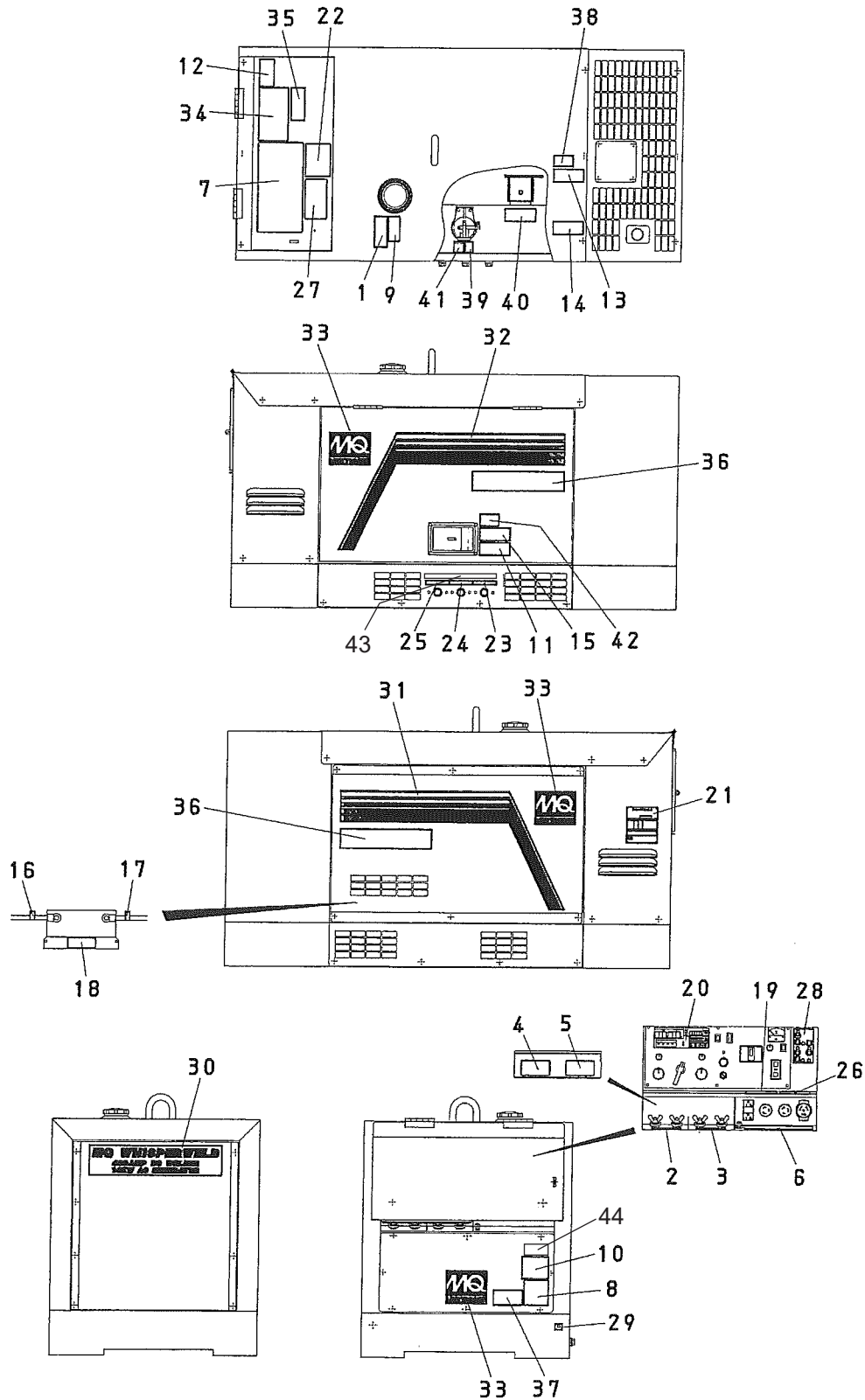

DLW400ESA4 NAMEPLATE AND DECALS ASSY. (CONT'D.)

<u>NO.</u>	<u>PART NO.</u>	<u>PART NAME</u>	<u>QTY.</u>	<u>REMARKS</u>
36	D9511200503	DECAL; SMART STICK.....	2.....	S/N 5813520 AND BELOW
36	D9511200803	DECAL; SMART STICK.....	2.....	S/N 5813521 AND ABOVE
37	920214100	DECAL; WARNING START FIRES.....	1.....	M90420000 REPLACES P/N M9504200004
38	W7810680204	DECAL; COOLING WATER.....	1.....	S-3061
39	1980680004	DECAL; FUEL COCK.....	1.....	S-3704
40	8700611524	DECAL; CAUTION OIL LEVEL GAUGE	1.....	S-4926B
41	1630610404	DECAL; CAUTION FUEL FILTER.....	1.....	S-1406
42	1630610504	DECAL; CAUTION DOOR.....	1.....	S-1409
43	D5551007704	DECAL; FUEL, WATER, OIL DRAIN	1.....	D55100770 S/N 5788860 AND ABOVE
44	A9511101304	DECAL; WARNING PROPOSITION 65.....	1.....	A91110130 S/N 5821590 AND ABOVE

DLW400ESA4F NAMEPLATE AND DECALS ASSY.

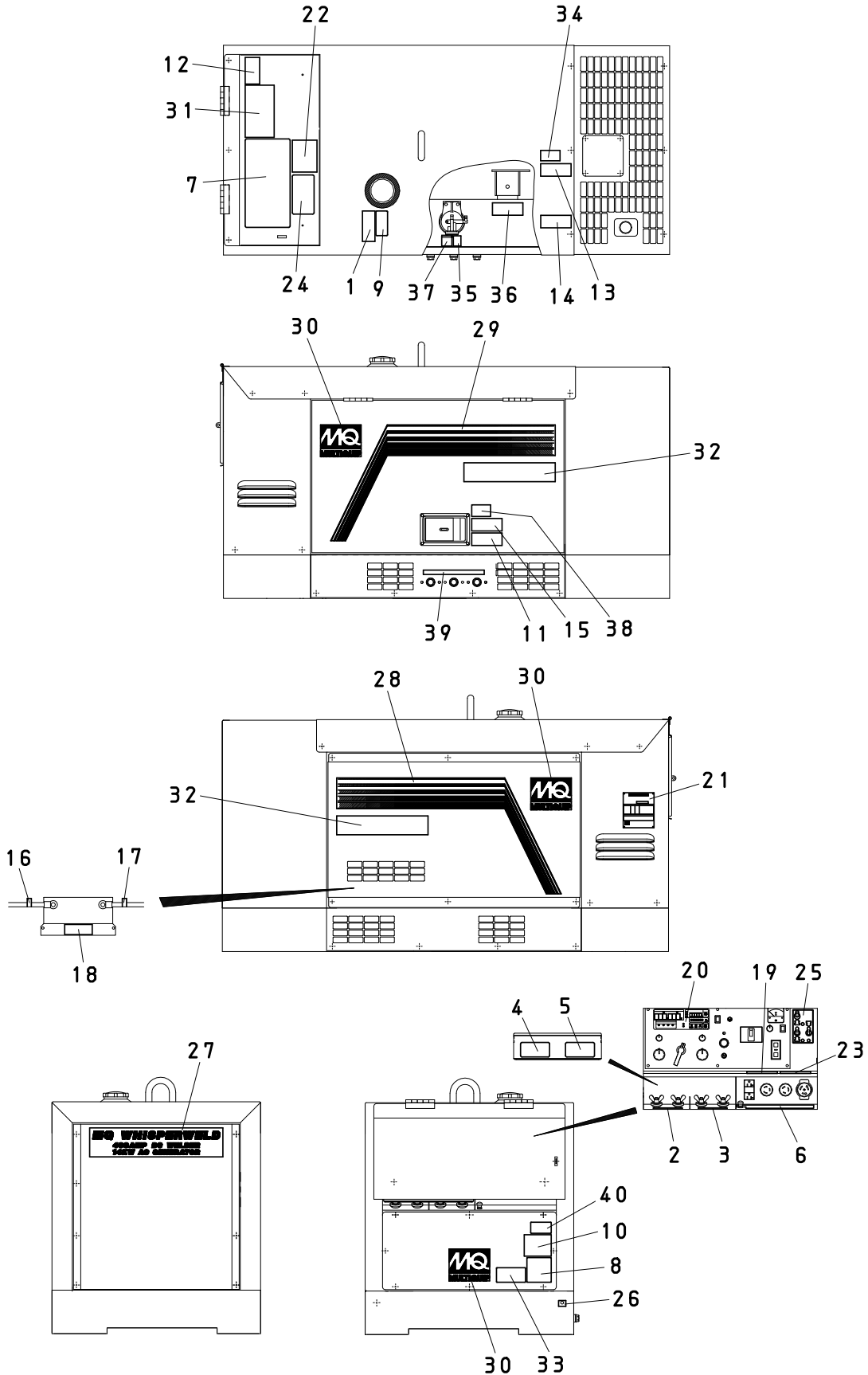

DLW400ESA4F NAMEPLATE AND DECALS ASSY.

<u>NO.</u>	<u>PART NO.</u>	<u>PART NAME</u>	<u>QTY.</u>	<u>REMARKS</u>
1	B9504500004	DECAL; WARNING.....	1.....	B90450000
2	D5551001904	DECAL; A WELDING OUTPUT TERMINAL	1.....	D55100190
3	D5551002004	DECAL; B WELDING OUTPUT TERMINAL	1.....	D55100200
4	D5551002104	DECAL; A WELDING OUTPUT TERMINAL	1.....	D55100210
5	D5551002204	DECAL; B WELDING OUTPUT TERMINAL.....	1.....	D55100220
6	D5551001703	DECAL; OUTPUT TERMINAL	1.....	D55100170
7	D2551000713	DECAL; OPERATION	1.....	D25100071
8	D9531100004	DECAL; WARNING EARTH GROUND.....	1.....	D93110000
9	B9504501214	DECAL; DIESEL FUEL	1.....	B90450121
10	A9504000014	DECAL; DANGER.....	1.....	A90400001
11	B9504000404	DECAL; WARNING MOVING PARTS	1.....	B90400040
12	0820610404	DECAL; WARNING.....	1.....	S-3627
13	B9504100104	DECAL; WARNING HOT COOLANT.....	1.....	B90410010
14	W8700611804	DECAL; WARNING DANGEROUS	1.....	S-4984
15	B9504000304	DECAL; WARNING HOT PARTS.....	1.....	B90400030
16	0800689404	DECAL; +	1.....	S-2090
17	0800689504	DECAL; -.....	1.....	S-2091
18	0820650604	DECAL; CAUTION BATTERY	1	
19	8700611904	DECAL; DANGER, ELEC. SHOCK HAZARD....	1.....	S-4985
20	D2551000603	DECAL; OPERATION INDICATION	1	
21	D5531108604	DECAL; SPECIFICATION.....	1.....	D53110860
22	6390671104	DECAL; IMPORTANT CHECK DAILY.....	1.....	S-2377
23	B9511100304	DECAL; WARNING.....	1.....	B91110030
24	D2551001004	DECAL; ERROR CODES	1.....	D25100100
25	D5551005703	DECAL; PROTECTOR	1.....	D55100570A
26	0800628504	DECAL; GROUND	1.....	S-1123
27	D5562000002	DECAL; MQ WHISPERWELD	1.....	D56200000
28	D5562100002	STRIPE	1.....	D56210000B
29	D5562100102	STRIPE	1.....	D56210010B
30	D3561000104	DECAL; MQ	3	
31	D9512100203	DECAL; CAUTION ON WELDING OPER.	1.....	D91210020A
32	D9511200803	DECAL; SMART STICK	2	
33	920214100	DECAL; WARNING START FIRES.....	1.....	M90420000 REPLACES P/N M9504200004
34	W7810680204	DECAL; COOLING WATER.....	1.....	S-3061
35	1980680004	DECAL; FUEL COCK.....	1.....	S-3704
36	8700611524	DECAL; CAUTION OIL LEVEL GAUGE	1.....	S-4926B
37	1630610404	DECAL; CAUTION FUEL FILTER.....	1.....	S-1406
38	1630610504	DECAL; CAUTION DOOR.....	1.....	S-1409
39	D5551007704	DECAL; FUEL, WATER, OIL DRAIN	1.....	D55100770
40	A9511101304	DECAL; WARNING PROPOSITION 65.....	1.....	A91110130

PARTS MANUAL

HERE'S HOW TO GET HELP

PLEASE HAVE THE MODEL AND SERIAL
NUMBER ON HAND WHEN CALLING

UNITED STATES

Multiquip Inc.

(310) 537- 3700
6141 Katella Avenue Suite 200
Cypress, CA 90630
E-MAIL: mq@multiquip.com
WEBSITE: www.multiquip.com

CANADA

Multiquip

(450) 625-2244
4110 Industriel Boul.
Laval, Quebec, Canada H7L 6V3
E-MAIL: infocanada@multiquip.com

UNITED KINGDOM

Multiquip (UK) Limited Head Office

0161 339 2223
Unit 2, Northpoint Industrial Estate, Globe Lane,
Dukinfield, Cheshire SK16 4UJ
E-MAIL: sales@multiquip.co.uk

© COPYRIGHT 2026, MULTIQUIP INC.

Multiquip Inc., the MQ logo and the MQ Power logo are registered trademarks of Multiquip Inc. and may not be used, reproduced, or altered without written permission. All other trademarks are the property of their respective owners and used with permission.

This manual MUST accompany the equipment at all times. This manual is considered a permanent part of the equipment and should remain with the unit if resold.

DISCLAIMER: Product features, descriptions, and specifications are based on published information at the time of publication and are subject to change at any time without notice. Multiquip Inc. and its affiliates reserve the right to change specifications, features, design, and descriptions of products at any time without notice.

Manufactured for
MQ Power Inc.
by
DENYO MANUFACTURING CORP.

