

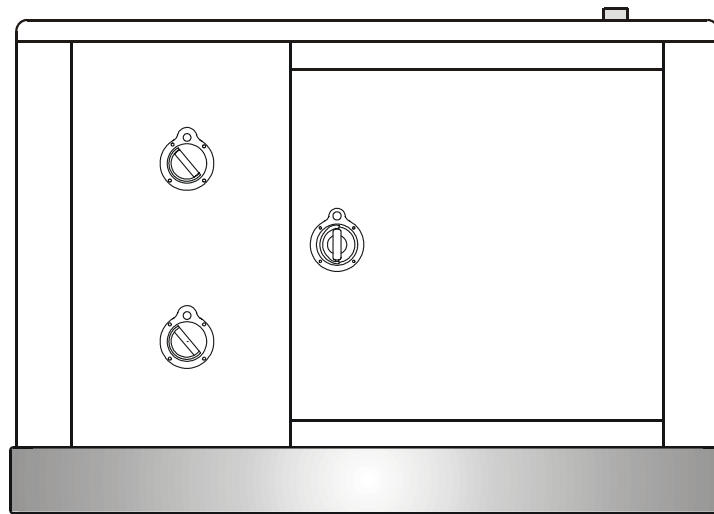

# 250 Amp Studio Generator

**On-Site Power Studio Generator Set ..... 250 Amp Diesel**

Model	Emissions	Amperage 120/208 Line to Neutral x 3
EGS250H	EPA Certified	250A
		60 Hertz



## Standard Features:

- Hatz Air-Cooled Diesel Engine
- Marathon Alternator
- Sound Attenuated Aluminum Housing with Rounded Corners
- Dual Automatic Voltage Regulators with Changeover Switch
- Led Instrument Panel - Voltage, Amperage, Hertz
- Analog Engine Gauges - Coolant Temperature, Oil Pressure, Hourmeter Battery Volts
- Camlok Outlet Panel - 1 set
- 120/240 Single Phase - 20 kW  
120/208 Three Phase - 30 kW
- Rotary Voltage Selector Switch - 2 position
- Main Line Circuit Breaker - 80 Amp
- Racor 500 Fuel/Water Filter
- Electric Priming Feature
- Crystal Sync Electronic Governor
- Internal DC Lighting with Timer
- Stainless Steel Water Lines, Exhaust Piping, Hinges and Outer Hardware
- Critical Grade Exhaust Silencer with Rain Cap



# 250 Amp Studio Generator

## APPLICATION DATA

### Alternator Specifications

Manufacturer/Model	Marathon Magnaplus, 283PSL1507
Type	4-Pole, Rotating Field
Exciter Type	Brushless, voltage regulated
Number of Leads	12 Lead
Insulation	NEMA MG1-1.66
Material	Class H
Generator RPM	1800
Power Factor	0.8
Amortisseur Windings	Full
Coupling	Single bearing, flexible
Cooling Air Volume	250 CFM
Voltage Regulation (no load to full load)	±1%
Single Step Load Acceptance per NFPA 110	100% of Rating

- Compliant with NEMA MG1-22, BS5000, CSA-C22-2, IEC-34-1 standards for temperature rise.
- Sustained short-circuit current up to 300% of rated current for up to 10 seconds.
- Drip-proof, self-venting, amortisseur windings.
- Epoxy impregnated windings with tropical insulation for increased environmental protection and long life.
- Exceptional waveshape and voltage balance; 2/3 pitch winding to minimize harmonic distortion.
- Solid-state, volts-per-hertz voltage regulator with ±1% no-load to full-load voltage regulation.

### Engine Specifications

Manufacturer	Hatz
Model, Type	4L41C direct injection, air-cooled, 4-cycle
Cylinder Arrangement	4 cylinder In-Line
Displacement	3.4 L (207.4 in <sup>3</sup> )
Bore	4.02 in. (102mm)
Stroke	4.13 in. (105mm)
Compression Ratio	18.7:1
Piston Speed	2067 ft/sec (10.5 m/s)
Cylinder Block	Grey cast iron
Cylinder Head	Light metal
Crankshaft	Nodular Iron
Brake Mean Effective Pressure (BMEP)	Consult Factory
Rated RPM	1800 RPM
Max. Power At Rated RPM (with fan)	40 hp (29.8 kw)
Governor Type	Crystal Sync Electronic
Frequency Regulation: No load to full load	Isochronous under varying loads from no load to 100% rated load
Frequency Regulation: Steady State	±0.25% of mean value for constant loads from no load to full load
Air Cleaner Type	Dry

### Amperage

Voltage	Phase	Amperage
120/240V	Single - zig zag	150A total
120/208V	Single - 4 wire	250A total
120/208V	Three	104A total

### Fuel System

Fuel Injection Pump Make	Consult Factory
Recommended Fuel	ASTM-D975/No.1 & No.2-D
Maximum Fuel Flow	Consult Factory
Fuel Filters	Spin-on type
Fuel Consumption	
Diesel Fuel At % of Load	gal/hr (L/hr)
100%	2.5 (9.5)
75%	1.9 (7.2)
50%	1.12 (4.23)
25%	0.8 (3.0)



# 250 Amp Studio Generator

## Engine Electrical System

Battery Charging Alternator Make	Valeo
Ground Type	Negative
Volts (DC)	12V
Ampere Rating	60A
Starter Motor Make/Model	Hatz
Starter Motor Rated Voltage	12VDC
Starter Motor Battery Capacity:	110 Ah

## Lubrication System

Type	Full pressure feed
System Capacity (with filter)	4.0 gal. (15.0 L)
Oil Filter	Full flow disposable
Oil Cooler	Full flow intergrated design, side mounted
Oil Pressure At Rated Speed	Manual

## GENERATOR CONTROLLER

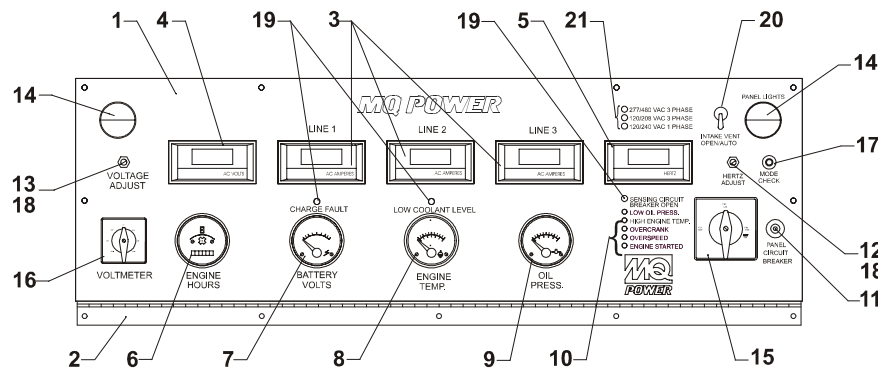

- |                            |                                  |                                   |
|----------------------------|----------------------------------|-----------------------------------|
| 1. AC Digital Panel        | 8. Water Temp. Gauge             | 15. Engine Control Switch         |
| 2. Hinge Panel             | 9. Oil Pressure Gauge            | 16. Voltage Selector Switch       |
| 3. LCD Ammeter 1000A       | 10. Engine Control Unit          | 17. Panel Light/Mode Check Switch |
| 4. LCD Voltage Meter       | 11. Panel Circuit Breaker 10 Amp | 18. Locknut Pot Shift             |
| 5. LCD Frequency Meter     | 12. Speed Adjust Pot             | 19. LED 24V DC Red                |
| 6. Hourmeter               | 13. Voltage Adjust Pot           | 20. Intake Vent Door Switch       |
| 7. Voltmeter Gauge, 24 VDC | 14. Panel Lights                 | 21. Voltage Indicator LED         |

### CONTROLLER FEATURES

- 12 or 24 Volt DC compatible.
- Individual Ammeters - L1, L2, L3
- Volt Adjusting Rheostat
- Optional kW Meter available

### ■ ECU (Engine Control Unit)

- Solid State 5-Light Engine Monitor  
 Safety Shutdown and Fault Alarm for:
- Low Oil Pressure
  - High Coolant Temperature
  - Overspeed
  - Overcrank

Backfeed to a utility system can cause electrocution and/or property damage. Do not connect to any building's electrical system except through an approved device.

*Specifications are subject to change without notice.*



# 250 Amp Studio Generator

## Generator Set Optional Features:

- 277/480 Volt Three Phase with Three Position Selector Switch
- Sub-Base Fuel Tank 100 or 200 gallons
- Exterior Lighting Package
- Analog Gauge Lighting
- Custom Paint Color
- Custom Outlet Panel
- Battery Charger
- Block Heater
- 60 Amp BATES connector
- Fire Extinguisher Box Flush Mounted in Housing Door (fire extinguisher included)
- Distribution Boxes (Pin and Sleeve, Camlok Load Centers, Base Camp Packages etc.)
- Entertainment Cable
- Auto Start Wiring

## Trailer Standard Features:

- Single Axle Trailer with 60 gallon fuel tank
- Diamond Plate Decking
- 8-Lug Chrome Wheels (5) with Chrome Center Caps and Lug Nuts
- Spare Tire
- Electric or Hydraulic Brakes
- Pintle Hitch

## Trailer Optional Features:

- Electric Jack Stand
- Alcoa Aluminum Wheels
- Line-X on A-Frame and Fenders
- Wheel Chalk Basket
- Wheel Jack Stand (Mounted on Side of A-Frame)

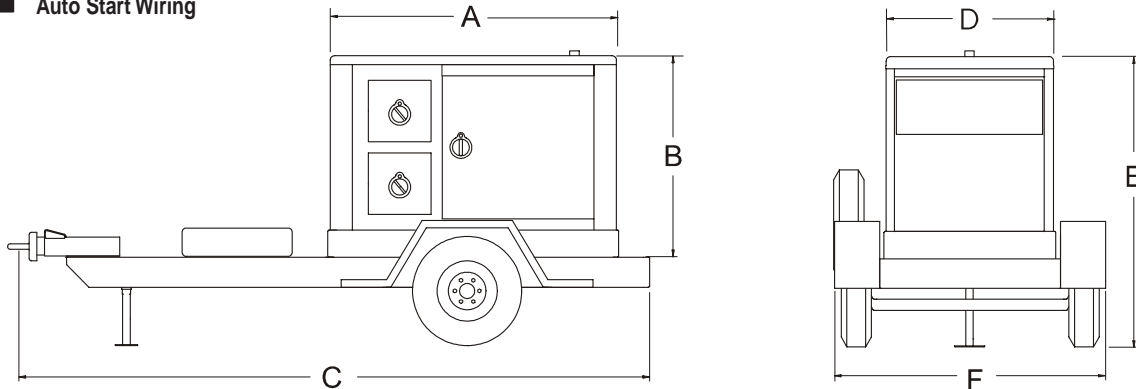

<b>Weight and Dimensions</b>						
Generator Set Dimensions with Trailer						
A	B	C		D	E	F
65 in.	45 in.	with Electric Brakes	with Hydraulic Brakes	39 in.	68.5 in.	72 in.
		160 in.	167.5 in.			
Appx. Net Weight - Generator				1200 lbs. (544 kg)		
Appx. Net Weight - Trailer				1500 lbs (680 kg)		
Trailer GVWR				6000 lbs (2722 kg)		

Your MQ Power dealer is:



**MQ POWER**  
 POST OFFICE BOX 6254  
 CARSON, CA 90749  
 310-537-3700 • 800-421-1244  
 FAX: 310-632-2656  
 E-MAIL: mqpower@multiquip.com  
 WEBSITE: www.mqpower.com