

FS2/FS2S CONCRETE SAW — WIRING DIAGRAM (ENGINE/CONSOLE)

FS2/FS2SP ELECTRIC START WIRING DIAGRAM

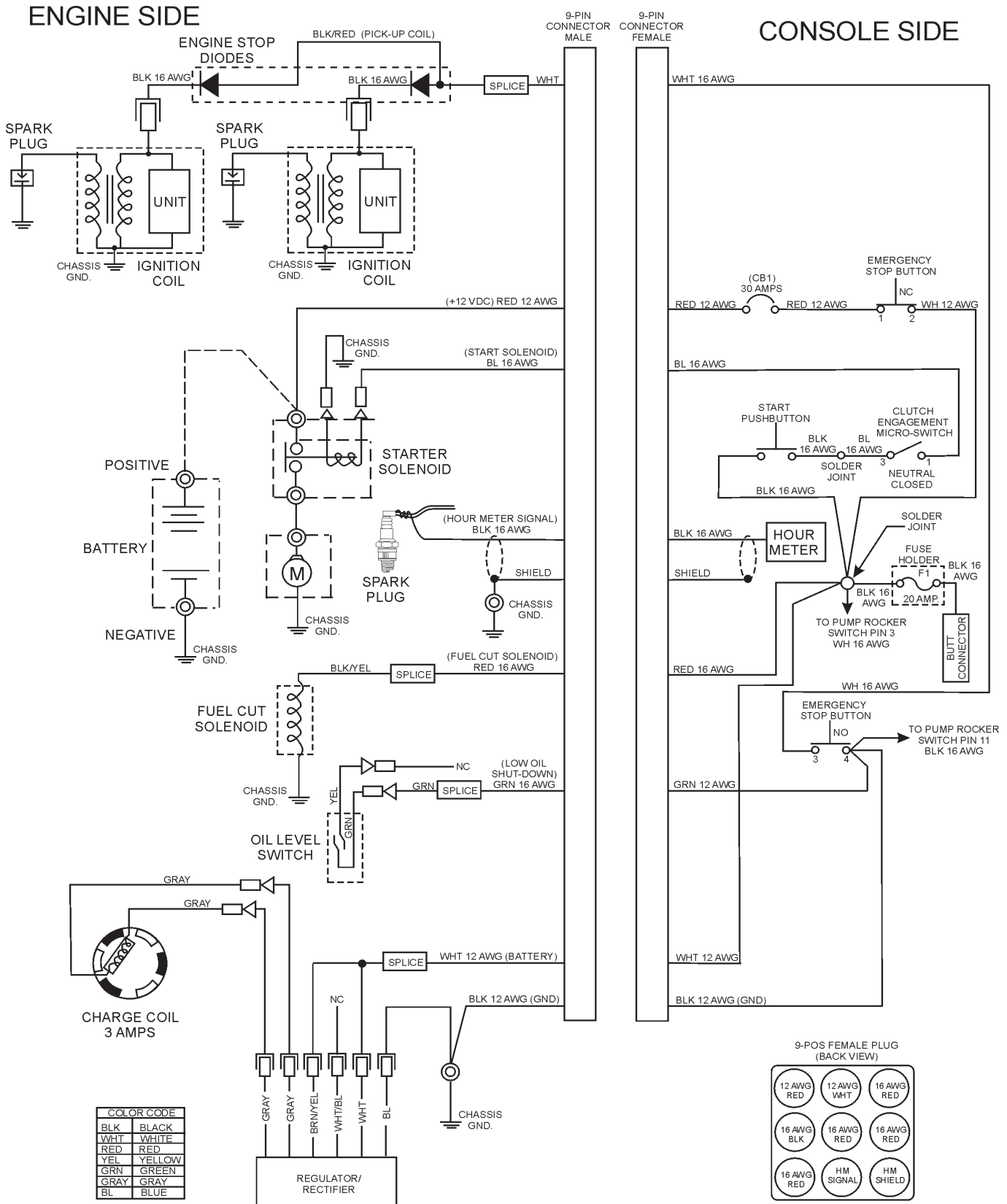

FS2/FS2S CONCRETE SAW — WIRING DIAGRAM ROCKER SWITCHES

FS2/FS2SP ELECTRIC START WIRING DIAGRAM (ROCKER SWITCHES)

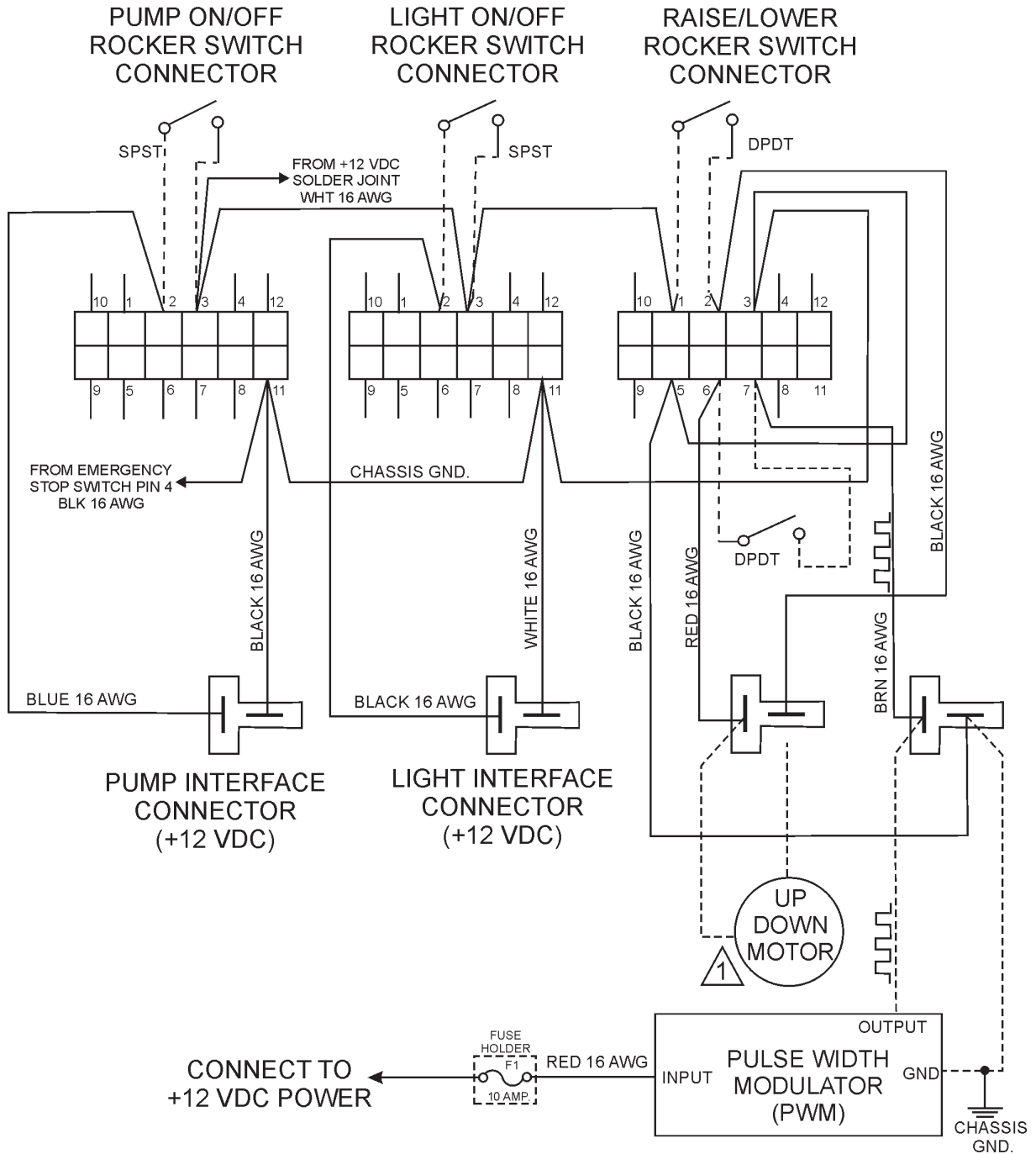

NOTES:
 THE RAISE/LOWER (CUTTING BLADE) CAPABILITY IS AN OPTION. CONTACT MULTIQUIP SALES DEPT. REGARDING THIS FEATURE.