

GA-9.7 HZ — WIRING DIAGRAM

SYMBOL	PARTS NAME
Ar	Armature Winding
Fg	Field Winding
EXW1~2	Excitation Winding
II	AC Voltmeter
Re1~5	Rectifier
CON1	Receptacle (120V/240V)
CON2	Receptacle (240V)
CON3	Receptacle (120V)
CON4~5	Receptacle (120V-GFCI)
CB	Circuit Breaker (for MAIN)
CB1	Circuit Breaker (120V/240V-30A)
CB2	Circuit Breaker (240V-20A)
CB3	Circuit Breaker (120V-30A)
CB4~5	Circuit Breaker (120V-20A)
SW1	Idle Control Switch
SW2	Operation Switch
SW3	Starter Switch
RC	Idle Control Device
S	Solenoid
Ry	Relay
F	Fuse

COLOR CODE			
CODE	WIRE COLOR	CODE	WIRE COLOR
B	BLACK	R	RED
L	BLUE	W	WHITE
BR	BROWN	Y	YELLOW
G	GREEN	LB	LIGHT BLUE
GR	GRAY	LG	LIGHT GREEN
V	VIOLET	O	ORANGE
P	PINK		

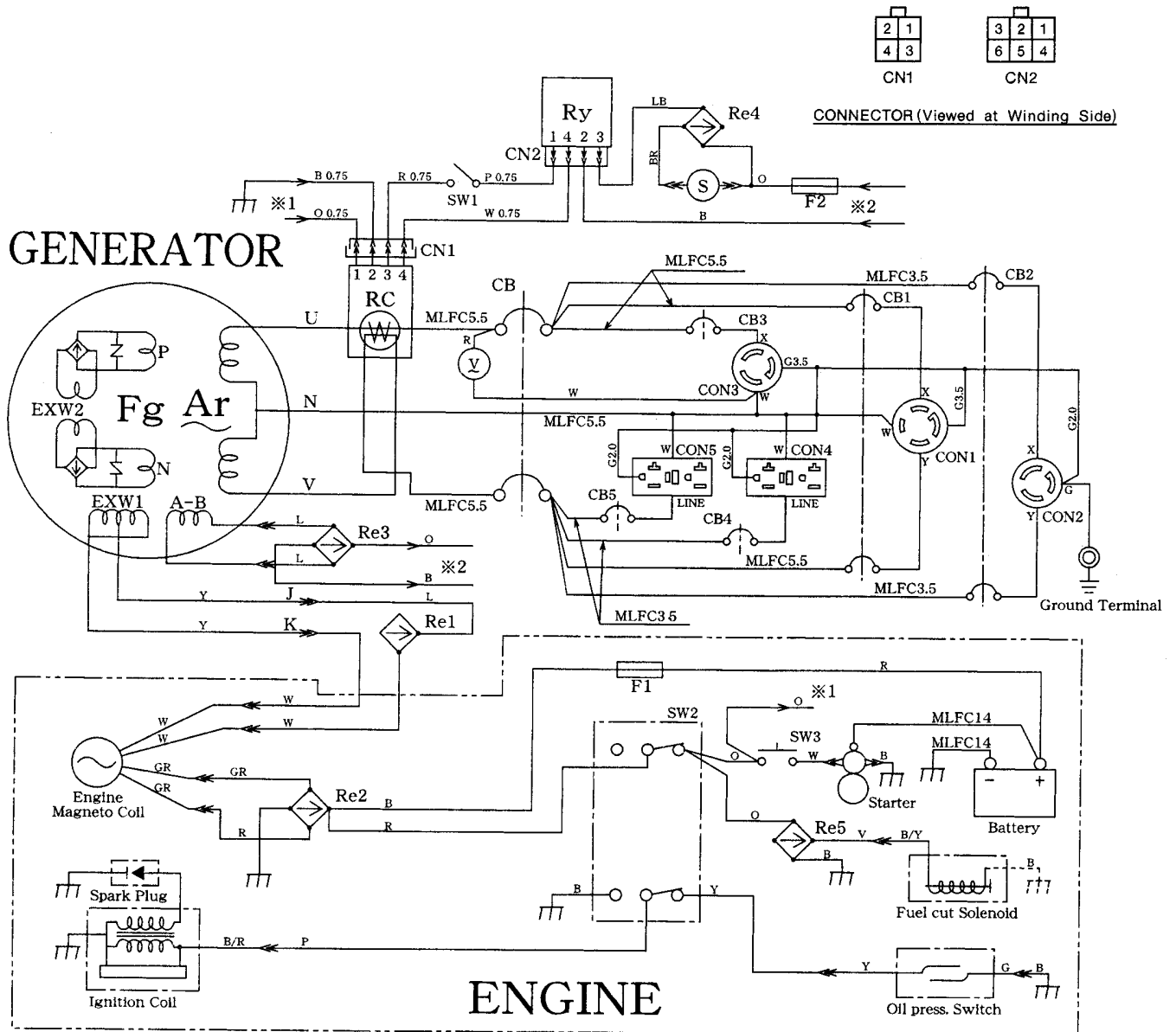

GA-9.7 HZ A.C. GENERATOR