

GB113BC LIGHTING SYSTEM - WIRING DIAGRAM

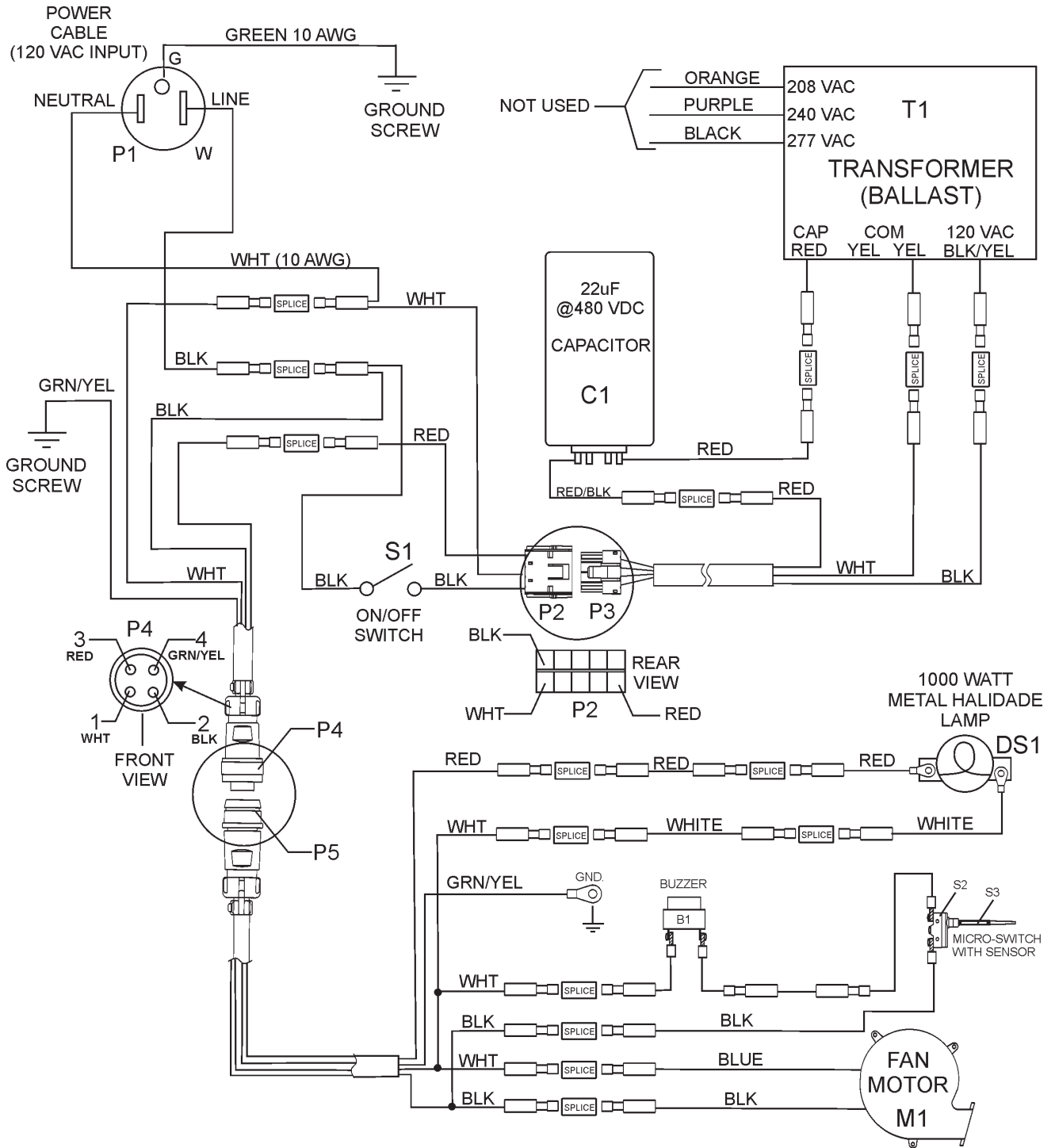

TABLE 3 REFERENCE DESIGNATIONS

REF. DESC.	DESCRIPTION	PART NUMBER	REF. DESC.	DESCRIPTION	PART NUMBER
P1	AC Power Cable Assy.	A300116300	M1	Fan Motor Assy.	A300033500
P2/P4	Ballast Cable Assy. (From S1)	A300105800	B1	Buzzer Alarm Balloon	E000030100
P3	Ballast Cable Assy. (To Transformer)	A300105600	S2	Micro-Switch	1400150210
P5	Lamp-Fan-Sensor Cable Assy.(Power)	A300105500	S3	Sensor Balloon	1400150410
S1	Single-Pole ON/OFF Switch	A400140600			
DS1	1000 Watt Metal Halide Lamp	E000009800			
C1	22 uf Capacitor @ 480 VDC	A300033800			
T1	Ballast (Transformer)	A300033800			

Wiring Diagram