

OPERATION MANUAL



GLOBUG MODEL GBBAT8BM LIGHT TOWER

Revision #0 (01/15/2026)

To find the latest revision of this publication or associated parts manual, visit our website at:
www.multiquip.com



THIS MANUAL MUST ACCOMPANY THE EQUIPMENT AT ALL TIMES.

PROPOSITION 65 WARNING



REPORTING SAFETY DEFECTS

If you believe that your vehicle has a defect that could cause a crash or could cause injury or death, you should immediately inform the National Highway Traffic Safety Administration (NHTSA) in addition to notifying Multiquip Inc. at 1-800-421-1244.

If NHTSA receives similar complaints, it may open an investigation, and if it finds that a safety defect exists in a group of vehicles, it may order a recall and remedy campaign. However, NHTSA cannot become involved in individual problems between you, your dealer, or Multiquip Inc.

To contact NHTSA, you may either call the Vehicle Safety Hotline toll-free at 1-888-327-4236 (TTY: 1-800-424-9153), go to <http://www.safercar.gov>, or write to:

Administrator
NHTSA
1200 New Jersey Avenue, SE
Washington, DC 20590

You can also obtain information about motor vehicle safety from <http://www.safercar.gov>.

TABLE OF CONTENTS

GBBAT8BM Light Tower

Proposition 65 Warning	2
Reporting Safety Defects.....	3
Safety Information	5-10
Specifications	12-13
Dimensions.....	14
Footcandle Plot.....	15
General Information.....	16
Control Panel.....	17
Components	18-19
Setup	20-22
Operation.....	23-24
Storage	25
Transporting	26
Maintenance	27-35
Troubleshooting	36-40
Light Wiring Diagram.....	41
Cart Wiring Diagram.....	42
Control Box Wiring Diagram.....	43

DISCLAIMER:

Product features, descriptions, and specifications are based on published information at the time of publication and are subject to change at any time without notice. Multiquip Inc. and its affiliates reserve the right to change specifications, features, design, and descriptions of products at any time without notice.

SAFETY INFORMATION

Do not operate or service the equipment before reading the entire manual. Safety precautions should be followed at all times when operating this equipment. Failure to read and understand the safety messages and operating instructions could result in injury to yourself and others.

SAFETY MESSAGES







The four safety messages shown below will inform you about potential hazards that could injure you or others. The safety messages specifically address the level of exposure to the operator and are preceded by one of four words: **DANGER**, **WARNING**, **CAUTION** or **NOTICE**.

SAFETY SYMBOLS

 DANGER
Indicates a hazardous situation which, if not avoided, WILL result in DEATH or SERIOUS INJURY .
 WARNING
Indicates a hazardous situation which, if not avoided, COULD result in DEATH or SERIOUS INJURY .
 CAUTION
Indicates a hazardous situation which, if not avoided, COULD result in MINOR or MODERATE INJURY .
NOTICE
Addresses practices not related to personal injury.

SAFETY SYMBOLS

Potential hazards associated with the operation of this equipment will be referenced with hazard symbols which may appear throughout this manual in conjunction with safety messages.

Symbol	Safety Hazard
	Lethal exhaust gas hazards
	Explosive fuel hazards
	Burn hazards
	Overspeed hazards
	Rotating parts hazards
	Pressurized fluid hazards
	Electric shock hazards

SAFETY INFORMATION

GENERAL SAFETY

CAUTION

- **NEVER** operate this equipment without proper protective clothing, shatterproof glasses, respiratory protection, hearing protection, steel-toed boots and other protective devices required by the job or city and state regulations.



- **NEVER** operate this equipment when not feeling well due to fatigue, illness or when under medication.
- **NEVER** operate this equipment under the influence of drugs or alcohol.

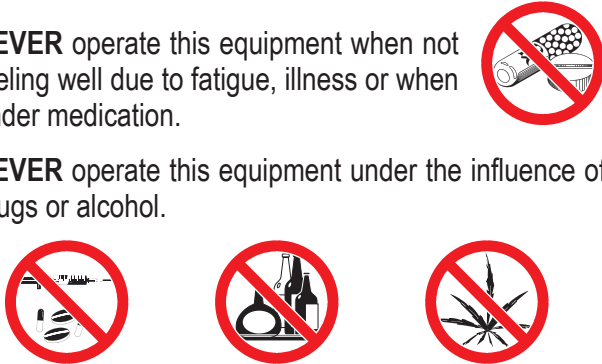

- **ALWAYS** check the equipment for loosened threads or bolts before starting.
- **DO NOT** use the equipment for any purpose other than its intended purposes or applications.

NOTICE

- This equipment should only be operated by trained and qualified personnel 18 years of age and older.
- Whenever necessary, replace nameplate, operation and safety decals when they become difficult read.
- Manufacturer does not assume responsibility for any accident due to equipment modifications. Unauthorized equipment modification will void all warranties.
- **NEVER** use accessories or attachments that are not recommended by Multiquip for this equipment. Damage to the equipment and/or injury to user may result.

- **ALWAYS** know the location of the nearest **fire extinguisher**.
- **ALWAYS** know the location of the nearest **first aid kit**.



- **ALWAYS** know the location of the nearest phone or **keep a phone on the job site**. Also, know the phone numbers of the nearest **ambulance**, **doctor** and **fire department**. This information will be invaluable in the case of an emergency.

SAFETY INFORMATION

LIGHT TOWER SAFETY

DANGER

- **NEVER** operate the equipment in an explosive atmosphere or near combustible materials. An explosion or fire could result causing severe



CAUTION

- **NEVER** lubricate components or attempt service on a running machine.
- **ALWAYS** ensure light tower is on level ground before use so that it cannot slide or shift around, endangering workers. Always keep immediate area free of bystanders.
- **ALWAYS** make sure trailer is leveled with all outriggers extended before raising tower. Outriggers must remain extended while tower is up.
- **ALWAYS** keep area behind trailer clear of people while raising and lowering mast.
- **NEVER** remove safety pin or pull mast locking pin while tower is in a raised position!
- **CHECK** the mast and winch cables for wear. If any problem occurs when lowering or raising the tower, STOP immediately! Contact a trained technician for assistance.
- **NEVER** pivot or retract mast while unit is operating.
- **NEVER** use the light tower mast as a crane. **DO NOT** lift anything with the mast.
- **ALWAYS** lower the light tower when not in use, or if high winds or electrical storms are expected.
- To prevent falls, always use outriggers and lock them in place. There is a risk of tipping in strong winds or without a battery. The overturning risk varies according to the setting and conditions. For extra safety, use a rope and blocks to steady the light tower.
- Please pay close attention to your feet during installation.
- Tighten the knob properly. If the knob is loose, the lamp or mast may fall, resulting in injury or damage.
- When storing and folding the mast, **ALWAYS** keep hands and fingers away from pinch points.

NOTICE

- **ALWAYS** keep the immediate area surrounding the light tower clean, neat, and free of debris.
- **ALWAYS** keep the machine in proper running condition.
- Fix damage to machine and replace any broken parts immediately.
- **ALWAYS** store equipment properly when it is not being used. Equipment should be stored in a clean, dry location out of the reach of children and unauthorized personnel.
- To prevent the light tower from overturning, **NEVER** use in winds that exceed **45 MPH (72 km/h)**.

LAMP SAFETY

WARNING

- **NEVER** attempt to replace lamp with the power on. Always shut down the power when changing the lamp.

CAUTION

- **NEVER** use force when installing the lamp. Excessive force could cause the lamp to break, causing bodily harm.
- **DO NOT** cover the lamp with cloth.

NOTICE

- **ALWAYS** make sure lamp surface is clean and dry.
- **ALWAYS** replace with MQ recommended type lamp.
- **ALWAYS** have a **trained technician** install and remove a lamp, or replace any damaged fixture wiring.

SAFETY INFORMATION

BATTERY SAFETY

DANGER

- **DO NOT** remove or install the battery if you are not fully familiar with the handling methods and hazards of the battery. Improper handling may result in a serious accident.
- **DO NOT** touch the battery electrodes, power plug, or terminals. Failure to do so may result in serious accidents due to electrical leakage or other equipment malfunctions or electric shock.
- Reverse connection may cause a short circuit inside the battery, resulting in battery damage, fire or burns.

WARNING

- Touching more than one battery electrode at a time may cause an electric shock and a serious accident. Also, touching two or more electrodes with a wrench or other tools may cause electric shock or sparking, which may ignite the battery.
- Since the battery is heavy, handle carefully. There is a risk of injury from dropping it.
- Climbing on or placing objects on the battery cover may cause injury or damage.
- Use of a dry cloth may cause ignition and explosion due to static electricity. Always use a tightly wrung-out wet cloth for cleaning.

CAUTION

- A strong shock may damage the battery, resulting in electric shock, smoking or ignition.
- If smoke or fire from the battery is detected, leave the area and call help immediately.
- **DO NOT** use this product near fire, electrical sparks, or heat sources such as grinders. Doing so may cause fire or burns.
- **DO NOT** use or perform maintenance in rain, snow, splashing water, or dust. Also, do not operate the product in a puddle of water. Doing so may result in damage, electrical leakage, or fire.

- Leaving waste batteries unattended may cause serious accidents due to ignition caused by residual energy.
- The battery cover may become hot depending on the ambient environment, and touching it with bare hands may cause burns. Use caution when touching the battery cover.
- Store in a cool, dark, well-ventilated place out of direct sunlight, avoiding high temperature, high humidity, and fire.

NOTICE

- **ALWAYS** recharge the battery within one week after use.
- Excessive screw tightening may damage the terminals.
- Replace the battery when the lead wires or terminals are corroded.
- Failure to replenish electricity during storage will accelerate deterioration.
- Leaving the battery with a low level of power may damage or degrade the battery.
- When storing for long periods of time, please replenish the batteries once every three months.
- If left discharged for a long period of time, the protection circuit will be activated and the battery cannot be recharged.

SAFETY INFORMATION

TRANSPORTATION SAFETY — LIGHT TOWER

CAUTION

- **DO NOT** use floodlights or battery during transportation.
- During transportation, please be cautious and make sure your feet do not get caught in the tires.
- Before transporting the light tower, make sure to fold down the lighting unit, lock the fold lever.
- When transporting by a vehicle, ensure that the four jack stands are positioned to permit their foot bases even contact with the deck floor. Secure it with a rope, or appropriate fasteners. The light tower may be damaged or may fall, resulting in a serious accident.
- To avoid the risk of losing balance and falling over, always retract the mast when in motion.
- Transporting the light tower while the mast extended could collide with overhead obstructions. Contact with overhead power lines or other obstructions could result in equipment damage, electrical shock, electrocution and even death.
- To ensure safety, remember to secure the light tower properly during transportation by vehicle. If not secured, the light tower may move out of control and cause harm.
- Trying to manually move the light tower up a slope could result in the tower losing control and causing a dangerous accident.
- To avoid potential accidents, it is not recommended to manually move the light tower on a steep slope where it may be difficult to control. Instead, transport the unit to the installation site by vehicle.
- Be cautious when loading and unloading on slopes or unstable surfaces as it may cause the light tower to fall and cause damage or injury.
- To prevent damage or injury, it is important to take precautions when releasing the brake of the light tower.
- It is important to note that if the brake is released, the light tower may move due to its weight and potentially fall, causing harm or damage.

- Always use wheel chocks and jack up the light tower before releasing the brake. Additionally, keep an eye on the movement of it during work to ensure safety.
- Unloading work must be done on a flat surface.
- **NEVER** lift up the light tower at any points except the specified one. Using other points could result in bodily injuries.
- Ensure that the light tower is properly balanced before attempting to lift it.
- Lower the mast fully when moving or lifting the light tower. Failure to do so could cause the wire to come off or the light tower to be overturned and result in injuries.
- Do not lift light tower in strong winds.
- When transporting on a steep slope, ensure the light tower is secure and will not run out of control. Additionally, be aware of the danger while transporting on such terrain. Please take the necessary precautions to prevent accidents.

NOTICE

- **ALWAYS** tighten the adjust lever and the bolt firmly and make sure that the lamp stand is fixed to the mast before transporting the light tower, to prevent it from falling down or being damaged in transport.
- A strong impact could damage the lamp and shorten the product life significantly. Be careful when moving, transporting, loading and unloading.

SAFETY INFORMATION

ELECTRICAL SAFETY

DANGER

- **NEVER** operate light tower or handle any electrical equipment while standing in water, while barefoot, while hands are wet. A dangerous **electrical shock** could occur, causing **severe bodily harm or even death**.
- **ALWAYS** make sure the area above the light tower is open and clear of overhead power lines and other obstructions. The tower extends in excess of 20 feet (6 meters). Contact with overhead power lines or other obstructions could result in equipment damage, **electrical shock, electrocution and even death**.
- Similar to boom equipment, light tower may become energized with high voltage. **DO NOT** operate the light tower within a radial distance of 17 feet (5.1 meters) from high voltage power lines. If light tower becomes energized with high voltage, contact with the equipment could result in electrocution.
- **NEVER** operate light tower in winds in excess of **45 MPH**.
- There is a ground connection terminal to the light tower. **ALWAYS** check with state, district and municipalities for electrical grounding requirements before using equipment. Reference NEC Article 250.

ENVIRONMENTAL SAFETY

NOTICE

- Dispose of hazardous waste properly. Examples of potentially hazardous waste are used motor oil, fuel and fuel filters. 
- **DO NOT** use food or plastic containers to dispose of hazardous waste.
- **DO NOT** pour waste, oil or fuel directly onto the ground, down a drain or into any water source.

SPECIFICATIONS

Table 1. Light Tower Specifications		
Model		GBBAT8BM
Light Tower	Voltage	120 VAC
	Frequency	50 / 60 Hz
	Wattage	Single Charging: 1380 W / Dual Charging: 2760 W
	Wind Stability	34 mph (15 m/s)
	Run Time ^{*2,3}	12 h (800W) 16 h (600W) 24 h (400W)
	Recharging Time ^{*3,4,5,6}	11 h (with 1 charger) 5.5 h (with 2 chargers)
Lamp	Type	LED / Balloon
	Dimming	800/600/400 Watts
	Watts x Pcs.	800 x 1
	Luminous Flux (each lamp)	110,000, 90,000, 67,000 lm ^{*1}
	Lamp Life	40,000 hours
	Ambient Temperature	14 to 104°F (-10 to 40°C)
Mast	Type	4-Stage Telescopic (with safety stopper)
	Operation Method	Manual
Cart	Type	Front Tires: Outer diameter 13.8" Solid x 2 Rear Casters: Outer diameter 7.9" Solid x 2
	Tire Inflation Pressure	N/A
	Parking Brake	Rear Caster Brake x 2
	Outrigger	Front & Rear Pull-out Type x 4 (Standard equipped)
	Jack	4 (Standard equipped)
Dimensions	Working	92.5 x 61.8 x 105.5 to 252 in (2350 x 1570 x 2680 to 6400 mm)
	Stowed	46.5 x 30.7 x 82.7 in (1180 x 779.880 x 2100 mm)
Weight	Operating	817.9 lb (371 kg)

SPECIFICATIONS

Battery	Voltage	48 to 58.2 VDC
	Capacity	230 Ah
	Weight	223 lb
Charger	Input Voltage	100 to 240 VAC
	Power Consumption	1380 W (with 1 charger) 2760 W (with 2 chargers)
Inverter	Output Voltage	120 V
	Output Frequency	50/60 Hz
	Rated Output Power	1500 W
	Output Terminal	N/A

**1 Maximum value. Due to variability in manufacturing process of LED chips, luminance and light temperature may differ by units.*

**2 Battery capacity gradually decreases with number of uses and aging of time. Depending on environment in use, run time and recharging time may vary.*

**3 When the battery goes down to remaining power to light up for one hour, lights automatically dim from 300W or 180W to 100W.*

**4 Below/over 104° F, recharging time may lengthen.*

**5 Below 14° F, recharging time may lengthen.*

**6 When use of two inlets (chargers), connect to power line of 30A or more, or connect to two power lines (separate lines).*

DIMENSIONS

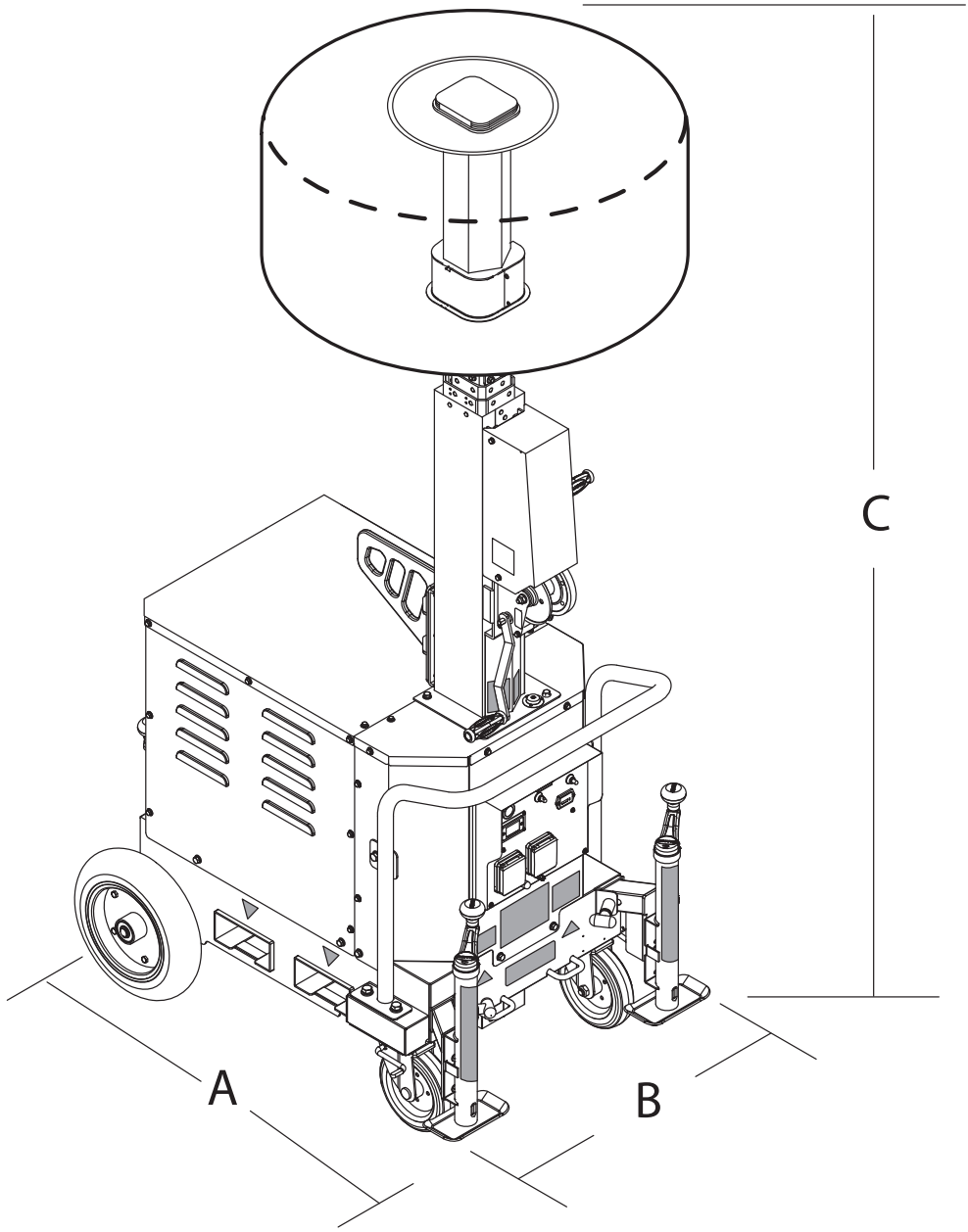
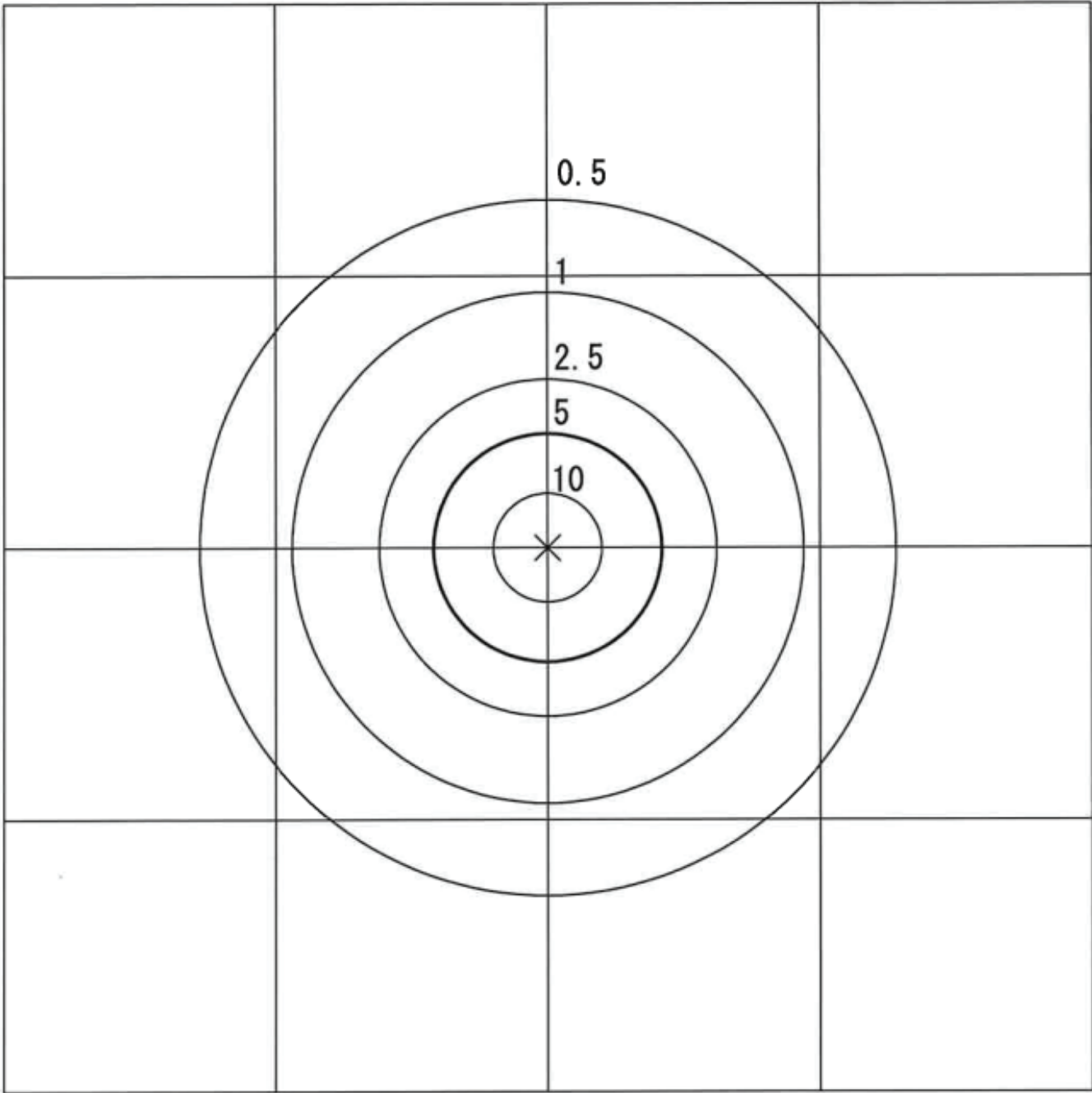

Figure 1. GBBAT8BM Dimensions

Table 3. GBBAT8BM Dimensions	
Reference Letter	Dimension in. (mm)
A	92.5 (2349.5)
B	61.8 (1569.7)
C	105.5 to 252 (2679.7 to 6400.8)

FOOTCANDLE PLOT



1 scale=50ft

footcandle	30	20	10	5	2.5	1	0.5
ft (From the installation point)	-	-	10	21	31	47	64

Figure 2. Footcandle Plot

GENERAL INFORMATION

The Multiquip model GBBAT8BM is an 800W balloon battery type, mobile light tower that provides exceptional clear lighting for multiple applications found in construction, emergency response, special events, security, and general large projection lighting challenges.

The GBBAT8BM utilizes one 800W lamp that can withstand high impact and inclement weather. The lamp assembly has a service life of 40,000 hours; and at full power, projects 110,000 lumens.

The unit is supported by a cart that provides 4 adjustable jack stands. A four-stage, telescopic mast assembly raises to a maximum height of 20 feet and comes with a safety stopper to prevent accidents.

Other features of the light tower are:

- Low Level Notification and Auto dimming. When battery level is running low, Lamps flush and the system dims lights automatically.
- Battery Error Notification. When an error occurs on the battery, panel lamp flashes (e.g. overvoltage, undervoltage, low temperature, high temperature, etc.)

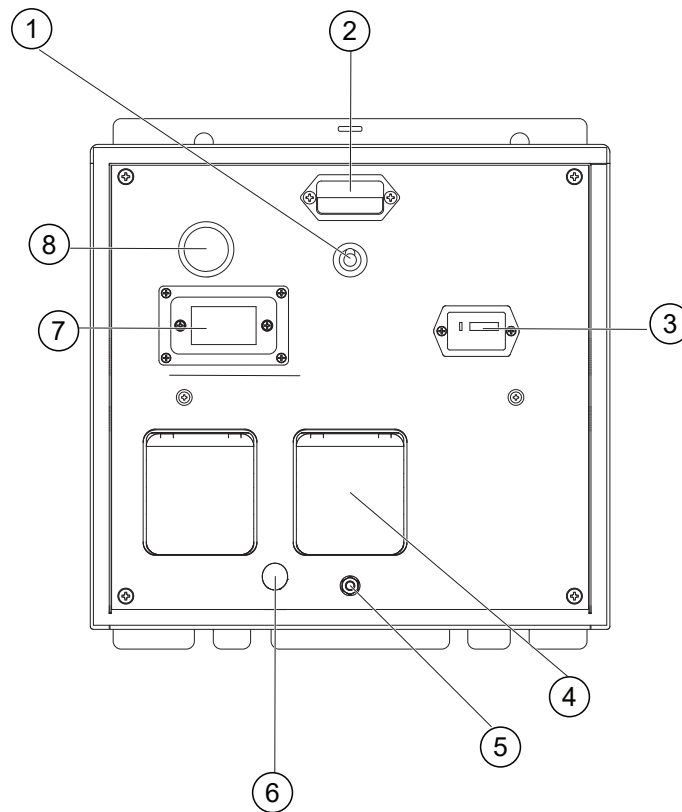

Figure 3. GBBAT8BM Control Panel

1. **Lamp Switch (Upper)** — When pressed, turns the lamps on or off.
2. **Panel Lamp** — Indicates battery error; flashes rapidly for overvoltage, flashes 3 times for communication error and blinks twice for temperature error.
3. **Hour Meter** — Indicates the number of hours that the light tower has been in use.
4. **Inlet (15A x 2)** — Connects charger to battery. Two chargers can be used at a time.
5. **Ground Terminal** — Connect earth ground to this connection point if required.
6. **Outlet Breaker** — 15A circuit breaker protects outlet from overload. When there is an overload, breaker does not work. When problem is corrected, press the breaker to reset.
7. **Battery Gauge** — Indicates the battery charge.
8. **Power Switch** — Turns the power ON or OFF.

COMPONENTS

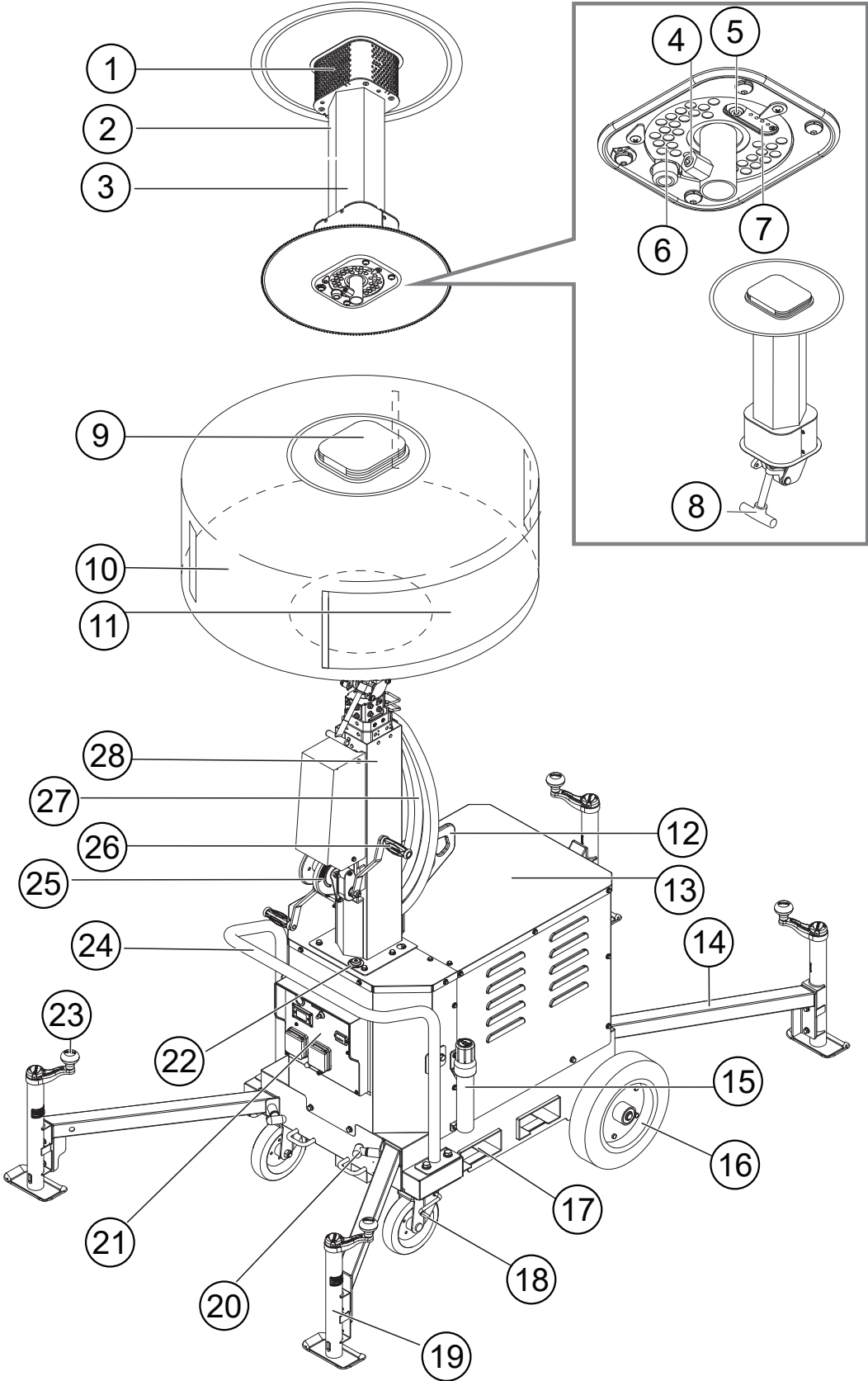

Figure 4. GBBAT8BM Components

COMPONENTS

Refer to Figure 4 for the location of the components listed below.

1. **Fan Motor** — Responsible for inflating balloon.
2. **Lamp Guard** — Industrial grade, impact and weather resistant shell enclosure.
3. **Lamp** — 800 Watt LED lamp.
4. **Set Screw** — Secures light assembly.
5. **Dimmer Switch** — At start up, lamp is lit at 800W. Pressing the dimmer switch changes the brightness in the following sequence:
800W — 600W — 400W — OFF — 800W
6. **Filter** — Prevent dust, powder, or other small particles from entering the interior of the lamp structure
7. **Indicator Lamp** — The corresponding LED indicator lamp lights depending on the brightness selected by the dimmer switch.
8. **Adjust Lever** — Adjusts the ballon position.
9. **Protective Cover** — Is a zippered, red vinyl bag that covers the 800 W Lamp. It collapses and secures atop the unit when setting up for operations.
10. **Balloon Cloth** — Encloses the lamp.
11. **Message Strip** — Optional message strip connected to the balloon coth bag with Velcro strip (contact MQ Sales Departmlet for information).
12. **Main Lamp Power Cable Hanger (Lifting Eye)** — Use this center of gravity lifting point when required to transport the unit via a supportive chain or strap. **NEVER** stand underneath the GBBAT8BM while it is being lifted.
13. **Rear Cover** — Lockable and provides immediate access to battery.
14. **Outrigger** — Should always be deployed and locked in place during operation.
15. **Manual Holder** — A cannister where operation manual is kept.
16. **Tire** — Light tower utilizes two front tires with outer diameter of 13.8" (solid x 2). Rear casters with outer diameter of 7.9" (solid x 2). Replace with recommended type tire only.
17. **Forklift Pockets** — For the ease of light tower transportation via a forklift.
18. **Caster Brake** — Locks the rear casters in place to prevent cart from moving.
19. **Jackstand** — Three jackstands and outrigger assemblies are provided to properly secure the unit including on uneven surfaces and to withstand windy operating conditions.
20. **Locking Pins** — These pins must be securely in place once the jackstands are positioned to ensure the overall security of the jackstands and outrigger sections
21. **Control Panel** — The singular control station to start/ stop the engine, monitor the engine safeguards, view the hour meter, adjust the lamp stand position, and access the main circuit breakers.
22. **Level** — Makes sure cart is level for operation.
23. **Crank Handle** — Adjusts the jack stand to lift or lower it to make thelight tower level.
24. **Handle** — Used to push cart forward or pull backwards.
25. **Mast Winch** — A self-locking, mechanical hoist that controls the mast sections to effectively raise and lower the entire assembly. Always be on the lookout for overhead obstructions. Keep immediate area free of bystanders and debris when raising the mast.
26. **Winch Handle** — Opposing operating handles that controls the mast sections in travel.
27. **Cable** — Connects the lamp assemblies to the power output.
28. **Mast** — 4-stage telescopic mast assembly that is mechanically raised to a maximum height of 23 feet.
29. **Zipper** — Zips up balloon to completely close it when lamp is in place.

CASTER BRAKE

1. Push down both sides of the caster brakes to lock (Figure 5).

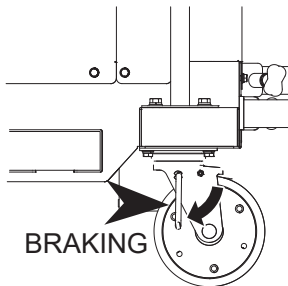

Figure 5. Locking Caster Brakes

2. To release, push up both sides of the caster brakes (Figure 6).

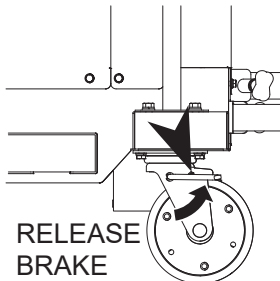

Figure 6. Releasing Caster Brakes

! DANGER

When parking on a sloping road or ground, be sure to use stoppers such as stones or blocks for the wheels and applying the brake lock as well. Without them, the light tower could move and cause accidents or injuries.

OUTRIGGERS AND JACKSTANDS

1. Place the light tower in an area free of dirt and debris with enough clearance as not to interfere with any overhead obstructions. Make sure it is on secure level ground with chock blocks underneath each wheel to prevent the light tower from rolling.

! DANGER

ALWAYS make sure the area above light tower is open and clear of overhead power lines and other obstructions. The tower extends in excess of 23 ft. (7 meters). Contact with overhead power lines or other obstructions could result in equipment damage, serious injury or death!

2. Extend all the outriggers by pulling the locking pin on the outriggers and hold while sliding out the outriggers assembly (Figure 7).

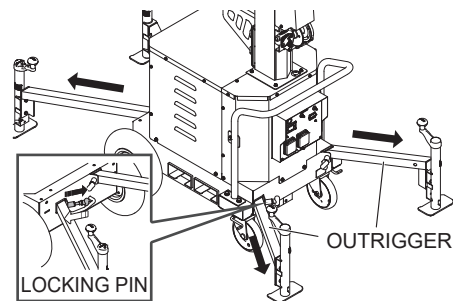

Figure 7. Extending Outriggers

3. As soon as the locking pin clears the travel position hole, release pin and continue sliding out the outrigger. When outrigger is in the extended position, make sure pin snaps into the outrigger locking hole (Figure 7).
4. After extending all outriggers, rotate all trailer jackstands into the foot-down position (Figure 8).

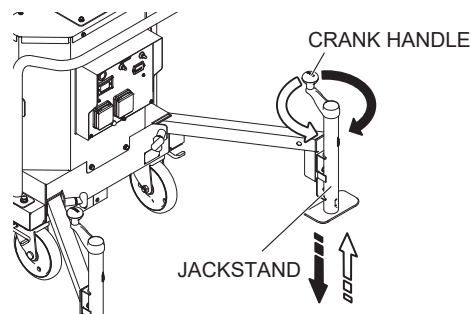

Figure 8. Positioning Jackstands

5. After extending all outriggers, place all trailer jackstands into working position. Turn the crank handle on the jack stand clockwise to lower it and level the light tower (Figure 9).

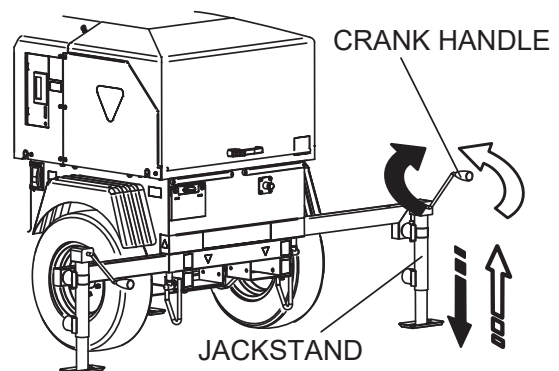

Figure 9. Lowering the Jackstands

ADJUSTING LAMP POSITION

1. Loosen the adjust lever at the bottom of the balloon light assembly (Figure 10).

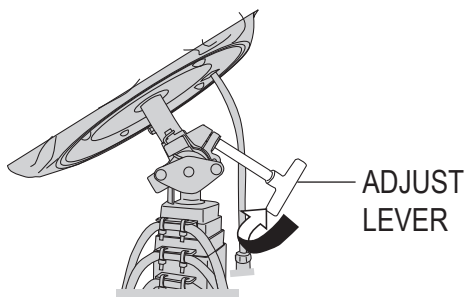

Figure 10. Loosen Adjust Lever

2. Place both hands on the balloon light assembly and slowly tilt the adjust lever to the desired position (Figure 11).

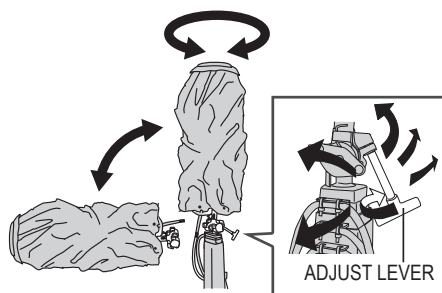

Figure 11. Tilting Balloon to Desired Position

CAUTION

Adjust the angle of the balloon light assembly only when it is securely placed on the mast. Be careful of the rotating part to avoid pinching your hands.

3. After adjustment, tighten the adjust lever (Figure 12).

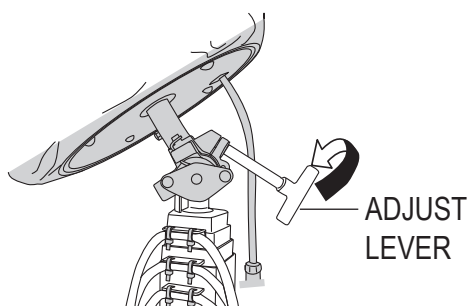

Figure 12. Tighten Adjust Lever

CAUTION

Once the necessary adjustments, have been made, make sure to tighten the adjust lever securely.

Failure to do so may result in the LED lamp falling off and causing serious harm.

ADJUSTING LIGHT TOWER HEIGHT

DANGER

ALWAYS make sure the area above light tower is open and clear of overhead power lines and other obstructions. The tower extends in excess of 23 ft. (7 meters). Contact with overhead power lines or other obstructions could result in equipment damage, serious injury or death!

CAUTION

ALWAYS make sure the trailer is on level ground with the outriggers fully extended before extending the mast. The outriggers must remain fully extended while the mast is extended.

1. Turn the winch handle to raise or lower the mast (Figure 13).
2. Turn the winch handle clockwise to raise the mast.
3. Turn the winch handle counterclockwise to lower the mast.

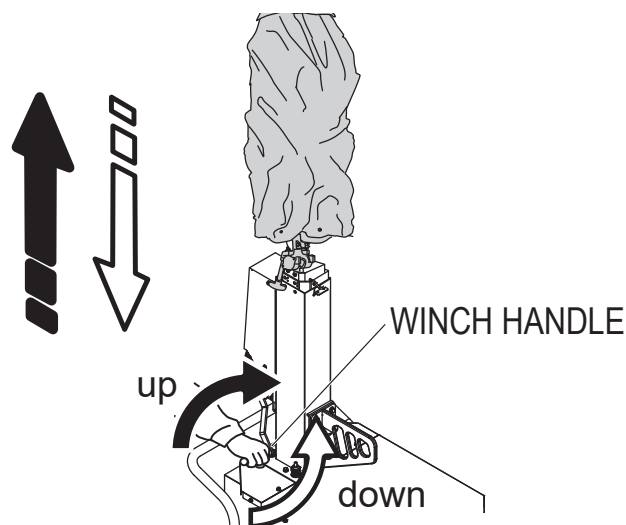

Figure 13. Raising and Lowering Mast

PUSHING CART UP A STEP

1. To safely climb up a step with the light tower, make sure that the tire side is in the front and caster side is in the rear (Figure 14).
2. Carefully push the cart forward.

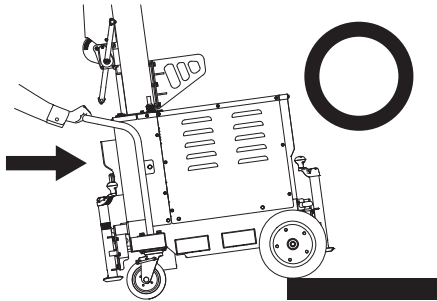

Figure 14. Moving Cart Up a Step

LIFTING THE LIGHT TOWER

1. Three lifting points are available with the cart (Figure 15).

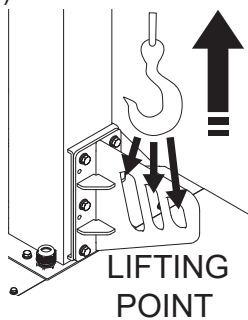

Figure 15. Lifting Point

2. Use the most suitable lifting point to achieve proper weight distribution of the cart.

MAKING SURE CART IS LEVEL

1. When adjusting the outriggers of the cart, make sure that the air bubble is in the middle of the level (Figure 16).

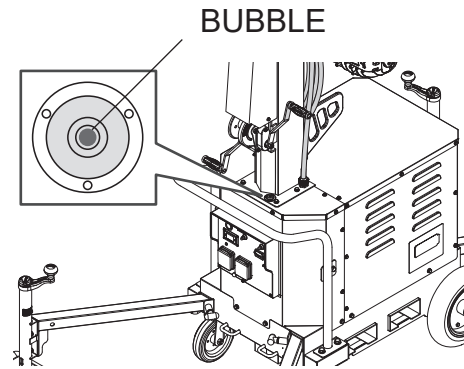

Figure 16. Cart Level

BALLOON COVER REMOVAL

2. Detach the velcro from the balloon cover and unzip cover (Figure 17).

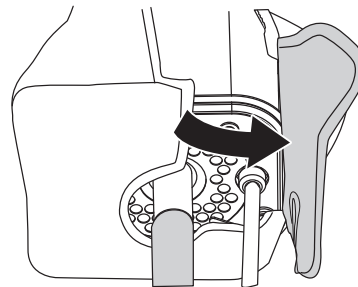

Figure 17. Balloon Cover Removal

3. Fold the protective cover into itself and zip (Figure 18).

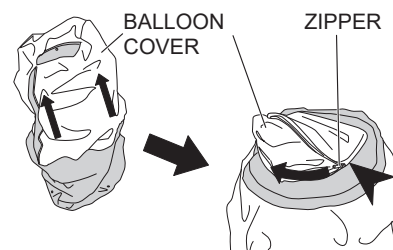

Figure 18. Zipping Protective Cover

BATTERY ACTIVATION

1. Press and hold the power switch for three seconds. The panel lamp lights for 1 minute (Figure 19).

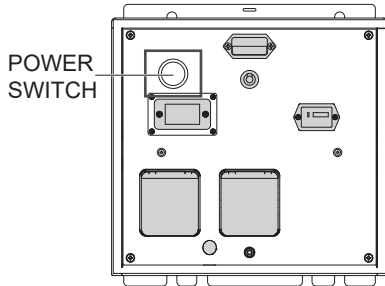

Figure 19. Battery Activation

TURNING ON THE LAMP

1. Turn on the lamp switch (Figure 20).

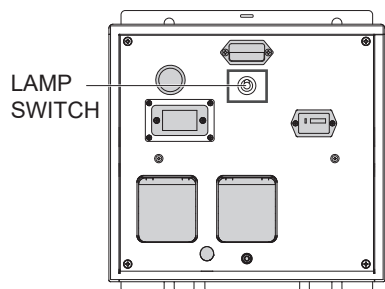

Figure 20. Turning On Lamps

NOTICE

The power is automatically turned off when not used for 60 minutes.

DIMMING THE LAMP

1. Press the dimmer switch to change the brightness of the lamp (Figure 21). The lamp starts at 800 W.
2. Press the dimmer switch to control the brightness. The lamp can be turned off or set to 400 W, 600 W, or 800 W. The corresponding LED indicator of the selected brightness will light red.

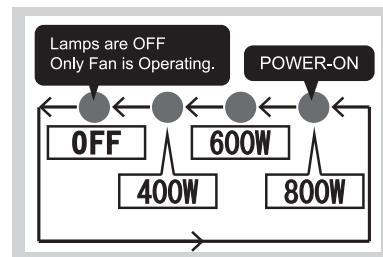
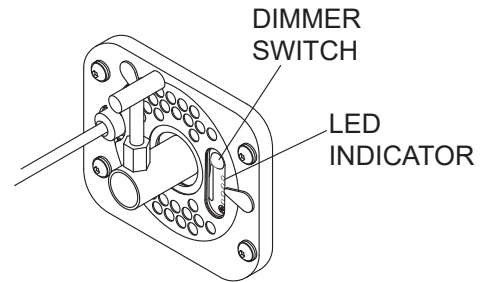

Figure 21. Dimming the Lamps

3. The operation time of the lamps will depend on the selected brightness (Table 4).

Table 4. Lamp Brightness

Brightness	Operation Time* (Fully Charged)
800 W	12 hours
600 W	16 hours
400 W	24 hours

* The operation time is an estimate (includes automatic dimming).

SILENT MODE

1. To eliminate the noise coming from the unit during operation, press and hold the dimmer switch for 3 seconds (Figure 22).

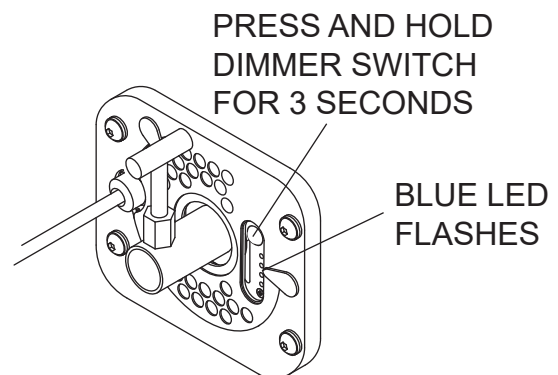

Figure 22. Turning On Silent Mode

OPERATION

2. The Blue LED on the center of the switch flashes in the silent mode.
 3. The silent mode works only in 400W operation.
 4. To switch back to normal mode, press and hold the dimmer switch for 3 seconds. The blue LED will stop flashing.
 5. When unit restarts, it reverts to the normal mode even if the silent mode was selected prior to shutdown.
2. Press and hold the power switch for three seconds to turn off the battery (Figure 25).

BATTERY ERROR

Panel lamp (Figure 23) blinks to indicate when there is a battery error as follows:

1. **Overvoltage** - Panel lamp blinks rapidly. Turn off battery and wait for a few minutes before restarting.
2. **Communication Error** - The panel lamp blinks three times. See Troubleshooting for details.
3. **Temperature** - Panel lamp blinks twice. Check the ambient temperature.

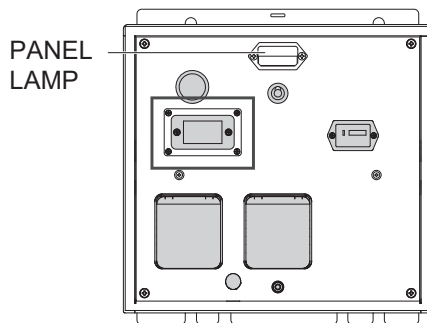

Figure 23. Panel Lamp

TURNING LAMPS OFF

1. Turn off the lamp switch (Figure 24).

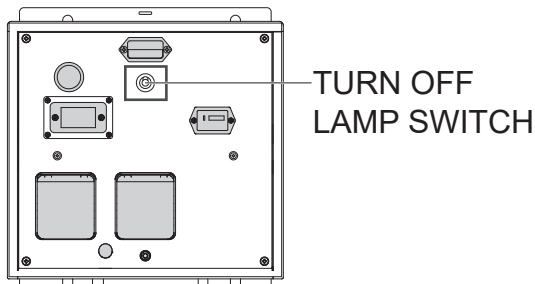

Figure 24. Lamp Switch OFF

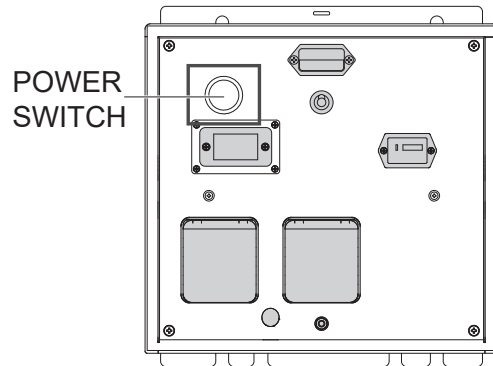

Figure 25. Power Switch OFF

PREPARATION FOR STORAGE

WARNING

The lamp portion is hot during lighting and immediately after turning off. Please allow the lamps to cool down sufficiently before working on them to avoid the risk of burns.

CAUTION

During operation of the lever, please be careful not to pinch your fingers.

1. Loosen the adjust lever (Figure 26). With your hands on the lamp, carefully tilt the adjust lever diagonally upwards. This will position the balloon light assembly horizontally.
2. Tighten the adjust lever to secure in place.

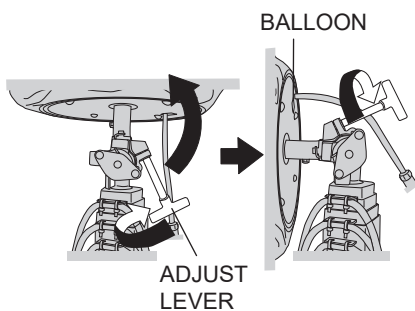

Figure 26. Loosen Adjust Lever

3. Unzip the zipper of the protective cover and roll down it over the balloon cloth (Figure 27).

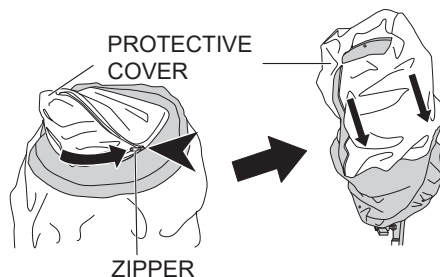

Figure 27. Unzipping Protective Cover

4. Please ensure to close both the zipper and the loop fastener securely. (Figure 28).

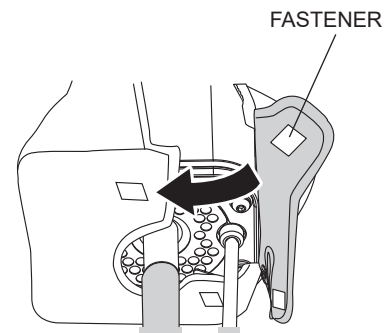

Figure 28. Loop Fastener

LIGHT TOWER STORAGE

1. Wipe dirt or foreign matter that may have accumulated on the light tower during operation. Use a mild detergent to clean the unit. **DO NOT** spray with water.
2. Avoid storing the light tower in areas that can be exposed to rain, harsh elements, and high humidity.
3. Place the light tower in a clean dry location away from dirt and debris.

FORKLIFTING

WARNING

Lift equipment operators should be properly trained in material handling before attempting to lift or move the light tower.

CAUTION

- Before lifting, make sure all panels are closed, and that the lamps are positioned horizontal and down for travel. Ensure that the mast sections are down, and are in the full stow position.
- Before lifting, ensure all jack stands are in a position that will not impede the safe lifting and lowering of the light tower.
- **NEVER** allow anyone underneath or near the light tower during lifting operations.
- **DO NOT** make sudden stops or short turns when conveying light tower by forklift to prevent light tower from falling off the forklift

1. Completely lower the mast.
2. Insert the forks fully into the fork pockets (Figure 29).

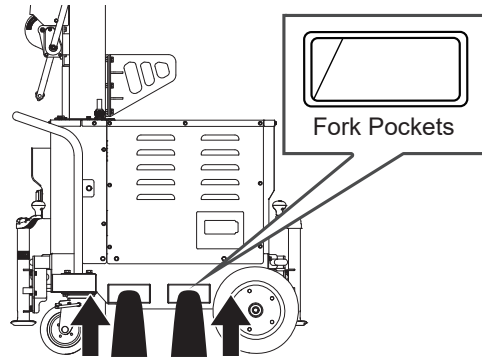

Figure 29. Inserting Forklift Forks

BATTERY CHARGING

There are 2 inlets for charging. When using both inlets, connect them to 2 separate 120VAC 15 A outlets. Charging time differs when one or two inlets are used.

Single Charger	11 hours
Two Chargers	5.5 hours

1. To charge the battery, connect each charging cable to a separate power outlet 120 VAC (Figure 30).

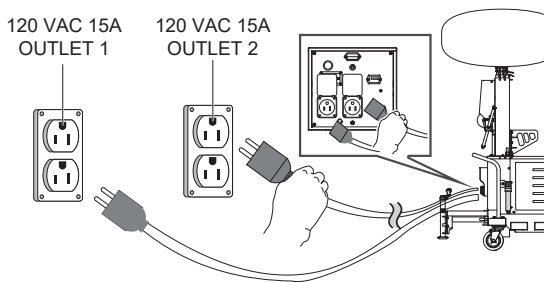
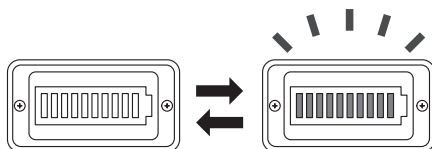

Figure 30. Power Outlets

NOTICE

Make sure that the NEMA 5-15 plug is not contaminated with dust, mud, oil, etc.

2. When reconnecting the charging cable to power outlet, wait at least 10 seconds before doing so.
3. When connected to a power outlet, charging starts automatically and the battery gauge indicator blinks (Figure 31).



BATTERY GAUGE FLASHES
WHEN CHARGING

Figure 31. Battery Charge (Start)

4. When charging is complete, the battery gauge indicator stops blinking and stays lit (Figure 32).

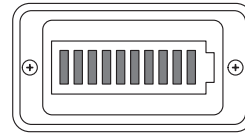

BATTERY GAUGE LIGHTS UP
WHEN CHARGING IS COMPLETE

Figure 32. Battery Charge (Complete)

NOTICE

The charging plug must be properly connected to a 120 VAC 15 A commercial power source. Connection with other power sources may result in charger malfunction or damage.

NOTICE

Leaving the battery with a low level of power may damage or degrade the battery.

CHARGING ENVIRONMENT

1. 120 VAC 15 A is used for charging for each inlet. If other devices are connected, disconnect them before charging. Otherwise, there is a possibility that the circuit breaker may trip.
2. Charge the battery in an environment with an ambient temperature of -20°C (-4°F) to 40°C (104°F).
 - High battery temperatures may increase charging time and degrade the battery.
 - In environments below 0°C , it takes one hour for the battery to warm up, and then the charging process begins.

WARNING

Avoid charging under the scorching sun. There is a risk that the charger may overheat.

Charge in a well-ventilated area away from direct sunlight.

MAINTENANCE

CHARGING CABLES

⚠ WARNING

Using cables with an incorrect wire diameter could cause malfunctions or even lead to ignition.

⚠ WARNING

It is important to take action promptly when dealing with faulty wires or burnt coverings as they can cause electrical leakage or malfunctions.

1. To ensure proper usage of the extension cable, please refer to Table 6 and select the appropriate cable.

Table 6. Cable Extension

Length	AWG
100	AWG14 or more
200	AWG12 or more
300	AWG10 or more

⚠ CAUTION

Exercise caution to avoid stepping on or pinching the cable with the light tower.

REPLACING BALLOON CLOTH

1. Unzip the zipper (Figure 33) at the top and bottom of the balloon cloth.

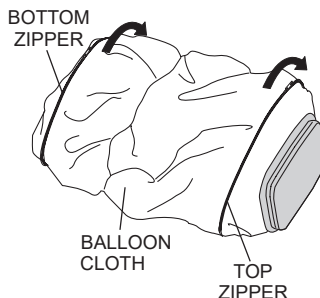

Figure 33. Unzipping the Balloon Cloth

2. Slide the old or worn balloon cloth (Figure 34) over the top of the light assembly.

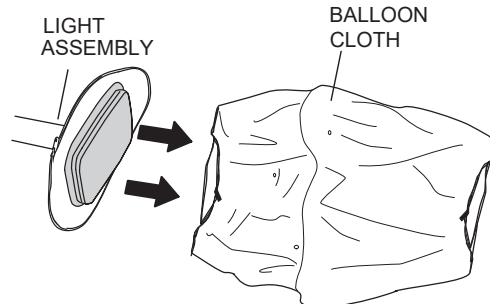

Figure 34. Removing the Balloon Cloth

3. Slide the new balloon (Figure 35) cloth over the top of the light assembly.

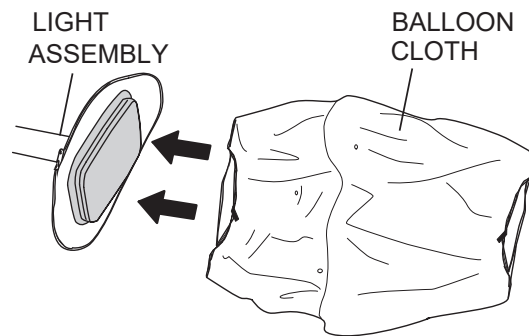

Figure 35. Installing New Balloon Cloth

4. Zip up the zipper (Figure 36) at the top and bottom of the balloon cloth.

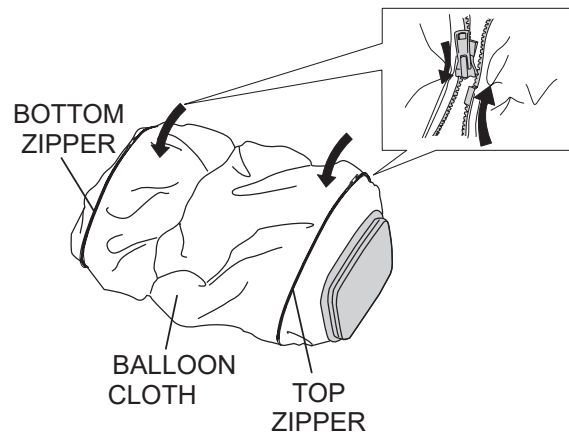

Figure 36. Zipping the Balloon Cloth

REPLACING FILTER

1. Detach balloon and turn light assembly upside down to access filter (Figure 37).

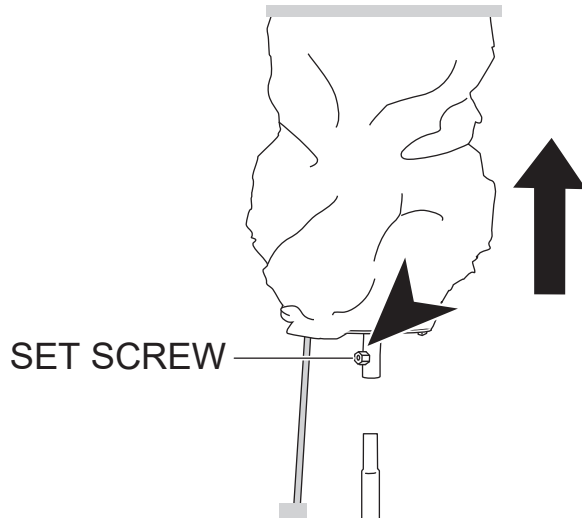

Figure 37. Detaching Balloon

2. Turn all three locking tabs outwards to release the air plate (Figure 38).

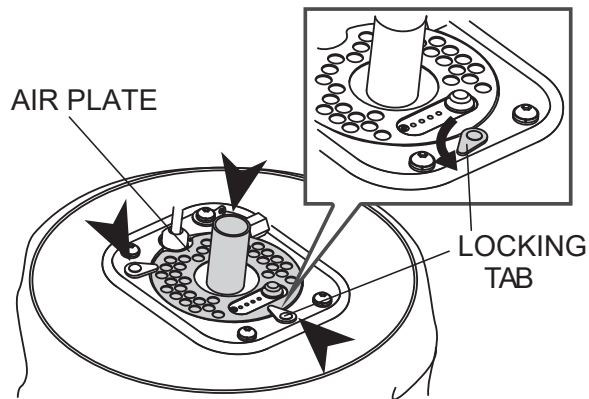

Figure 38. Releasing Air Plate

3. Remove the air plate and the filter (Figure 39).

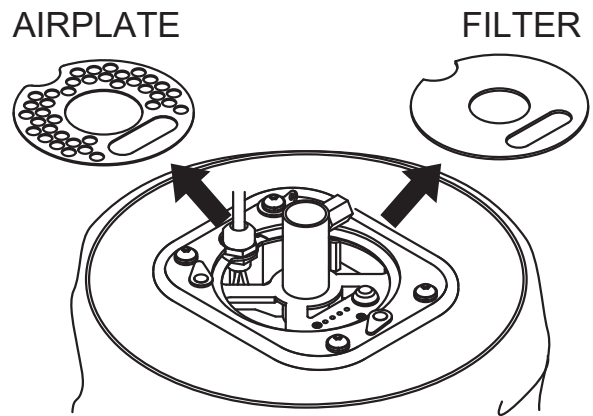

Figure 39. Removing Air Filter

4. Install new filter and reinstall the air plate (Figure 40).

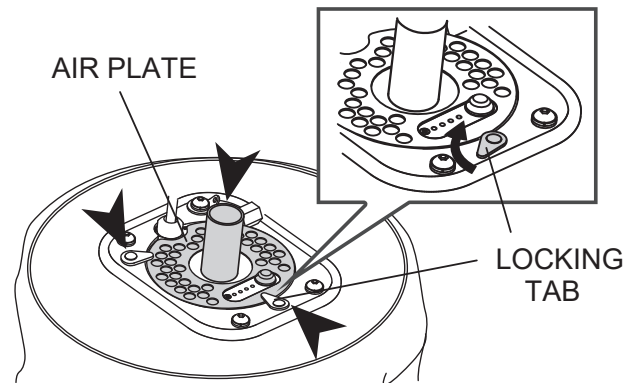

Figure 40. Installing New Filter

5. Turn the three locking tabs inwards to lock the air plate in place.

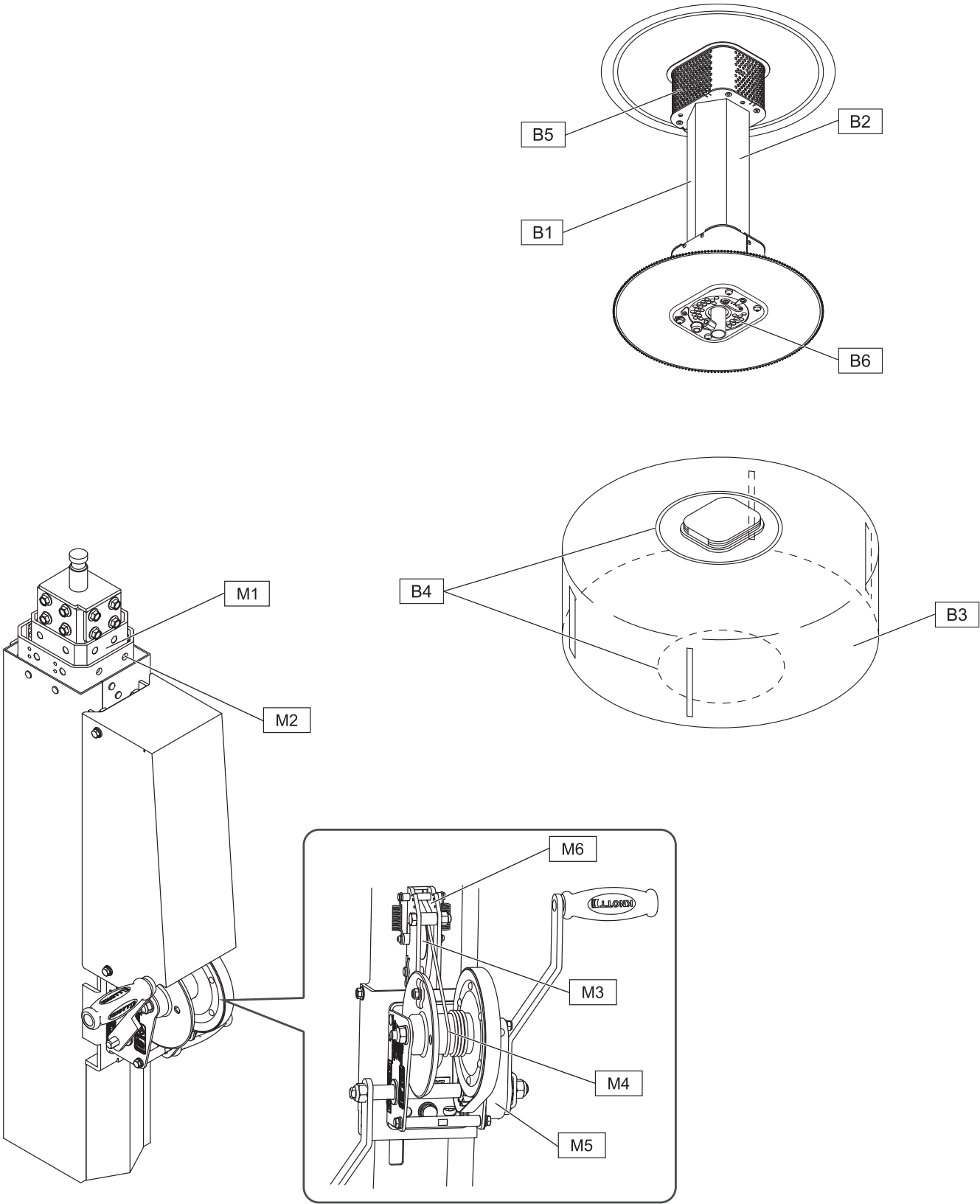

Figure 41. Balloon/Mast Maintenance

MAINTENANCE

Table 7. Balloon/Mast Maintenance

Location	Part	Symptom	Solution	Freq
Balloon	B1	Lamp Guard	Dirty, dusty ,or damaged?	Clean/Replace. ►
	B2	LED Unit	Defective or broken LED?	Replace. ■
	B3	Balloon Cloth	Dirty or ripped?	Replace. ■
	B4	Zipper	Broken?	Replace. ■
	B5	Fan Motor	Does not work properly?	Replace. ●
	B6	Filter	Dirty?	Clean. ●
Mast	M1	Mast Sliding Surface	Does not slide smoothly?	Apply grease. ●
	M2	Slider	Sliders have fallen off or less than 1 mm thickness remain?	Repair/Replace. ●
	M3	Pulley at Winch	Does not move smoothly?	Grease, replace. ●
	M4	Wire Rope	Frayed, rusted, damaged?	Grease, replace. ■
	M5	Winch Brake	Does not operate properly?	Replace. ■
	M6	Safety Stopper	Loose wire rope and stopper jutting out?	Repair/Replace. ■
■ - Daily Check ◆ - Every 20 Hours ● - Every 100 hours ► - Every 500 hours				

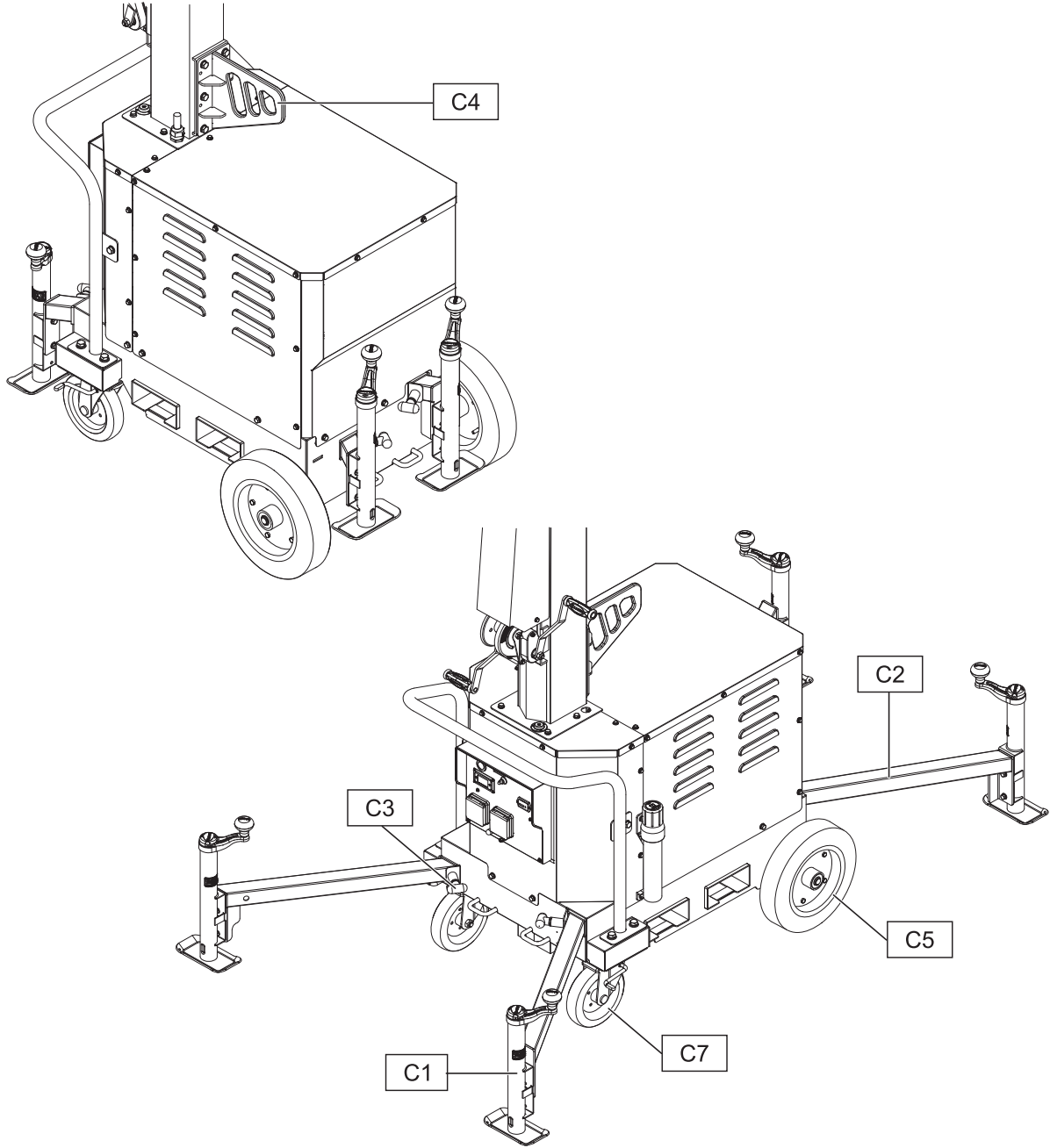

Figure 42. Cart Maintenance

MAINTENANCE

Table 8. Cart Maintenance

Location	Part	Symptom	Solution	Freq.
Cart	C1	Jack	Does not operate smoothly?	Apply grease. ■
	C2	Outrigger	Shape changed?	Replace. ■
	C3	Lock Pin	Lock pin does not work properly?	Replace ■
	C4	Hanger	Damaged?	Replace. ■
	C5	Tire	Damaged?	Replace. ■
	C6	Bolts and Nuts	Loose/ Damaged?	Tighten properly/ Replace. ◆
	C7	Caster	Damaged or Brake does not work?	Replace. ■
■ - Daily Check ◆ - Every 20 Hours ● - Every 100 hours ► - Every 500 hours.				

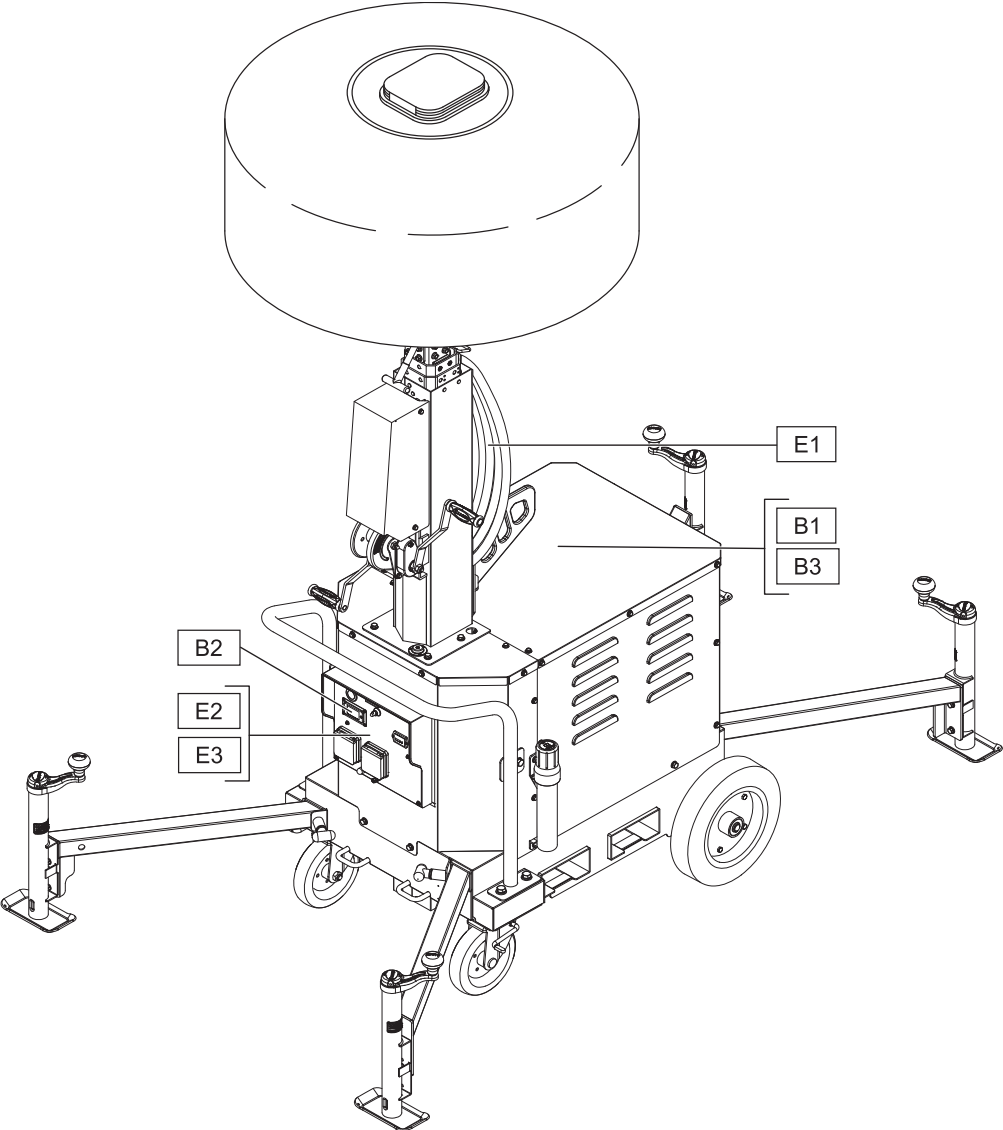

Figure 43. Light Tower/Electric/Battery Maintenance

MAINTENANCE

Table 9. Electrical /Battery Maintenance

Location	Part	Symptom	Solution	Freq.
Electrical	E1	Lamp Cable	Tangled or Damaged?	Untangle or replace ■
	E2	Switches	Does not work properly?	See Troubleshooting ■
	E3	Control Box Connectors	Not connected properly?	Repair needed. •
			Burnt Connectors?	Replace. •
Battery	B1	Battery	Deformed or Damaged?	Replace. ◆
			Dirty connection terminals	Clean. ◆
	B2	Battery Gaugel	Inadequate battery level?	Charge. ■
	B3	Battery Charger	Abnormal charging operation?	Replace. ▲

■ - Daily Check ◆ - Every 20 Hours • - Every 100 hours ► - Every 500 hours..... ▲ - While charging

TROUBLESHOOTING

Table 10. Lamp Troubleshooting (GBBAT8BM)

SYMPTOM	POSSIBLE PROBLEM	SOLUTION
All lighting units do not light up.	Inverter settings are not appropriate?	Make sure the inverter switch is not set to anything other than REM.
	Inverter malfunction?	See Inverter Troubleshooting
	Inverter not securely connected?.	Clean contacts, reconnect, repair wiring.
	Light switch not securely connected?	Clean contacts, reconnect, repair wiring.
	Light switch malfunction?	Replace
	Control board malfunction?	Clean contacts, repair wiring or control board.
	Battery malfunction?	See Battery Troubleshooting.
One or several lighting units do not light up.	Miswiring?	Correct the wiring.
	LED power supply failed?	Replace LED power supply.
Lamps only lights for a short time.	Is the ambient temperature high? (104°F or higher)	Use within the operating temperature range.
	Foreign matter and dust accumulated in cooling fins?	Clean cooling fins.
Dimming does not work.	Control board, dimmer board, and dimmer switch are not securely connected?	Clean contacts, reconnect and repair wiring.
	Dimming switch malfunction?	Replace dimming switch.
	Dimming board or control board malfunction?	Replace.
	Connector between dimmer board and LED power supply is disconnected?	Clean contacts and reconnect.
	LED power supply malfunction?	Replace LED power supply.
Lighting units light up but not so bright.	Dimming function on?	Change dimming switch position.
	The remaining battery charge is less than 5% and the auto dimming function is working?	See Battery Troubleshooting.
	Not bright compared to other lamp?	Replace LED power supply.
	LED panel malfunction?	Manufacture repair.
Some LEDs do not light up.	The remaining battery power is below 5% and in the process of auto-dimming?	Check the battery gauge.
	Inverter output is not stable?	See Battery Troubleshooting.
	LED Power supply is malfunctioning?	Replace.

TROUBLESHOOTING

Table 11. Inverter Troubleshooting (GBBAT8BM)

SYMPTOM	POSSIBLE PROBLEM	SOLUTION
The inverter starts and then stops.	Ambient Temperature is too high?	Use within the acceptable temperature range.
	Cooling is not working well?	Check for accumulation of foreign matter or dust around the louvers on the rear side covers (L and R) and around the inverter air intake and exhaust ports.
		Replace.
	Output short circuit?	Remove any foreign objects
		Replace inverter.
	Poor connection of the internal wiring?	Clean contacts and reconnect.
	Inverter malfunction?	Set the main switch of the inverter to "ON" and see if the inverter starts up when the battery is turned on.
Replace inverter.		
Battery malfunction?	See Battery Troubleshooting	
Inverter does not start.	Inverter malfunction or protection?	See Battery Troubleshooting
	Output short circuit?	Remove any foreign objects
		Replace inverter.
	Inverter not set properly?	Set the main switch to REM.
	Poor connection of internal wiring of the cart?	Check internal wiring connections, clean and reconnect contacts
	Inverter detects abnormal battery voltage?	Restart light tower .Replace battery or inverter.
	Inverter malfunction?	Replace.
Control board malfunction or poor contact?	Clean contacts, repair wiring.	
	Replace control board.	

TROUBLESHOOTING

Table 12. Battery Troubleshooting (GBBAT8BM)

SYMPTOM	POSSIBLE PROBLEM	SOLUTION
Panel light flashes 3 times.	Battery communication error?	Clean contacts, connect tightly, and repair wiring.
	Battery failure?	Replace battery.
	Control board malfunction?	Replace control board.
Panel light flashes every 2 seconds.	Battery over-discharge or dust on wire connectors?	Reduce load and clean connections.
Panel light flashes twice.	Battery internal temperature protection activated?	Operate within specified temperature range.
Panel lights flash at high speed.	Battery overvoltage?	Turn off battery and restart.
Battery gauge comes on for a few seconds and goes off.	Not enough time to press the ON/OFF switch?	Press and hold the ON/OFF switch for about 3 seconds.
The battery gauge does not start.	Battery level is empty?	Charge the battery.
	Disconnection, contact failure, or malfunction of power switch?	Clean contacts, repair wiring and reconnect.
	Battery failure?	Replace battery.

TROUBLESHOOTING

Table 13. Charger Troubleshooting (GBBAT8BM)

SYMPTOM	POSSIBLE PROBLEM	SOLUTION
Does not start charging with use of cord reels and extension cables.	Insufficient input voltage due to voltage drop?	Charge without using a cord reel or shortening the extension distance.
Does not start charging and fan on charger does not work.	Charger malfunction?	Replace the charger.
	Abnormal current / voltage in the output of the charger?	Check the indicator on the charger. Indicator LED flashes red 3 or 4 times at 1 second intervals.
	Poor contacts or broken wires in charger wires?	Clean, reconnect, and repair wiring contacts.
	Reverse connection of charger output?	Rewire battery terminal section.
	Short circuit in charger output or battery failure?	Check the indicator on the charger.
Charging stops midway and fan stops working.	Breaker activates?	Use outlets with different breaker systems.
	Abnormal input voltage?	Do not use cord reels. Try other outlets. Shut down the device on the same power supply system.
Fan is working but charging stops.	Charger thermal protection is activated?	Wait until the temperature is within the operating temperature range and recharge the battery.

TROUBLESHOOTING

Table 14. Mast Troubleshooting

SYMPTOM	POSSIBLE PROBLEM	SOLUTION
Mast cannot be raised.	Lamp cable is caught in mast?	Set cable free.
	Wire rope is cut?	replace the wire rope.
	Cable tangled with the mast?	Disentangle cable.
	Is there foreign matter on the mast?	Remove foreign matter.
	Mast pulley not working?	Replace the mast.
	Winch cannot roll the wire rope smoothly?	Disentangle the wire rope, rewinding it correctly / Replace the wire rope.
	End of wire rope disconnected from winch?	Screw the wire end properly connect wire rope to winch, rewind it correctly.
	Broken winch?	Repair or replace.
Mast cannot be lowered.	Is there foreign matter on the mast?	Remove foreign matter.
	Sudden fall prevention mechanism activated, safety stopper was being operated?	Check for broken wire.
	Is wire caught on safety stopper?	Replace wire.
	Is mast bent?	Repair mast.
	Broken winch?	Repair or replace.

LIGHT WIRING DIAGRAM

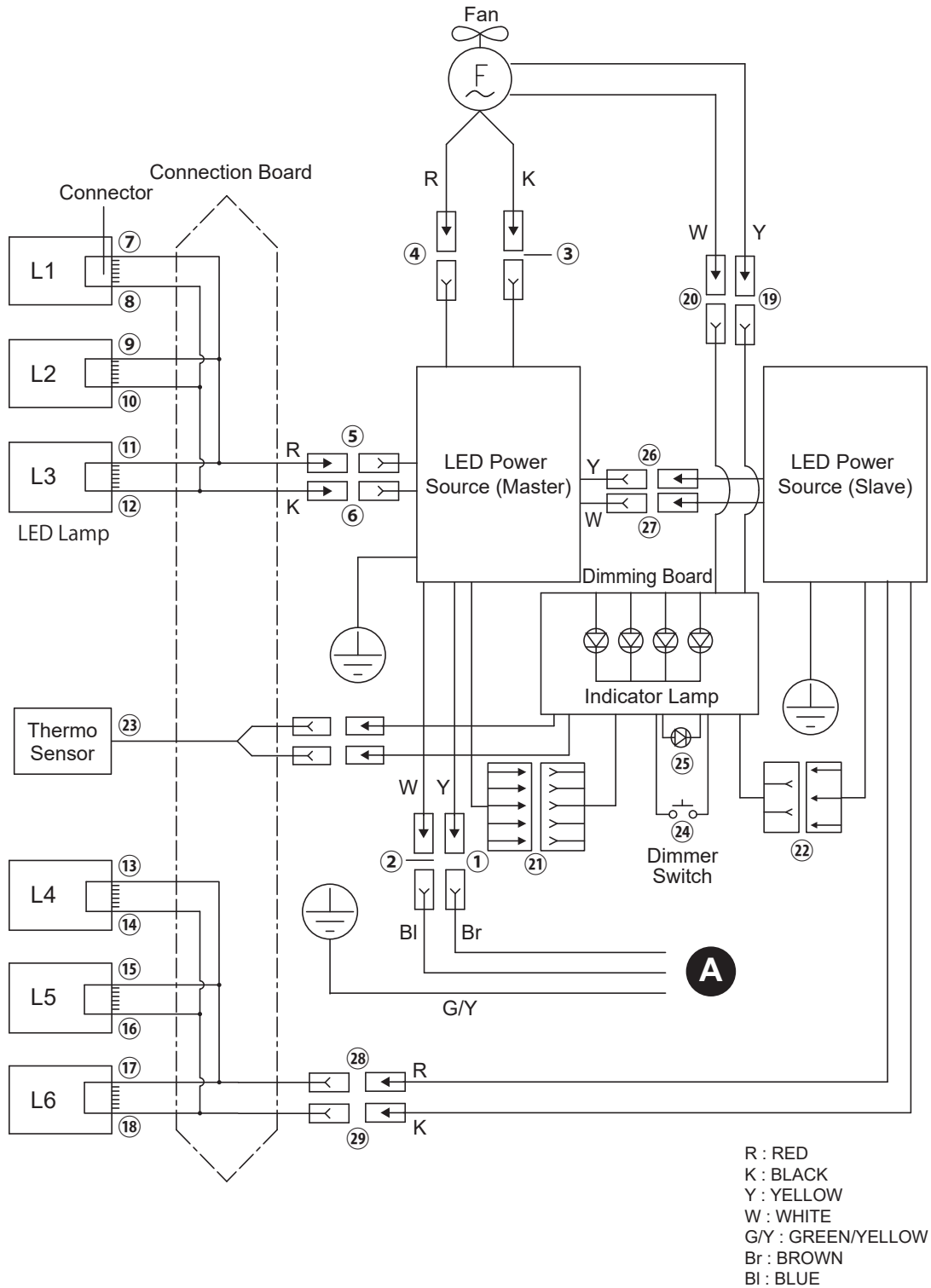

CART WIRING DIAGRAM

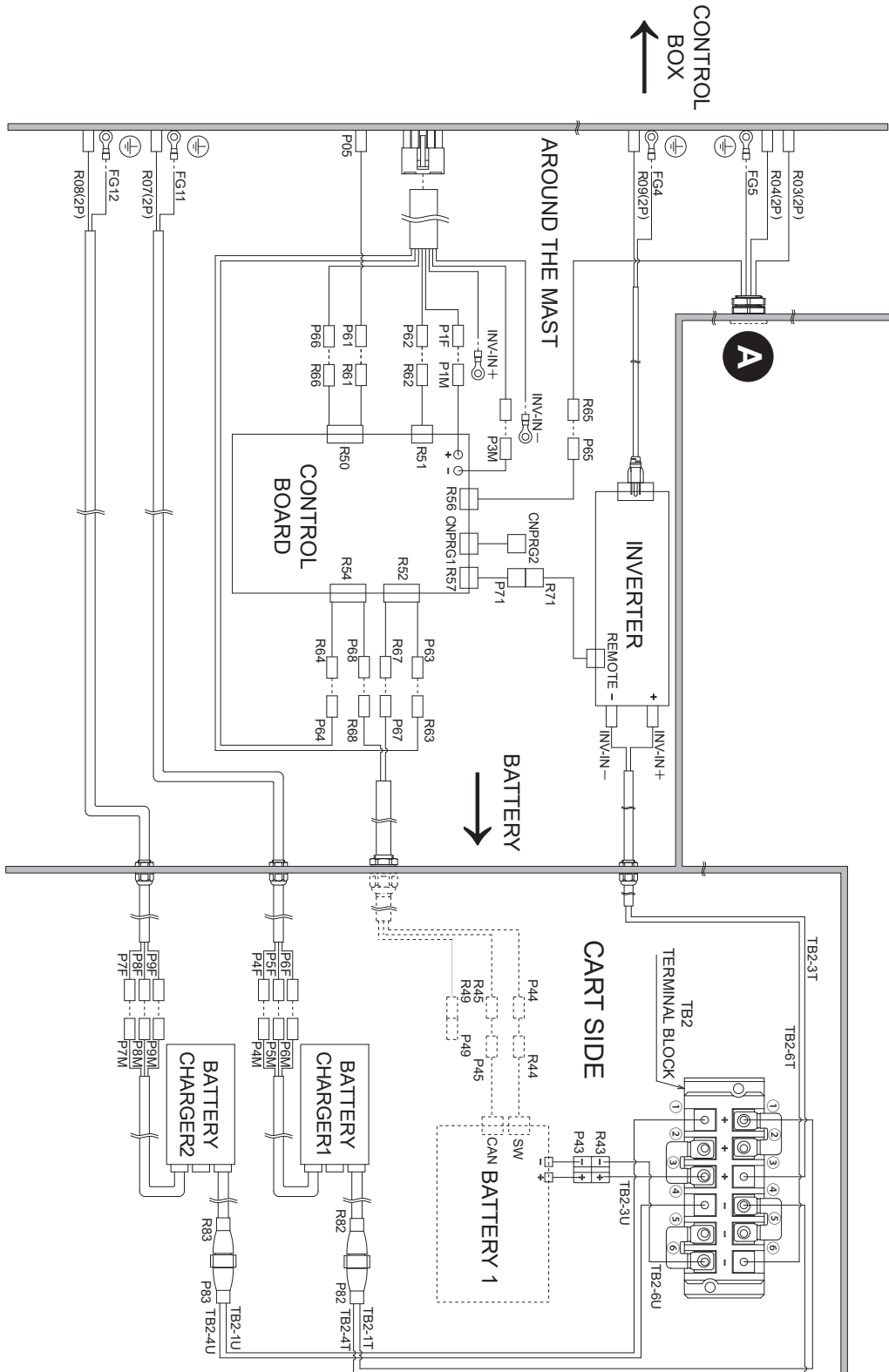

CONTROL BOX WIRING DIAGRAM

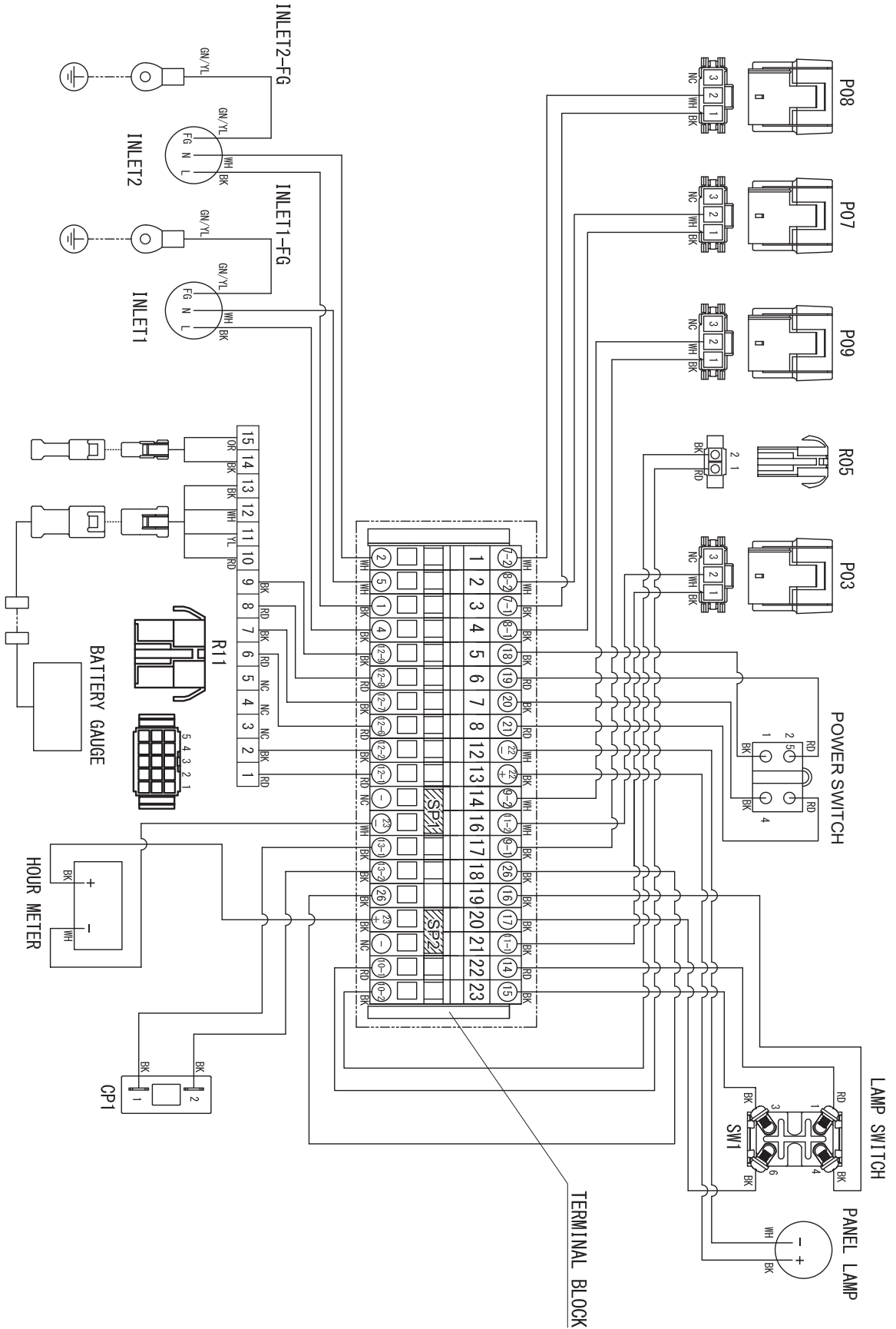

OPERATION MANUAL

HERE'S HOW TO GET HELP

PLEASE HAVE THE MODEL AND SERIAL
NUMBER ON-HAND WHEN CALLING

UNITED STATES

Multiquip Inc.

(310) 537- 3700
6141 Katella Avenue Suite 200
Cypress, CA 90630
E-MAIL: mq@multiquip.com
WEBSITE: www.multiquip.com

CANADA

Multiquip

(450) 625-2244
4110 Industriel Boul.
Laval, Quebec, Canada H7L 6V3
E-MAIL: infocanada@multiquip.com

UNITED KINGDOM

Multiquip (UK) Limited Head Office

0161 339 2223
Unit 2, Northpoint Industrial Estate,
Globe Lane,
Dukinfield, Cheshire SK16 4UJ
E-MAIL: sales@multiquip.co.uk

© COPYRIGHT 2026, MULTIQUIP INC.

Multiquip Inc. and the MQ logo are registered trademarks of Multiquip Inc. and may not be used, reproduced, or altered without written permission. All other trademarks are the property of their respective owners and used with permission.

This manual MUST accompany the equipment at all times. This manual is considered a permanent part of the equipment and should remain with the unit if resold.

DISCLAIMER: Product features, descriptions, and specifications are based on published information at the time of publication and are subject to change at any time without notice. Multiquip Inc. and its affiliates reserve the right to change specifications, features, design, and descriptions of products at any time without notice.

