

OPERATION AND PARTS MANUAL



MODEL HBC19A MODEL HBC25A REBAR CUTTER (PORTABLE ELECTRIC)

Revision #4 (03/30/09)

To find the latest revision of this
publication, visit our website at:
www.multiquip.com



THIS MANUAL MUST ACCOMPANY THE EQUIPMENT AT ALL TIMES.

TABLE OF CONTENTS

HBC19A/HBC25A REBAR CUTTER

Table of Contents	2
Parts Ordering Procedures	3
Safety	4
Rules and Regulations	5-6
Specifications	7
General Information	8
Components	9
Operation	10-11
Maintenance	12-13
Explanation of Codes in Remarks Column	14
Suggested Spare Parts	15

COMPONENT DRAWINGS

Nameplate and Decals	16-17
HBC19A Rebar Cutter Assembly	18-21
HBC25A Rebar Cutter Assembly	22-25
Tools	26-27
Wiring Diagram	28
Terms and Conditions Of Sale — Parts	29

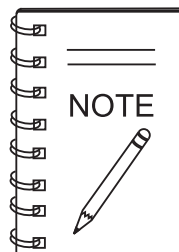

Specification and part number are subject to change without notice.

PARTS ORDERING PROCEDURES

www.multiquip.com

Ordering parts has never been easier! Choose from three easy options:

Effective:
January 1st, 2006



Order via Internet (Dealers Only):

Order parts on-line using Multiquip's SmartEquip website!

- View Parts Diagrams
- Order Parts
- Print Specification Information



If you have an MQ Account, to obtain a Username and Password, E-mail us at: parts@multiquip.com.

To obtain an MQ Account, contact your District Sales Manager for more information.

Goto www.multiquip.com and click on **Order Parts** to log in and save!

Use the **internet** and qualify for a **5% Discount** on *Standard orders* for all orders which include complete part numbers.*

Note: Discounts Are Subject To Change



Order via Fax (Dealers Only):

All customers are welcome to order parts via Fax.

Domestic (US) Customers dial:
1-800-6-PARTS-7 (800-672-7877)

Fax your order in and qualify for a **2% Discount** on *Standard orders* for all orders which include complete part numbers.*

Note: Discounts Are Subject To Change



Order via Phone: Domestic (US) Dealers Call:
1-800-427-1244

Non-Dealer Customers:

Contact your local Multiquip Dealer for parts or call 800-427-1244 for help in locating a dealer near you.



International Customers should contact their local Multiquip Representatives for Parts Ordering information.

When ordering parts, please supply:

- | | |
|---|--|
| <input type="checkbox"/> Dealer Account Number | <input type="checkbox"/> Specify Preferred Method of Shipment: |
| <input type="checkbox"/> Dealer Name and Address | <input checked="" type="checkbox"/> UPS/Fed Ex <input checked="" type="checkbox"/> DHL |
| <input type="checkbox"/> Shipping Address (if different than billing address) | <input type="checkbox"/> Priority One <input checked="" type="checkbox"/> Truck |
| <input type="checkbox"/> Return Fax Number | <input type="checkbox"/> Ground |
| <input type="checkbox"/> Applicable Model Number | <input type="checkbox"/> Next Day |
| <input type="checkbox"/> Quantity, Part Number and Description of Each Part | <input type="checkbox"/> Second/Third Day |

NOTICE

All orders are treated as *Standard Orders* and will ship the same day if received prior to 3PM PST.

WE ACCEPT ALL MAJOR CREDIT CARDS!



FOR YOUR SAFETY AND SAFETY OF OTHERS!

Safety precautions should be followed at all times when operating this equipment. Failure to read and understand the Safety Messages and Operating Instructions could result in injury to yourself and others.

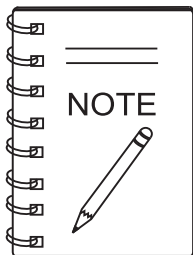

This manual has been developed to provide complete instructions for the safe and efficient operation of this equipment.

Before using this equipment ensure that the operating individual has read and understood all instructions in this manual.

SAFETY MESSAGE ALERT SYMBOLS

The three Safety Messages shown below will inform you about potential hazards that could injure you or others. The Safety Messages specifically address the level of exposure to the operator, and are preceded by one of three words: **DANGER**, **WARNING**, or **CAUTION**.

DANGER

You **WILL** be **KILLED** or **SERIOUSLY INJURED** if you **DO NOT** follow these directions.

WARNING

You **CAN** be **KILLED** or **SERIOUSLY INJURED** if you **DO NOT** follow these directions.

CAUTION

You **CAN** be **INJURED** if you **DO NOT** follow these directions.

HAZARD SYMBOLS

Potential hazards associated with the operation of this equipment will be referenced with Hazard Symbols which appear throughout this manual, and will be referenced in conjunction with Safety Message Alert Symbols.

WARNING — Respiratory Hazards



ALWAYS wear approved respiratory protection when required.

CAUTION — Rotating Parts Hazards



NEVER operate equipment with covers or guards removed. Keep fingers, hands, hair and clothing away from all moving parts to prevent injury.

CAUTION — Accidental Starting Hazards



ALWAYS place the equipment ON/OFF switch in the OFF position when the equipment is not in use.

CAUTION — Eye and Hearing Hazards



ALWAYS wear approved eye and hearing protection.

CAUTION — Equipment Damage Hazards

Other important messages are provided throughout this manual to help prevent damage to your equipment, other property, or the surrounding environment.

RULES AND REGULATIONS

WARNING — Read This Manual

Failure to follow instructions in this manual may lead to serious injury or even **DEATH!** This equipment is to be operated by trained and qualified personnel only! This equipment is for industrial use only.

GENERAL SAFETY

- **DO NOT** operate or service this equipment before reading this entire manual. 
- This equipment should not be operated by persons under 18 years of age.
- **NEVER** operate this equipment without proper protective clothing, shatterproof glasses, steel-toed boots and other protective devices required by the job.



- **NEVER** operate this equipment when not feeling well due to fatigue, illness or when under medication. 
- **NEVER** operate this equipment under the influence of drugs or alcohol.





- **NEVER** use accessories or attachments that are not recommended by Multiquip for this equipment. Damage to the equipment and/or injury to user may result.
- Manufacturer does not assume responsibility for any accident due to equipment modifications. Unauthorized equipment modification will void all warranties.
- Whenever necessary, replace nameplate, operation and safety decals when they become difficult to read.
- **ALWAYS** check the equipment for loosened threads or bolts before starting.
- **MAINTAIN** equipment in a safe operating condition at all times.
- **KEEP** bystanders, children, and visitors away while operating the equipment. Distractions can cause loss of control.

- **DO NOT** wear loose clothing or jewelry. Contain long hair. Keep hair, clothing, and gloves away from moving parts. Rotating parts can cause injury if contacted.
- **ALWAYS** keep work area clean and free of foreign matter and debris. Also keep work area well lit.
- **NEVER** operate the equipment in an explosive atmosphere or near combustible materials. An explosion or fire could result causing severe **bodily harm or even death**. 
- **DO NOT** overreach. Keep proper footing and balance at all times.
- **NEVER** leave the equipment unattended. When not in use, before servicing, and when changing accessories, always unplug the equipment from the power source.
- **USE** this equipment for its intended purpose only.
- **KEEP** equipment clean for better and safer performance. Keep handles dry, clean, and free from oil and grease.
- **INSPECT** the equipment after each use. Replace any damaged or worn parts immediately. Do not use equipment if defective.
- If a malfunction occurs, immediately unplug the equipment from the power source and correct the problem. If problem cannot be corrected, contact the nearest MQ service center.

- **ALWAYS** store the equipment in a clean, dry location out of the reach of children.

EMERGENCIES

- **ALWAYS** know the location of the nearest **fire extinguisher**. 
- **ALWAYS** know the location of the nearest **first aid kit**. 
- In emergencies, **always** know the location of the nearest phone or **keep a phone on the job site**. Also know the phone numbers of the nearest **ambulance, doctor** and **fire department**. This information will be invaluable in case of emergency.

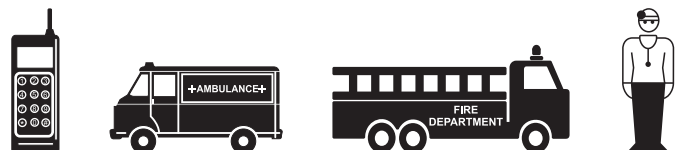

RULES AND REGULATIONS

ELECTRICAL SAFETY

- **ALWAYS** test the **POWER** switch on the equipment before operating. The purpose of this switch is to shut down the power.
- **NEVER** use an extension cord that is frayed or damaged where the insulation has been cut.
- **NEVER** carry the equipment by its power cord or disconnect it by yanking the cord from the power outlet.
- **ALWAYS** make certain that the proper extension cord has been selected for the job. See Extension Cord Gauge Selection Table.
- **NEVER** allow power cord to *lay in water*.
- **NEVER stand in water** while operating the equipment.
- When connecting the unit to a power receptacle, make sure the receptacle circuit is connected to either a GFCI receptacle or a receptacle protected by a 20 amp circuit breaker.
- When plugging the unit into a power receptacle, check the nameplate for the correct operating voltage. Operating the rebar bender at the wrong voltage will damage the electrical components. **ALWAYS** read the nameplate before applying power.
- This unit is equipped with a 3-prong male power plug. **DO NOT** use a 2-prong adapter when plugging into a wall outlet. This will defeat the purpose of the ground circuit. If the plug does not fit into the receptacle, contact a qualified electrician to install a 3-conductor wall receptacle (outlet).
- Avoid body contact with grounded surfaces such as pipes, radiators, ranges and refrigerators. There is an increased risk of electrical shock if your body is grounded.
- **DO NOT** expose the hydraulic power unit to rain or wet conditions. Water entering the power unit will increase the risk of electrical shock.
- When operating the unit outdoors, be sure to use the appropriate outdoor extension cord. This type of extension cord reduces the risk of electrical shock.
- **ALWAYS** remove the AC power cord from the power source before performing any service or maintenance on the unit. This preventative safety measure reduces the possibility of accidental starting.
- When operating near an arc welder, it is important the both the unit and the welding equipment be connected to the same earth ground. If they are not, server damage to the unit, particularly to the power cord could occur. Personal injury may also occur.

Extension Cord Gauge Selection										
Ampere Rating Range	Volts	Length of Cord in Feet								
	115V	25 Ft.	50 Ft.	100 Ft.	150 Ft.	200 Ft.	250 Ft.	300 Ft.	400 Ft.	500 Ft.
	230V	50 Ft.	100 Ft.	200 Ft.	300 Ft.	400 Ft.	500 Ft.	600 Ft.	800 Ft.	1000 Ft.
0 - 2		18	18	18	16	16	14	14	12	12
2 - 3		18	18	16	14	14	12	12	10	10
3 - 4		18	18	16	14	12	12	10	10	8
4 - 5		18	18	14	12	12	10	10	8	8
5 - 6		18	16	14	12	10	10	8	8	6
6 - 8		18	16	12	10	10	8	6	6	6
8 - 10		18	14	12	10	8	8	6	6	4
10 - 12		16	14	10	8	8	6	6	4	4
12 - 14		16	12	10	8	6	6	6	4	2
14 - 16		16	12	10	8	6	6	4	4	2
16 - 18		14	12	8	8	6	4	4	2	2
18 - 20		14	12	8	6	6	4	4	2	2

SPECIFICATIONS

Table 1. Specifications

Model	HBC19A	HBC25A
Maximum Cutting Capacity		
Intermediate Grade (40) 70,000 psi (45 kg/mm ²)	No. 6, Size 3/4 in (19 mm)	No. 8 Size 1 in (25 mm)
Hard Grade (50) 80,000 psi (55 kg/mm ²)	No. 6, Size 3/4 in (19 mm)	No. 8 Size 1 in (25 mm)
High Tensile Strength Grade (60) 90,000 psi (65 kg/mm ²)	No. 6, Size 3/4 in (19 mm)	No. 8, Size 1 in (25 mm)
Cutting Speed	2.5 sec	3.5 sec
Rated Power	1330 W	1430 W
Amps	11 A	13 A
Power Source	115 V single-phase AC	115 V single-phase AC
Weight	27 lb (12.25 kg)	48.5 lb (22 kg)
Dimensions		
Length	15.6 in (396.2 mm)	18.9 in (480 mm)
Width	4.4 in (111.8 mm)	5.4 in (137.2 mm)
Height	8.7 in (221 mm)	10.6 in (269.2 mm)
Standard Equipment		
Allen Wrench	4 pieces (M3, 4, 5, 6)	4 pieces (M4, 5, 6, 8)
Hydraulic Oil	5 oz (150 ml)	5 oz (150 ml)
Carrying Box	Wooden Box	Wooden Box
Open-End Wrench	0.67 x 0.75 in (17 x 19 mm)	0.55 x 0.67, 0.94 in (14 x 17, 24 mm)

GENERAL INFORMATION

GENERAL INFORMATION

The **MQ HBC19A/HBC25A Rebar Cutter** is designed to be used as a portable on-site rebar cutter, capable of cutting in-place rebar safely and efficiently with the squeeze of a trigger. Labor time and injuries are greatly reduced from manually cutting rebar. The cutter can virtually handle any rebar cutting job, from slabs and masonry walls to large buildings and bridges.

The rebar cutter contains a built-in hydraulic pump with innovative magnetic particle filtering. All parts are machined to tight tolerances for maximum performance.

At approximately 27 to 49 pounds, the cutter is easily carried around job sites. Even overhead work takes minimum effort.

The cutting rod returns to the starting position when the operating switch is released after the rod makes its full cutting stroke. The cutting rod will not move if the cutting stroke is not finished. The operating switch must be held long enough for cutting rod to complete stroke.

The HC19A/HBC25A comes with a return valve that allows the cutter rod to return to the starting position when the cutter blade jams and stops during cutting of a rebar.

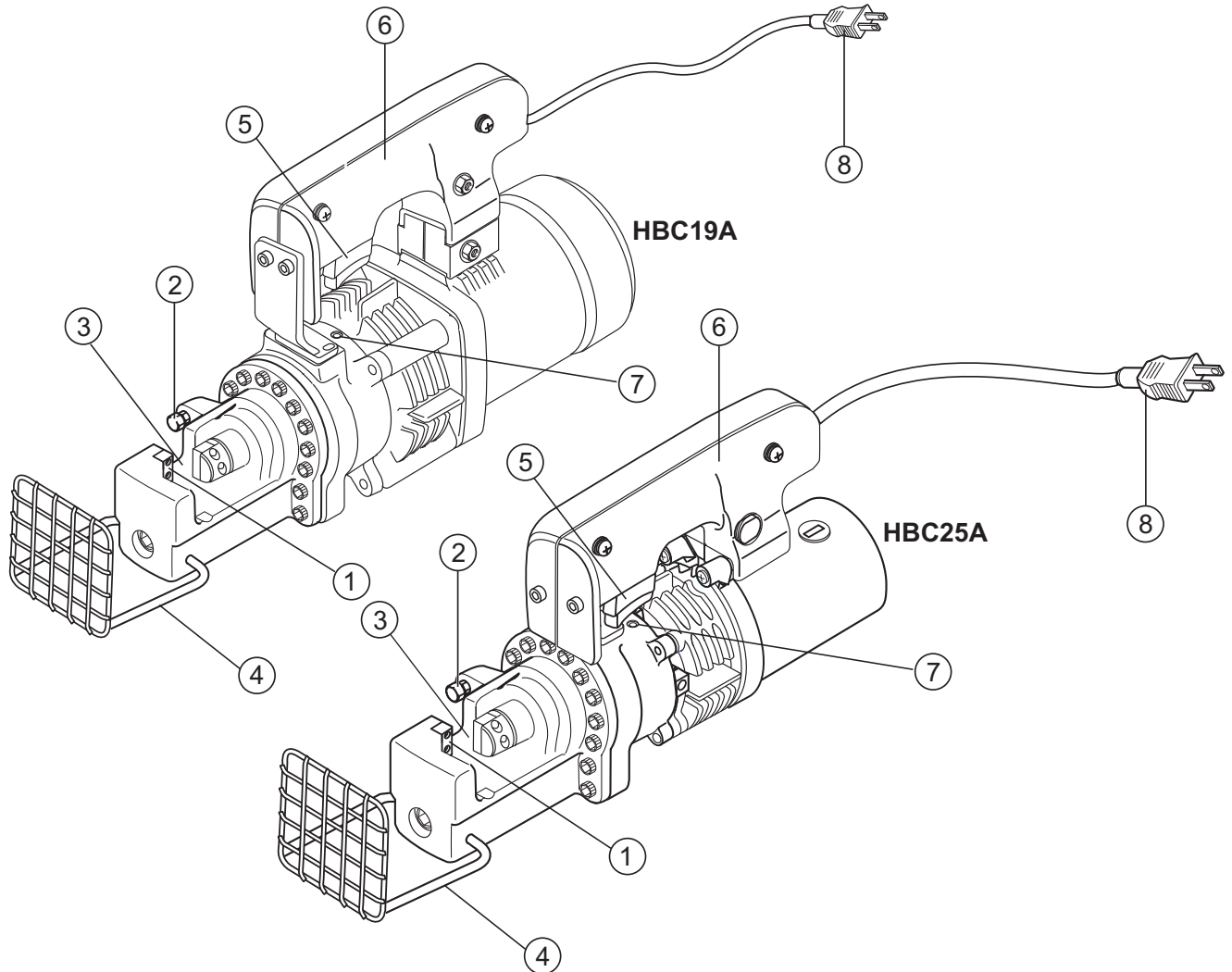

Figure 1. HBC19A/HBC25A Components

Figure 1 shows the components of the HBC19A/HBC25A Rebar Cutter. These components are described below.

1. **Blade** (set of two) - Cuts the rebar that is set on the holder between the blades.
2. **Spacing Bolt and Nut** - Allows rebar of different diameters to be cut by adjusting the space between the blades.
3. **Rebar Holder** - Holds the rebar to be cut.
4. **Protector** - Covers the rebar while cutting to prevent rebar fragments from flying out.
5. **ON/OFF Switch** - Starts the cutting of the rebar when the trigger switch is squeezed. When released, cutting is stopped. Do not release release switch until the rebar is completely cut.
6. **Handle** - Used to lift the rebar cutter.
7. **Return Valve** - Returns the cutter rod to the starting position when the cutter blade jams and stops the cutting of a rebar. This is done by rotating the return valve half a turn in a counterclockwise direction with the hexagonal wrench supplied with the unit.
8. **Power Plug** - connects to a 150V, 60 Hz power source.

CUTTING PROCEDURE

WARNING

Make sure that the bar is resting fully within the blades and protector is in the upright position. If the rebar is not properly set, the cutting piece or fragments of the rebar may scatter as soon as rebar is cut and the cutter can also be damaged.

1. Adjust the spacing bolt according to the diameter of the rebar being cut. Bolt must allow rebar to be flush, at 90° to the blades.
2. Connect the electric plug from the cutter to a proper power source (115 volts, 60 Hz).
3. Place the rebar in the rebar holder. Rebar must rest fully within the blades. See Figure 2. Position the protector over the surface to be cut.

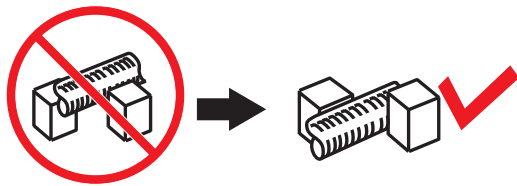
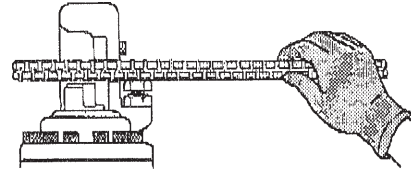

Figure 2. Rebar Placement

4. Tighten the spacing bolt and jam nut to hold the rebar in place.
5. Squeeze the ON/OFF switch to start cutting the rebar. Keep holding the ON/OFF switch until the cutting rod completes cutting cycle. Do not attempt to partially cut through the diameter of the rebar. This will cause damage to the blades and cause the rebar to fly out.
6. At the end of the cutting cycle, release the ON/OFF switch. The cutter rod will retract automatically.
7. If cutter reaches 158° F or higher, stop cutting operation and allow machine to cool before using again.
8. Periodically inspect oil level and electric motor brushes. Refer to Maintenance section for details.

WARNING

Do not cut rebar when it is not properly supported by the spacing bolt or if the spacing bolt is not properly adjusted. When cutting, hold the rebar on the spacing bolt side as shown below. If not, the cut piece may fly off and cause serious injury to the operator or bystanders.



CAUTION

NEVER use worn or damaged blades. Replace immediately before using cutter again.

WARNING

Replace damaged (broken and cracked edge) or deformed cutter as soon as possible. Damaged cutter could cause the rebar to get out of place or cracked during cutting. This may cause a serious accident. Do not cut rebar that is less than 8 inches (200 mm) in length as this may cause rebar to fly off and result to personal injury.

WARNING



Keep hands and face away from the blades and other rotating or sliding parts during operation.

RETURN VALVE OPERATION

The return valve is used when the cutter blade jams and stops during cutting of the rebar.

1. Rotate the return valve half a turn in the counterclockwise direction with the allen wrench (no. 4) supplied with the unit. See Figure 3 for location.

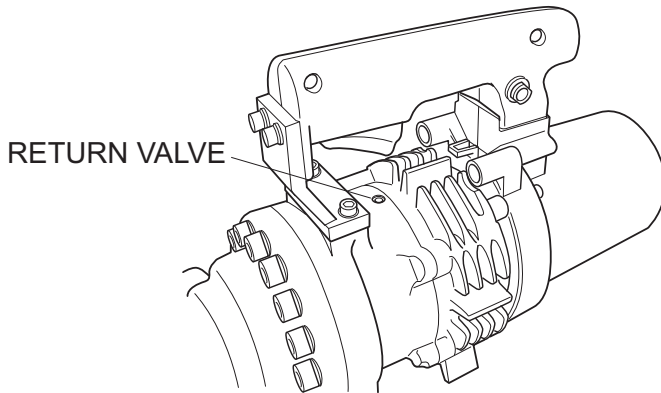

Figure 3. Return Valve

2. The cutter rod will retract and return to its starting position.
3. Once the cutter rod returns to its starting position, tighten the return valve before resuming rebar cutting.

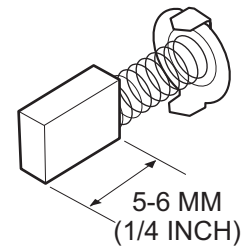

Figure 4. Carbon Brush Size

1. Make sure that the power plug is not connected to the power source.
2. For the HBC19A, remove the 2 bolts holding the cover using a 4mm allen-head wrench then remove the cover to access the two carbon brush caps (one on each side). See Figure 5.

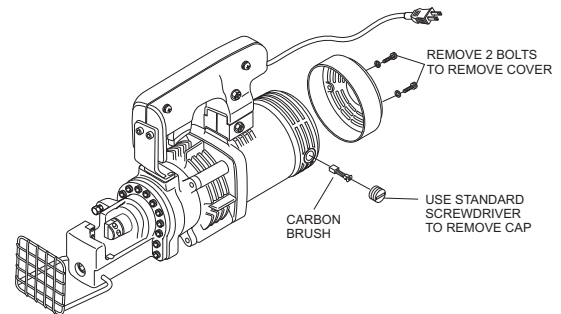

Figure 5. Replacing Carbon Brushes (HBC19A)

3. Remove the carbon brush cap of the motor outer frame using a standard screwdriver. See Figures 5 and 6.

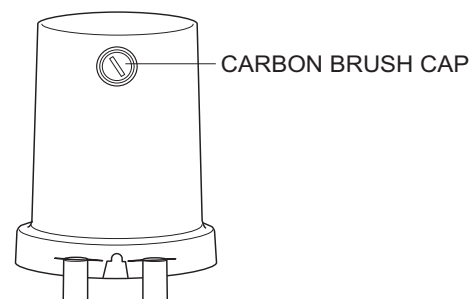



Figure 6. Replacing Carbon Brushes (HBC25A)

4. Replace the carbon brushes with new ones (two for the HBC19A and one for the HBC25A).
5. Put back the cap after brush is installed.
6. For the HBC19A, replace cover and tighten 2 bolts.

⚠ DANGER

During operation of this rebar cutter, there exists the possibility of **electrocution, electrical shock or burn**, which can cause **severe bodily harm** or even **DEATH!**



To avoid these hazards:

- NEVER** use damaged or worn cables when plugging the rebar cutter into an AC power receptacle.
- NEVER** grab or touch a live power cord with wet hands.
- NEVER** stand in water and touch a live power cord.

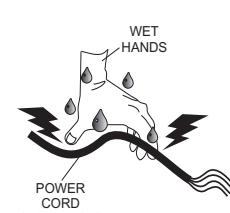

⚠ WARNING

Unplug unit from power source before replacing carbon brushes.

REPLACING CARBON BRUSHES

When the carbon becomes less than 5 or 6 mm (1/4 inch) the motor force deteriorates because of low rectification (Figure 4). The carbon brushes need to be replaced at this time. It is also recommended that the brushes be replaced after 200 hours of use.

REPLACING OIL

The rebar cutter uses hydraulic action to operate. If there is insufficient, dirty, or improper oil in the cutter, it will not operate at full capacity. If unit is not operating properly, check oil level and condition. If necessary, replace oil as follows:

1. Loosen oil fill bolt with the supplied open-end wrench. Remove oil fill bolt and lay cutter to allow oil to drain out. See Figure 7.

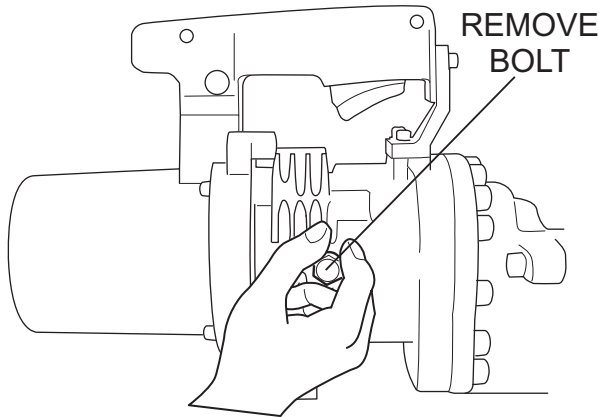

Figure 7. Removing Oil Fill Bolt

2. Turn cutter so that the oil fill port is on the top side. Fill with oil until it overflows. See Figure 8. See Table 2 for oil type and quantity.

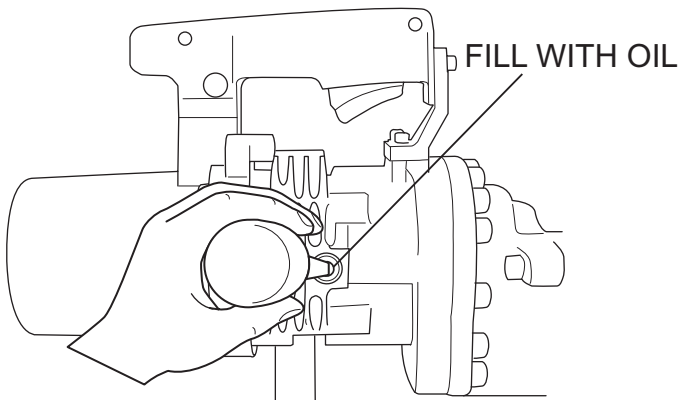

Figure 8. Oil Fill

Table 2. Oil Type

Model	HBC19A	HBC25A
Quantity	5 oz (150 ml)	5 oz (150 ml)
Oil Type	Shell Tellus Oil #46 Exxon Teresstic #46	Shell Tellus Oil #32 Exxon Teresstic #32

Above grades are blended to viscosity values that conform to the ISO (International Standards Organization) viscosity classification system.

3. Shake the cutter up and down to release any air bubble that may be present.
4. Overfill with oil again.
5. Replace bolt in fill port and wipe off any excess oil.
6. Connect the cutter power cord to the power source. Place a 3/16-inch diameter steel rod in bar holder. Squeeze ON/OFF switch to activate the cutter and allow the blade to touch the rod then turn off then release the ON/OFF switch.
7. Turn cutter so that the oil fill port is on the top side once again. Repeat oil fill procedure.
8. Squeeze ON/OFF switch again to continue and finish cutting operation started earlier.
9. When cutting is complete, filling procedure is done.

⚠ WARNING

Unplug unit from power source before troubleshooting.

Table 3. Troubleshooting

Symptom	Possible Problem	Solution
Cutter rod is stuck.	Oil is insufficient?	Add oil. See instructions in Maintenance section.
	Cutter rod did not retract completely due to reinforcement steel chips, iron powder and dirt present in the sliding portion of the cutter rod and the bar holder?	Push back cutter rod. Clean cutter rod.
	Cutter rod did not retract completely due to the distortion or swelling of cutter rod blade?	Tighten blade bolts. Replace cutter rod blade.
	Cutter rod did not retract completely due to a weak cutter rod return spring?	Replace return spring.
Cutter rod comes out but cutting power is too weak to cut rebar.	Oil is insufficient?	Add oil. See instructions in Maintenance section.
	Contact between cylinder and release valve (tip surface of projection in cylinder) is improper?	Make sure that there are no scratches at tip of surface of cylinder. Clean any stuck iron powder or dirt.
	Is release valve broken?	Replace release valve.
	Improper clearance between cylinder and piston?	Replace cylinder and piston.
	Improper contact between cylinder and valve?	Replace cylinder and valve.
	Broken cylinder rubber packing?	Replace rubber packing.
Oil is leaking.	Scratched or broken oil leveler sack?	Replace defective part.
	Scratched bar holder slider and cylinder?	Replace defective part.
	Broken cylinder joint liner and pump case?	Replace defective part.
	Insufficient tightening of oil fill bolt?	Tighten oil fill bolt.
Motor does not rotate or poor motor rotation.	Incorrect voltage?	Make sure unit is connect to proper power source.
	Abrasion of carbon brushes?	Replace carbon brushes.
	Broken or deformed bearings at both ends of armature.	Replace bearings.

NOTE: The internal components of the hydraulic pump and piston area have very close clearances are sensitive to damage from dust, dirt, contamination of the hydraulic fluid or improper handling. The disassembly of the pump must be done by properly trained personnel with the correct equipment. The improper servicing of electrical components can lead to conditions that could cause serious injury. The pump and piston components and all electrical components should be serviced by a factory authorized repair center. Any attempt by unauthorized personnel to service internal components of the rebar cutter will void the warranty.

EXPLANATION OF CODE IN REMARKS COLUMN

The following section explains the different symbols and remarks used in the Parts section of this manual. Use the help numbers found on the back page of the manual if there are any questions.

NOTICE

The contents and part numbers listed in the parts section are subject to change **without notice**. Multiquip does not guarantee the availability of the parts listed.

SAMPLE PARTS LIST

NO.	PART NO.	PART NAME	QTY.	REMARKS
1	12345	BOLT.....	1	INCLUDES ITEMS W/%
2%		WASHER, 1/4 IN.....		NOT SOLD SEPARATELY
2%	12347	WASHER, 3/8 IN....	1	MQ-45T ONLY
3	12348	HOSE	A/R	MAKE LOCALLY
4	12349	BEARING	1	S/N 2345B AND ABOVE

NO. Column

Unique Symbols — All items with same unique symbol

(@, #, +, %, or >) in the number column belong to the same assembly or kit, which is indicated by a note in the “Remarks” column.

Duplicate Item Numbers — Duplicate numbers indicate multiple part numbers, which are in effect for the same general item, such as different size saw blade guards in use or a part that has been updated on newer versions of the same machine.

NOTICE

When ordering a part that has more than one item number listed, check the remarks column for help in determining the proper part to order.

PART NO. Column

Numbers Used — Part numbers can be indicated by a number, a blank entry, or TBD.

TBD (To Be Determined) is generally used to show a part that has not been assigned a formal part number at the time of publication.

A blank entry generally indicates that the item is not sold separately or is not sold by Multiquip. Other entries will be clarified in the “Remarks” Column.

QTY. Column

Numbers Used — Item quantity can be indicated by a number, a blank entry, or A/R.

A/R (As Required) is generally used for hoses or other parts that are sold in bulk and cut to length.

A blank entry generally indicates that the item is not sold separately. Other entries will be clarified in the “Remarks” Column.

REMARKS Column

Some of the most common notes found in the “Remarks” Column are listed below. Other additional notes needed to describe the item can also be shown.

Assembly/Kit — All items on the parts list with the same unique symbol will be included when this item is purchased.

Indicated by:

“INCLUDES ITEMS W/(unique symbol)”

Serial Number Break — Used to list an effective serial number range where a particular part is used.

Indicated by:

“S/N XXXXX AND BELOW”

“S/N XXXX AND ABOVE”

“S/N XXXX TO S/N XXX”

Specific Model Number Use — Indicates that the part is used only with the specific model number or model number variant listed. It can also be used to show a part is NOT used on a specific model or model number variant.

Indicated by:

“XXXXX ONLY”

“NOT USED ON XXXX”

“Make/Obtain Locally” — Indicates that the part can be purchased at any hardware shop or made out of available items. Examples include battery cables, shims, and certain washers and nuts.

“Not Sold Separately” — Indicates that an item cannot be purchased as a separate item and is either part of an assembly/kit that can be purchased, or is not available for sale through Multiquip.

SUGGESTED SPARE PARTS

HBC19A/25A REBAR CUTTER

1 to 3 Units

Qty.	P/N	Description
2	6415710	BRUSH CAP (FOR HBC19A)
2	6402520	BRUSH CAP (FOR HBC25A)
2	6415730	CARBON BRUSH (FOR HBC19A)
2	6402510	CARBON BRUSH (FOR HBC25A)
2	H9T4495400	BLADE, SET OF 2 (FOR HBC19A)
2	H9T4495500	BLADE, SET OF 2 (FOR HBC25A)

HBC19A/HBC25A — NAMEPLATE AND DECALS

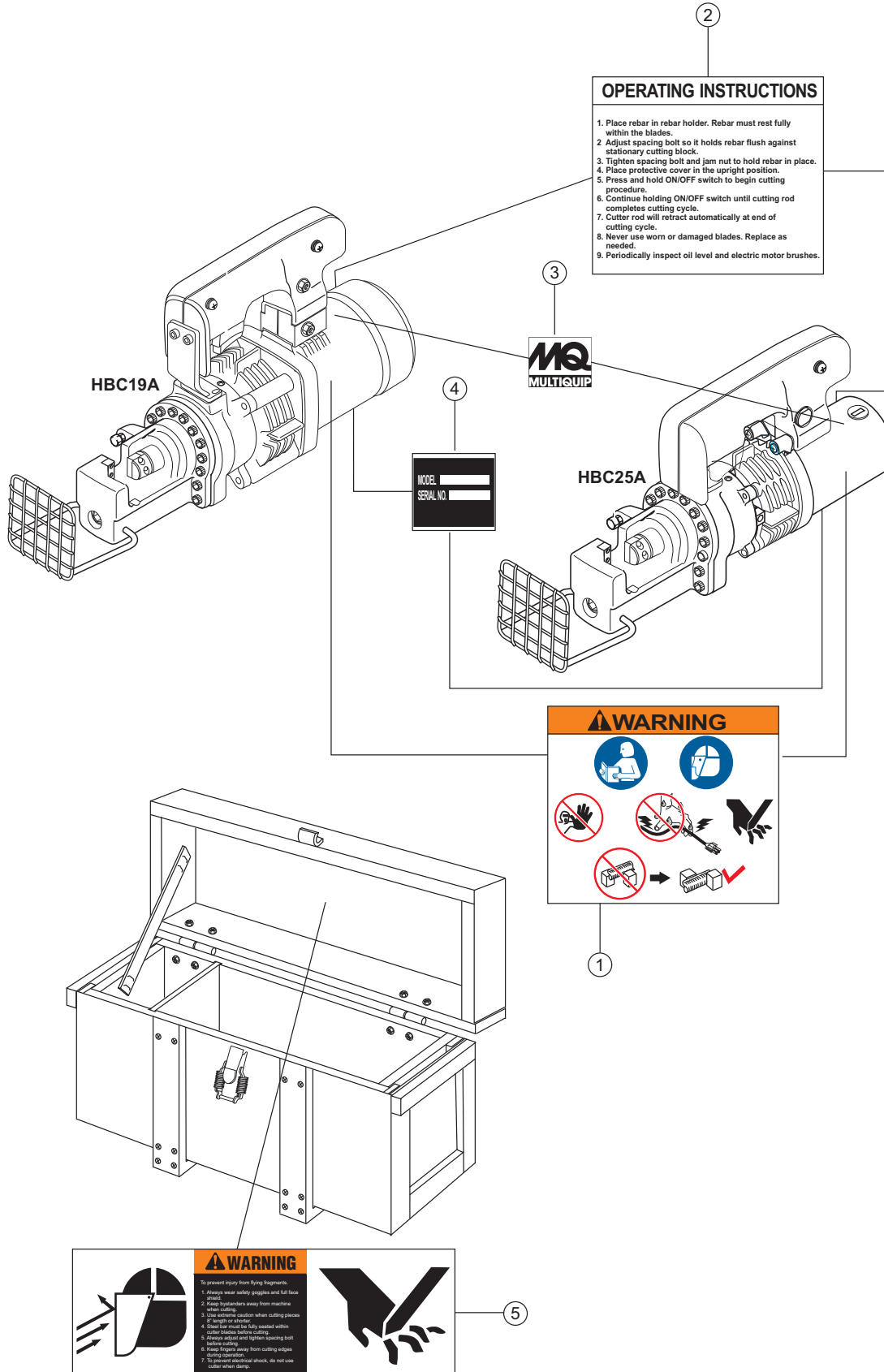

HBC19A/HBC25A — NAMEPLATE AND DECALS

<u>NO.</u>	<u>PART NO.</u>	<u>PART NAME</u>	<u>QTY.</u>	<u>REMARKS</u>
1	8006660	SAFETY WARNING DECAL	1	
2	8006670	OPERATING INSTRUCTIONS DECAL	1	
3	8006680	MQ LOGO	1	
4		NAMEPLATE	1 CONTACT MQ PARTS DEPT.
5	8001180	BOX WARNING DECAL	1	

HBC19A — REBAR CUTTER ASSEMBLY

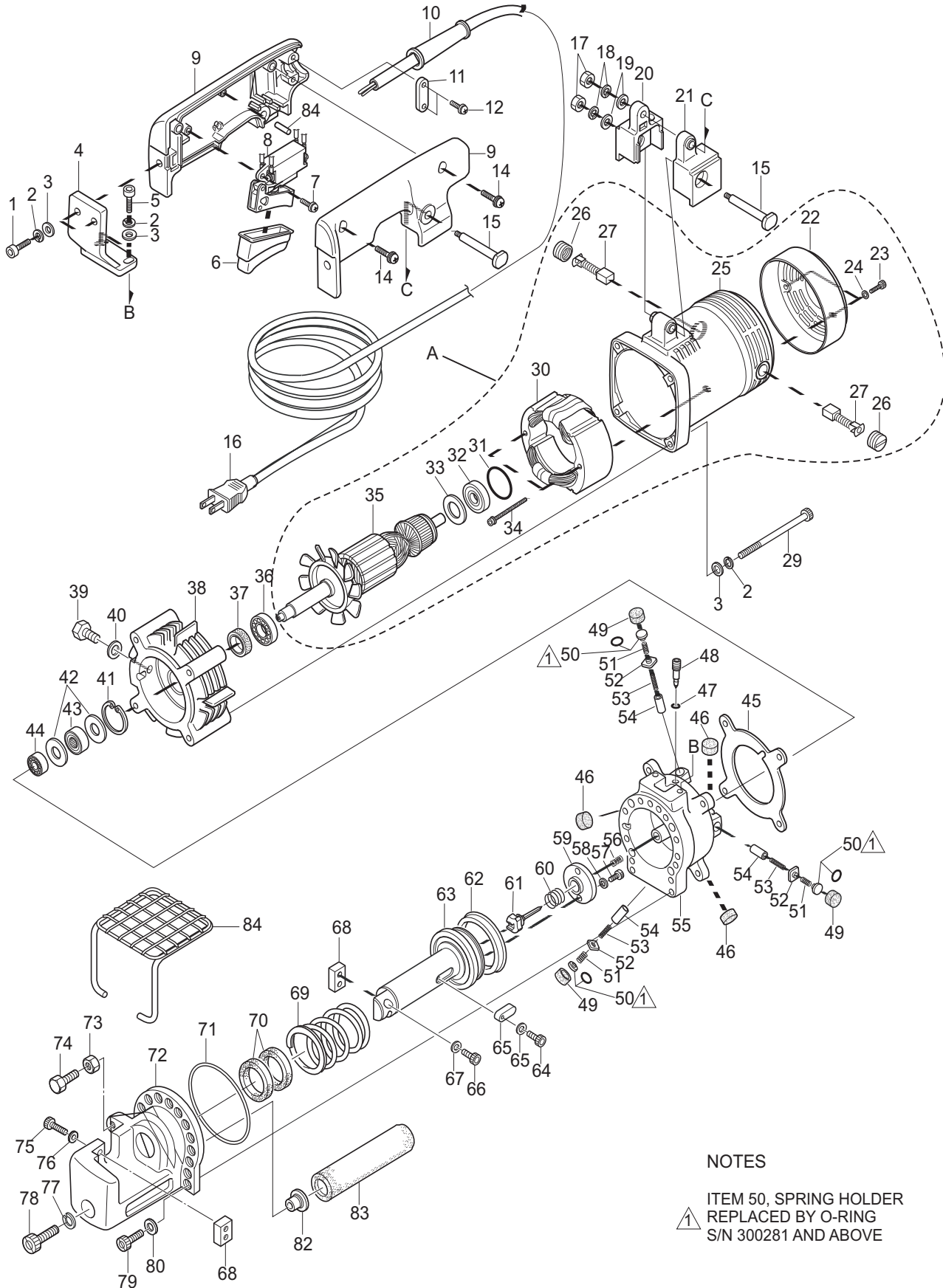

NOTES

- ITEM 50, SPRING HOLDER
REPLACED BY O-RING
S/N 300281 AND ABOVE

HBC19A — REBAR CUTTER ASSEMBLY

<u>NO.</u>	<u>PART NO.</u>	<u>PART NAME</u>	<u>QTY.</u>	<u>REMARKS</u>
1	7513090	BOLT HB6 X 22	2	
2	030208200	SPRING WASHER SW6	8	REPLACES H9SW060100
3	7600030	WASHER WM6	8	
4	4500720	HANDLE BRACKET A	1	
5	H9HB062000	BOLT HB6 X 20	2	
6	6415810	DUST COVER	1	
7	6415820	PAN-HEAD SCREW M4 x 16	1	
8	6415880	SWITCH	1	
9	6415750	HANDLE SET (PAIR)	1	SET OF 2 (LEFT AND RIGHT)
10	6415910	STRAIN RELIER 10	1	
11	6415930	CORD CLAMP WASHER	1	
12	6415830	PAN-HEAD SCREW M4 x 18WR	2	
14	6415840	PAN-HEAD SCREW M5 X 25	2	
15	6415010	HANDLE SHAFT	2	
16	6301430	ELECTRIC SUPPLY CORD	1	
17	6415040	NUT M6	2	
18	6415030	SPRING WASHER 6	2	
19	6415020	WASHER 6	2	
20	4500730	HANDLE BRACKET R	1	
21	4500740	HANDLE BRACKET L	1	
22#	6415800	HALF OPEN COVER	1	
23#	6415860	BOLT M5 X 16	2	
24#	6415870	SPRING WASHER 5	2	
25#	6415740	MOTOR HOUSING SET	1	
26#	6415710	BRUSH CAP	2	
27#	6415730	CARBON BRUSH 155 (SET)	1	
29	7513160	BOLT HB6 X 85	4	
30#	6415510	STATOR 115V	1	
31#	6415770	O-RING 30	1	
32#	6415760	BALL BEARING 6200DDW	1	
33#	6415940	WASHER	1	
34#	6415790	BOLT M5 X 55	2	
35#	6415610	ARMATURE 115V	1	
36	H9B6202RU0	BEARING 6202RU	1	
37	H9MHS15257	OIL SEAL MHS15257	1	
38	3214000	PUMP CASE	1	
39	H9SB101500	BOLT SB 10 X 15 (DRAINING/REFILLING)	1	
40	H9SEALW100	SEAL WASHER (DRAINING/REFILLING)	1	
41	7411070	STOP RING H28 (RTW28)	1	
42	H9T4344700	NEEDLE HOLDER	2	
43	H9B12410A0	NEEDLE BEARING	1	
44	H9B6080000	BEARING 608	1	
45	4601570	LINER B	1	
46	H9T4344800	MAGNET	3	
47	6505300	O-RING S-4	1	

HBC19A — REBAR CUTTER ASSEMBLY

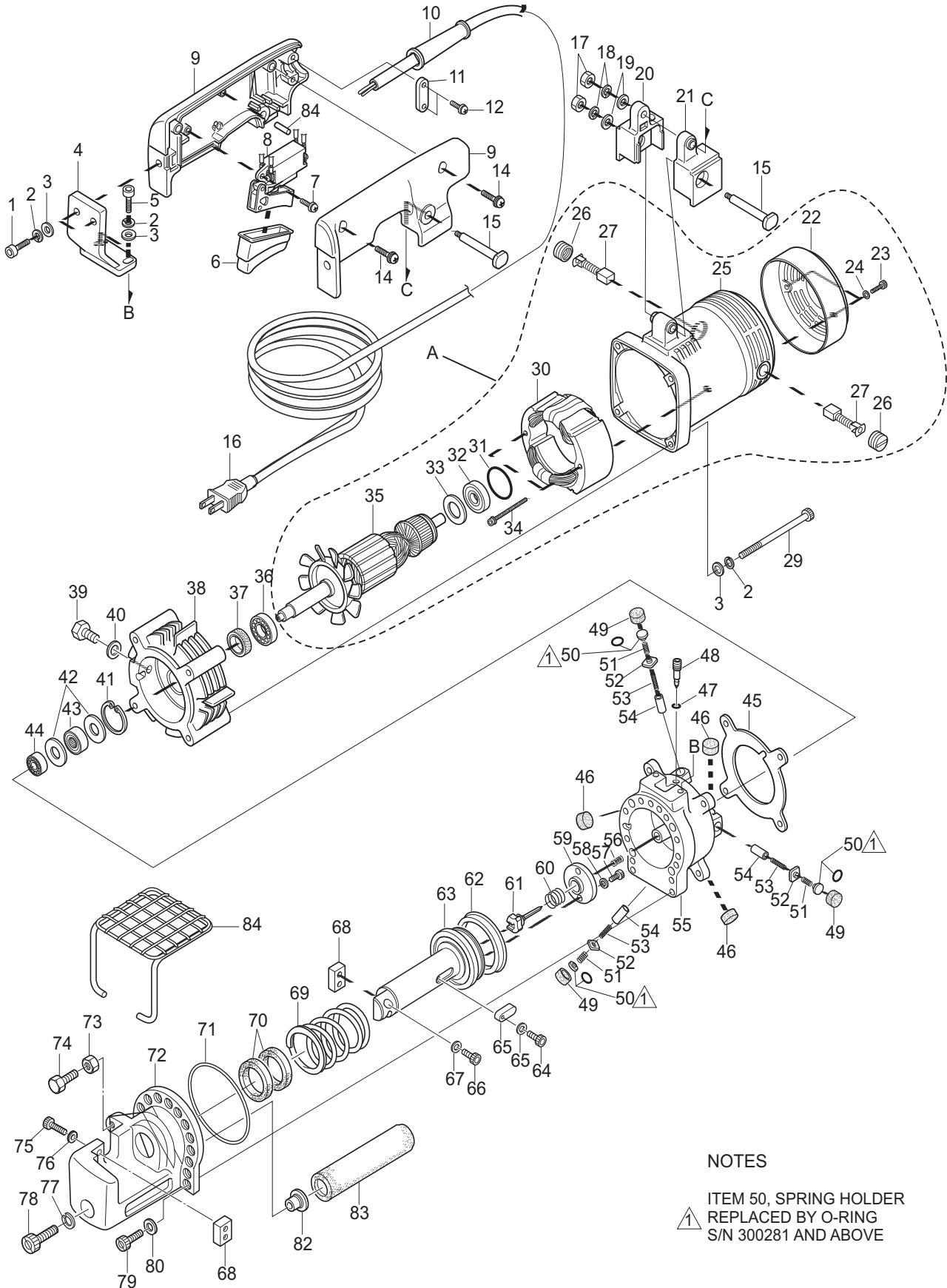

HBC19A — REBAR CUTTER ASSEMBLY

<u>NO.</u>	<u>PART NO.</u>	<u>PART NAME</u>	<u>QTY.</u>	<u>REMARKS</u>
48	3501420	RETURN VALVE	1	
49	H9T4424800	URETHANE RUBBER PACKING	3	S/N 300280 AND BELOW
49	4500530	PACKING	3	S/N 300281 AND ABOVE
50	H9T43446N1	SPRING HOLDER	3	S/N 300280 AND BELOW
50	6505590	O-RING	3	S/N 300281 AND ABOVE
51	H9T43449N1	CHECK VALVE SPRING	3	
52	H9T4344500	CHECK VALVE	3	
53	H9T4345000	PISTON RETURN SPRING	3	
54	3500350	PISTON	3	
55	3200940	CYLINDER	1	S/N 300280 AND BELOW
55	3200940A	CYLINDER	1	S/N 300281 AND ABOVE
56	H9T43679N1	RELEASE VALVE SPRING	1	
57	H9HB040600	BOLT HB4 X 6	2	
58	H9HW040100	WASHER HW4	3	
59	H9T4367700	STOPPER PLATE	1	
60	4005050	VALVE RETURN SPRING	1	
61	H9T44078N2	RELEASE VALVE	1	
62	H9USI00200	PACKING	1	
63	H9T44061N1	CUTTER ROD	1	
64	7511010	BOLT HB4 X 8	1	
65	H9T43898N1	CUTTER ROD KEY	1	
66\$	H9HB051500	BOLT HB5 X15 (BLADE-CUTTER ROD)	2	
67\$	H9HW050000	WASHER HW5	2	
68	H9T4495400	BLADE (SET OF 2)	1	INCLUDES ITEMS W/ \$
69	H9T4389700	CUTTER ROD RETURN SPRING	1	
70	H9USH00100	ROD SEAL PACKING	2	
71	6505700	O-RING S-95	1	
72	3100240	BAR HOLDER	1	
73	H9NM1201M0	NUT NM12-1 (SPACING BOLT)	1	
74	H9T43902N1	SPACING BOLT	1	
75\$	7513030	BOLT HB6 X 18 (BLADE-BAR HOLDER)	2	
76\$	H9HW060100	WASHER HW6 (BLADE-BAR HOLDER)	2	
77	H6SW100100	WASHER SW10	1	
78	H9T4390100	BOLT (OIL LEVELER SACK)	1	
79	H9HB082500	BOLT HB8 X 25 (BAR HOLDER)	14	
80	H9HW080100	WASHER HW8	14	
82	H9T4390000	BUSHING	1	
83	H9T43899N1	OIL LEVELER SACK	1	
84	3505510	PROTECTIVE COVER	1	
A	6013530	MOTOR ASSEMBLY	1	INCLUDES ITEMS W/ #

HBC25A — REBAR CUTTER ASSEMBLY

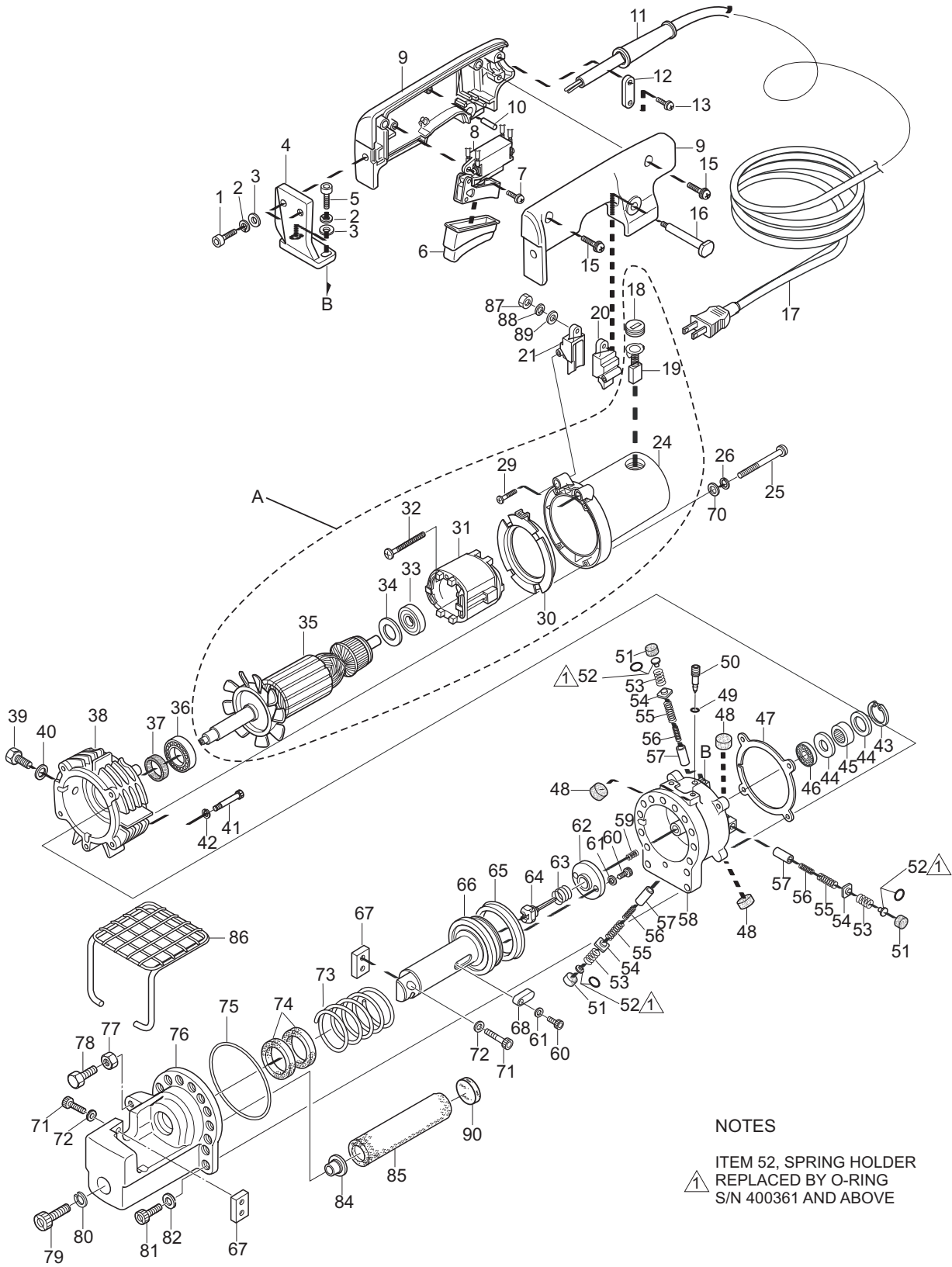

HBC25A — REBAR CUTTER ASSEMBLY

<u>NO.</u>	<u>PART NO.</u>	<u>PART NAME</u>	<u>QTY.</u>	<u>REMARKS</u>
1	7513090	BOLT HB6 X 22	2	
2	H9SW06100	SPRING WASHER SW6	4	
3	7600030	WASHER WM6	4	
4	4500750	HANDLE BRACKET A	1	
5	H6HB062000	BOLT HB6 X 20	2	
6	6415810	DUST COVER	1	
7	6415820	PAN-HEAD SCREW M4 X 16	1	
8	6415880	SWITCH	1	
9	6415750	HANDLE SET (PAIR)	1 SET OF 2 (LEFT AND RIGHT)
10	6400770	RUBBER PIN	2	
11	6415910	STRAIN RELIER 10	1	
12	6415930	CORD CLAMP WASHER	1	
13	6415830	PAN-HEAD SCREW M4 X 18WR	2	
15	6415840	PAN-HEAD SCREW M5 X 25	2	
16	6415010	HANDLE SHAFT	1	
17	6301430	ELECTRIC SUPPLY CORD	1	
18#	6402520	BRUSH CAP	1	
19#	6402510	CARBON BRUSH	1	
20	4500760	HANDLE BRACKET (R)	1	
21	4500770	HANDLE BRACKET (L)	1	
24#	6402450	MOTOR HOUSING SET	1	
25	7512100	BOLT HB5 X 40	4	
26	7610030	SPRING WASHER SW5	4	
29#	7539080	BOLT M6 X 30	2	
30#	6402380	MOTOR FLANGE	1	
31#	6402420	STATOR 115V	1	
32#	6402390	BOLT M5 X 80	1	
33#	7105020	BALL BEARING	1	
34#	6402320	WASHER	1	
35#	6402610	ARMATURE 115V	1	
36	H5B60032RC	BEARING 6003 2RS	1	
37	6504170	OIL SEAL MHS17287	1	
38	3210810	PUMP CASE	1	
39	H6SB101500	BOLT SB10 X 15 (DRAINING/REFILLING)	1	
40	H9SEALW100	SEAL WASHER (DRAINING/REFILLING)	1	
41	7513110	BOLT HB6 X 55	4	
42	H6HW060100	WASHER HW6	4	
43	H5RTW30000	STOP RING H30 (RTW30)	1	
44	H5T4438500	NEEDLE HOLDER	2	
45	H9B12410A0	NEEDLE BEARING	1	
46	H9B6080000	BEARING 608	1	
47	4601590	LINER B	1	
48	H9T4344800	MAGNET	3	
49	6505300	O-RING S-4	1	

HBC25A — REBAR CUTTER ASSEMBLY

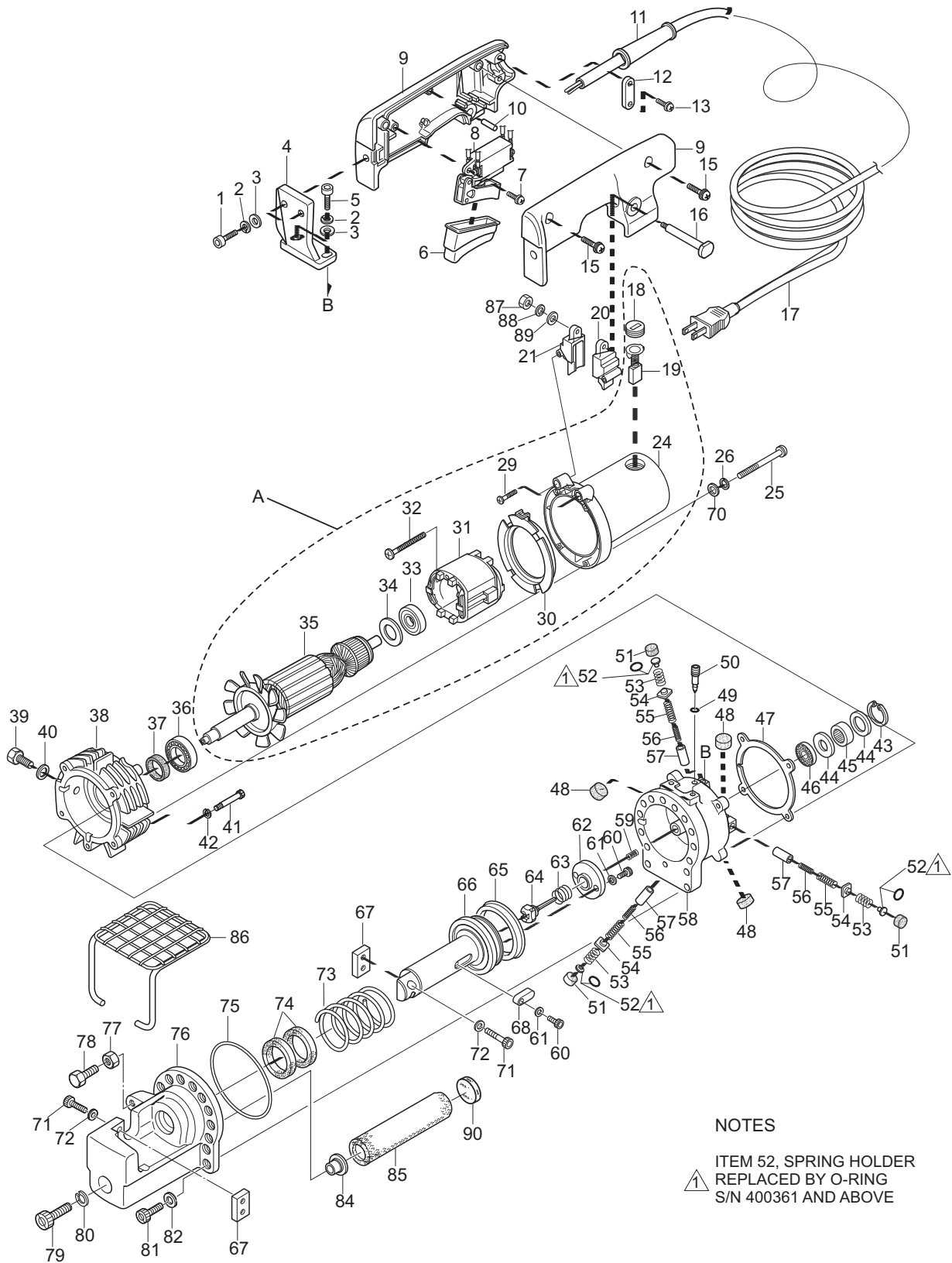

NOTES

 ITEM 52, SPRING HOLDER
 REPLACED BY O-RING
 S/N 400361 AND ABOVE

HBC25A — REBAR CUTTER ASSEMBLY

<u>NO.</u>	<u>PART NO.</u>	<u>PART NAME</u>	<u>QTY.</u>	<u>REMARKS</u>
50	3501420	RETURN VALVE	1	
51	H9T4424800	URETHANE RUBBER PACKING	3	S/N 400360 AND BELOW
51	4500530	PACKING	3	S/N 400361 AND ABOVE
52	H9T43446N1	SPRING HOLDER	3	S/N 400360 AND BELOW
52	6505590	O-RING	3	S/N 400361 AND ABOVE
53	H9T43449N1	CHECK VALVE SPRING	3	
54	H5T4438400	CHECK VALVE	3	
55	H5T4506600	PISTON RETURN SPRING A	3	
56	H5T4506700	PISTON RETURN SPRING B	3	
57	H5T4438300	PISTON	3	
58	3201320	CYLINDER	1	S/N 400360 AND BELOW
58	3201320A	CYLINDER	1	S/N 400361 AND ABOVE
59	H5T4420300	RELEASE VALVE SPRING	1	
60	H5HB051000	BOLT HB5 X10	3	
61	H5HW050100	WASHER HW5	3	
62	H5T4419600	STOPPER PLATE	1	
63	H5T44195N1	VALVE RETURN SPRING	1	
64	H5T44201N2	RELEASE VALVE	1	
65	H5USI00200	PACKING	1	
66	H5T31153N2	CUTTER ROD D40	1	
67	H5T4495500	SP BLADE (SET OF 2)	1	INCLUDES ITEMS W/ \$
68	H5T44194N1	CUTTER ROD KEY	1	
70	7600020	WASHER WM5	4	
71\$	H5HB062000	BOLT HB8 X 20	4	
72\$	H5HW080100	WASHER HW8	4	
73	H5T4419800	CUTTER ROD RETURN SPRING	1	
74	H5USH15257	ROD SEAL PACKING	2	
75	6505240	O-RING (S115)	1	
76	3100500	BAR HOLDER	1	
77	7700070	NUT NM16	1	
78	H5T44200N1	SPACING BOLT	1	
79	H9T4390100	BOLT (OIL LEVELER SACK)	1	
80	H6SW100100	WASHER SW10	1	
81	7515040	BOLT HB10 X 30	14	
82	H5HW100100	WASHER HW10	14	
84	H9T4390000	BUSHING	1	
85	9004920	OIL LEVELER SACK	1	
86	3505520	PROTECTIVE COVER	1	
87	6415040	NUT M6	1	
88	6415030	SPRING WASHER 6	1	
89	6415020	WASHER 6	1	
90	4500540	SHIELD	1	S/N 400301 AND ABOVE
A	6014150	MOTOR ASSEMBLY	1	INCLUDES ITEMS W/ #

HBC19A/HBC25A — TOOLS

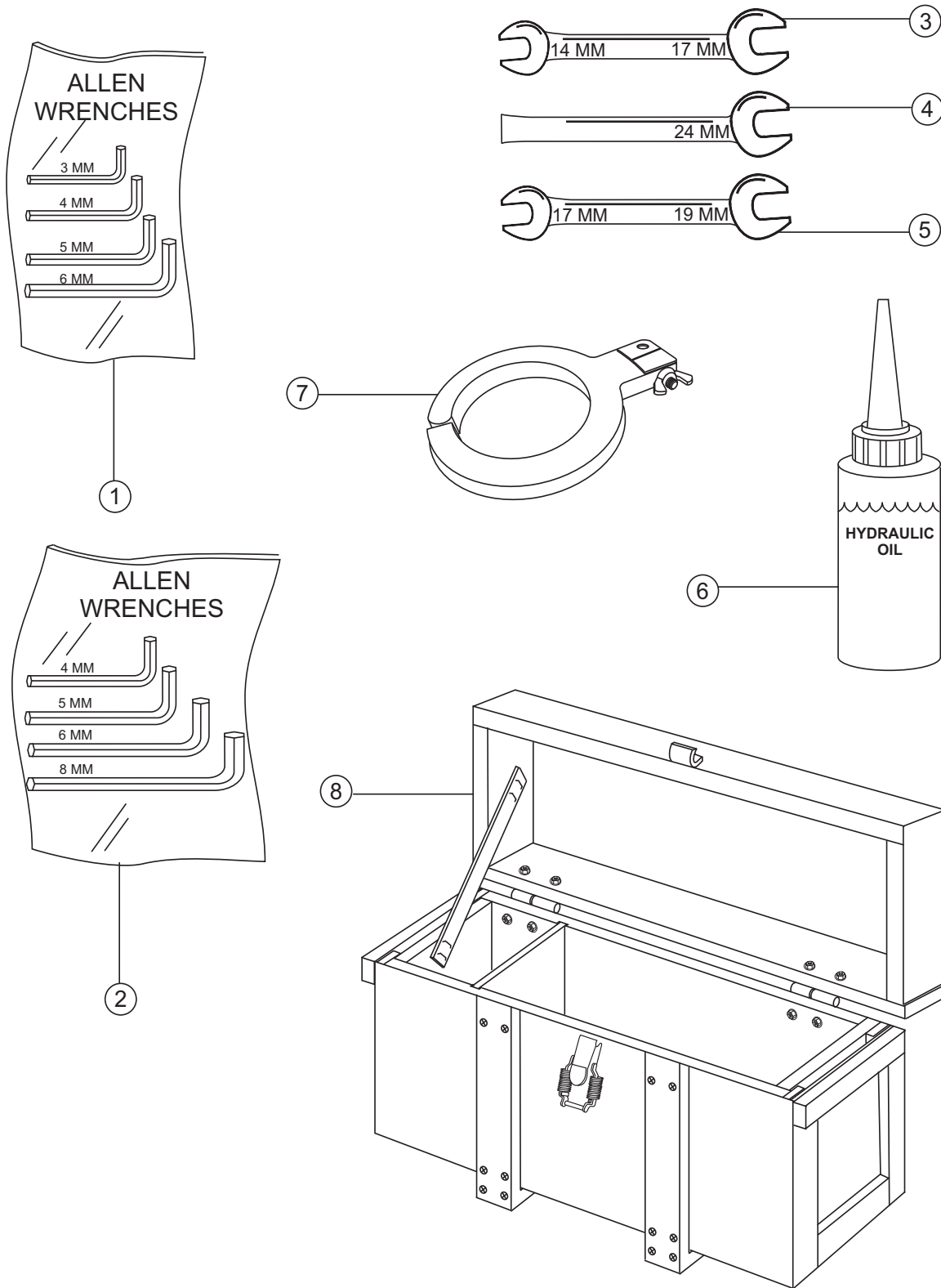

HBC19A/HBC25A — TOOLS

<u>NO.</u>	<u>PART NO.</u>	<u>PART NAME</u>	<u>QTY.</u>	<u>REMARKS</u>
1		ALLEN WRENCH SET, HBC19A	1	REPLACE LOCALLY
2		ALLEN WRENCH SET, HBC25A	1	REPLACE LOCALLY
3	8201010	OPEN WRENCH (14mm X17mm), HBC25A	1	
4	8201070	OPEN WRENCH (24mm), HBC25A	1	
5	8201020	OPEN WRENCH (17mm X19mm), HBC19A	1	
6		HYDRAULIC OIL W/ OILER (150 ml), HBC19A ..	1	SUPPLIED WITH UNIT
6	H9OILIS046	HYDRAULIC OIL W/ OILER (1 liter), HBC19A	1	REPLACEMENT PART
6		HYDRAULIC OIL W/ OILER (150 ml), HBC25A ..	1	SUPPLIED WITH UNIT
6	H5OILIS032	HYDRAULIC OIL W/ OILER (1 liter), HBC25A	1	REPLACEMENT PART
7	H9J2387000	CYLINDER RING (TOOL), HBC19A	1	NOT PROVIDED W/ UNIT
7	9004040	CYLINDER RING (TOOL), HBC25A	1	NOT PROVIDED W/ UNIT
8	8101050	WOODEN BOX, HBC25A	1	
8	8101060	WOODEN BOX, HBC19A	1	

HBC19A/HBC25A — WIRING DIAGRAM

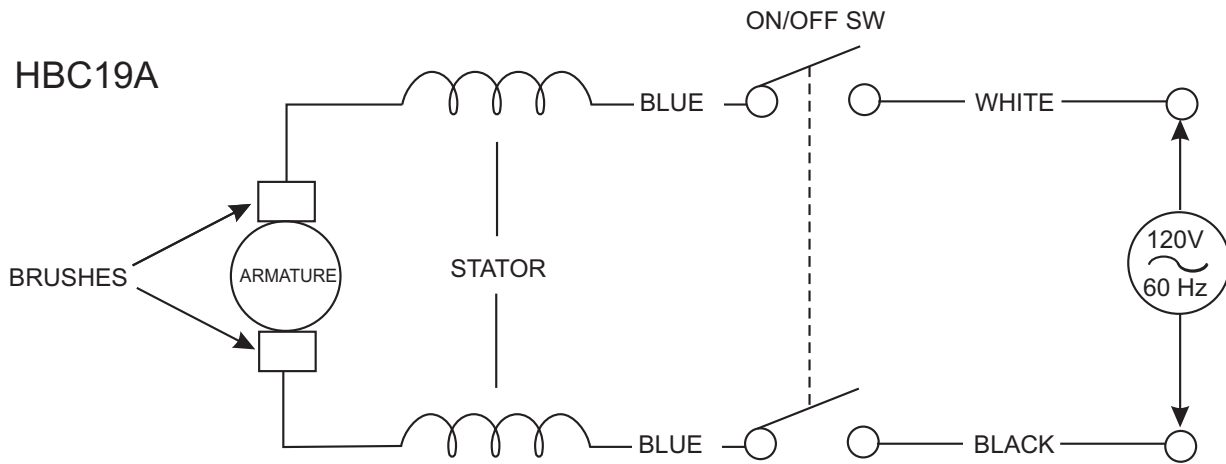
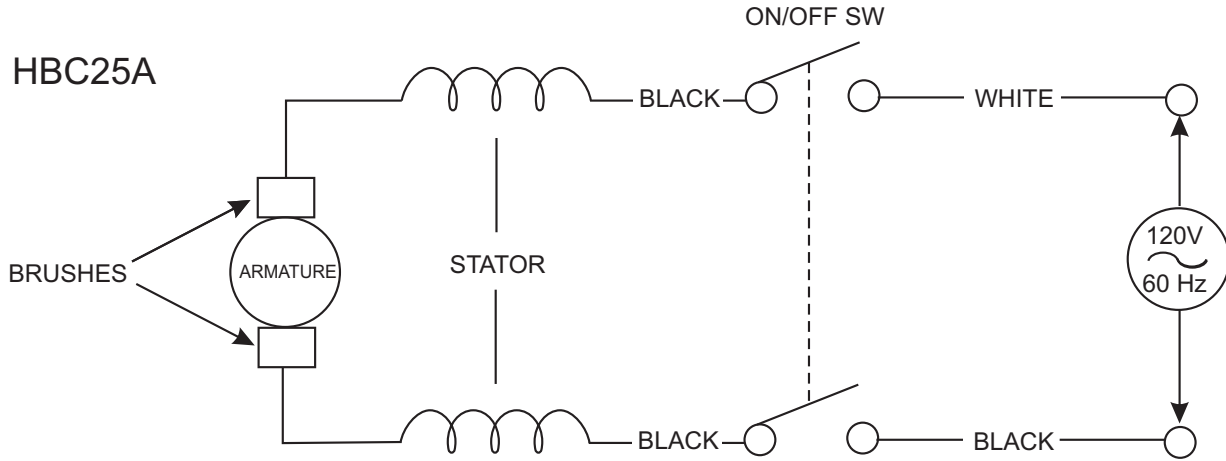

TERMS AND CONDITIONS OF SALE — PARTS

PAYMENT TERMS

Terms of payment for parts are net 30 days.

FREIGHT POLICY

All parts orders will be shipped collect or prepaid with the charges added to the invoice. All shipments are F.O.B. point of origin. Multiquip's responsibility ceases when a signed manifest has been obtained from the carrier, and any claim for shortage or damage must be settled between the consignee and the carrier.

MINIMUM ORDER

The minimum charge for orders from Multiquip is \$15.00 net. Customers will be asked for instructions regarding handling of orders not meeting this requirement.

RETURNED GOODS POLICY

Return shipments will be accepted and credit will be allowed, subject to the following provisions:

1. A Returned Material Authorization must be approved by Multiquip prior to shipment.
2. To obtain a Return Material Authorization, a list must be provided to Multiquip Parts Sales that defines item numbers, quantities, and descriptions of the items to be returned.
 - a. The parts numbers and descriptions must match the current parts price list.
 - b. The list must be typed or computer generated.
 - c. The list must state the reason(s) for the return.
 - d. The list must reference the sales order(s) or invoice(s) under which the items were originally purchased.
 - e. The list must include the name and phone number of the person requesting the RMA.
3. A copy of the Return Material Authorization must accompany the return shipment.
4. Freight is at the sender's expense. All parts must be returned freight prepaid to Multiquip's designated receiving point.

5. Parts must be in new and resalable condition, in the original Multiquip package (if any), and with Multiquip part numbers clearly marked.
6. The following items are not returnable:
 - a. Obsolete parts. (If an item is in the price book and shows as being replaced by another item, it is obsolete.)
 - b. Any parts with a limited shelf life (such as gaskets, seals, "O" rings, and other rubber parts) that were purchased more than six months prior to the return date.
 - c. Any line item with an extended dealer net price of less than \$5.00.
 - d. Special order items.
 - e. Electrical components.
 - f. Paint, chemicals, and lubricants.
 - g. Decals and paper products.
 - h. Items purchased in kits.
7. The sender will be notified of any material received that is not acceptable.
8. Such material will be held for five working days from notification, pending instructions. If a reply is not received within five days, the material will be returned to the sender at his expense.
9. Credit on returned parts will be issued at dealer net price at time of the original purchase, less a 15% restocking charge.
10. In cases where an item is accepted, for which the original purchase document can not be determined, the price will be based on the list price that was effective twelve months prior to the RMA date.
11. Credit issued will be applied to future purchases only.

PRICING AND REBATES

Prices are subject to change without prior notice. Price changes are effective on a specific date and all orders received on or after that date will be billed at the revised price. Rebates for price declines and added charges for price increases will not be made for stock on hand at the time of any price change.

Multiquip reserves the right to quote and sell direct to Government agencies, and to Original Equipment Manufacturer accounts who use our products as integral parts of their own products.

SPECIAL EXPEDITING SERVICE

A \$35.00 surcharge will be added to the invoice for special handling including bus shipments, insured parcel post or in cases where Multiquip must personally deliver the parts to the carrier.

LIMITATIONS OF SELLER'S LIABILITY

Multiquip shall not be liable hereunder for damages in excess of the purchase price of the item with respect to which damages are claimed, and in no event shall Multiquip be liable for loss of profit or good will or for any other special, consequential or incidental damages.

LIMITATION OF WARRANTIES

No warranties, express or implied, are made in connection with the sale of parts or trade accessories nor as to any engine not manufactured by Multiquip. Such warranties made in connection with the sale of new, complete units are made exclusively by a statement of warranty packaged with such units, and Multiquip neither assumes nor authorizes any person to assume for it any other obligation or liability whatever in connection with the sale of its products. Apart from such written statement of warranty, there are no warranties, express, implied or statutory, which extend beyond the description of the products on the face hereof.

Effective: February 22, 2006

OPERATION AND PARTS MANUAL

HERE'S HOW TO GET HELP

PLEASE HAVE THE MODEL AND SERIAL
NUMBER ON-HAND WHEN CALLING

UNITED STATES

Multiquip Corporate Office

18910 Wilmington Ave. Tel. (800) 421-1244
Carson, CA 90746 Fax (800) 537-3927
Contact: mq@multiquip.com

Mayco Parts

800-306-2926 Fax: 800-672-7877
310-537-3700 Fax: 310-637-3284

Service Department

800-421-1244 Fax: 310-537-4259
310-537-3700

MQ Parts Department

800-427-1244 Fax: 800-672-7877
310-537-3700 Fax: 310-637-3284

Warranty Department

800-421-1244, Ext. 279 Fax: 310-537-1173
310-537-3700, Ext. 279

Technical Assistance

800-478-1244 Fax: 310-631-5032

MEXICO

MQ Cipsa

Carr. Fed. Mexico-Puebla KM 126.5 Tel: (52) 222-225-9900
Momoxpan, Cholula, Puebla 72760 Mexico Fax: (52) 222-285-0420
Contact: pmastretta@cipsa.com.mx

UNITED KINGDOM

Multiquip (UK) Limited Head Office

Hanover Mill, Fitzroy Street, Tel: 0161 339 2223
Ashton-under-Lyne, Fax: 0161 339 3226
Lancashire OL7 0TL
Contact: sales@multiquip.co.uk

CANADA

Multiquip

4110 Industriel Boul. Tel: (450) 625-2244
Laval, Quebec, Canada H7L 6V3 Fax: (450) 625-8664
Contact: jmartin@multiquip.com

© COPYRIGHT 2009, MULTIQUIP INC.

Multiquip Inc and the MQ logo are registered trademarks of Multiquip Inc. and may not be used, reproduced, or altered without written permission. All other trademarks are the property of their respective owners and used with permission.

This manual MUST accompany the equipment at all times. This manual is considered a permanent part of the equipment and should remain with the unit if resold.

The information and specifications included in this publication were in effect at the time of approval for printing. Illustrations, descriptions, references and technical data contained in this manual are for guidance only and may not be considered as binding. Multiquip Inc. reserves the right to discontinue or change specifications, design or the information published in this publication at any time without notice and without incurring any obligations.

Your Local Dealer is:

