



The information and specifications included in this publication were in effect at the time of approval for printing. Illustrations, descriptions, references and technical data contained in this document are for guidance only and may not be considered as binding. Multiquip Inc. reserves the right to discontinue or change specifications, design or the information published in this publication at any time without notice and without incurring any obligations.

CVT LOWER PULLEY COUPLER CHANGE

Multiquip has released an improvement via running production change for the coupler on the lower CVT pulley. The improved coupler helps minimize vibrations and run-out of the rotating assembly.

This change is effective immediately on Models HHNG5 and HHXDF5 **Starting S/N MF0211163**, all unit's produced after this serial number will have the new coupler installed.

Part number for the coupler (**MQ P/N 23433 HHNG5 MQ P/N 23420 HHXDF5**) remains the same. These new couplers for both models are backward compatible to all existing units in the field. Units that have this coupler no longer use the spacer MQ P/N 30110. **It is recommended that the coupler be changed to this new design anytime a cross shaft assembly, lower CVT pulley or left side axle is serviced.**

The new improved coupler will have a raised area, (ref. A) in the following image. It will fit into the Lower CVT pulley allowing the coupler to be centered onto the assembly.

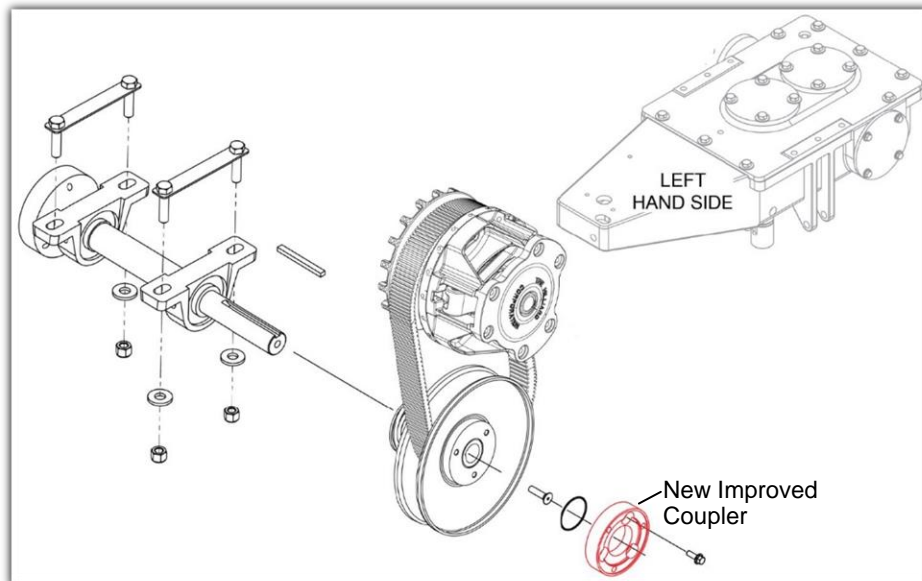

© COPYRIGHT 2022, MULTIQIP INC., Rev. 0 (09092022)