



Service Bulletin

HTXG6DF, HTXD6i And STXD6i Hydrostatic Ride-On Trowels Spider Retaining Bolt Replacement And Spider Hub Cleaning

Product Group: Ride-On Trowels	Date Issued: 06/02/16	Service Bulletin No. TR20160601
Bulletin Type		Models/Series Affected:
<input checked="" type="checkbox"/> Mandatory <input type="checkbox"/> Information Only <input type="checkbox"/> Recommended Change		HTXG6DF S/N PA2003116 — PB2003172 HTXD6i S/N PA2003106 — PC2003212 STXD6i S/N PA2003099 — PC2003207

Details
<p>Problems:</p> <ol style="list-style-type: none"> Spinning of the spider hub on the tapered shaft of the hydraulic motor is due to the hub and the hydraulic motor shaft not being cleaned properly. Existing spider retaining screw is too long (insufficient screw clearance). <p>Solutions:</p> <ol style="list-style-type: none"> If required, thoroughly clean female threads on hydraulic motor tapered shaft. If required, thoroughly clean tapered orifice on spider hub. Replace existing left and right spider retaining screws with new 2-1/4 inch screws.

Parts Information															
<table border="1"> <thead> <tr> <th>Item No.</th> <th>Part No.</th> <th>Description</th> <th>QTY.</th> <th>Remarks</th> </tr> </thead> <tbody> <tr> <td>1</td> <td>32788</td> <td>Screw, HHC 3/4-16 x 2-1/4" GRD 8 YEL ZIN</td> <td>2</td> <td></td> </tr> <tr> <td>2</td> <td>19379-014</td> <td>Red Loctite™ 271</td> <td>2</td> <td></td> </tr> </tbody> </table>	Item No.	Part No.	Description	QTY.	Remarks	1	32788	Screw, HHC 3/4-16 x 2-1/4" GRD 8 YEL ZIN	2		2	19379-014	Red Loctite™ 271	2	
Item No.	Part No.	Description	QTY.	Remarks											
1	32788	Screw, HHC 3/4-16 x 2-1/4" GRD 8 YEL ZIN	2												
2	19379-014	Red Loctite™ 271	2												

WORK SAFELY!

Only a **qualified service technician** with proper training should perform this installation. Follow all shop safety rules when performing this installation.

REQUIRED TOOLS

- Torque Wrench
- Hammer
- Air Compressor
- Spider Removal Tool (If Required P/N 32194)
- Chemsearch™ (Rust Lubricant)
- Forklift/Hoist
- Heavy Duty Jack Stands

Procedure

This procedure will consist of **three different scenarios** as referenced below:

Scenario #1

If your trowel has **less than** 20 hours of operation time, both spiders need to be removed, cleaned and reinstalled with the **new** 2-1/4" screws (P/N 32788).

Scenario #2

If your trowel has **more than** 20 hours of operation time, check that both spider retaining screws are torqued to 350 ft-lb (475 N·m). If either one of the 2 spider bolts is less than the specified value, then both spiders need to be removed, cleaned and reinstalled with the **new** 2-1/4" screws (P/N 32788).

Scenario #3

If your trowel has **more than** 20 hours of operation time, and both spider retaining bolts are torqued to 350 ft-lb (475 N·m), simply remove both existing spider retaining screws and replace with the **new** 2-1/4" screws (P/N 32788).

LIFTING THE TROWEL

1. Attach one end of a lifting strap or chain around the lift loops on each side of the trowel. Attach the other end of the lifting strap or chain to the lifting device (Figure 1).

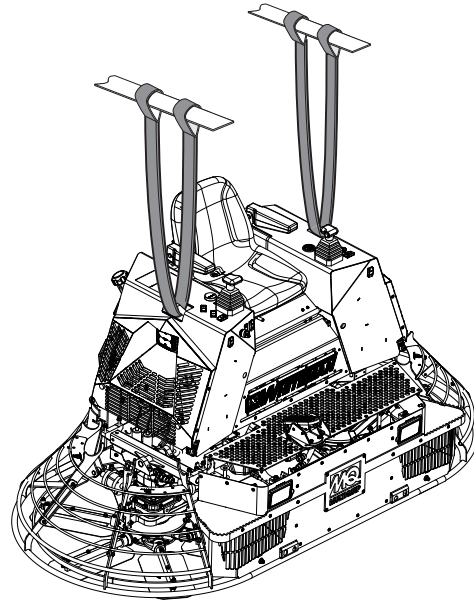

Figure 1. Lifting the Trowel

2. Next, place the trowel on heavy duty jack stands as shown in Figure 2.

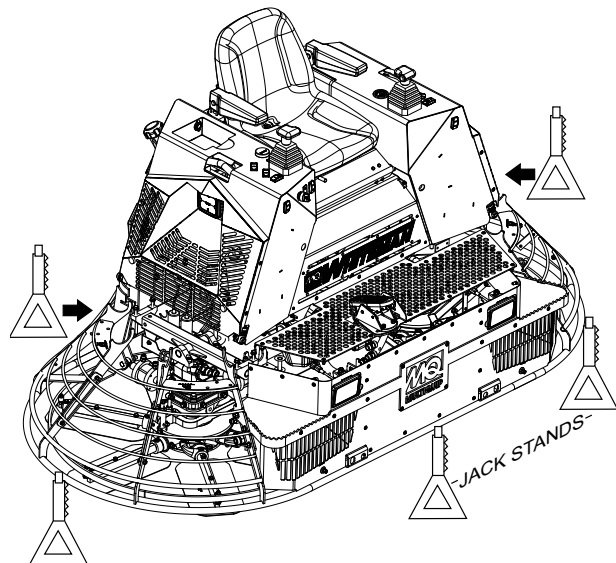

Figure 2. Jack Stand Support

SPIDER REMOVAL (Scenario's 1 and 2 Only)

CAUTION

The spider removal process will result in the sudden separation of the spider assembly from the hydraulic motor shaft.

Position the catch chains so that they are equally spaced, with no more than 3 to 4 inches of slack. This will prevent the spider assembly from falling and striking personnel, causing bodily harm. The catch chains shown in Figure 3 are shorter than they appear. They are shown this way for clarity only.

1. Attach one end of three equally spaced straps or catch chains to the **stabilizer ring** (Figure 3). Attach the other end of these straps or chains to the **bottom guard ring** in a manner that would prevent the spider assembly from falling **NEVER** use the **intermediate guard rings** to support the spider assembly.

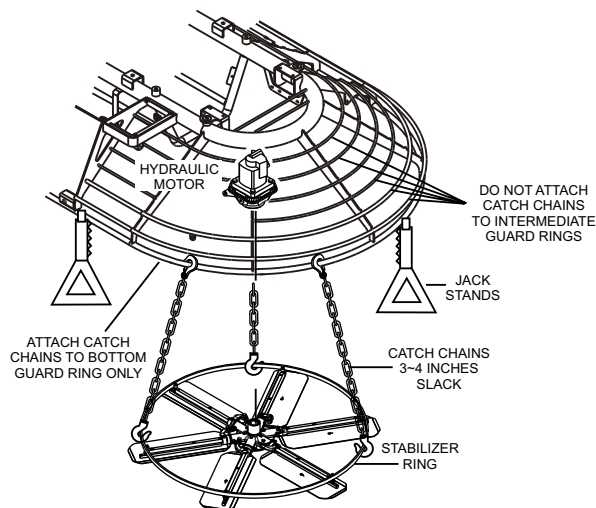

Figure 3. Supporting Stabilizer Ring

2. To assist with the removal of the spider assembly, threads for a removal tool have been machined into the bottom center of the spider.
3. Remove the snap-in spider dust cover plug from the bottom of the spider. This plug has been provided to protect the spider threads from contaminants.
4. Remove the existing left and right side spider retaining screws and washers. Discard both retaining screws. Keep both washers they will be used later.
5. When separating the spider assembly from the hydraulic motor shaft, apply a small amount of rust lubricant to the threads.

6. Insert spider removal tool (P/N 32194) or equivalent tool into the machined threads on spider hub (Figure 4) and torque to 300 ft-lb (407 N·m).

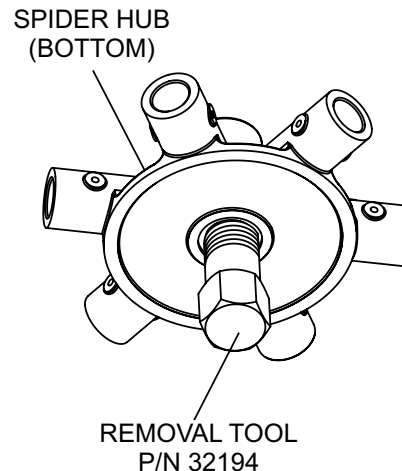

Figure 4. Removal Tool

7. If the spider assembly does not disengage, remove the torque wrench and strike the end of the spider removal tool with a hammer several times to dislodge the spider.
8. Repeat steps 6 and 7 until spider assembly disengages.
9. Once the spider assembly has been removed, place on a flat surface where it will not get damaged. Please note the orientation (left or right) of each spider. Orientation is defined from the operator's seat. Mark and tag each spider either left or right.

NOTICE

IMPORTANT always **mark** and **tag** each spider assembly prior to removing it from the trowel. Left and right is defined from the operator's seat.

SPIDER RETAINING SCREW REMOVAL (Scenario 3 Only)

1. Remove the snap-in spider dust cover plug from the bottom of the spider. This plug has been provided to protect the spider threads from contaminants.
2. Remove the existing left and right side spider retaining screws and washers. Discard both retaining screws. Keep both washers they will be used later.

SPIDER INSTALLATION (Scenario's 1 and 2 Only)

NOTICE

NEVER use any type of anti-seize or lubricant when installing the tapered fit components of the spider onto the hydraulic drive motor shaft.

1. Before re-assembling, ensure that the tapered orifice (Figure 5) in the spider is clean. Spray with brake cleaner to remove any contaminants that may have accumulated on the tapered surface of the spider.

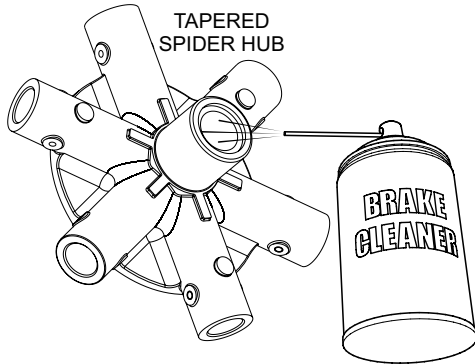

Figure 5. Cleaning Spider Hub Tapered Orifice

2. Use compressed air (Figure 6) to blow away any remaining residue that may have accumulated inside the spider hub orifice.

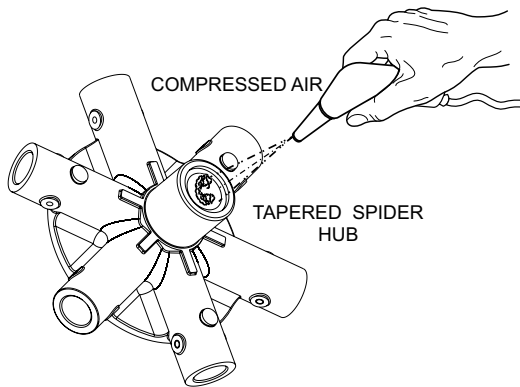

Figure 6. Residue Removal

3. Make sure the threads inside the hydraulic drive motor shaft are clean and free of debris.
4. Spray with brake cleaner to remove any contaminants that may have accumulated on the hydraulic drive motor threads (Figure 7) or output shaft. Use compressed air to blow away any remaining residue.

5. Apply Red Loctite™ 271 (19379-014) to the female threads (Figure 7) on the hydraulic motor shaft.

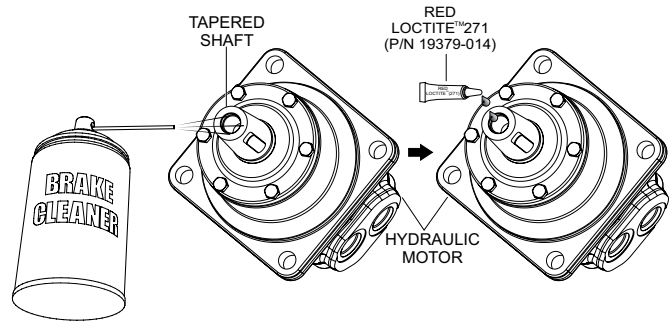

Figure 7. Applying Loctite™ (Hyd. Motor Shaft)

6. Lift tapered spider assembly onto hydraulic motor shaft. This may require two people.

NEW SPIDER RETAINING SCREW INSTALLATION (Scenarios 1, 2 and 3)

1. Place the washer that was removed earlier onto the **new** spider retaining screw (P/N 32788) and insert both items into the hydraulic motor shaft.
2. Using a torque wrench, torque spider retaining bolt to 350 ft-lb (475 N·m).
3. Remove the trowel from the jack-stands and place on a flat surface.
4. Start trowel as referenced in operator's manual. Run trowel for 15 minutes.
5. Lift and place trowel back onto jack-stands.
6. Remove spider retaining screw and apply Red Loctite™ 271 (19379-014) to the screw threads (Figure 8).

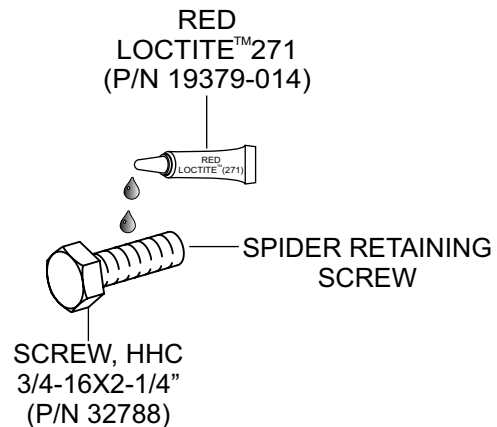

Figure 8. Spider Retaining Screw

7. Insert washer and spider retaining screw into hydraulic motor shaft. Re-torque spider retaining screw to 350 ft-lb (475 N·m).
8. Insert snap-in spider dust cover plug.



Service Bulletin
HTXG6DF, HTXD6i And STXD6i Hydrostatic Ride-On Trowels
Spider Retaining Bolt Replacement And Spider Hub Cleaning

HERE'S HOW TO GET HELP

PLEASE HAVE THE MODEL AND SERIAL
NUMBER ON-HAND WHEN CALLING

UNITED STATES

Multiquip Corporate Office

18910 Wilmington Ave. Tel. (800) 421-1244
Carson, CA 90746 Fax (310) 537-3927
Contact: mq@multiquip.com

Service Department

800-421-1244 Fax: 310-537-4259
310-537-3700

Technical Assistance

800-478-1244 Fax: 310-943-2238

MQ Parts Department

800-427-1244 Fax: 800-672-7877
310-537-3700 Fax: 310-637-3284

Warranty Department

800-421-1244 Fax: 310-943-2249
310-537-3700

CANADA

Multiquip

4110 Industriel Boul. Tel: (450) 625-2244
Laval, Quebec, Canada H7L 6V3 Tel: (877) 963-4411
Contact: infocanda@multiquip.com Fax: (450) 625-8664

UNITED KINGDOM

Multiquip (UK) Limited Head Office

Unit 2, Northpoint Industrial Estate, Tel: 0161 339 2223
Globe Lane, Fax: 0161 339 3226
Dukinfield, Cheshire SK16 4UJ
Contact: sales@multiquip.co.uk

© COPYRIGHT 2016, MULTIQUIP INC.

Multiquip Inc and the MQ logo are registered trademarks of Multiquip Inc. and may not be used, reproduced, or altered without written permission. All other trademarks are the property of their respective owners and used with permission.

The information and specifications included in this publication were in effect at the time of approval for printing. Illustrations, descriptions, references and technical data contained in this document are for guidance only and may not be considered as binding. Multiquip Inc. reserves the right to discontinue or change specifications, design or the information published in this publication at any time without notice and without incurring any obligations.

Your Local Dealer is:

