

# OPERATION AND PARTS MANUAL



## **JWN-SERIES**

# **RIDE-ON POWER TROWEL**

### **HONDA GX670TAF 24 HP ENGINE**

**S/N VB0206951 AND BELOW**

Revision #9 (11/29/16)

To find the latest revision of this  
publication, visit our website at:  
[www.multiquip.com](http://www.multiquip.com)



**THIS MANUAL MUST ACCOMPANY THE EQUIPMENT AT ALL TIMES.**

**P/N 20214**



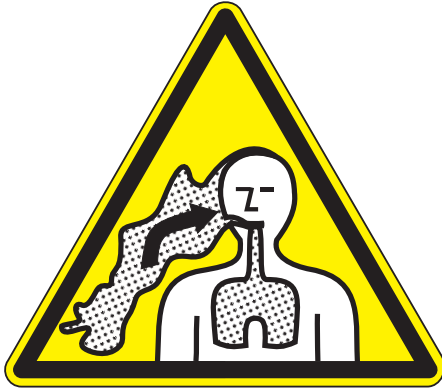
## **CALIFORNIA — Proposition 65 Warning**

Engine exhaust and some of its constituents, and some dust created by power sanding, sawing, grinding, drilling and other construction activities contains chemicals known to the State of California to cause cancer, birth defects and other reproductive harm. Some examples of these chemicals are:

- Lead from lead-based paints.
- Crystalline silica from bricks.
- Cement and other masonry products.
- Arsenic and chromium from chemically treated lumber.

Your risk from these exposures varies, depending on how often you do this type of work. To reduce your exposure to these chemicals: ALWAYS work in a well ventilated area, and work with approved safety equipment, such as dust masks that are specially designed to filter out microscopic particles.

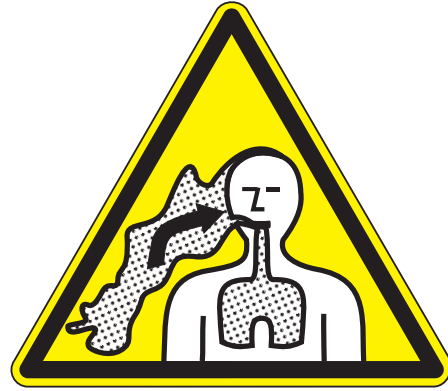
## **WARNING**



### **SILICOSIS WARNING**

Grinding/cutting/drilling of masonry, concrete, metal and other materials with silica in their composition may give off dust or mists containing crystalline silica. Silica is a basic component of sand, quartz, brick clay, granite and numerous other minerals and rocks. Repeated and/or substantial inhalation of airborne crystalline silica can cause serious or fatal respiratory diseases, including silicosis. In addition, California and some other authorities have listed respirable crystalline silica as a substance known to cause cancer. When cutting such materials, always follow the respiratory precautions mentioned above.

## **WARNING**



### **RESPIRATORY HAZARDS**

Grinding/cutting/drilling of masonry, concrete, metal and other materials can generate dust, mists and fumes containing chemicals known to cause serious or fatal injury or illness, such as respiratory disease, cancer, birth defects or other reproductive harm. If you are unfamiliar with the risks associated with the particular process and/or material being cut or the composition of the tool being used, review the material safety data sheet and/or consult your employer, the material manufacturer/supplier, governmental agencies such as OSHA and NIOSH and other sources on hazardous materials. California and some other authorities, for instance, have published lists of substances known to cause cancer, reproductive toxicity, or other harmful effects.

Control dust, mist and fumes at the source where possible. In this regard use good work practices and follow the recommendations of the manufacturers or suppliers, OSHA/NIOSH, and occupational and trade associations. Water should be used for dust suppression when wet cutting is feasible. When the hazards from inhalation of dust, mists and fumes cannot be eliminated, the operator and any bystanders should always wear a respirator approved by NIOSH/MSHA for the materials being used.

# JWN-SERIES — TABLE OF CONTENTS

## **MQ WHITEMAN — JWN-SERIES RIDE-ON POWER TROWEL**

Proposition 65 Warning .....	2
Silicosis/Respiratory Warnings .....	3
Table of Contents .....	4
Parts Ordering Procedures .....	5
Training Checklist .....	6
Daily Pre-Operation Checklist .....	7
Safety Message Alert Symbols .....	8-9
Rules For Safe Operation .....	10-13
Specifications (Trowel) .....	14
Specifications (Engine) .....	15
General Information .....	16
Controls and Indicators .....	17-18
Basic Engine .....	19
New Machine Setup Instructions .....	20
Initial Start-Up .....	21-23
Maintenance .....	24-35
Troubleshooting (Engine) .....	36-37
Troubleshooting (Trowel) .....	38-39
Explanation of Codes In Remarks Column .....	40
Suggested Spare Parts & Service Items .....	41
Nameplate and Decals .....	42-43
Pivot Assembly (Left/Right) .....	44-45
Steering Handles Assembly (Left/Right) .....	46-47
Steering Control Assembly (Left/Right) .....	48-49
Gearbox Assembly (Right) .....	50-51
Gearbox Assembly (Left) .....	52-53
Twin Pitch Handle Assembly (Left/Right) .....	54-55
Twin Pitch Tower Assembly (Left/Right) .....	56-57
Twin Pitch Miter Box Assembly (Left/Right) .....	58-59
Drive Assembly .....	60-61
Muffler/Belt Assembly .....	62-63
Beltguard Assembly .....	64-65
Spider Assembly (Right) .....	66-67
Spider Assembly (Left) .....	68-69

Yoke Assembly .....	70-71
Foot Pedals/Throttle Assembly .....	72-73
Control Panel Assembly .....	74-75
Frame/Fuel Assembly .....	76-77
Battery Assembly .....	78-79
Spray Assembly .....	80-81
Light Assembly .....	82-83
Seat Frame Assembly .....	84-85
EZ-Mover Assembly .....	86-87

## **HONDA GX-670-TAF ENGINE**

Air Cleaner Assembly .....	88-89
Camshaft Assembly .....	90-91
Carburetor Assembly .....	92-93
Control Assembly .....	94-95
Control Box Assembly .....	96-97
Crankcase Cover Assembly .....	98-99
Crankshaft Assembly .....	100-101
Cylinder Barrel Assembly .....	102-103
Cylinder Head Assembly .....	104-105
Fan Cover Assembly .....	106-107
Flywheel Assembly .....	108-109
Fuel Pump Assembly .....	110-111
Ignition Coil Assembly .....	112-113
Labels Assembly .....	114-115
Oil Cooler Assembly .....	116-117
Piston & Connecting Rod Assembly .....	118-119
Starter Motor Assembly .....	120-121

Terms And Conditions Of Sale .....	122
------------------------------------	-----

# PARTS ORDERING PROCEDURES

## Ordering parts has never been easier! Choose from three easy options:

Effective:  
January 1<sup>st</sup>, 2006

www.multiquip.com



### Order via Internet (Dealers Only):

Order parts on-line using Multiquip's SmartEquip website!

- View Parts Diagrams
- Order Parts
- Print Specification Information



If you have an MQ Account, to obtain a Username and Password, E-mail us at: [parts@multiquip.com](mailto:parts@multiquip.com).

To obtain an MQ Account, contact your District Sales Manager for more information.

Goto [www.multiquip.com](http://www.multiquip.com) and click on **Order Parts** to log in and save!

Use the **internet** and qualify for a **5% Discount** on *Standard orders* for all orders which include complete part numbers.\*

Note: Discounts Are Subject To Change



### Order via Fax (Dealers Only):

All customers are welcome to order parts via Fax.

**Domestic (US) Customers dial:**  
1-800-6-PARTS-7 (800-672-7877)

**Fax** your order in and qualify for a **2% Discount** on *Standard orders* for all orders which include complete part numbers.\*

Note: Discounts Are Subject To Change



**Order via Phone: Domestic (US) Dealers Call:**  
1-800-427-1244

### Non-Dealer Customers:

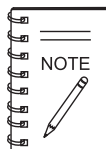
Contact your local Multiquip Dealer for parts or call 800-427-1244 for help in locating a dealer near you.



**International Customers** should contact their local Multiquip Representatives for Parts Ordering information.

## When ordering parts, please supply:

- |   |  |
|---|--|
| <input type="checkbox"/> Dealer Account Number                                | <input type="checkbox"/> Specify Preferred Method of Shipment:                         |
| <input type="checkbox"/> Dealer Name and Address                              | <input checked="" type="checkbox"/> UPS/Fed Ex <input checked="" type="checkbox"/> DHL |
| <input type="checkbox"/> Shipping Address (if different than billing address) | <input type="checkbox"/> Priority One <input checked="" type="checkbox"/> Truck        |
| <input type="checkbox"/> Return Fax Number                                    | <input type="checkbox"/> Ground  |
| <input type="checkbox"/> Applicable Model Number                              | <input type="checkbox"/> Next Day  |
| <input type="checkbox"/> Quantity, Part Number and Description of Each Part   | <input type="checkbox"/> Second/Third Day  |



All orders are treated as *Standard Orders* and will ship the same day if received prior to 3PM PST.

WE ACCEPT ALL MAJOR CREDIT CARDS!



# JWN-SERIES — TRAINING CHECKLIST

## TRAINING CHECKLIST

This checklist will lists some of the minimum requirements for machine maintenance and operation. Please feel free to detach it and make copies. Use this checklist whenever a new operator is to be trained or it can be used as a review for more experienced operators.

TRAINING CHECKLIST			
NO.	DESCRIPTION	OK?	DATE
1	Read Operator's Manual completely.		
2	Machine layout, location of components, checking of engine and hydraulic oil levels.		
3	Fuel system, refueling procedure.		
4	Operation of spray and lights (if equipped).		
5	Operation of controls (machine not running).		
6	Safety controls, seat "kill switch" operation.		
7	Emergency stop procedures.		
8	Startup of machine.		
9	Maintaining a hover.		
10	Maneuvering.		
11	Pitching.		
12	Matching blade pitch between towers Twin Pitch™, disengaging the linkage.		
13	Concrete finishing techniques.		
14	Shutdown of machine.		
15	Lifting of machine (lift loops).		
16	Machine transport and storage.		

Operator \_\_\_\_\_ Trainee \_\_\_\_\_

COMMENTS:

# JWN-SERIES — DAILY PRE-OPERATION CHECKLIST

## DAILY PRE-OPERATION CHECKLIST

DAILY PRE-OPERATION CHECKLIST		✓	✓	✓	✓	✓	✓
1	Engine Oil Level.						
2	Gearbox Fluid Level.						
3	Radiator Coolant Level.						
4	Condition of Blades.						
5	Blade Pitch Operation.						
6	Safety-Stop Switch Operation.						
7	Steering Control Operation.						
8	Condition of Belts.						

COMMENTS:

# JWN-SERIES — SAFETY MESSAGE ALERT SYMBOLS

## FOR YOUR SAFETY AND THE SAFETY OF OTHERS!

Safety precautions should be followed at all times when operating this equipment. Failure to read, understand and comply with the Safety Messages and Operating Instructions could result in injury to yourself and others.

This Operation Manual has been developed to provide instructions for the safe and efficient operation of the JWN - Series Ride-On Trowel. For engine maintenance information, please refer to the engine manufacturer's instructions for data relative to its safe operation.



**Before using this Ride-On Trowel, ensure that the operating individual has read, understands, and complies with all instructions in this manual.**

## SAFETY MESSAGE ALERT SYMBOLS

The three (3) Safety Messages shown below will inform you about potential hazards that could injure you or others. The Safety Messages specifically address the level of exposure to the operator, and are preceded by one of three words: **DANGER**, **WARNING**, or **CAUTION**.

### **DANGER**

You **WILL** be **KILLED** or **SERIOUSLY INJURED** if you **DO NOT** follow these directions.

### **WARNING**

You **CAN** be **KILLED** or **SERIOUSLY INJURED** if you **DO NOT** follow these directions.

### **CAUTION**

You **CAN** be **INJURED** if you **DO NOT** follow these directions.

Potential hazards associated with trowel operation will be referenced with Hazard Symbols which appear throughout this manual, and will be referenced in conjunction with Safety Message Alert Symbols.

## HAZARD SYMBOLS



### Lethal Exhaust Gases



Engine exhaust gases contain poisonous carbon monoxide. This gas is colorless and odorless, and can cause death if inhaled. **NEVER** operate this equipment in a confined area or enclosed structure that does not provide ample free flow air.



### Explosive Fuel



Gasoline is extremely flammable, and its vapors can cause an explosion if ignited. **DO NOT** start the engine near spilled fuel or combustible fluids. **DO NOT** fill the fuel tank while the engine is running or hot. **DO NOT** overfill tank, since spilled fuel could ignite if it comes into contact with hot engine parts or sparks from the ignition system. Store fuel in approved containers, in well-ventilated areas and away from sparks and flames. **NEVER** use fuel as a cleaning agent.



### Burn Hazards



Engine components can generate extreme heat. To prevent burns, **DO NOT** touch these areas while the engine is running or immediately after operations. **NEVER** operate the engine with heat shields or heat guards removed.



### Rotating Parts



**NEVER** operate equipment with covers, or guards removed. Keep **fingers, hands, hair** and **clothing** away from all moving parts to prevent injury.



# JWN-SERIES — SAFETY MESSAGE ALERT SYMBOLS



## Accidental Starting

Accidental starts can cause severe injury or death. **ALWAYS** place the ON/OFF switch in the OFF position. Disconnect and ground spark plug lead and disconnect negative battery cable from battery before servicing.



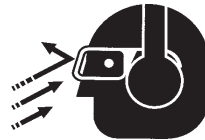
## Respiratory Hazard



**ALWAYS** wear approved respiratory protection.



## Sight and Hearing hazard



**ALWAYS** wear approved eye and hearing protection.



## Over Speed Conditions



**NEVER** tamper with the factory settings of the engine governor or settings. Personal injury and damage to the engine or equipment can result if operating in speed ranges above maximum allowable.



## Equipment Damage Messages

Other important messages are provided throughout this manual to help prevent damage to your trowel, other property, or the surrounding environment.



## CAUTION

This *Ride-On trowel*, other property, or the surrounding environment could be damaged if you do not follow instructions.

# JWN-SERIES — RULES FOR SAFE OPERATION

## RULES FOR SAFE OPERATION

### **WARNING**

Failure to follow instructions in this manual may lead to serious injury or even death! This equipment is to be operated by trained and qualified personnel only! This equipment is for industrial use only.

The following safety guidelines should always be used when operating the JWN-SERIES Ride-On Trowel.

### SAFETY

- **DO NOT** operate or service this equipment before you read, understand, and comply with all safety messages in this manual. The manual must be kept available and accessible to the operator.



- This equipment should not be operated by persons under the minimum statutory age limit.
- **NEVER** use this machine for any purpose other than those described in this manual.
- **NEVER** operate the trowel without proper protective clothing, shatterproof glasses, steel-toed boots and other protective devices required for the job.

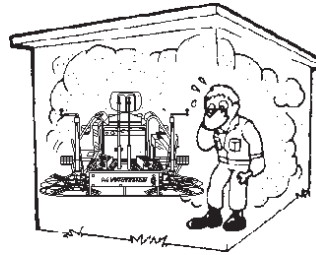


- **NEVER** use accessories or attachments which are not recommended by the manufacturer for this equipment. Damage to the equipment and/or injury to user may result.
- Manufacturer does not assume responsibility for any accident due to equipment modifications. Unauthorized equipment modification will void all warranties. Any modification which could lead to a change in the original characteristics of the machine should be made only by the manufacturer who shall confirm that the machine is in conformity with appropriate safety regulations.

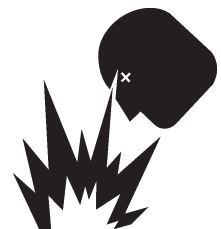
- **NEVER** operate this equipment when not feeling well due to fatigue, illness or taking medicine.
- **NEVER** operate the trowel under the influence of drugs or alcohol.
- Replace nameplate, operation and safety decals when they become difficult to read.
- **ALWAYS** check the trowel for loosened hardware such as nuts and bolts before starting.
- **NEVER** touch the hot exhaust manifold, muffler or cylinder. Allow these parts to cool before servicing the trowel. Contact with **hot!** components can cause serious burns.



- The engine of this trowel requires an adequate free flow of cooling air. **NEVER** operate the trowel in any enclosed or narrow area where free flow of the air is restricted. If the air flow is restricted it will cause serious damage to the engine and may cause injury to people. Remember the engine gives off **DEADLY** carbon monoxide gas.



- **ALWAYS** refuel in a well-ventilated area, away from sparks and open flames.
- Topping-off to filler port is dangerous, as it tends to spill fuel.
- **NEVER** use fuel as a cleaning agent.
- **ALWAYS** use extreme caution when working with **flammable** liquids. When refueling, **STOP** the engine. Allow the engine to cool before adding fuel or performing service and maintenance functions.
- **NEVER** operate the trowel in an explosive atmosphere where fumes are present, or near combustible materials. An explosion or fire could result in severe **bodily harm or even death**.
- **NEVER** **smoke** around or near the machine. Fire or explosion could result from **fuel vapors**, or if fuel is spilled on a **hot!** engine.



# JWN-SERIES — RULES FOR SAFE OPERATION

- **NEVER** run engine without air filter. Severe engine damage may occur. Service air filter frequently to prevent carburetor malfunction.
- **NEVER** place your **feet** or **hands** inside the guard rings while starting or operating this equipment.
- **AVOID** wearing jewelry or loose fitting clothing that may snag on the controls or moving parts as this can cause a serious injury.
- **ALWAYS** keep clear of **rotating** or **moving parts** while operating the trowel.
- **Moving Parts** – Shut down the engine before performing service or maintenance functions. Contact with moving parts can cause serious injury.
- **ALWAYS** check to make sure that the operating area is clear before starting the engine.
- **NEVER** leave the machine **unattended** while running.
- **ALWAYS** be sure the operator is familiar with proper safety precautions and operations techniques before using trowel.
- **ALWAYS** keep the work area well organized.
- **ALWAYS** clear the work area of any debris, tools, etc. that would constitute a hazard while the trowel is in operation.

## **WARNING**

**ALWAYS** check to make sure that the operating area is clear before starting the engine.

- No one other than the operator is to be in the working area when the trowel is in operation.
- **NEVER** allow passengers or riders on the trowel during operation.
- Always observe all applicable compulsory regulations relevant to environmental protection, especially, fuel storage, the handling of hazardous substances, and the wearing of protective clothing and equipment. Instruct the user as necessary, or, as the user, request this information and training.
- **ALWAYS** store equipment properly when it is not being used. Equipment should be stored in a clean, dry location out of the reach of children.

## **DANGER**

Pay close attention to ventilation when operating the trowel in confined spaces such as tunnels, buildings or similar areas. The engine exhaust contains harmful elements. Ensure proper air flow to move engine exhaust away from the operator.



## Lifting the Ride-On Trowel

## **CAUTION**

This ride-on trowel is very **heavy** and awkward to move around. Use proper heavy lifting procedures and **DO NOT** attempt to lift the ride-on trowel by the guard rings.

The JWN-SERIES Ride-On Power Trowel is designed to be moved and handled several ways.

The easiest way to lift the trowel is to utilize the lift loops that are welded to the frame. These lift loops are located to the left and right sides of the operator's seat.

A strap or chain can be attached to these lift loops, allowing a forklift or crane to lift the trowel up onto and off of a slab of concrete. The strap or chain should have a minimum 2,000 pounds (1000-kg) lifting capacity and the lifting gear must be capable of lifting at least this amount.

## **DANGER**

**NEVER** stand under or allow anyone else to stand under the trowel while it is being lifted.



# JWN-SERIES — RULES FOR SAFE OPERATION

## Transporting

- **ALWAYS** shutdown engine before transporting.
- Tighten fuel tank cap securely and close fuel petcock to prevent fuel from spilling.
- Drain fuel when transporting trowel for long distances or over bad roads.
- When placing the trowel on a truck-bed for transport, **always** tie-down the trowel.
- If the trowel is being transported via a trailer, make sure the trailer complies with all local and state safety transportation laws. Refer to the following "**Towing Safety Precautions**" for basic towing techniques.

## Towing Safety Precautions

### CAUTION

Conform to **Department of Transportation (DOT) Safety Towing Regulations** before transporting trowel on public roads.

To reduce the possibility of an accident while transporting the trowel on public roads, always make sure the trailer that supports the trowel and the towing vehicle are in good operating condition and both units are mechanically sound.

The following list of suggestions should be used when towing your trowel:

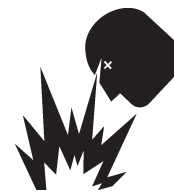
- Make sure the hitch and coupling of the towing vehicle are rated equal to, or greater than the trailer "gross vehicle weight rating" (GVWR) of 6,000 lbs.
- **ALWAYS** inspect the hitch and coupling for wear. **NEVER** tow a trailer with defective hitches, couplings, chains, etc.
- Check the tire air pressure on both towing vehicle and trailer. **Trailer tires should be inflated to 50 psi cold.** Also check the tire tread wear on both vehicles.
- **ALWAYS** make sure the trailer is equipped with "**Safety Chains**".
- **ALWAYS** attach trailer's safety chains to towing vehicle properly.
- **ALWAYS** make sure the vehicle and trailer directional, backup, brake, and trailer lights are connected and working
- **DO NOT** exceed the recommended highway speed when towing. Unless posted otherwise, do not exceed 45 MPH highway, and 10 MPH off-road.

- Use chock-blocks at each wheel when parked to prevent trailer from rolling.
- Use the trailer's swivel jack to adjust the trailer height to a level position while parked.
- Avoid sudden stops and starts. This can cause the trailer to skid or jack-knife. Smooth, gradual starts and stops will improve towing.
- Avoid sharp turns.
- Trailer should be adjusted to a level position at all times when towing.
- Raise and lock trailer wheel stand in the "**UP**" position when transporting.
- DOT requirements include the following:
  - Connect and test electric brake operation.
  - Secure portable power cables in cable tray with tie wraps.

## Battery

The battery contains acids that can cause injury to the eyes and skin. To avoid eye irritation, **always** wear safety glasses or face shielding. Use well insulated gloves when picking the battery up. Use the following guidelines when handling the battery.

- **DO NOT** drop the battery. Any impact to the battery may cause it to explode.
- **DO NOT** expose the battery to open flames, sparks, lit cigarettes etc. The battery contains combustible gases and liquids. If these gases and liquids come in contact with a flame or spark an explosion can occur.
- **ALWAYS** keep the battery charged. If the battery is not charged a buildup of combustible gas will occur.
- **ALWAYS** keep battery cables in good working condition. Repair or replace all worn cables.
- **ALWAYS** disconnect the **negative battery terminal** before performing service on the trowel.
- **ALWAYS** recharge the battery in a vented air environment to avoid risk of a dangerous concentration of combustible gases.
- In case the battery liquid, (dilute sulfuric acid), comes in contact with **clothing or skin**, rinse skin or clothing immediately with plenty of water.
- In case the battery liquid, (dilute sulfuric acid), comes in contact with your **eyes**, rinse eyes immediately with plenty of water, then contact the nearest doctor or hospital and seek medical attention.



# JWN-SERIES — RULES FOR SAFE OPERATION

## Maintenance Safety

- **ALWAYS** shut down the engine and disconnect battery before performing service or maintenance functions. Contact with moving parts can cause serious injury.
- Securely support any trowel components that must be raised.
- **NEVER** lubricate components or attempt service on a running trowel.
- **ALWAYS** allow the trowel a proper amount of time to cool before servicing.
- Keep the trowel in proper running condition.
- Make sure that there is no buildup of concrete, grease, oil or debris on the machine.
- Repair damage to the trowel immediately and always replace broken parts.
- Dispose of hazardous waste properly. Examples of potentially hazardous waste are used motor oil, fuel and fuel filters.
- **DO NOT** use plastic food containers to dispose of hazardous waste.
- **DO NOT** pour waste oil or fuel directly onto the ground, down a drain or into any water source.
- **NEVER** store trowel with fuel in the tank for any extended period of time. Always clean up spilled fuel immediately.

## Emergencies

- **ALWAYS** know the location of the nearest **fire extinguisher**.



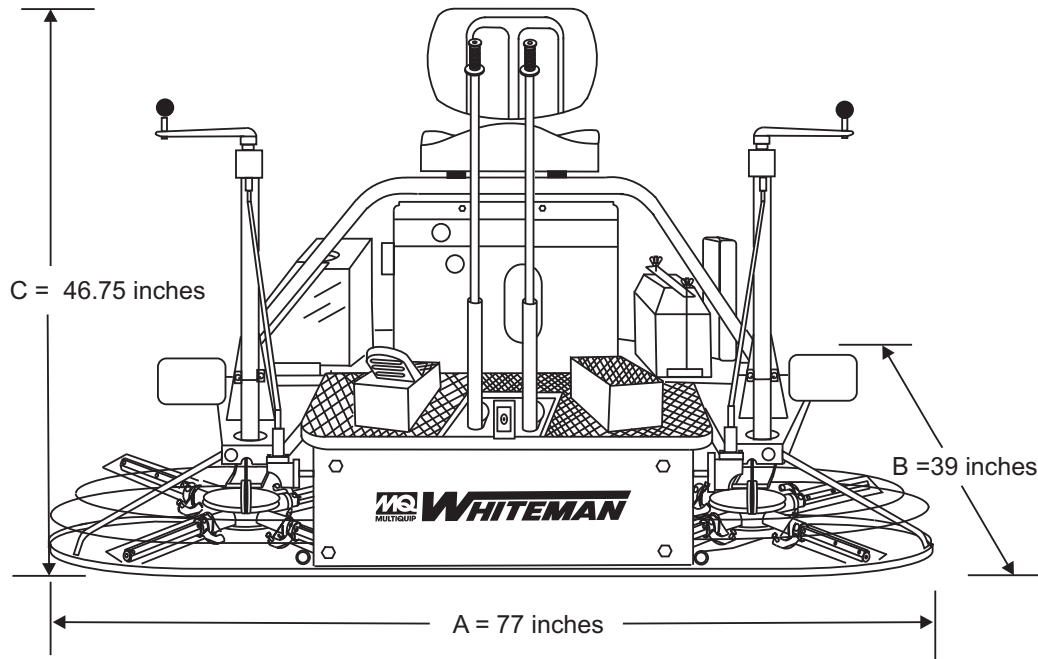
- **ALWAYS** know the location of the nearest **first aid kit**.



- Know the phone numbers of the nearest **ambulance, doctor** and **fire department**. Ensure that a phone or radio is readily available at the jobsite. If this is not possible, know the location of the nearest phone. This information will be invaluable in the event of an emergency.



# JWN-SERIES— SPECIFICATIONS (TROWEL)



**Figure 1. JWN-Series Dimensions Specifications**

**Table 2. JWN Series Specifications**

A—Length – in. (cm)	77.0 (195.6)
B—Width – in. (cm)	39 (99)
C—Height – in. (cm) <sup>1</sup>	46.75 (118.7)
Weight – lbs. (kgs.) Operating	685 (311.3)
Weight – lbs. (kgs.) Shipping	885 (402.27)
Sound Pressure – dBA <sup>2</sup>	TBD
Vibration – ft/s <sup>2</sup> (m/ s <sup>2</sup> ) <sup>3</sup>	TBD
Engine – H.P.	24 (HONDA)
Fuel Tank – gallons (liters)	5 (19.23)
Rotor – RPM (Dry Concrete)	180 Min
Path Width – in. (cm)	75 (191)
Engine Oil Capacity (w/new filter)	2 Quarts (1.9 Liters)
Gear Box Oil Capacity	69 oz. Mobil SCH 634 Iso VG640
Fuel Consumption (full load)	1.71 gallons/hour
Radiator capacity	TBD

**NOTE:**

1. Sound pressure is "A" weighted . Measured at the operators ear position while the ride-on trowel is operating at full throttle on concrete in a manner most often experienced in "**normal**" circumstances. Sound pressure may vary depending upon the condition of the concrete. Hearing protection is always recommended.

2. The vibration level indicated is the maximum RMS (Root Mean Square) value obtained at the handle grip while operating the ride-on trowel on curing concrete in a manner most often experienced in "**normal**" circumstances. Values were obtained from all three axes of motion. The values shown represent the maximum RMS value from these measurements.

# JWN-SERIES— SPECIFICATIONS (ENGINE)

**Table 3. JWN Series Engine Specifications**

<b>Model</b>	<b>Honda GX-670-TAF Engine</b>
Type	4 Stroke, Overhead Valve, 90 degree V -Twin 2 cylinder gasoline engine.
Piston Displacement	40.9 cu.in. (670 cc)
Max. Output	24 bhp/3,600 rpm (17.6 KW)
Max. Torque	31.8 lbf-ft at 2,500 rpm
Cooling System	Forced Air
Engine Oil Capacity	1.69 qt. (1.60 liters) 2.01 qt. (1.90 liters w/oil filter replacement)
Fuel	Unleaded gasoline Octane rating of 86 or higher
Fuel Consumption	1.71 gph
Starting System	Electric Start/Transistorized Magneto
Spark Plug Type	NGK: ZGR5A DENSO: J16CR-U
Spark Plug Gap	0.028-0.031 in. (0.70 - 0.80 mm)
Length	16.2 in. (41.2 cm)
Height	18.5 in. (47.1 cm)
Width	18.0 in. (45.7 cm)
Weight (dry)	94.8 lbs (43.0 kg)

## JWN Series Ride-On PowerTrowel Familiarization

The JWN Series Ride-On Power Trowel is designed for the floating and finishing of concrete slabs.

Take a walk around your trowel. Take notice of all the major components (see Figures 2 and 3, pages 16 and 17) like the engine, blades, air cleaner, fuel system, fuel shut-off valve, ignition switch etc. Check that there is always oil in the engine, and gear oil in the gearbox assembly.

Read all the safety instructions carefully. Safety instructions will be found throughout this manual and on the machine. Keep all safety information in good, readable condition. Operators should be well trained on the operation and maintenance of the trowel.

Look at the operator control levers. Grab the control levers and move them around a bit. Look to see how moving the control levers causes the gearboxes and frame to move.

Notice the foot pedal which controls the engine speed. Also take a look at the main driveline of the trowel. Take note and reference how the belts look, this is the way the belts should look when adjusted properly.

Before using your trowel, test it on a flat watered down section of finished concrete. This trial test run will increase your confidence in using the trowel and at the same time it will familiarize you with the trowel's controls and indicators. In addition you will understand how the trowel will handle under actual conditions.

## Engine

This trowel is equipped with an air cooled 24 HP Honda gasoline engine. Refer to the engine owner's manual for specific instructions regarding engine operation. This manual is included with the trowel at the time of shipping. Please contact your nearest Multiquip Dealer for a replacement should the original manual disappear.

## Blades

The blades of the trowel finish the concrete as they are swirled around the surface. Blades are classified as combination (10 or 8 inches wide) and finish (6 inches wide). This trowel is equipped with four blades per rotor equally spaced in a radial pattern and attached to a vertical rotating shaft by means of a **spider assembly**.

Figures 2 and 3 show the location of the controls, indicators and general maintenance parts. Each control may perform more than one function. The functions of each control or indicator is on pages 16 and 17.

## Gearboxes

The JWN Series Ride-On Power Trowel uses two separate gearbox assemblies that are enclosed in rugged cast aluminum gear cases.

The gearbox casing has a large oil capacity allowing optimum lubrication to critical points.

## Steering Assist

Dual control levers located in front of the operator's seat are provided for steering the trowel. The control levers are linked to two spring loaded cylinders.

Push the left control lever forward and pull the right control lever backward and the trowel will rotate clockwise on approximately a center axis. Pull the left control lever backward and push the right control lever forward and the trowel will rotate counterclockwise. See Table 5 on page 22 for a complete description on the control levers directional positioning.

## Constant Velocity Joints (CV-Joints)

Constant velocity joints insure the efficient transfer of power to the drive shaft and maintain the timing of the gearboxes without any chance of slippage.

## Training

For training, please use the "TRAINING CHECKLIST" located in the front of this manual (Page 5). This checklist is not intended to be a substitute for proper training but will provide an outline for an experienced operator to provide training to a new operator.



## JWN-SERIES — CONTROLS AND INDICATORS

1. **Seat** – Engine will not start unless operator is seated.
2. **Steering Control Levers** -Directs the unit forward, reverse, left, or right.
3. **Retardant Spray Control Button** – Sprays retardant through the nozzle at the front of the machine.
4. **Twin Pitch Control** – Both pitch towers are linked together. One crank may be turned to adjust the blade pitch simultaneously or individually controlled for each set of blades. Turn the crank as marked on its top surface to increase or decrease blade pitch.
5. **Light Switch** – Turns on three halogen lights. Two in front one in rear.
6. **Ignition Switch** – With key inserted, turn clockwise to start engine.
7. **Hour Meter** - Indicates number of hours the engine is run.
8. **Choke Control Lever** - In cold weather pull this lever to start engine. After engine warms push knob all the way in.
9. **Fuel Gauge/Filler Cap** - Indicates the amount of fuel in the fuel tank. Remove this cap to add fuel.
10. **Fuel Tank** - Holds 5 gallons of unleaded gasoline.
11. **Left Foot Riser** – Operator foot rest pedal.
12. **Spray Nozzle** – Spray nozzle for retardant.
13. **Right Foot Pedal** – Controls blade speed. Slow blade speed is accomplished by slightly depressing the foot pedal. Maximum blade speed is accomplished by fully depressing the foot pedal.
14. **EZ- Mover Boss** – Front attachment point for EZ Mover. Used to move the trowel.
15. **Dip Stick**- Access hole provided to check engine oil.
16. **Spark Plug**- Access the spark plug through this cutout.

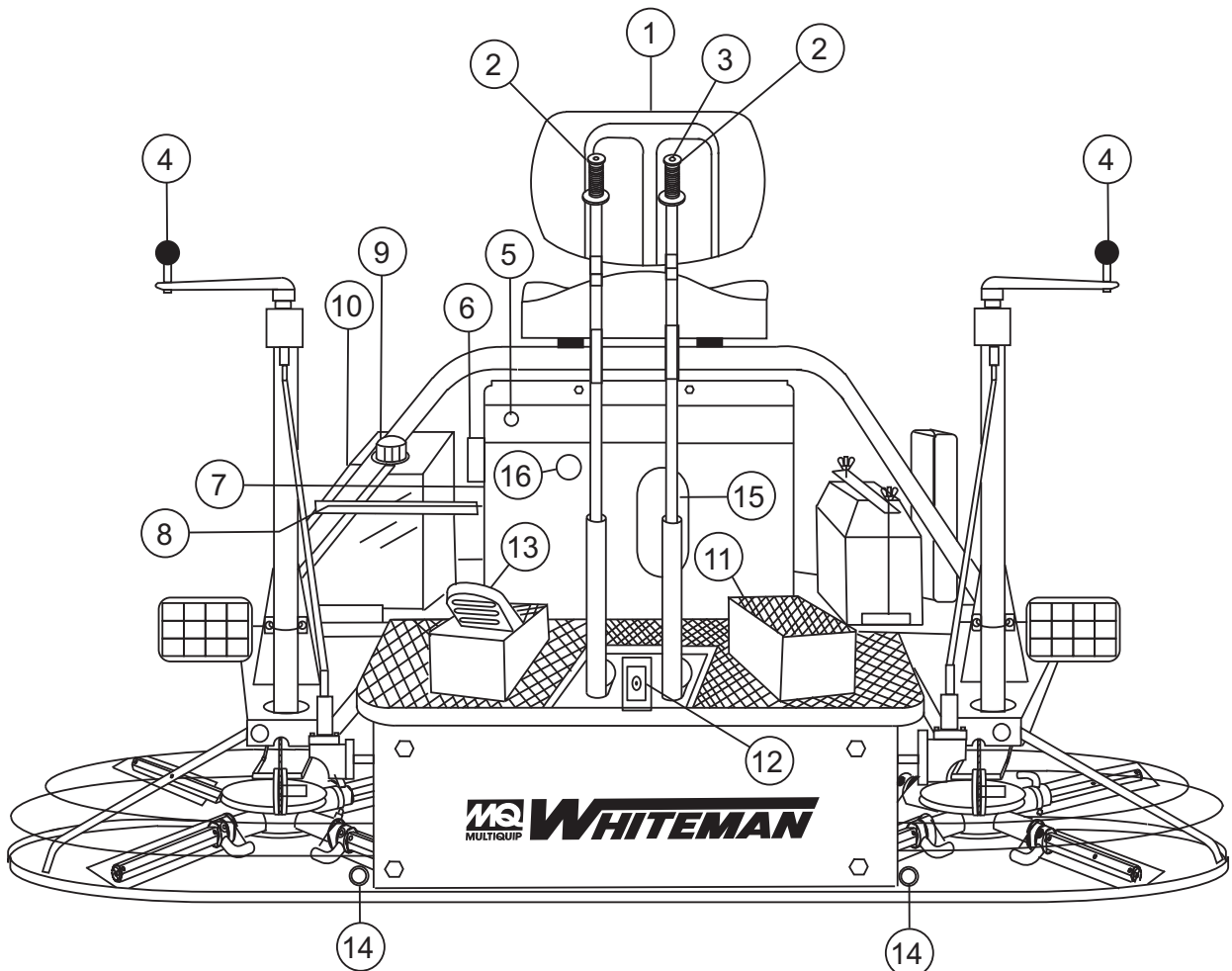
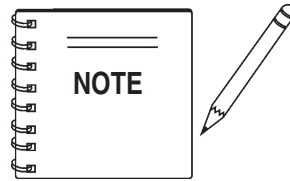


Figure 2. JWN-SERIES Controls and Indicators (Front)

# JWN-SERIES — CONTROLS AND INDICATORS

17. **Safety "kill switch"** – Shuts down engine when seat is empty.
18. **Rear Light** – The JWN-Series Ride-On Power Trowel has three 12 volt halogen lights.
19. **Lift Loops** – Located on both sides of the main frame. Used to lift the trowel.
20. **Engine Air Filter** – Protects the engine from dirt.
21. **Oil Filter** – Filters the engine oil.
22. **Oil Drain** - Remove the plug to drain the engine oil.
23. **Retardant Spray Tank** – Holds 5 gallons of retardant.
24. **Retardant Spray Pump** – Delivers retardant to the spray nozzle.
25. **EZ- Mover Boss** – Rear attachment point for EZ Mover. Used to transport the trowel.
26. **Spiders (Left/Right)** – Consists of trowel arms, blades, wear plate, and thrust collar.
27. **Document Box**- Contains all product documentation.
28. **Battery** – Provides +12V DC power to the electrical system.
29. **Belt Guard** – Encloses drive belt used in conjunction with clutch.
30. **Engine Oil Fill** - Remove this cap to add engine oil.



Read this entire instruction manual completely before attempting to operate the trowel.

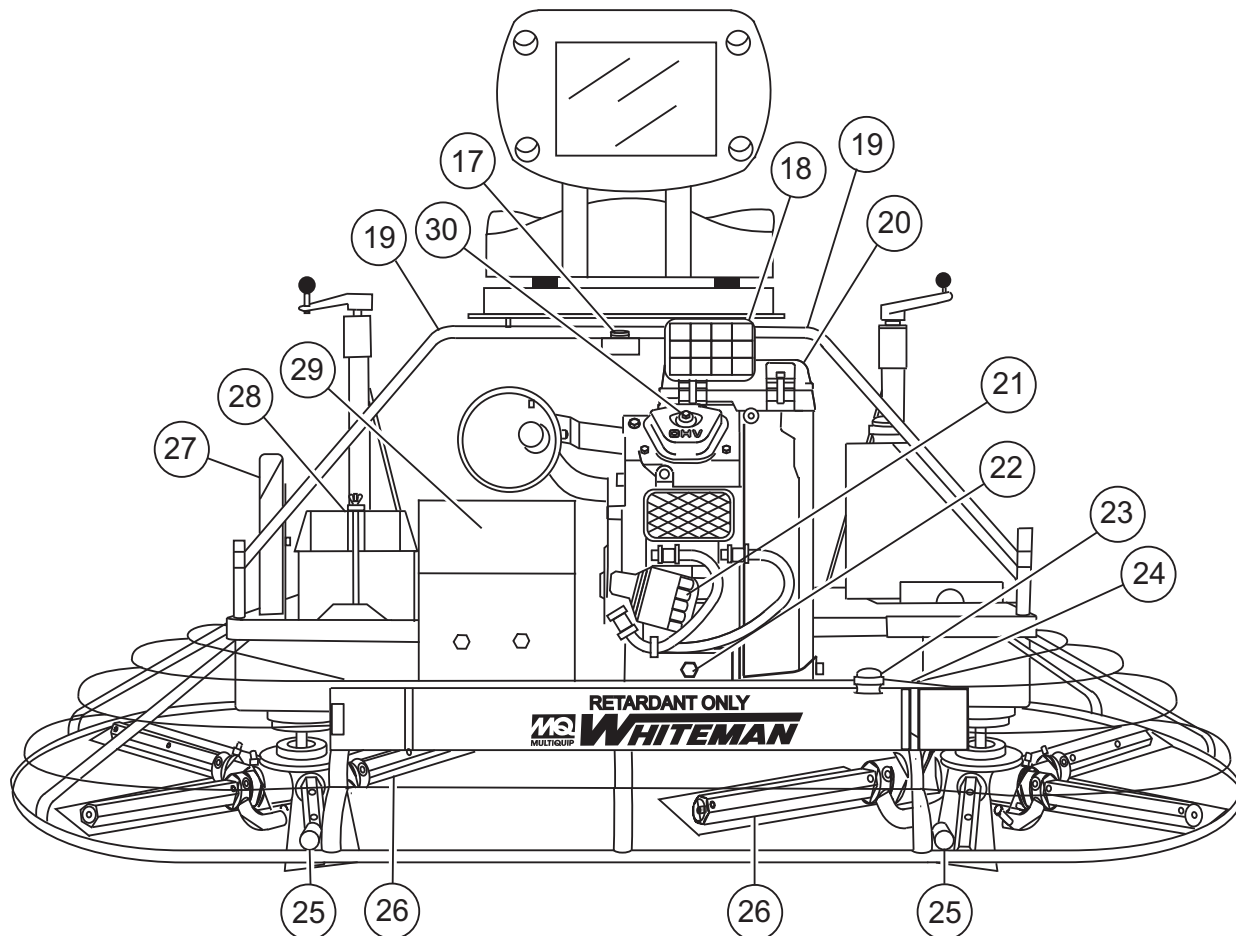


Figure 3. JWN-SERIES Controls and Indicators (Rear)

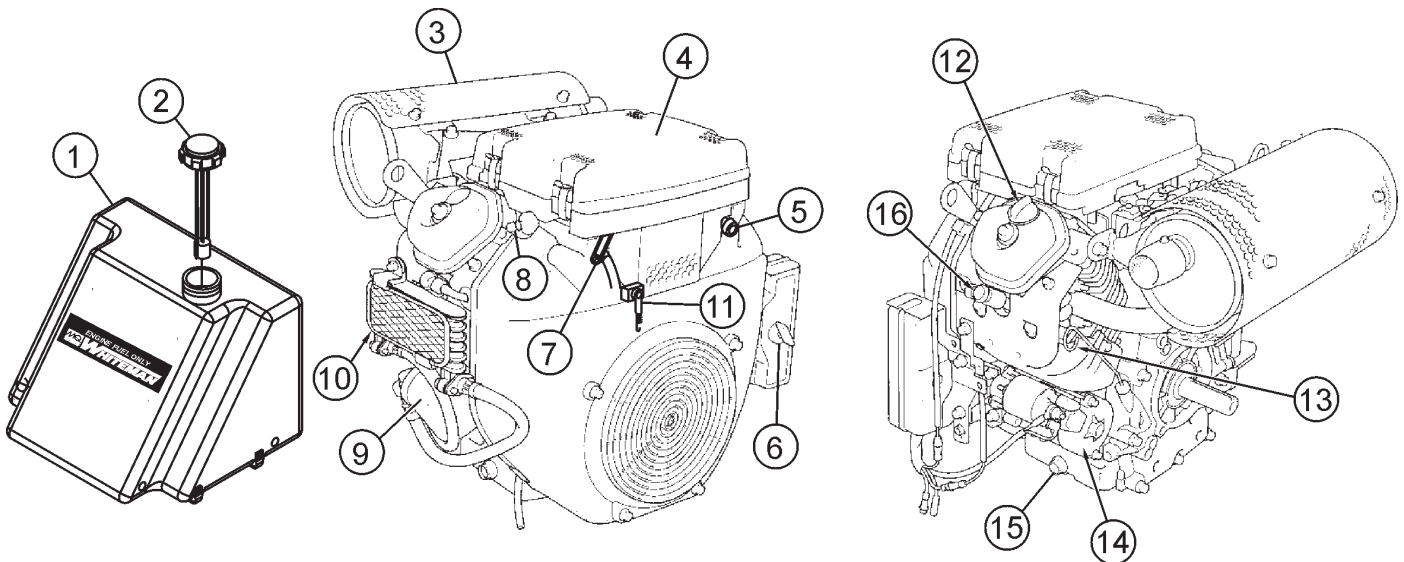


Figure 4. Engine Controls and Components

## INITIAL SERVICING

The engine (Figure 4) must be checked for proper lubrication and filled with fuel prior to operation. Refer to the manufacturer's engine manual for instructions & details of operation and servicing. The engine shown above is a **HONDA** engine. Operation for other types of engines may vary somewhat.

1. **Fuel Tank** – Five gallon capacity; use unleaded gasoline.
2. **Fuel Filler Cap** – Remove this cap to add unleaded gasoline to the fuel tank. Make sure cap is tightened securely. **DO NOT** over fill.



**DANGER**

Add fuel to the tank only when the engine is stopped and has had an opportunity to cool down. In the event of a fuel spill, **DO NOT** attempt to start the engine until the fuel residue has been completely wiped up and the area surrounding the engine is dry.

3. **Muffler** – Used to reduce noise and emissions.



**WARNING**

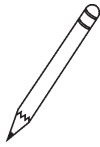
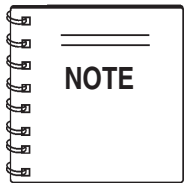
Engine components can generate extreme heat. To prevent burns, **DO NOT** touch these areas while the engine is running or immediately after operating. **NEVER** operate the engine with the muffler removed.

4. **Air Filter** – Prevents dirt and other debris from entering the fuel system. Unsnap air filter cover to gain access to filter element.
5. **Choke Knob** – Used in the starting of a cold engine or in cold weather conditions. The choke enriches the fuel mixture.
6. **Engine ON/OFF Switch** – "ON" position permits engine starting, "OFF" position stops engine operations.
7. **Fuel Drain Valve** – **OPEN** to let fuel flow, **CLOSE** to stop the flow of fuel.
8. **Fuel Filter** – Filters fuel for contaminants.
9. **Oil Filter** – Spin-on type, filters oil for contaminants.
10. **Oil Cooler** – Helps keep engine oil cooler for longer engine life.
11. **Throttle Lever** – Controlled by accelerator pedal, increases or decreases engine RPM.
12. **Oil Filler Cap** – Remove to add engine oil.
13. **Oil Dip Stick** – Remove to check amount and condition of oil in crankcase.
14. **Starter** – Starts engine when ignition key is rotated to the "ON" position.
15. **Oil Drain Plug** – Remove to drain crankcase oil.
16. **Spark Plug** – Provides spark to the ignition system. Set spark plug gap to 0.6 - 0.7 mm (0.028 - 0.031 inch) Clean spark plug once a week.

# JWN-SERIES — NEW MACHINE SETUP INSTRUCTIONS

## Trowel Pre-Set Up Instructions

The purpose of this section is to assist the user in setting up a **NEW** trowel. If your trowel is already assembled, (seat, handles, knobs and battery), this section can be skipped.



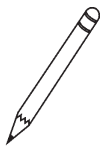
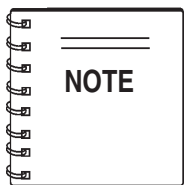
The new trowel cannot be put into service until the pre-setup installation instructions are completed. These pre-setup instructions only need to be performed at the time of unpacking a **NEW** trowel.

Before packaging and shipping, this JWN SERIES Ride-On Power Trowel was run and tested at the factory. If there are problems, please let us know.

## Control Handle Assembly

The steering control handles are not attached to the trowel's two lower handles at the time of shipment. To attach the steering control handles to the two lower handle assemblies perform the following:

1. Remove the bolts from the plastic bag tied to the control towers.
2. Remove all protective wrapping and straps from the control handles.
3. Slip the top (loose) piece into the base of the corresponding handle, making sure to line up the holes.
4. Install the bolt through the lined up holes and tighten the acorn nut onto the threaded end.

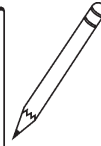
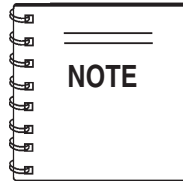


Some models are equipped with adjustable height handles. Adjust the height by placing the bolt through the set of holes that corresponds to the most comfortable height.

5. Pay close attention to any wires that may be inside the control handles. **DO NOT** pinch or cut any wires during installation.
6. Inside the plastic bag of parts are two knobs for the pitch control tower cranks. Install these two knobs onto the tower crank levers.

## Seat Assembly

The seat is not installed on the trowel for shipping purposes. To attach the seat perform the following:



There are two types of seats, depending on what type of trowel you have. J and B series trowels have slots on the seat mounting plate that allow **fore** and **aft** adjustment of the

seat. H and S-series trowels have a seat that is mounted on tracks, similar to an automobile seat. This seat can be adjusted **fore** and **aft** via the control lever under the front of the seat.

1. Remove the seat from the protective wrapping.
2. Remove the bolts on the bottom of the seat, and place seat on the seat mounting plate, then insert the bolts through the holes or slots on the seat mounting plate and tighten.

## Battery Setup

This trowel was shipped with a wet charged battery. This battery may need to be charged for a brief period of time as per the manufacturer instructions.

### CAUTION

Use all safety precautions specified by the battery manufacturer when working with the battery. See further specific safety information on page 14 of this manual.

To install the battery on the trowel, make sure that the battery is well seated in the battery box. Connect the positive cable to the positive terminal on the battery first, then connect the negative cable to the negative terminal. Close the plastic battery box cover and secure the battery box.

The following section is intended as a basic guide to the ride-on trowel operation, and is not to be considered a complete guide to concrete finishing. It is strongly suggested that all operators (experienced and novice) read “*Slabs on Grade*” published by the American Concrete Institute, Detroit Michigan.

**DO NOT** use your ride-on power trowel until this section is thoroughly understood.

## CAUTION

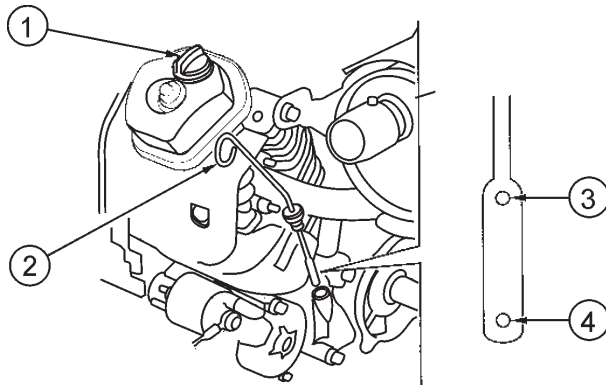
Failure to understand the operation of the JWN-SERIES trowel could result in severe damage to the machine or personal injury.

See Figures 2 and 3 (Pages 20 and 21) for the location of any control or indicator referenced in this manual.

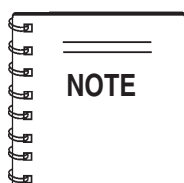
### Engine Oil Level

**ALWAYS** check engine oil **BEFORE EACH USE**.

1. Pull the engine oil dipstick (Item 2, Figure 5) from its holder.
2. Determine if engine oil is low (Figure 5).
3. If engine oil is low, remove oil filler cap (Item 1, Figure 5), and add correct amount of engine oil to bring oil level to a normal safe level. Use oil as recommended in Table 3.



**Figure 5. Engine Oil Dipstick**



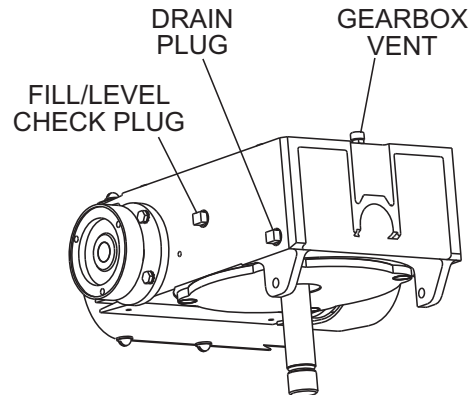
To prevent extensive engine wear or damage, always maintain the proper oil level in the crankcase. Never operate the engine with the oil level outside of marks on dipstick, (Items 3 and 4 in Figure 5.)

**Table 4. Recommended Viscosity Grades**

		10W-30, 10W-40							
		5W-20, 5W-30							
°F	-20	0	20	32	40	60	80	100	
°C	-30	-20	-10	0	10	20	30	40	
TEMPERATURE RANGE EXPECTED BEFORE NEXT OIL CHANGE									

### Gearbox Oil Level

1. Check the gearbox oil level in both gearboxes by removing the level plug and ensuring that the oil is at the correct level. See Figure 6.
2. Fill the gear box just to the level of the fill plug. (Figure 6) with 69 oz. of Mobil ISO VG 640 SCH 634 oil.



**Figure 6. Gearbox Oil Plugs/Sight Glass**

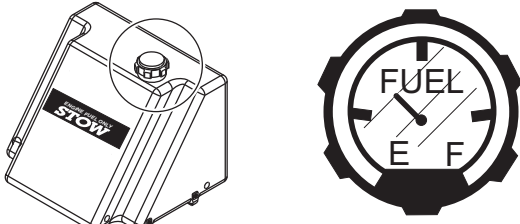
### Fuel

Determine if the engine fuel is low (Figure 7). If fuel level is low, remove the fuel filler cap and fill with unleaded gasoline.

## DANGER

Handle fuel safely. Motor fuels are highly flammable and can be dangerous if mishandled. **DO NOT** smoke while refueling. **DO NOT** attempt to refuel the ride-on trowel if the engine is hot or running. **DO NOT** attempt to start the engine until the fuel residue has been completely wiped up and the area surrounding the engine is dry.





**Figure 7. Fuel Gauge**

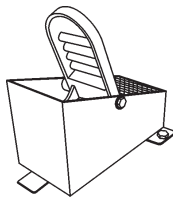
## Important Information Before You Start

1. This *ride-on trowel* is equipped with a safety "**safety stop switch**". This switch is located beneath the seat assembly. Remember the engine will not start unless an operator is sitting in the operator's seat. The weight of an operator depresses an electrical switch which will allow the engine to start.

## **! WARNING**

**NEVER** disable or disconnect the "safety stop switch". It is provided for the **operator's safety** and injury or death may result if it is disabled, disconnected or improperly maintained.

2. The safety stop switch should be used to stop the engine after every use. Doing this will verify the switch is working properly thus providing safety for the operator. Remember to turn the key to the "**OFF**" position after stopping the machine. Not doing so will drain the battery.
3. The right foot pedal (Figure 8) controls blade and engine speed. The position of the foot pedal determines the blade speed. Slow blade speed is obtained by slightly depressing the pedal. Maximum blade speed is obtained by fully depressing the pedal.

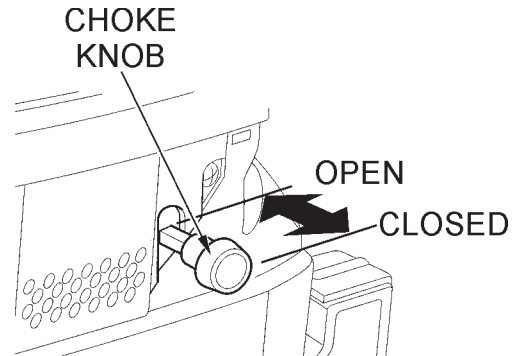


**Figure 8. Blade Speed Control Foot Pedal**

## Starting the Engine

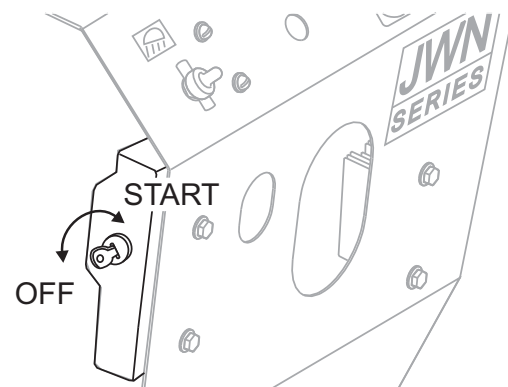
1. With one foot on the ground and the other foot placed on the trowel's platform, grab the frame near the seat and lift yourself onto the trowel. Sit in the operator's seat and ensure the control handles, foot pedal and control panel items can be comfortably accessed.

5. When starting a cold engine, pull the choke knob, (Figure 9) out to the **closed** position. In warm weather or when the engine is warm, the unit can be started with choke halfway or completely **open**.



**Figure 9. Choke Knob**

6. Keep your foot **OFF** the blade speed control pedal and in all circumstances, start the engine at idle (without touching the pedal).
7. Insert the **ignition key** into the ignition switch.
8. Turn the ignition key (Figure 10) clockwise and listen for the engine to start. Once the engine starts release ignition key.
9. If the engine fails to start in this manner, consult the engine owner's manual supplied with the trowel.
10. Test the safety stop switch by standing up briefly. The switch under the seat should cause the engine to stop. If the switch fails to shut down the engine. Turn off the engine with the key switch and repair the safety stop switch. See Table 6 (Troubleshooting ) for possible causes.

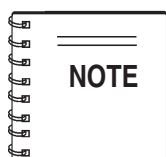


**Figure 10. Ignition Key**

11. Let the engine idle for 3-5 minutes. If choke is applied, push the choke to the open position as soon as the engine will run smoothly.

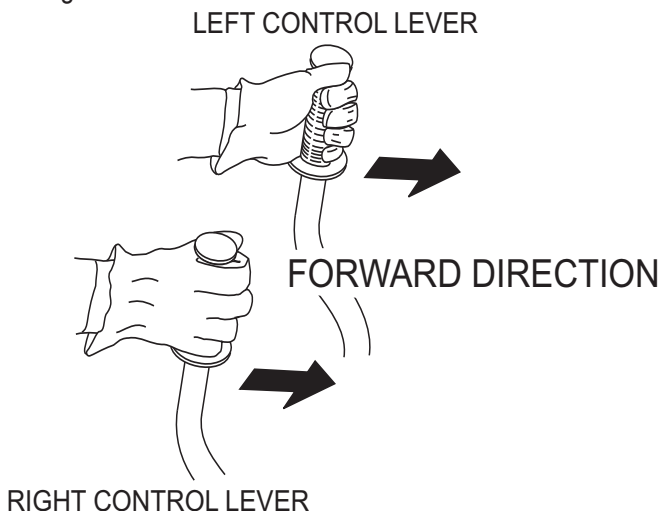
## Steering

Two control levers located in front of the operator's seat provide directional control for the JWN-SERIES Ride-On Power Trowel. Table 4 illustrates the various directional positions of the joysticks and their effect on the ride-on trowel.



All directional references with respect to the steering control levers are from the **operator's** seat position.

1. Push both the left and right control levers forward. See Figure 11.



**Figure 11. Left and Right Control Levers**

2. With your right foot quickly depress the right foot pedal halfway. Notice that the ride-on power trowel begins to move in a forward direction. Return both joystick controls to their neutral position to stop forward movement, then remove your right foot from the right foot pedal.
3. Practice holding the machine in one place as you increase blade speed. When about 75% of maximum blade speed has been reached, the blades will be moving at proper finishing speed. The machine may be difficult to keep in one place. Trying to keep the ride-on trowel stationary is a good practice for operation.
4. Practice maneuvering the ride-on trowel using the information listed in Table 4. Try to practice controlled motions as if you were finishing a slab of concrete. Practice edging and covering a large area.

5. Try adjusting the pitch of the blades. This can be done with the ride-on trowel stopped or while the trowel is moving, whatever feels comfortable. Test the operation of optional equipment like retardant spray and lights if equipped.
6. Pull both the left and right joysticks backward and repeat steps 3 through 6 while substituting the word reverse for forward.

**Table 4. Control Lever Directional Positioning**

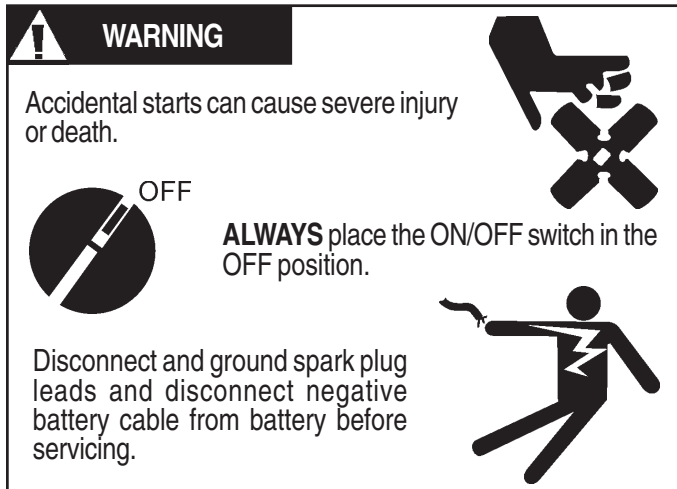
CONTROL LEVER & DIRECTION	RESULT
Move <b>LEFT</b> Control Lever <b>FORWARD</b> ↑	Causes only the left side of the ride-on trowel to move forward.
Move <b>LEFT</b> Control Lever <b>BACKWARD</b> ↓	Causes only the left side of the ride-on trowel to move backward.
Move <b>RIGHT</b> Control Lever <b>FORWARD</b> ↑	Causes only the right side of the ride-on trowel to move forward.
Move <b>RIGHT</b> Control Lever <b>BACKWARD</b> ↓	Causes only the right side of the ride-on trowel to move backward.
Move <b>BOTH</b> Control Levers <b>FORWARD</b> ↑ ↑	Causes the ride-on trowel to move forward in a straight line.
Move <b>BOTH</b> Control Levers <b>BACKWARD</b> ↓ ↓	Causes the ride-on trowel to move backward in a straight line.
Move <b>BOTH</b> Control Levers to the <b>RIGHT</b> → →	Causes the ride-on trowel to move to the right.
Move <b>BOTH</b> Control Levers to the <b>LEFT</b> ← ←	Causes the ride-on trowel to move to the left.

## CAUTION

Trowel arms can be damaged by rough handling or by striking exposed plumbing or forms while in operation. **ALWAYS** look-out for objects which might cause damage to the trowel arms.

## Maintenance

When performing any maintenance on the trowel or engine, follow all safety messages and rules for safe operation stated at the beginning of this manual.



## Maintenance Schedule

1. Check and retighten all fasteners as necessary.

### Daily (8-10 Hours)

1. Check the fluid levels in the engine and gearboxes, fill as necessary. Check Air Cleaner. See section on Air Cleaner servicing.

### Weekly (30-40 Hours)

1. Relube arms, thrust collar and steering links.
2. Replace blades if necessary.
3. Check and clean or replace the engine air filter as necessary. (See following section on Air Filter Maintenance.)
4. Replace engine oil and filter as necessary. (See following section on Oil and Filter.)

### Monthly (100-125 Hours)

1. Remove, clean, reinstall and relube the arms and thrust collar. Adjust the blade arms.
2. Replace gearbox lubricant after the first 100 hours of operation. Replace every 500-600 hours thereafter.
3. Check drive belt for excessive wear. (Refer to following section on Drive Belt maintenance.)

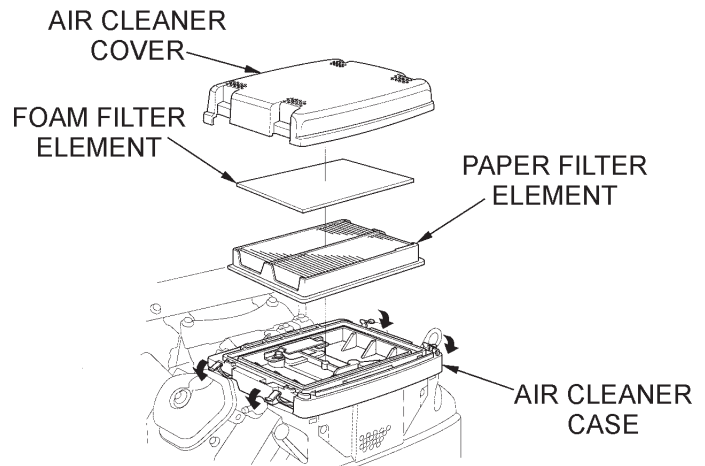
### Yearly (500-600 Hours)

1. Check and replace if necessary the arm bushings, and thrust collar bushings, shaft seals and belts.
2. Check pitch control cables for wear.
3. Replace gearbox lubricant.

## Air Cleaner (Daily)

Thoroughly remove dirt and oil from the engine and control area. Clean or replace the air cleaner elements as necessary. Check and retighten all fasteners as necessary.

1. Release the four latch tabs (Figure 12) from the air cleaner cover, and remove the cover.



**Figure 12. Air Cleaner Components**

2. Remove the foam filter from the cover.
3. Remove the paper filter from the air cleaner case.
4. Inspect both air filter elements, replace them if necessary.
5. To clean the paper air filter, tap the filter element several times on a hard surface to remove dirt, or blow compressed air (not to exceed 30 psi (207 kPa, 2.1 kgf/cm<sup>2</sup>) through the filter element from the air cleaner case side.
6. **NEVER!** try to brush off dirt; brushing will force dirt into the fibers. If the paper element is excessively dirt, replace element.
7. Clean the **foam air filter element** in warm soapy water, rinse and allow to dry thoroughly. Or clean with a nonflammable solvent and allow to dry. **DO NOT** pour any type of oil into the foam element.
8. Wipe dirt from the inside of the air cleaner body and cover, using a moist cloth. Be careful not to let any dirt or debris to enter the air chamber that leads to the carburetor.
9. Reinstall the foam air filter element to the air cleaner cover, then reinstall the paper air filter element and cover to the air cleaner case. Securely latch the four hook tabs on the air cleaner cover



## CAUTION

Operating the engine with a blocked grass screen, dirty or plugged cooling fins, and/or cooling shrouds removed, will cause engine damage due to overheating.

### Changing Engine Oil (100 Hours)

1. Change the engine oil after the first 20 hours of use, then change every 6 months or 100 hours.
2. Remove the oil filler cap (Figure 5, Item 1), and fill engine crankcase with recommended type oil as listed in Table 4. Fill to the upper limit of dipstick.
3. Crankcase oil capacity is 1.69 qts. (1.60 liters) without oil filter replacement, with oil filter replacement 2.02 qts. (1.90 liters).

### Oil Filter (200 Hours)

1. Replace the engine oil filter (Figure 13) every 200 hours.

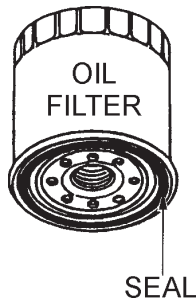


Figure 13. Oil Filter

2. Be sure to coat the **seal** of the new oil filter with clean engine oil.

### Fuel Filter (200 Hours)

1. Replace the engine fuel filter (Figure 14) every 200 hours.

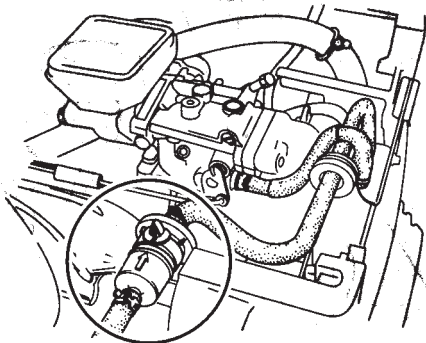


Figure 14. Honda Fuel Filter

### Oil And Fuel Lines

- Check the oil and fuel lines and connections regularly for leaks or damage. Repair or replace as necessary.
- Replace the oil and fuel lines every two years to maintain the line's performance and flexibility.

### Long Term Storage

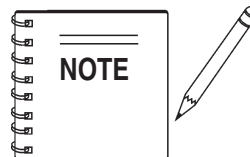
- Remove the battery.
- Drain fuel from fuel tank, fuel line and carburetor.
- Remove spark plug and pour a few drops of motor oil into cylinder. Crank engine 3 to 4 times so that oil reaches all internal parts.
- Clean exterior with a cloth soaked in clean oil.
- Store unit covered with plastic sheet in moisture and dust-free location out of direct sunlight.

## CAUTION

Never store the ride-on trowel with fuel in the tank for any extended period of time. Always clean up spilled fuel immediately.

### Engine Tune-Up

- See your engine manual for specific information on tuning up your engine, checking and gapping the spark plugs, etc.



See the engine manual supplied with your machine for appropriate engine maintenance schedule and troubleshooting guide for problems.

At the front of the book (Page 9) there is a "Daily Pre-Operation Checklist". Make copies of this checklist and use it on a daily basis.

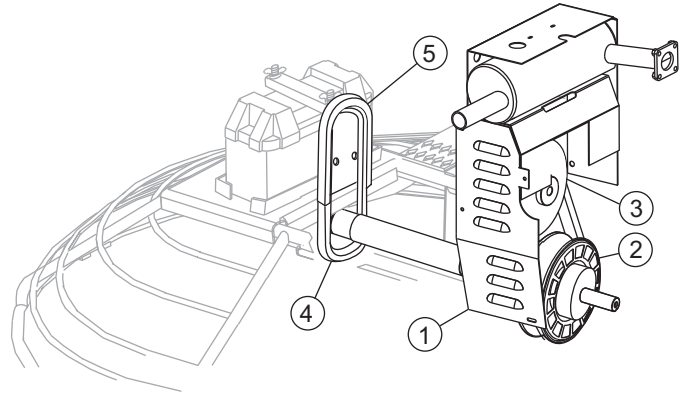
Disconnect spark plug wires and battery cables before attempting any service or maintenance on the ride-on trowel.

## Checking The Drive Belt

The drive belt needs to be replaced as soon as it starts to show signs of wear. Indications of excessive belt wear are fraying, squealing when in use, belts that emit smoke or a burning rubber smell when in use.

Under normal operating conditions, a drive belt may last approximately 150 hours. If your trowel is not reaching this kind of life span for drive belt wear, check the drive belt for proper pulley alignment and spacing.

To gain access to the drive belt, remove the drive belt guard cover (Item 1, Figure 16), then visually inspect the drive belt for signs of damage or excessive wear. If the drive belt is worn or damaged, replace the drive belt.




- 1 Drive Belt Guard Cover
- 2 Lower Pulley
- 3 Upper Pulley
- 4 Spare Drive Belt
- 5 Spare Drive Belt Holder

**Figure 16. Drive Belt Guard Cover**

1. Remove Drive Belt Guard Cover (Item 1, Figure 16).
2. Squeeze the drive belt as shown in Figure 17, and pull the V-belt upwards. This will spread open the faces of the **lower** drive pulley.


**⚠ WARNING**

**DO NOT** attempt to insert hands or tools into the belt area while the engine is running. **NEVER** run the engine with the safety guards removed. Keep fingers, hands, hair and clothing away from all moving parts to prevent bodily injury.



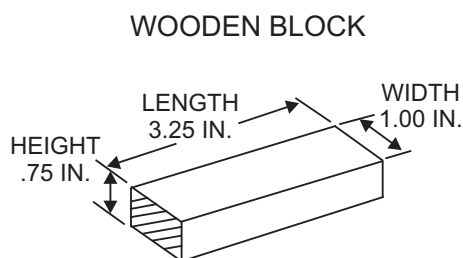
**⚠ WARNING**

**DO NOT** remove the drive belt guard cover until the muffler has cooled. Allow the entire trowel to cool down before performing this procedure.

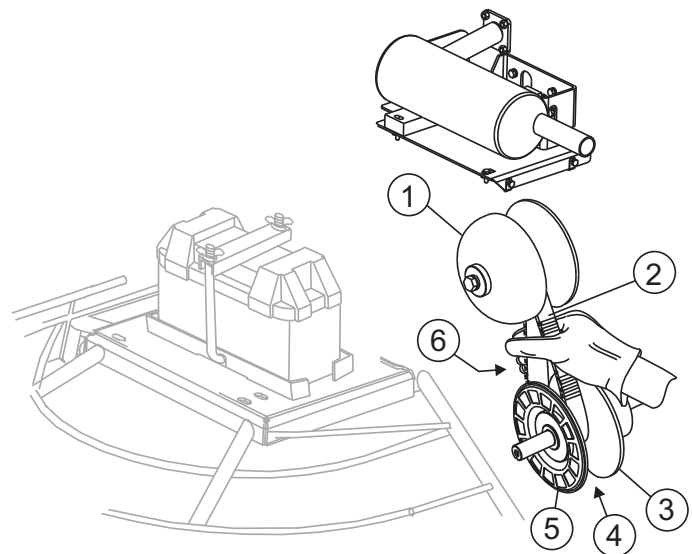


## Removing the Drive Belt

- Leave the existing drive belt intact until instructed to cut it.
- Leave the engine in place for this procedure. It is not necessary to slide the engine to replace the drive belt.
- Have a 3/4 X 1 X 3-1/4 inch wooden block available.



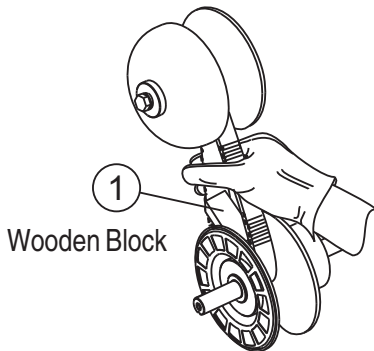
**Figure 15. Wooden Block For Spacer**



- 1 Upper Pulley
- 2 Drive Belt
- 3 Lower Pulley Fixed Face
- 4 Lower Pulley Spread Apart
- 5 Lower Pulley Movable Face
- 6 Squeeze and Pull Up To Spread Lower Pulley

**Figure 17. Expanding Lower Drive Pulley**

3. **Insert** the 3/4" X 1" X 3-1/4" block between the moveable face and the fixed face of the lower drive pulley. See Figure 18. This block will help keep the lower drive pulley faces open while installing the new drive belt.



**Figure 18. Holding Lower Pulley Open**

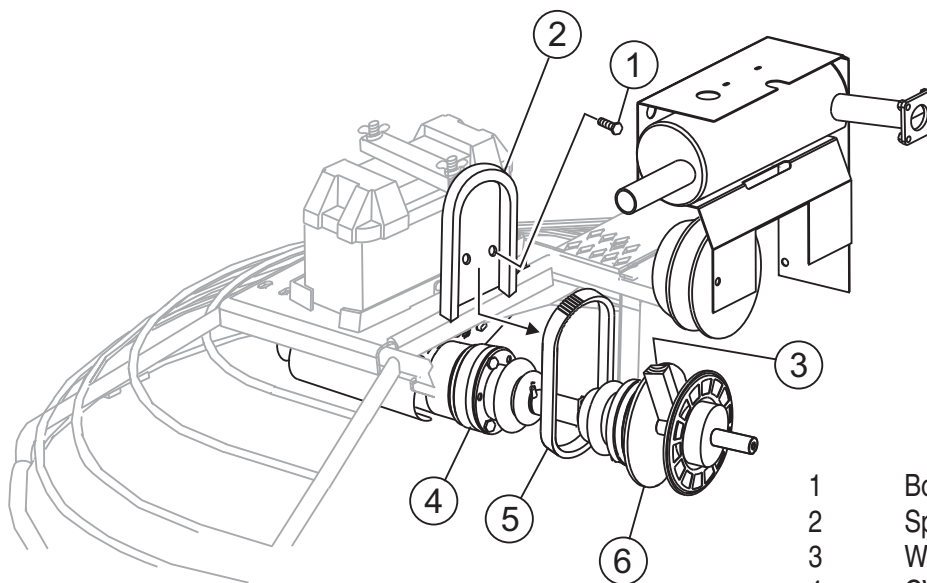
4. If the belt is not being reused (recommended), **CUT** the drive belt. Ensure all belt remnants are removed from the pulleys.

### Installing the Drive Belt (Using Replacement Drive Belt)

The JWN-SERIES Ride-On Power Trowel is equipped with a replacement drive belt (spare) carrier, which is mounted on the inboard side of the fuel tank near the clutch. Make sure that there is **ALWAYS** a spare drive belt in the drive belt carrier before the trowel is placed on a slab to finish concrete.

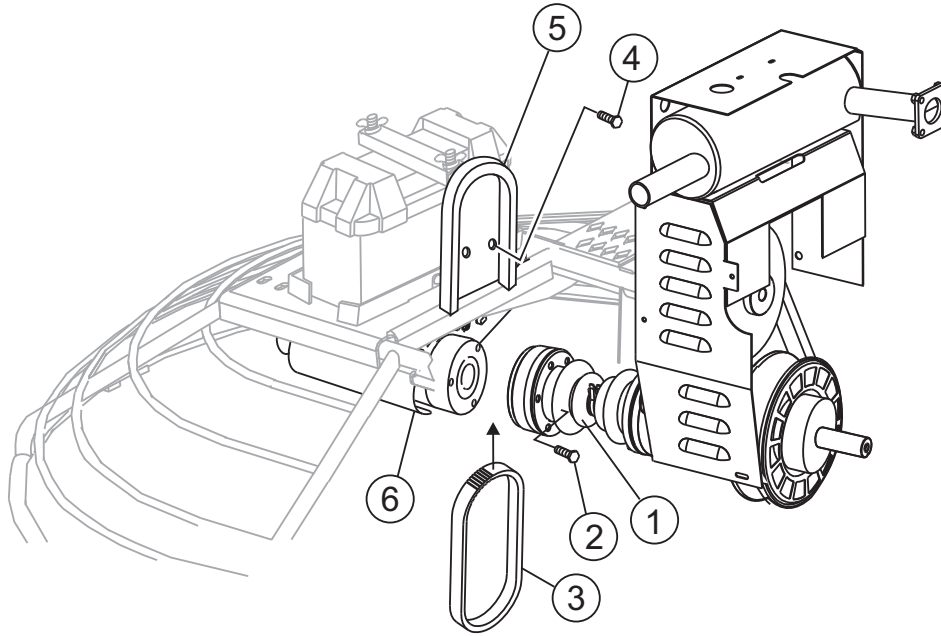
In the event of a drive belt failure, the spare (replacement) drive belt can be used for quick replacement at the job site to continue trowel operation.

1. If necessary, refer to Removing Drive Belt Instructions. Ensure all remnants of old belt have been removed from pulleys.
2. To replace the drive belt with the spare drive belt, remove the 2 bolts that secure the drive belt carrier. (Figure 19) This will allow free movement of the belt for installation. Take care with to not contaminate the replacement belt with grease or dirt.
3. With the 3/4 x 1 x 3-1/4 wood block holding the lower pulley open, place the replacement belt into the lower pulley first. Work the belt over the upper drive pulley into the pulley groove.
4. Squeeze the belt enough to remove the wood block. With the block removed, release the tension on the belt.
5. Reinstall the spare belt carrier and the drive belt guard.
6. Replace the spare belt before the next trowel use. See spare drive belt replacement procedures.



**Figure 19. Drive Belt Install**

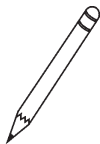
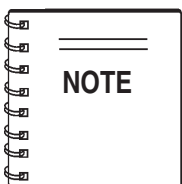
- 1 Bolt, Spare Drive Belt Carrier
- 2 Spare Drive Belt Holder
- 3 Wooden Block
- 4 CV-Joint
- 5 New Spare Drive Belt
- 6 Lower Drive Pulley



- 1 CV Joint
- 2 Bolt (Remove 3 places)
- 3 New Spare Drive Belt
- 4 Bolt, Spare Drive Belt Carrier
- 5 Spare Drive Belt Holder
- 6 Left Side Gearbox

**Figure 20. Spare Drive Belt Replacement**

## Spare Drive Belt Replacement



It **will** be necessary to disconnect the CV-Joint from the left-side gearbox coupler. This means the removal of the three screws that secure the CV-Joint to the gearbox.

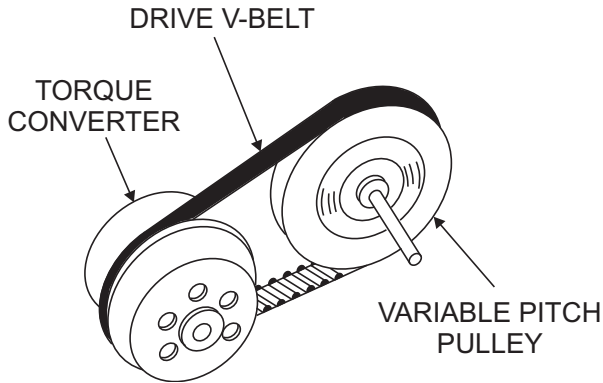
To replace a spare drive belt, be prepared to disconnect the CV-joint from the left-side gearbox. See Figure 20.

1. Place the trowel on suitable supports and observe all safety precautions.
2. Remove the three screws that secure the CV-joint to the left-side gearbox coupler.
3. Once the CV-joint has been separated from the left-side gearbox, push the CV-joint inward so that a gap exists between the gearbox and the CV-joint (Figure 20). Slide the spare V-belt between the gearbox coupler and the CV-joint. Avoid contaminating the replacement belt with grease or oil when sliding it between the CV-Joint and gearbox coupler.
4. Place the spare drive belt inside the drive belt carrier, and secure the spare belt carrier to the inboard side of the left gearbox.
5. Install the three screws that secure the CV-joint to the left-side gearbox coupler.

# JWN-SERIES— MAINTENANCE

The JWN-Series Ride-On Power Trowel is equipped with a "Torque Converter" which supplies torque to both the left and right gearboxes. The function of the torque converter is to automatically deliver the correct amount of torque required by the trowel under all load conditions. This enables the trowel to deliver the necessary torque for float pan applications and the high rotor speeds required for burnishing concrete.

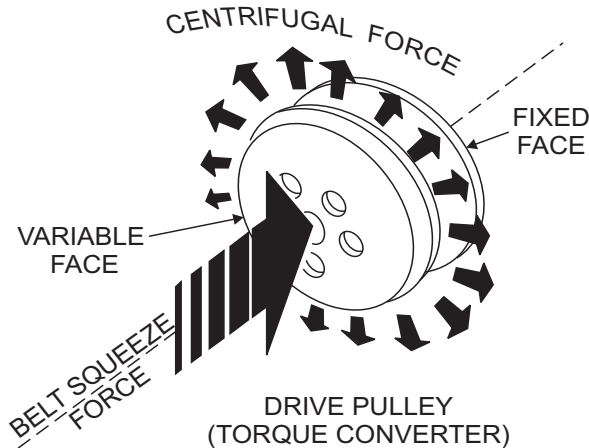
The torque converter used in the JWN Series Ride-On Power Trowel is a variable pitch pulley type (Figure 21) connected by a drive belt.



**Fig. 21. Torque Converter/Variable Pitch Pulley**

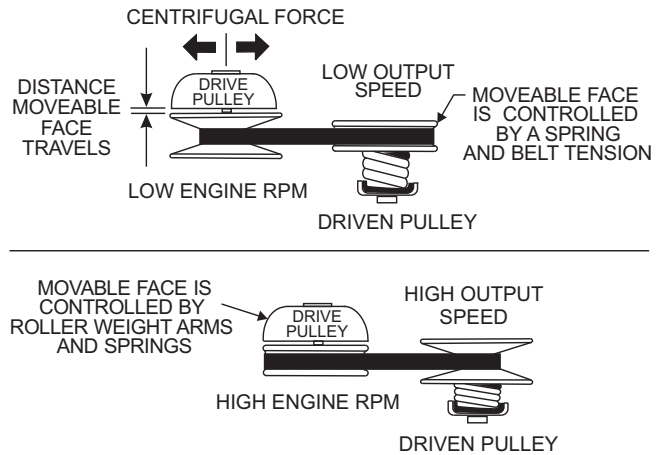
## Drive Pulley

The "Drive Pulley" uses centrifugal force (Figures 22 and 23) to create a belt squeeze force transmitted at the pulley faces. This condition functions as an automatic clutch.



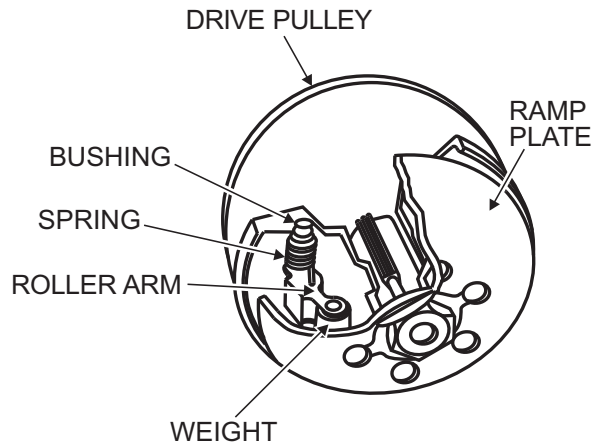
**Figure 22. Torque Converter (Centrifugal Force)**

As shown in Figure 23, centrifugal force pushes the roller arms (see Figure 23 below) against the ramp plate, forcing moveable face toward fixed face squeezing belt.

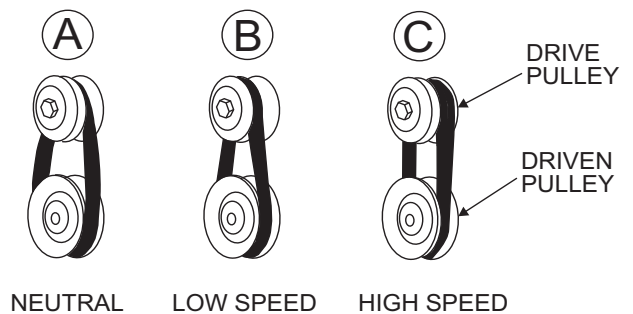


**Fig. 23. Pulley Interaction**

The "Variable Pitch Pulleys" have one *fixed face*, and one *moveable face*. The *drive* pulley (torque converter, Figure 24) moveable face is controlled by roller weight arms and springs, which change position according to engine speed. The *driven* pulley *moveable face* is controlled by a spring and belt tension.



**Fig. 24. Variable Pitch Pulley**



**Figure 25. Pulley Conditions**

## How It Works (Figure 24)

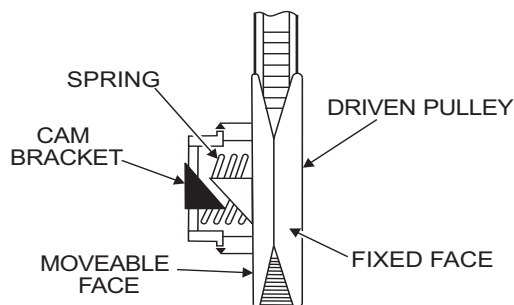
- Condition A:**
- Engine Idling
  - Drive Pulley: Small
  - Driven Pulley: Large
  - Belt: Loose and Stationary
- Condition B:**
- Engine Accelerating
  - Drive Pulley: Small But Increasing
  - Driven Pulley: Large But Decreasing
  - Belt: Approaching Tightness
- Condition C:**
- Engine At High Speed
  - Drive Pulley: Large
  - Driven Pulley: Small
  - Belt: Tight

## Clutch

This clutch system provides a high pulley ratio (a low gear- so to speak) to start out and a low pulley ratio ( a high gear- so to speak) for a high speed operation, with infinite variation between the two.

This means that it will not be necessary to give **full throttle** in order to "break the blades/pans loose". The machine can slowly be brought up to speed.

The torque sensitive pulley (Figure 25) utilizes a spring and cam bracket. Peak performance results from proper interaction between the driven pulley spring and the ramp angle of the cam bracket.



**Figure 26 . Pulley Spring and Cam Bracket**

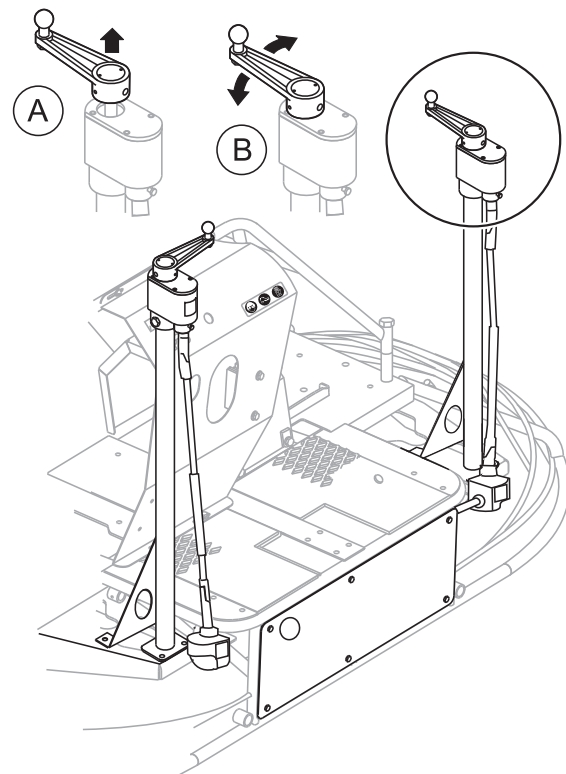
## Blade Pitch

Sometimes it may be necessary to match blade pitch between the two sets of blades. There are some signs that this may be necessary. For example, the differences in pitch could cause a noticeable difference in finish quality between the two sets of blades. Or, the difference in blade pitch could make the machine difficult to control. This is due to the surface area in contact with the concrete (the blade set with the greater contact area tends to stick to the concrete more).

## Matching Blade Pitch for Both Sets of Blades

Trowels equipped with optional **Twin Pitch™** Controls may need to have blade pitch between the two sets of blades "synchronized". If the blades need to be synchronized this is easily accomplished by performing the following. Refer to Figure 27.

1. Lift the pitch adjustment handle on either side. Once lifted, that side is now disconnected from the **Twin Pitch™** system.
2. Adjust to match the opposite side.
3. When adjusted, lower the handle to **Twin Pitch™** operating position.

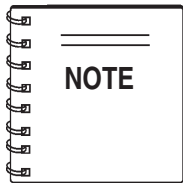


- A **Twin Pitch™** disengaged (one side)  
 B Operating Position

**Figure 27. Pitch Towers**

# JWN-SERIES TROWEL — MAINTENANCE

## Trowel Arm adjustment Procedure



The following procedure should be followed to adjust trowel arms when it becomes apparent that the trowel is finishing poorly or in need of routine maintenance.

A **level**, clean area to test the trowel prior to and after adjustment is essential. Any unlevel **spots** in the floor or debris under the trowel blades will give an incorrect perception of adjustment. Ideally, a 5' x 5' three-quarter inch thick **flat** steel plate should be used for testing.

1. To determine which blades need adjustment, place the trowel in the test area (three-quarter inch thick plate) and look for the following conditions:

- Pitch the blades as flat as possible and look at the **adjustment bolts**. They should all barely make contact with the **lower wear plate** on the spider. If you can see that one of them is not making contact, some adjustment will be necessary.
- Is the machine wearing out blades unevenly (i.e. one blade is completely worn out while the others look new)?

Figure 28 illustrates "**worn spider bushings or bent trowel arms**". Check to see that adjustment bolt is barely touching (0.10" max. clearance) lower wear plate. All alignment bolts should be spaced the same distance from the lower wear plate.

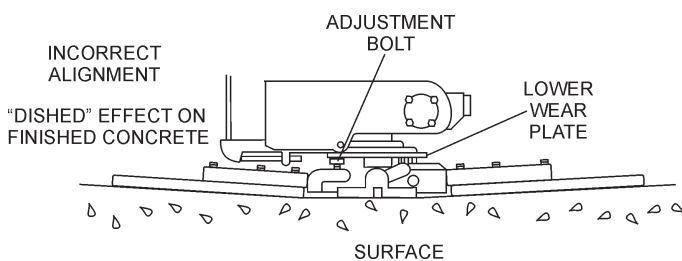


Figure 28. Worn Arm Bushings

Figure 29 illustrates the "**correct alignment**" for a spider plate (as shipped from the factory).

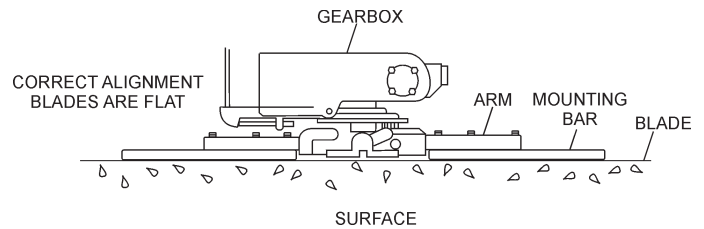


Figure 29. Correct Spider Plate Alignment

2. Start engine, and bring trowel blades up to full speed and look for the following conditions:
- Does the trowel have a perceived rolling or bouncing motion?
  - Does the guard ring "rock up and down" relative to the ground?

## Stabilizer Ring Removal

1. If the trowel is equipped with an outer stabilizer ring (Figure 30), remove the four bolts at the end of each spider arm.

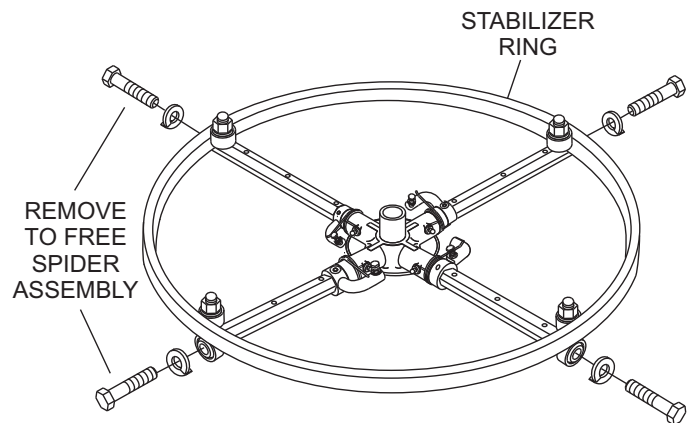


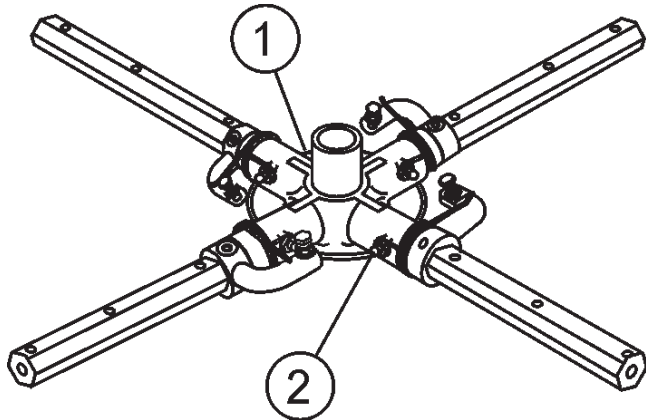
Figure 30 Stabilizer Ring

2. Examine stabilizer ring for out of round or bends. If ring is damaged, replace ring. If ring is found to be correct with no damage, set aside.

# JWN-SERIES TROWEL — MAINTENANCE

## Trowel Arm Removal

1. Each trowel arm is held in place at the spider plate by a hex head bolt (with zerk grease fitting). Remove the hex head bolt/zerk grease fitting from the spider plate. (Figure 31)
2. Remove the trowel arm from the spider plate.



- 1 Spider Plate
- 2 Hex Head Bolt (Zerk Fitting)

Figure 31. Removing Zerk Grease Fitting

## Trowel Blade Removal

1. Remove the trowel blades from the trowel arm by removing the three hex head bolts (Figure 33) from the trowel arm. Set blades aside.

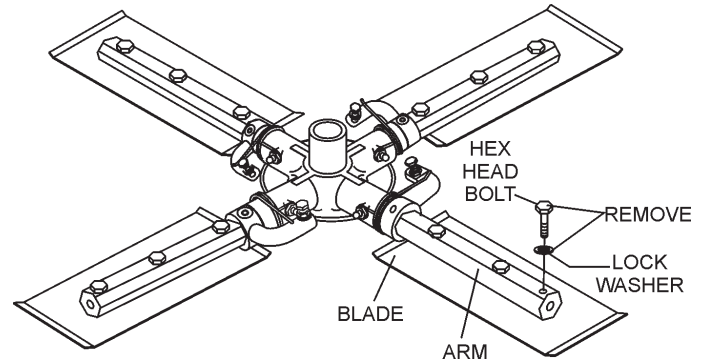


Figure 33. Trowel Blades

2. **Wire brush** any build-up of concrete from all six sides of the trowel arm. Repeat this for the remaining three arms.

3. Should the trowel arm inserts (bronze bushing ) come out with the trowel arm, remove the bushing from the trowel arm and set aside in a safe place. If the bushing is retained inside the spider plate, carefully remove the bushing.
4. Examine the bronze trowel arm bushing insert (Figure 32), clean if necessary. Replace bushing if out-of-round or worn.

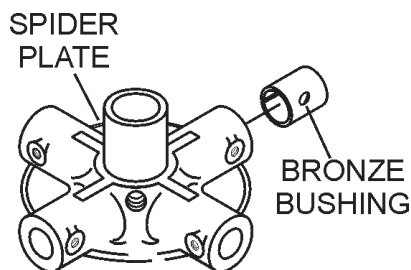


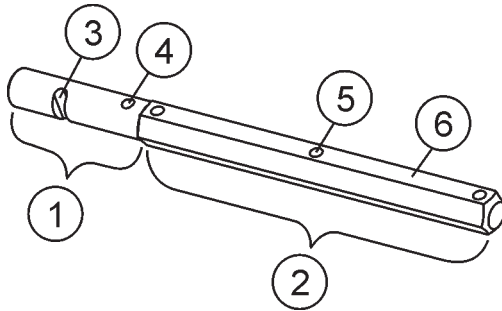
Figure 32. Bronze Bushings



# JWN-SERIES TROWEL — MAINTENANCE

## Checking Trowel Arm Straightness

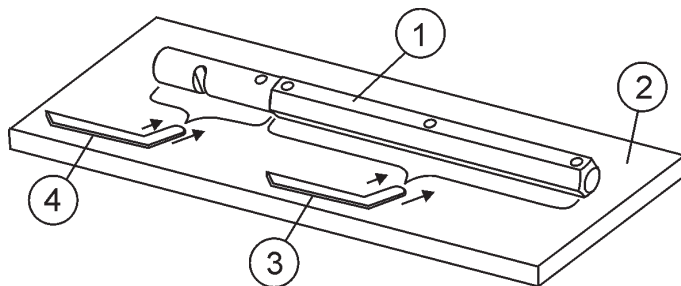
Trowel arms can be damaged by rough handling, (such as dropping the trowel on the pad), or by striking exposed plumbing, forms, or rebar while in operation. A bent trowel arm will not allow the trowel to operate in a smooth fluid rotation. If bent trowel arms are suspect, check for flatness as follows, refer to Figures 34 and 35.



- 1 Trowel Arm Round Shaft Section
- 2 Trowel Arm Hexagonal (Hex) Shaft Section
- 3 Lever Mounting Slot (Left Arm Shown)
- 4 Roll Pin Hole
- 5 Blade Attachment Bolt Hole (One of Three)
- 6 Flat of Hexagonal Shaft (Top of Arm)

**Figure 34. Trowel Arm**

1. Use a thick steel plate, granite slab or any surface which is **true** and **flat**, to check all **six sides** of each trowel arm for flatness.
2. Check each of the six sides of the trowel arm (hex section). A feeler gauge of .004" (0.10 mm) should not pass between the flat of the trowel arm and the test surface along its length on the test surface. (Figure 35, Item 3).



- 1 Trowel Arm
- 2 Flat Test Surface
- 3 Feeler Gauge (.004 in. / 0.10 mm)
- 4 Feeler Gauge (.005 in. / 0.127 mm)

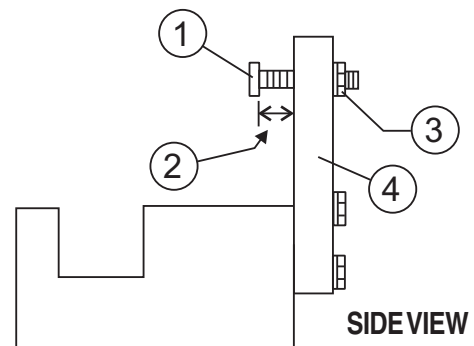
**Figure 35. Checking Trowel Arm Flatness**

3. Next, check the clearance between the round shaft and the test surface as one of the flat hex sections of the arm rests on the test surface. Rotate the arm to each of the flat hex sections and check the clearance of the round shaft. Use a feeler gauge of .005" (0.127 mm). Each section should have the **same clearance** between the round of the trowel arm shaft and the test surface.
4. If the trowel arm is found to be **uneven** or **bent**, replace the trowel arm.

## Trowel Arm Adjustment

Shown in (Figure 38) is the adjustment fixture with a trowel arm inserted. As each trowel arm is locked into the fixture, the arm bolt is adjusted to where it contacts a stop on the fixture. This will consistently adjust all of the trowel arms, keeping the finisher as flat and evenly pitched as possible.

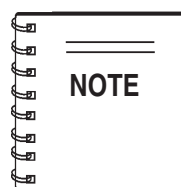
1. Locate the trowel arm adjustment tool P/N 9177.



- 1 Adjustment Bolt
- 2 "Distance"
- 3 Locking Nut
- 4 Fixture Arm

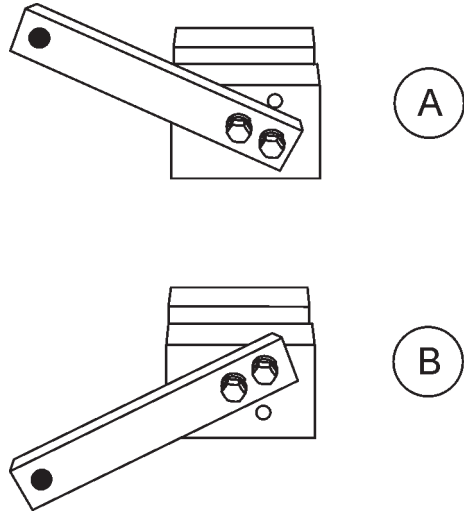
**Figure 36. Trowel Arm Adjustment Tool Side View**

2. Ensure the fixture arm is in the proper setting (up or down) for your trowel arm rotation as shown in Figure 37.



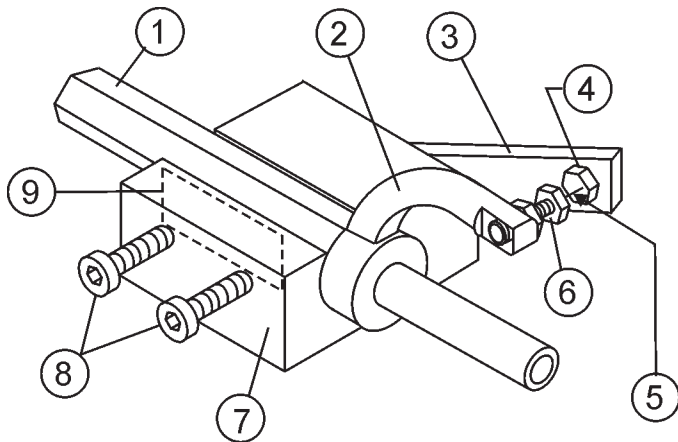
Arms with **CLOCK-WISE** blade rotation use the fixture arm in the **UP** position (A in Figure 37). Arms with **COUNTER CLOCK-WISE** blade rotation use the fixture with the fixture arm in the **DOWN** position. (B in Figure 37).

# JWN-SERIES TROWEL — MAINTENANCE



**Figure 37. Trowel Arm Adjustment Setup**

3. Unscrew the locking bolts on the adjustment tool and place the trowel arm into the fixture channel as shown in Figure 38. A **thin shim** may be required to cover the blade holes on the trowel arm. Make sure to align the **trowel** adjustment bolt with the **fixture** adjustment bolt.



- |   |                               |
|---|-------------------------------|
| 1 | Arm                           |
| 2 | Trowel Arm Lever              |
| 3 | Fixture Arm                   |
| 4 | Adjustment Bolt               |
| 5 | Distance = .010 Inch          |
| 6 | Adjustment Bolt               |
| 7 | Trowel Arm Adjustment Fixture |
| 8 | Locking Bolts                 |
| 9 | Shim                          |

**Figure 38. Trowel Arm Adjustment Fixture Components**

4. Use an allen wrench to tighten the locking bolts securing the trowel arm in place.
5. Adjust the bolt "distance" shown in Figure 36 to match one of the arms. The other arms will be adjusted to match this distance.
6. Loosen the locking nut on the trowel arm lever, then turn the trowel arm adjusting bolt until it barely touches (.010") the fixture adjusting bolt.
7. Once the correct adjustment is made, tighten the lock nut on the trowel arm to lock in place.
8. Loosen locking nuts on the adjustment fixture, and remove trowel arm.
9. Repeat steps for the remaining trowel arms.

## Re-Assembly

1. Clean and examine the upper/lower wear plates and thrust collar. Examine the entire spider assembly. Wire brush any concrete or rust build-up. If any of the spider components are found to be damaged or out of round, replace them.
2. Make sure that the bronze trowel arm bushing is not damaged or out of round. Clean the bushing if necessary. If the bronze bushing is damaged or worn, replace it.
3. Reinstall bronze bushing onto trowel arm.
4. Repeat steps 2-3 for each trowel arm.
5. Make sure that the spring tensioner is in the correct position to exert tension on the trowel arm.
6. Insert all trowel arms with levers into spider plate (with bronze bushing already installed) using care to align grease hole on bronze bushing with grease hole fitting on spider plate.
7. Lock trowel arms in place by tightening the hex head bolt with zerk grease fitting and jam nut.
8. Re-install the blades onto the trowel arms.
9. Install stabilizer ring onto spider assembly.
10. Lubricate all grease points (zerk fittings) with premium "**Lithum 12**" based grease, conforming to NLG1 Grade #2 consistency.

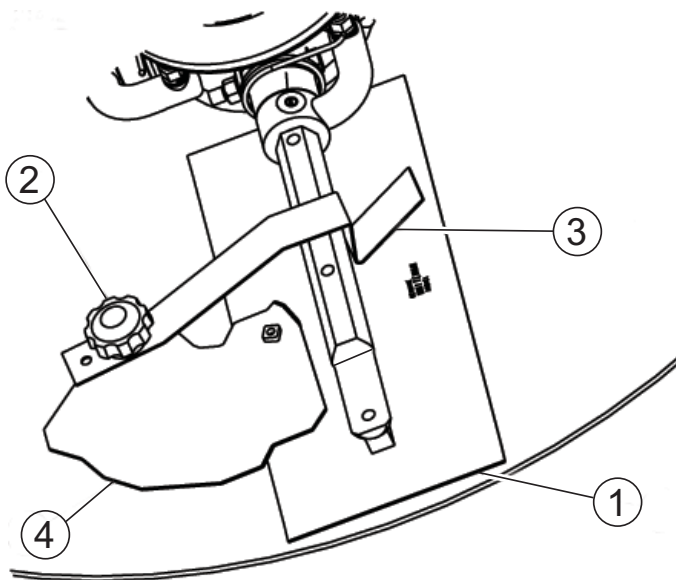
# JWN-SERIES TROWEL — MAINTENANCE

## Installing Pans Onto Finisher Blades

These round discs sometimes referred to as "pans" attach to the spiders arms and allow early floating on wet concrete and easy movement from wet to dry areas. They are also very effective in embedding large aggregates and surface hardeners.



Refer to Figure 39 when installing pans onto finisher blades.



- 1 BLADE ASSEMBLY
- 2 KNOB, TIE-DOWN Z-CLIP PANS
- 3 TIE-DOWN, BLADE
- 4 Z-CLIP, PAN

Figure 39. Z-Clip Finisher Pan Installation

1. Lift trowel just enough to slide pan under blades. Lower finisher onto pan with blades (Item #1) adjacent to Z-Clips (Item #4).
2. Rotate blades into position under Z-Clips. Ensure that the blades are rotated in the direction of travel when the machine is in operation or use the engine to rotate the blades into position.
3. Attach the blade tie-downs (Item #3) to the far side of the Z-Clip brackets (Item #4) with tie-down knobs (Item #2) as shown in figure 39.
4. Check to make certain that the blade edges are secured under the Z-Clips and the tie-downs are secured completely over the edges of the blade bar before the machine is put back into operation.

## Decommissioning Trowel/Components

Decommissioning is a controlled process used to safely retire a piece of equipment that is no longer serviceable. If the equipment poses an unacceptable and unrepairable safety risk due to wear or damage or is no longer cost effective to maintain, (beyond life-cycle reliability) and is to be decommissioned, (demolition and dismantlement), the following procedure must take place:

1. Drain all fluids completely. These may include oil, gasoline, hydraulic oil and antifreeze. Dispose of properly in accordance with local and governmental regulations. Never pour on ground or dump down drains or sewers.
2. Remove battery and bring to appropriate facility for lead reclamation. Use safety precautions when handling batteries that contain sulfuric acid, (See page 14).
3. The remainder can be brought to a salvage yard or metal reclamation facility for further dismantling.

# JWN-SERIES TROWEL — TROUBLESHOOTING (ENGINE)

**TABLE 5. ENGINE TROUBLESHOOTING**

SYMPTOM	POSSIBLE PROBLEM	SOLUTION
<b>Engine Cranks But Will Not Start</b>	Fuel tank is empty.	Fill fuel tank.
	Shut-off valve is closed.	Open fuel shut-off valve.
	Fuel line has suction leak or is restricted. Fuel filter, or fuel tank cap vent is obstructed.	Check fuel line condition and fuel line clamps. Ensure that fuel line is not kinked. Check fuel filter for restriction and replace if necessary. Check fuel cap vent and clean or replace as necessary.
	Fuel supply is contaminated.	Drain and clean fuel tank, clean tank and refill with fuel.
	If carbureted, carburetor is underchoked or overchoked.	Apply recommended amount of choke for cold and warm weather.
	Spark plug is fouled, improperly gapped, or damaged. Spark plug leads disconnected.	Check spark plug for fouling, check gap, and inspect for damage. Clean or replace spark plug as necessary. Reattach spark plug leads if disconnected.
	Safety stop switch malfunction.	Ensure that the Safety Stop Switch is functioning when the operator is seated; replace switch if necessary.
<b>Engine Starts But Will Not Continue Running</b>	Fuel tank is empty.	Fill fuel tank.
	Shut-off valve is closed.	Open fuel shut-off valve.
	Fuel line has suction leak or is restricted. Fuel filter is obstructed, or fuel tank cap vent is blocked.	Check fuel line condition and fuel line clamps. Ensure that fuel line is not kinked. Check fuel filter for restriction and replace if necessary. Check fuel cap vent and clean or replace as necessary.
	If engine is carbureted, carburetor is underchoked or over choked.	Apply recommended amount of choke for cold and warm weather.
	Faulty ignition switch or starter.	Replace defective switch or starter.
	Engine is seized.	Repair or replace engine.

# JWN-SERIES TROWEL — TROUBLESHOOTING (ENGINE)

**TABLE 5 CONT.. ENGINE TROUBLESHOOTING**

SYMPTOM	POSSIBLE PROBLEM	SOLUTION
<b>Engine Lacks Power</b>	Air filter is obstructed.	Replace air filter.
	Altitude causes 3% loss of horsepower per 1000 feet of altitude.	If available, install high altitude jets in carburetor.
	Choke is partially closed.	Open choke.
	Faulty spark plugs or spark plug leads. Spark plug lead disconnected.	Replace spark plugs or spark plug leads if faulty. Reattach spark plug lead if disconnected.
	Fuel is contaminated.	Drain and clean fuel tank. Refill with clean fuel.
	There is a lack of lubrication.	Check engine oil.
	Engine is overheated	Allow engine to cool. Find and repair cause of overheating.
	Exhaust is restricted.	Remove or repair restriction.
	Ignition timing incorrect.	Set engine ignition timing to manufacturer's specification.
<b>Engine Overheats</b>	Ignition timing incorrect.	Set engine ignition timing to manufacturer's specification.
	Fuel mixture is too lean.	Look for intake system leak. Repair any leaks found.
	Exhaust is restricted.	Remove or repair restriction.
	Fan shroud or fan is broken or missing.	Replace fan shroud.
	Coolant level is low.	Fill radiator when cool. Add coolant to fill line on reservoir.
	Low or Hi crankcase oil level	Check engine oil. Fill if low, drain if overfilled.
<b>Engine Will Not Crank</b>	Battery is discharged or defective.	Charge and test battery. Replace if defective.
	Loose or faulty wires or connections.	Inspect wiring, repair any bad connections or wires.
	Faulty ignition switch or starter.	Replace defective switch or starter.
	Engine is seized.	Repair or replace engine.

# JWN-SERIES TROWEL — TROUBLESHOOTING (TROWEL)

TABLE 6. TROUBLESHOOTING

SYMPTOM	POSSIBLE PROBLEM	SOLUTION
Engine running rough or not at all.	Safety Stop Switch malfunction?	Make sure that the Safety Stop Switch is functioning when the operator is seated; replace switch if necessary.
	Fuel?	Look at the fuel system. Make sure there is fuel being supplied to the engine. Check to ensure that the fuel filter is not clogged.
	Ignition?	Check to ensure that the ignition switch has power and is functioning correctly.
	Other problems?	Consult engine manufacturer's manual.
Safety Stop Switch not functioning.	Loose wire connections?	Check wiring. Replace as necessary.
	Bad contacts?	Replace switch.
If trowel "bounces, rolls concrete, or makes uneven swirls in concrete".	Blades?	Make certain blades are in good condition, not excessively worn. Finish blades should measure no less than 2" (50mm) from the blade bar to the trailing edge, combo blades should measure no less than 3.5" (89mm). Trailing edge of blade should be straight and parallel to the blade bar.
	Spider?	Check that all blades are set at the same pitch angle as measured at the spider. A field adjustment tool is available for height adjustment of the trowel arms (see Optional Equipment).
	Bent trowel arms?	Check the spider assembly for bent trowel arms. If one of the arms is even slightly bent, replace it immediately.
	Trowel arm bushings?	Check the trowel arm bushings for tightness. This can be done by moving the trowel arms up and down. If there is more than 1/8" (3.2 mm) of travel at the tip of the arm, the bushings should be replaced. All bushings should be replaced at the same time.
	Thrust collar?	Check the flatness of the thrust collar by rotating it on the spider. If it varies by more than 0.02" (0.5 mm) replace the thrust collar.
	Thrust collar bushing?	Check the thrust collar by rocking it on the spider. If it can tilt more than 1/16" (1.6 mm) [as measured at the thrust collar O.D.], replace the bushing in the thrust collar.
	Thrust bearing worn?	Check the thrust bearing to see that it is spinning free. Replace if necessary.
	Blade pitch?	Check blades for consistent pitch. Adjust per Maintenance section instructions if necessary.
Machine has a perceptible rolling motion while running.	Main shaft?	The main output shaft of the gearbox assembly should be checked for straightness. The main shaft must run straight and cannot be more than 0.003" (0.08 mm) out of round at the spider attachment point.
	Yoke?	Check to make sure that both fingers of the yoke press evenly on the wear cap. Replace yoke as necessary.

# JWN-SERIES TROWEL — TROUBLESHOOTING (TROWEL)

TABLE 7. TROUBLESHOOTING (CONTINUED)

SYMPTOM	POSSIBLE PROBLEM	SOLUTION
Lights (optional) not working.	Wiring?	Check all electrical connections, including the master on/off switch and check to see if wiring is in good condition with no shorts. Replace as necessary.
	Lights?	Check to see if light bulbs are still good. Replace if broken.
Retardant spray (optional) not working.	Retardant?	Check the tank to make sure retardant is present. Fill tank as necessary.
	Wiring?	Check all electrical connections, including master on/off switch connections. Replace components and wiring as necessary.
	Bad switch?	Check the continuity of master on/off switch. Replace if broken.
	Bad spray pump?	If pump has a voltage present when the switch is turned on, but does not operate and electrical connections to the pump are good, replace the pump.
Steering is unresponsive.	Blade speed out of adjustment?	See section on blade speed adjustment.
	Worn components?	Check for wear of steering bearings and linkage components replace if necessary.
	Pivots?	Check to ensure free movement of hydraulic drive motors.
	Hydraulic pressure?	Check to ensure that hydraulic pressure is adequate. See section on checking hydraulic pressure.
Operating position is uncomfortable.	Seat adjust for operator?	Adjust seat with lever located on the front of the seat.
Power head on Electric Pitch (optional) not working.	Broken or loose parts?	If the motor runs and the pitch is not affected, parts inside the power head may be loose or broken. Return power head to dealer for service.
	Wiring?	Check all electrical connections and wiring. Check the continuity at the power head unit. Verify that there is voltage present at the power head switch with the key switch in the "on" position.
	Switch?	Check the continuity of the switch. If switch is malfunctioning, replace immediately.
Linkage on Twin Pitch (optional) not working.	Crank handles?	Make sure that both crank handles are pushed down as far as possible. Doing this ensures that the linkage is engaged.
	Broken part?	Replace all broken parts immediately.

# EXPLANATION OF CODE IN REMARKS COLUMN

The following section explains the different symbols and remarks used in the Parts section of this manual. Use the help numbers found on the back page of the manual if there are any questions.

The contents and part numbers listed in the parts section are subject to change **without notice**. Multiquip does not guarantee the availability of the parts listed.

Sample Parts List:

NO.	PART NO.	PART NAME	QTY.	REMARKS
1	12345	BOLT .....	1	INCLUDES ITEMS W/*
2*		WASHER, 1/4 IN. ....		NOT SOLD SEPARATELY
2*	12347	WASHER, 3/8 IN. ...	1	MQ-45T ONLY
3	12348	HOSE .....	A/R	MAKE LOCALLY
4	12349	BEARING .....	1	S/N 2345B AND ABOVE

## NO. Column

**Unique Symbols** - All items with same unique symbol (\*, #, +, %, or >) in the number column belong to the same assembly or kit, which is indicated by a note in the "Remarks" column.

**Duplicate Item Numbers** - Duplicate numbers indicate multiple part numbers are in effect for the same general item, such as different size saw blade guards in use or a part that has been updated on newer versions of the same machine.



When ordering a part that has more than one item number listed, check the remarks column for help in determining the proper part to order.

## PART NO. Column

**Numbers Used** - Part numbers can be indicated by a number, a blank entry, or TBD.

TBD (To Be Determined) is generally used to show a part that has not been assigned a formal part number at time of publication.

A blank entry generally indicates that the item is not sold separately or is not sold by Multiquip. Other entries will be clarified in the "Remarks" Column.

## QTY. Column

**Numbers Used** - Item quantity can be indicated by a number, a blank entry, or A/R.

A/R (As Required) is generally used for hoses or other parts that are sold in bulk and cut to length.

A blank entry generally indicates that the item is not sold separately. Other entries will be clarified in the "Remarks" Column.

## REMARKS Column

Some of the most common notes found in the "Remarks" Column are listed below. Other additional notes needed to describe the item can also be shown.

**Assembly/Kit** - All items on the parts list with the same unique symbol will be included when this item is purchased.

Indicated by:

"INCLUDES ITEMS W/(unique symbol)"

**Serial Number Break** - Used to list an effective serial number range where a particular part is used.

Indicated by:

"S/N XXXXX AND BELOW"

"S/N XXXX AND ABOVE"

"S/N XXXX TO S/N XXXX"

**Specific Model Number Use** - Indicates that the part is used only with the specific model number or model number variant listed. It can also be used to show a part is NOT used on a specific model or model number variant.

Indicated by:

"XXXXX ONLY"

"NOT USED ON XXXX"

**"Make/Obtain Locally"** - Indicates that the part can be purchased at any hardware shop or made out of available items. Examples include battery cables, shims, and certain washers and nuts.

**"Not Sold Separately"** - Indicates that an item cannot be purchased as a separate item and is either part of an assembly/kit that can be purchased, or is not available for sale through Multiquip.

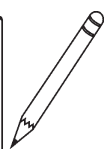
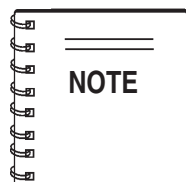


# JWN-SERIES— SUGGESTED SPARE PARTS

## JWN-SERIES - HONDA GX 670 - TAF 24 HP ENGINE

### 1 Unit

Qty.	P/N	Description	Qty.	P/N	Description
			10	10031	WASHER 1/4 IN.
			1	12548	SPRAY PUMP
			1	392292	SPRAY NOZZEL
4	20409	TROWEL ARM, LH	1	2108	CAP, SPRAY TANK
4	20408	TROWEL ARM, RH	1	2673	CIRCUIT BREAKER 30A, 12V
4	1163	LEVER TROWEL ARM (L.S.)	1	4682	TOGGLE SWITCH
4	1555	LEVER TROWEL ARM (R.S.)	1	8381	BOOT, TOGGLE SWITCH
2	10968	THRUST COLLAR KIT	1	2655	HOUR METER
2	12478	SPIDER KIT	1	12005	SAFETY-OFF ("KILL" SWITCH)
20	0166A	WASHER	1	12018	CONNECTOR, RELAY
20	1876	JAM NUT	1	12017	RELAY, ("KILL" SWITCH)
20	0164B	SCREW	1	16910ZE8015	FUEL FILTER
4	1157A	BUSHING	1	17210ZJ1841	AIR FILTER ELEMENT
4	1316	SPRING (L.S.)	1	15410ZJ4999AH	OIL FILTER
4	2143	SPRING (R.S.)	2	9807952876	SPARK PLUG - NGK
20	1875	WASHER	1	15611MB0000	OIL FILTER CAP
20	1322	SCREW ASSY., ARM RETAINING	1	17218Z51840	FILTER, OUTER, AIR
20	1162A	CAP GREASE FITTING			
4	0131A	SCREW (HHC 1/4 - 20 X 3/4)			
4	0948	WASHER, FLAT			
1	20384	BELT, DRIVE CVT			
20	0181B	WASHER 1/4 IN			
1	11418	FUEL CAP/GAUGE (ENG)			
1	19633	BUSHING, RUBBER FUEL			
1	20348	CABLE, THROTTLE (FOOT PEDAL)			
1	2153	ROD END, FEM RH (THROTTLE CABLE)			
6	2064	ROD END, FEM RH 3/8-24 (STEERING)			
4	2063	ROD END, MALE RH 3/8-24 (STEERING)			
2	11142	ROD END, MALE RH 1/2-20 (STEERING)			
4	BLADE ASSY.	CONTACT UNIT SALES DEPT/ ACCESSORY ITEM			



Part numbers on this Suggested Spare Parts List may supersede/replace the P/N shown in the text pages of this book.



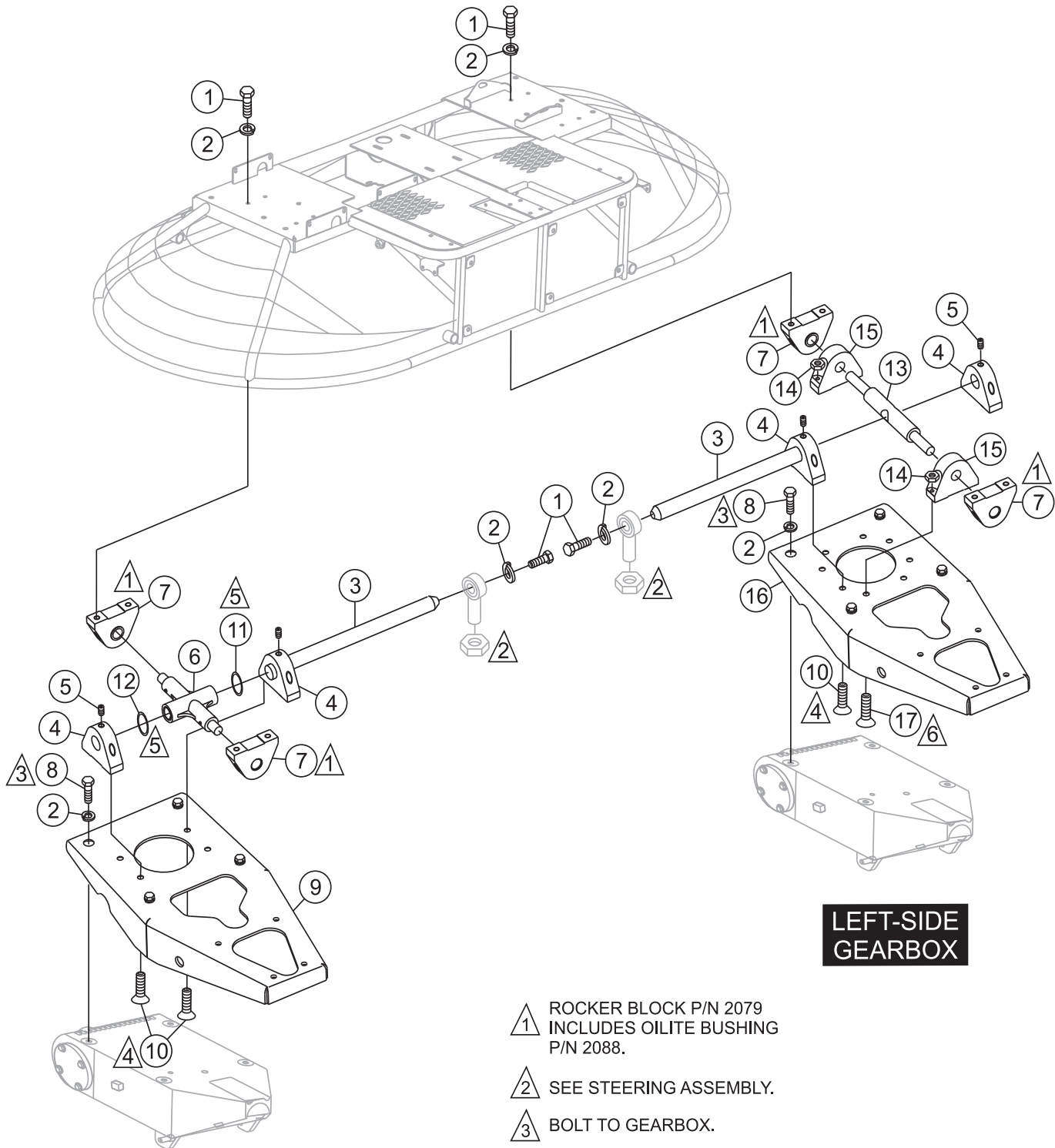
## JWN-SERIES — NAMEPLATE AND DECALS

### NAMEPLATE AND DECALS

<u>NO.</u>	<u>PART NO.</u>	<u>PART NAME</u>	<u>QTY.</u>	<u>REMARKS</u>
1	11246	DECAL SET, INTERNATIONAL STDS	1	
2	13118	DECAL, POWDER COATED	1	
3	10818	DECAL, MQ-WHITEMAN 24 X 3	1	
4	2300	DECAL, AL PITCH RH	1	
5	2332	DECAL, AL PITCH LH	1	
6	2634	DECAL, SPRING SAFETY	2	
7	1499	DECAL, MQ-WHITEMAN RED/TOWER	2	
8	11247	DECAL, SAFETY CLOTHING	1	
9	2814	DECAL, CONTROL PANEL	1	
10	20204	DECAL, JWN SERIES	1	

# JWN-SERIES — PIVOT ASSY. (RIGHT/LEFT)

## PIVOT ASSY. (RIGHT/LEFT)



**RIGHT-SIDE  
GEARBOX**

**LEFT-SIDE  
GEARBOX**

- ▲ 1 ROCKER BLOCK P/N 2079  
INCLUDES OILITE BUSHING  
P/N 2088.
- ▲ 2 SEE STEERING ASSEMBLY.
- ▲ 3 BOLT TO GEARBOX.
- ▲ 4 1" BOLTS P/N 1394 MATE TO  
PILLOW BLOCKS.
- ▲ 5 USE SHIMS AS NEEDED TO  
MINIMIZE LATERAL MOVEMENT  
OF PIVOT ARMS.
- ▲ 6 1-3/4" BOLTS P/N 1481 MATE TO  
NUTS.

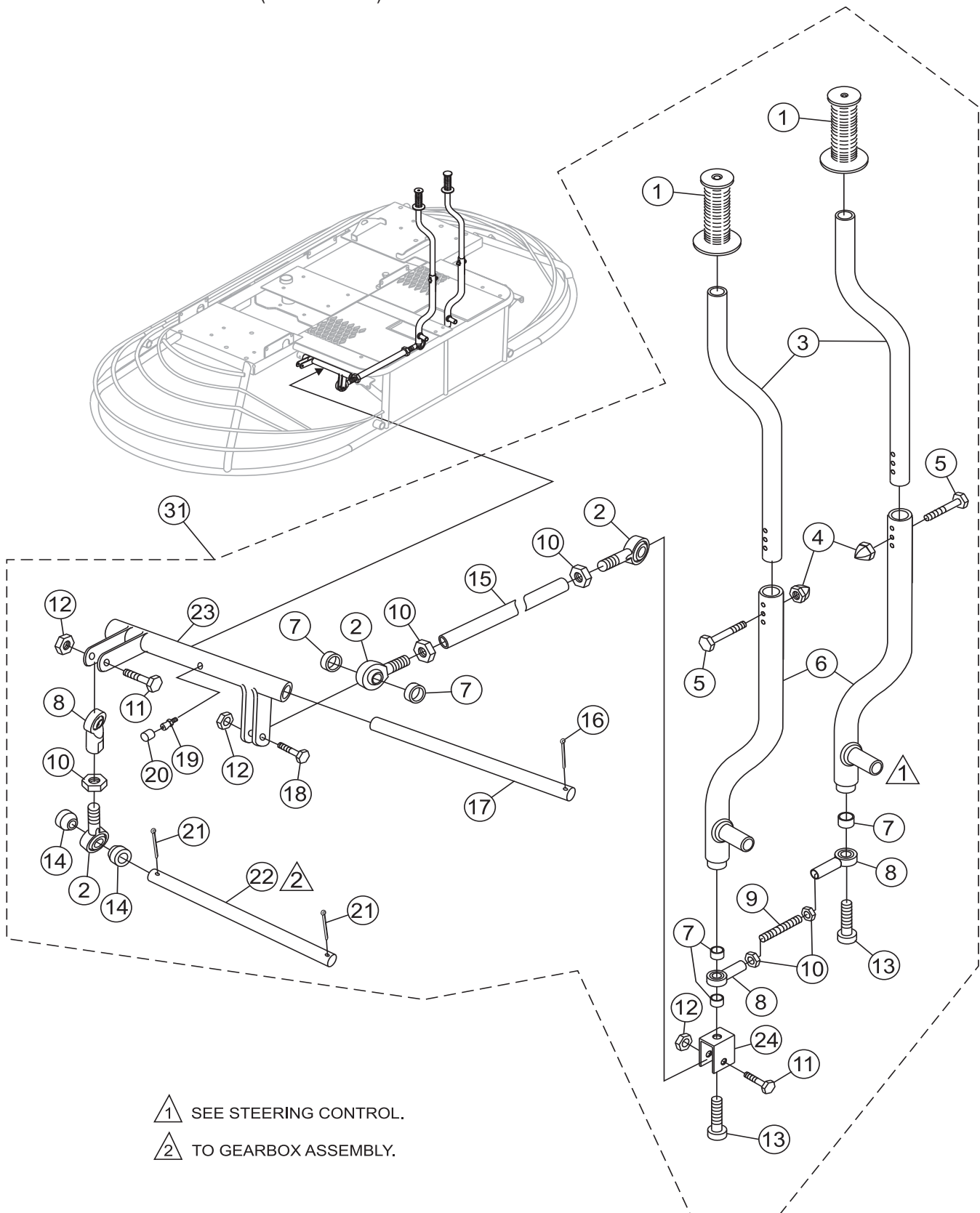
## JWN-SERIES— PIVOT ASSY. (RIGHT/LEFT)

### PIVOT ASSY. (RIGHT/LEFT)

<u>NO.</u>	<u>PART NO.</u>	<u>PART NAME</u>	<u>QTY.</u>	<u>REMARKS</u>
1	1023	SCREW, HHC 3/8- 16 X 1-1/4	10	
2	0166A	WASHER, LOCK, 3/8 MED.	18	
3	2824	BAR, 1" CONTROL PIVOT	2	
4	20040	ROCKER BLOCK, 1.0 HOLE	4	
5	10138	SCREW, SHS 5/16- 18 X 5/16	4	
6	2044	ARM, PIVOT RIGHT HAND	1	
7	2079	ROCKER BLOCK WITH BUSHING	4	
8	4196	SCREW, HHC 3/8- 16 X 3/4	8	
9	20011	PLATE, GEARBOX ADAPTOR, RIGHT	1	
10	1394	SCREW, FHSC 3/8- 16 X 1	8	
11	11772	SHIM TRUNNION .062 THK .....	1	USE AS NEEDED
12	11773	SHIM, TRUNNION .031 THK .....	1	USE AS NEEDED
13	2076	PIVOT TUBE	1	
14	10133	NUT, NYLOC 3/8- 16	4	
15	10973	ROCKER BLOCK	2	
16	20004	PLATE, GEARBOX ADAPTOR, LEFT	1	
17	1481	SCREW, FHSC 3/8- 16 X 1- 3/4	4	

# JWN-SERIES — STEERING HANDLES ASSY. (LEFT/RIGHT)

## STEERING HANDLES ASSY (LEFT/RIGHT)



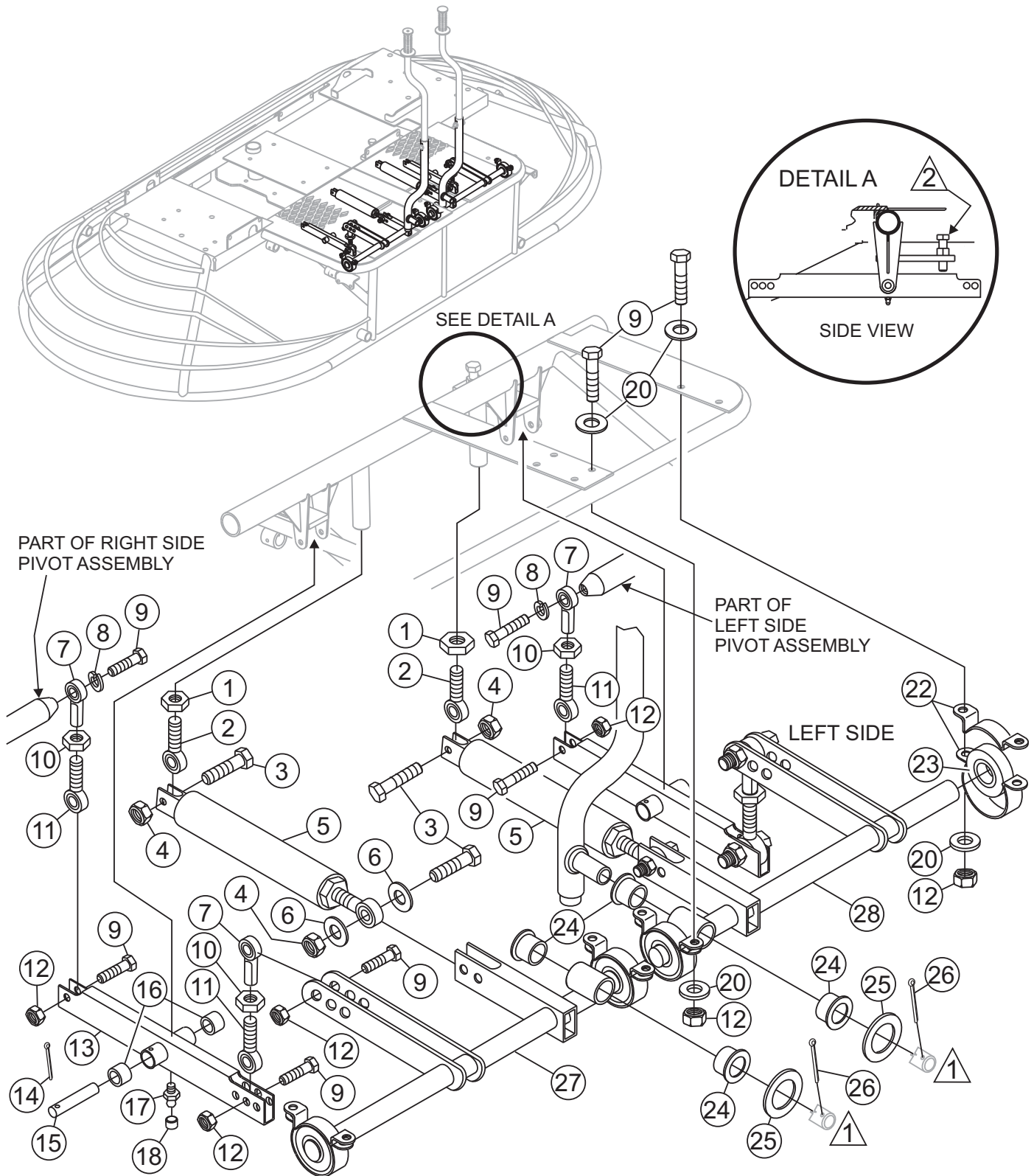
# JWN-SERIES — STEERING HANDLES ASSY. (LEFT/RIGHT)

## STEERING HANDLES ASSY (LEFT/RIGHT)

<u>NO.</u>	<u>PART NO.</u>	<u>PART NAME</u>	<u>QTY.</u>	<u>REMARKS</u>
1*	0189	GRIP, HANDLE	2	
2*	2063	ROD END, 3/8-24 MALE RH	3	
3*	10130-1	HANDLE, TUBE	2	
4*	2197	NUT, ACORN, 1/4-20	2	
5*	0424	SCREW HHC 1/4-20 X 1-1/4	2	
6*	11079-1	HANDLE, STEERING, LOWER	2	
7*	2196	SPACER, 1/2 X .402 X 1/4L	3	
8*	2064	ROD END, 3/8-24 FEMALE RH	2	
9*	11498	THREADPIECE, 3/8-24 X 4	1	
10*	2199	NUT, HEX JAM 3/8-24	5	
11*	1284	SCREW, HHC 3/8-16 X 1-1/2	2	
12*	10133	NUT, NYLOC 3/8-16	2	
13*	11089	SCREW, SHC 3/8-16 X 2 PLTD	2	
14*	2188	SPACER, 3/4 X 25/64 X .800L	2	
15*	11513	ROD, 9 1/2 L/R LINKAGE	1	
16*	2219	PIN, COTTER 1/8 X 1-1/2	1	
17*	11497	SHAFT, L/R MOTION LEVER	1	
18*	1665	SCREW, HHC 3/8-16 X 2	1	
19*	5228	ZERK, GREASE 45, 1/4-28 LONG	1	
20*	1162A	CAP, GREASE ZERK #2 YELLOW	1	
21*	0183	PIN, COTTER 1/8 X 1-1/4	2	
22*	3550	PIN, 3/8 DIA X 5 7/8 LONG	1	
23*	11441	MOTION CONTROL, RIGHT/LEFT	1	
24*	11303	BRACKET, L/R MOTION ROD	1	
31	7798-1	STEERING ASM, W/BEARINGS .....	1	INCLUDES ITEMS W/*

# JWN-SERIES — STEERING CONTROL ASSY. (LEFT/RIGHT)

STEERING CONTROL ASSY. (LEFT/RIGHT)



RIGHT SIDE

▲ 1 STEERING HANDLES. SEE PAGE 48.

▲ 2 ADJUST STEERING STOP SCREWS TO LIMIT TRAVEL PREVENTING CV JOINT FROM BOTTOMING.



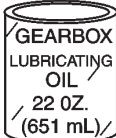
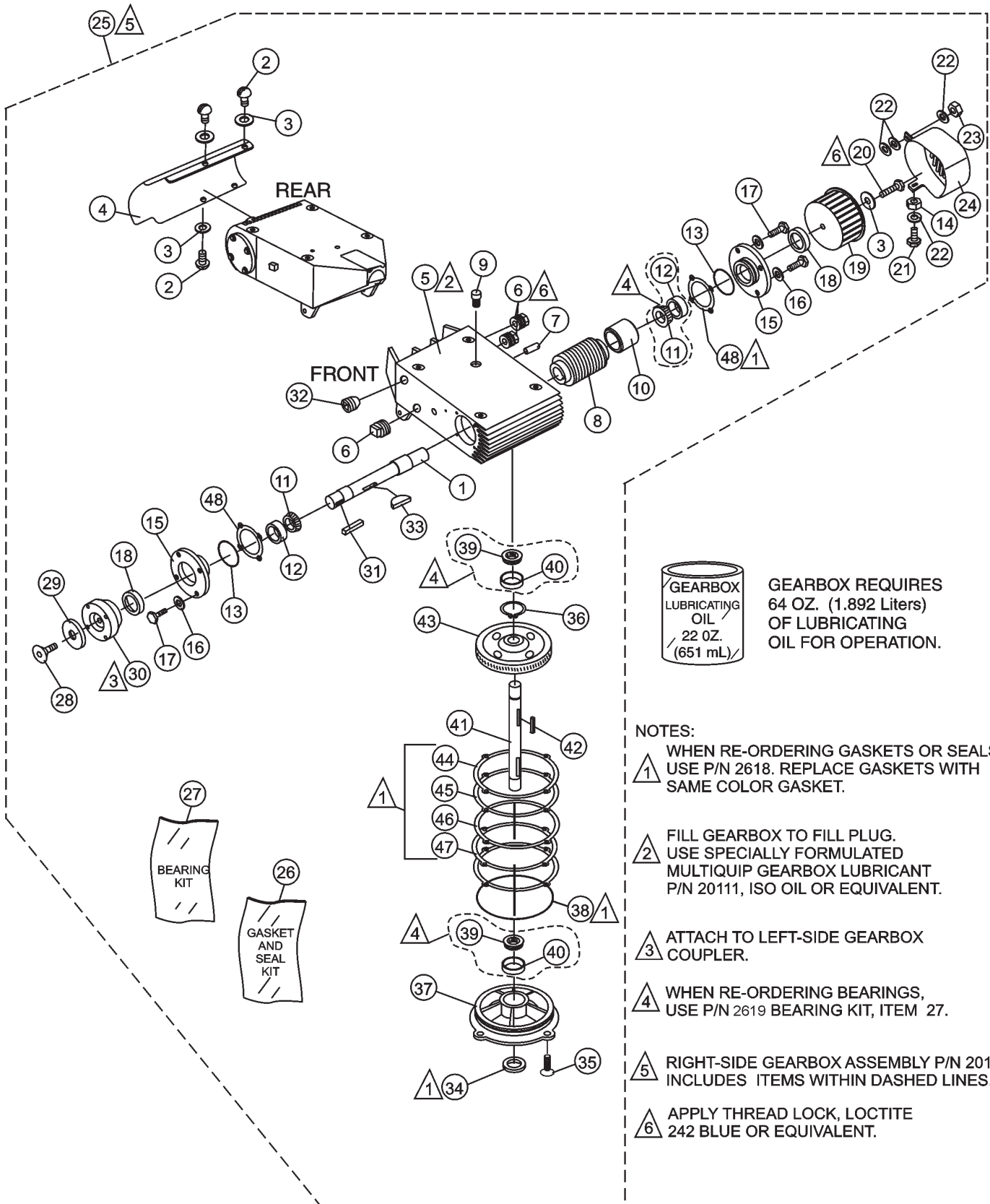
## JWN-SERIES — STEERING CONTROL ASSY. (LEFT/RIGHT)

### STEERING CONTROL ASSY. (LEFT/RIGHT)

<u>NO.</u>	<u>PART NO.</u>	<u>PART NAME</u>	<u>QTY.</u>	<u>REMARKS</u>
1	11146	NUT, HEX JAM 1/2-20 PLTD	2	
2	11142	ROD END, 1/2-20 MALE RH	2	
3	EM963105	SCREW, HHC 1/-13 X 2.....	4.....	REPLACES P/N 6159A
4	10176	NUT, NYLOC 1/2-13	4	
5	12625	ASSIST ASSEMBLY, STEERING	2	
6	0447	WASHER, FLAT 1/2 SAE	4	
7	2064	ROD END, 3/8-24 FEMALE RH	4	
8	0166A	WASHER, LOCK 3/8 MED	2	
9	1023	SCREW, HHC 3/8-16 X 1-1/4	16	
10	2199	NUT, HEX JAM 3/8-24	4	
11	2063	ROD END, 3/8-24 MALE RH	4	
12	10133	NUT, NYLOC 3/8-16	6	
13	11071	LEVER, STEERING CONTROL	2	
14	6014B	PIN, COTTER 3/32 X 1	2	
15	11275	PIN, 3/8 X 3 DIA CHN 100-2	2	
16	11072	BEARING, TORRINGTON JT69	4	
17	5228	ZERK, GREASE 45, 1/4-28 LONG	2	
18	1162A	CAP, GREASE ZERK #2 YELLOW	2	
20	10136	WASHER, FLAT 3/8 SAE	16	
22	11138	BEARING, HSG P-BLOCK 47MPB (2PC)	4	
23	11149	BEARING, SB-204-12	4	
24	12408	BUSHING, GARLOCK 12FDU12	4	
25	11265	WASHER, STEERING HANDLE	2	
26	2219	PIN, COTTER 1/8 X 1-1/2	2	
27	12651	STEERING CONTROL RS ASSIST	1	
28	12650	STEERING CONTROL LS ASSIST	1	

# JWN-SERIES — GEARBOX ASSY (RIGHT)

GEARBOX ASSY. (RIGHT)



GEARBOX REQUIRES  
64 OZ. (1.892 Liters)  
OF LUBRICATING  
OIL FOR OPERATION.

- NOTES:
- ① WHEN RE-ORDERING GASKETS OR SEALS USE P/N 2618. REPLACE GASKETS WITH SAME COLOR GASKET.
  - ② FILL GEARBOX TO FILL PLUG. USE SPECIALLY FORMULATED MULTIQUIP GEARBOX LUBRICANT P/N 20111, ISO OIL OR EQUIVALENT.
  - ③ ATTACH TO LEFT-SIDE GEARBOX COUPLER.
  - ④ WHEN RE-ORDERING BEARINGS, USE P/N 2619 BEARING KIT, ITEM 27.
  - ⑤ RIGHT-SIDE GEARBOX ASSEMBLY P/N 20134 INCLUDES ITEMS WITHIN DASHED LINES.
  - ⑥ APPLY THREAD LOCK, LOCTITE 242 BLUE OR EQUIVALENT.

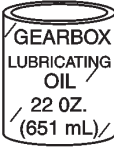
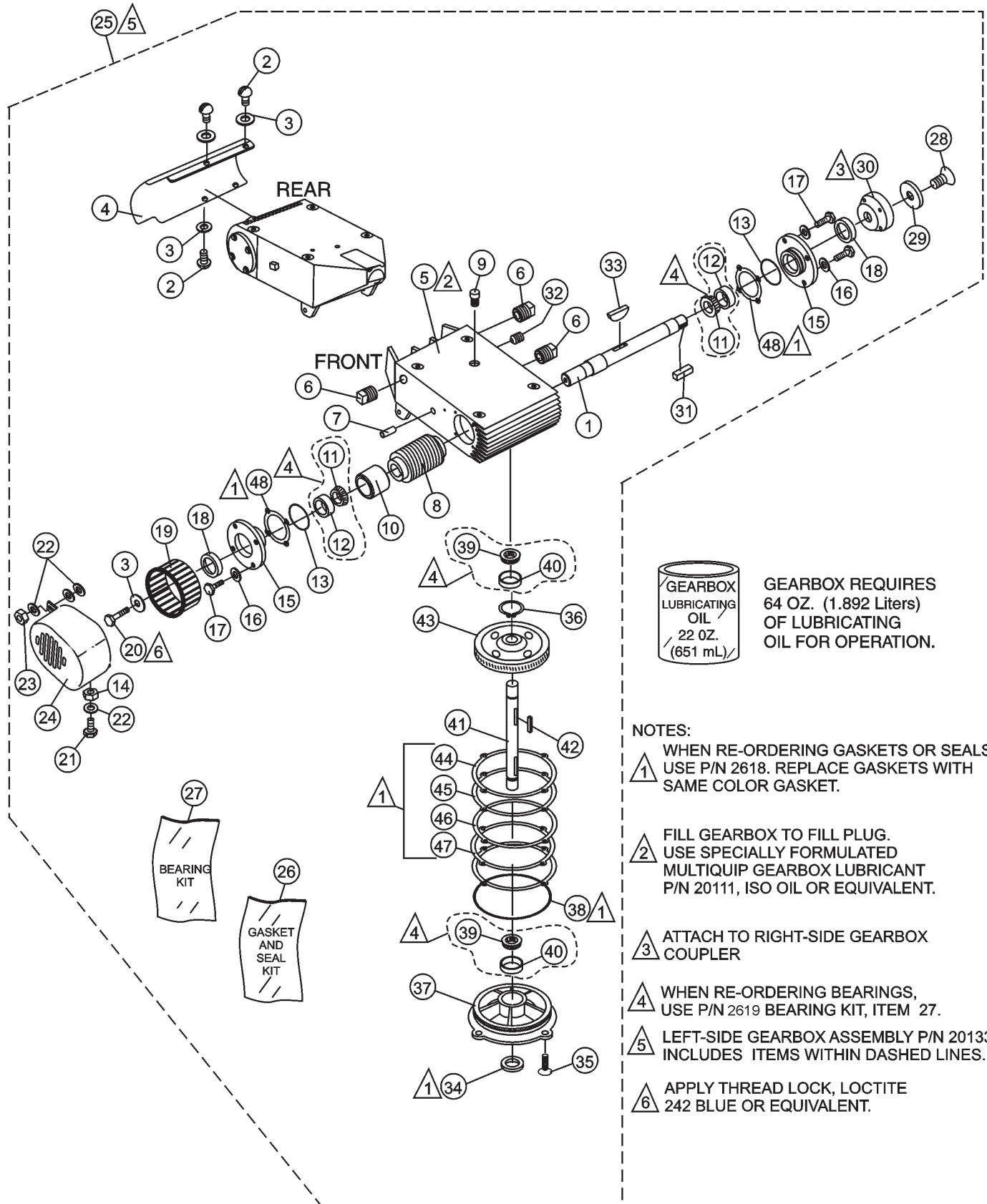
# JWN-SERIES — GEARBOX ASSY (RIGHT)

## GEARBOX ASSY. (RIGHT)

<u>NO.</u>	<u>PART NO.</u>	<u>PART NAME</u>	<u>QTY.</u>	<u>REMARKS</u>
1%	20065	SHAFT, GEARBOX INPUT W/FAN	1	
2%	5031A	SCREW, RHM 1/4- 20 X 1/2	4	
3%	0948	WASHER, FLAT, 1/4 SAE	5	
4%	12981	SHROUD, GB FIN COVER, RIGHT	1	
5%	20353	GEAR BOX 1-1/8 SHAFT	1	
6%	0121A	FITTING, PLUG 3/8MP SQUARE HEAD	3	
7%	10989	STUD, N10- 32 X 3/4	1	
8%	12908	RIGHT HAND WORM	1	
9%	1132	VENT, AIR	1	
10%	12583	SPACER, X 11D X 1.168L	1	
11%	9045	BEARING, CONE TIMKEN #1986	1	
12%	0232A	BEARING, CUP, TIMKEN #1932	1	
13%	2309	O-RING, 2-13/16" VINTON	1	
14%	0937	NUT, HEX #10- 32	1	
15%	2307	FLANGE, COUNTERSHAFT	1	
16%	10031	WASHER, EXT SHKP 1/4	8	
17%	2295	SCREW, HHC 1/4- 20 X 7/8	8	
18%	12909	SEAL, OIL, NATIONAL #471689V	1	
19%	10921	FAN, RIGHT SIDE	1	
20%	0424	SCREW, HHC 1/4- 20 X 1-1/4	1	
21%	19477	SCREW, HHC, WASHER 10- 32 X 1/2	1	
22%	2203	WASHER, FLAT #10 SAE	5	
23%	10019	NUT, NYLOC 10- 32	1	
24%	10894	RIGHT SIDE FAN COVER	1	
25%	20134	GEARBOX ASSY., RS W/FAN .....	1	INCLUDES ITEMS W/%
26%	2618	GASKET AND SEAL KIT .....	1	INCLUDES ITEMS W/#
27%	2619	BEARING KIT .....	1	INCLUDES ITEMS W/+
28%	1313	SCREW, FHSC 3/8- 24 X 3/4 PLAIN	1	
29%	9120	RETAINER, DRIVEN PULLEY	1	
30%	2048	COUPLER- 7/8" ID	1	
31%	2323	KEY, 1/4 X 1/4 X 13/16	1	
32%	10450	SCREW, SHS 10- 32 X 1/4	1	
33%	1139	KEY, WOODRUFF #21 HARDENED	1	
34%	9041	SEAL, 1-1/8 DIA NAT # 471763V	1	
35%	1146	SCREW, FHS 5/16- 18 X 1 NYLOC	4	
36%	1138	RING, SNAP TRUARC #5100- 112	1	
37%	9036	COVER, GEARBOX 1-1/8 SHAFT	1	
38%	9038	O-RING, A- 264 VITON	1	
39%	0232	BEARING, CONE TIMKEN #15126	2	
40%	0232A	BEARING, CUP, TIMKEN #1932	2	
41%	20013	SHAFT, OUTPUT HD GEARBOX	1	
42%	9180	KEY, 5/16 X 2-1/4 HRDND	1	
43%	9181	GEAR, WORM RH. HD	1	
44%		GASKET, RED .....	1	SOLD AS KIT ONLY
45%		GASKET, GREEN .....	1	SOLD AS KIT ONLY
46%		GASKET, BLUE .....	1	SOLD AS KIT ONLY
47%		GASKET, BROWN .....	1	SOLD AS KIT ONLY
48%		GASKET, YELLOW .....	1	SOLD AS KIT ONLY
49	20111	OIL, MOBIL SHC 634 ISO VG640	64 OZ	

# JWN-SERIES — GEARBOX ASSY. (LEFT)

## GEARBOX ASSY. (LEFT)



GEARBOX REQUIRES  
64 OZ. (1.892 Liters)  
OF LUBRICATING  
OIL FOR OPERATION.

**NOTES:**

- 1 WHEN RE-ORDERING GASKETS OR SEALS USE P/N 2618. REPLACE GASKETS WITH SAME COLOR GASKET.
- 2 FILL GEARBOX TO FILL PLUG. USE SPECIALLY FORMULATED MULTIQUIP GEARBOX LUBRICANT P/N 20111, ISO OIL OR EQUIVALENT.
- 3 ATTACH TO RIGHT-SIDE GEARBOX COUPLER
- 4 WHEN RE-ORDERING BEARINGS, USE P/N 2619 BEARING KIT, ITEM 27.
- 5 LEFT-SIDE GEARBOX ASSEMBLY P/N 20133 INCLUDES ITEMS WITHIN DASHED LINES.
- 6 APPLY THREAD LOCK, LOCTITE 242 BLUE OR EQUIVALENT.

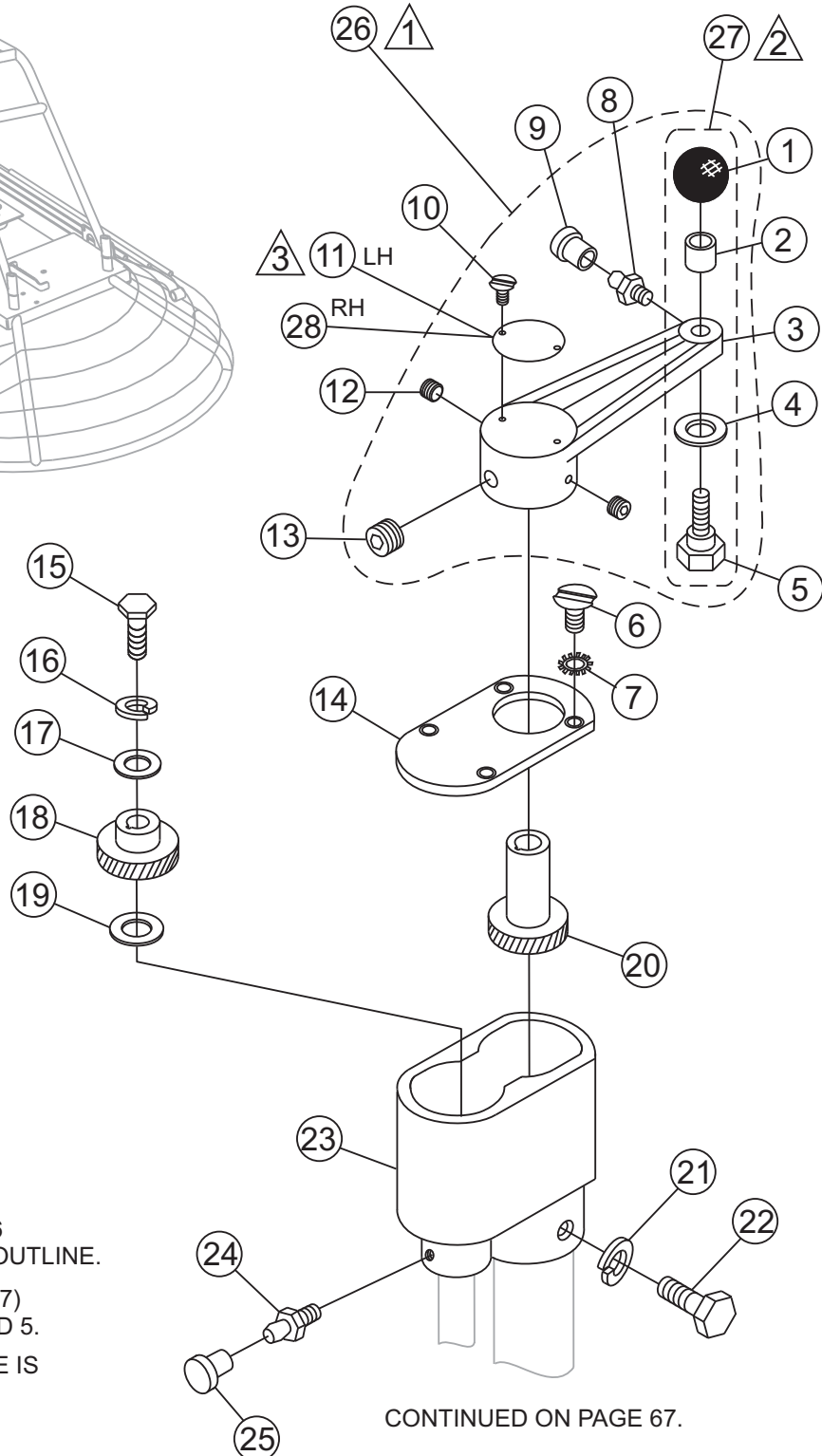
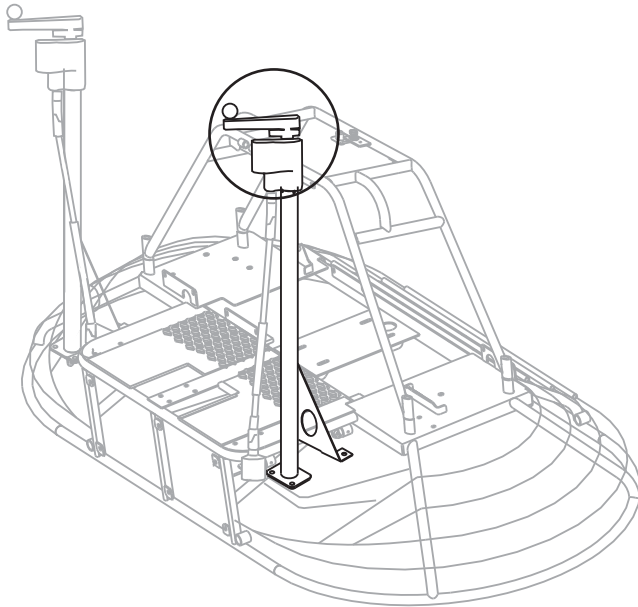
# JWN-SERIES — GEARBOX ASSY. (LEFT)

## GEARBOX ASSY. (LEFT)

<u>NO.</u>	<u>PART NO.</u>	<u>PART NAME</u>	<u>QTY.</u>	<u>REMARKS</u>
1%	20065	SHAFT, GEARBOX INPUT W/FAN	1	
2%	5031A	SCREW, RHM 1/4- 20 X 1/2	4	
3%	0948	WASHER, FLAT, 1/4 SAE	5	
4%	12982	SHROUD, GB FIN COVER, LEFT	1	
5%	20353	GEAR BOX 1-1/8 SHAFT	1	
6%	0121A	FITTING, PLUG 3/8MP SQUARE HEAD	3	
7%	10989	STUD, N10- 32 X 3/4	1	
8%	12907	LEFT HAND WORM	1	
9%	1132	VENT, AIR	1	
10%	12583	SPACER, X 11D X 1.168L	1	
11%+	9045	BEARING, CONE TIMKEN #1986	1	
12%+	0232A	BEARING, CUP, TIMKEN #1932	1	
13%#	2309	O-RING, 2-13/16" VINTON	1	
14%	0937	NUT, HEX #10- 32	1	
15%	2307	FLANGE, COUNTERSHAFT	1	
16%	10031	WASHER, EXT SHKP 1/4	4	
17%	2295	SCREW, HHC 1/4- 20 X 7/8	4	
18%	12909	SEAL, OIL, NATIONAL #471689V	1	
19%	10922	FAN, LEFT SIDE	1	
20%	0424	SCREW, HHC 1/4- 20 X 1-1/4	1	
21%	19477	SCREW, HHC, WASHER 10- 32 X 1/2	1	
22%	2203	WASHER, FLAT #10 SAE	5	
23%	10019	NUT, NYLOC 10- 32	1	
24%	10893	LEFT SIDE FAN COVER	1	
25	20133	GEARBOX ASSY., LS W/FAN.....	1	INCLUDES ITEMS W/%
26%	2618	GASKET AND SEAL KIT .....	1	INCLUDES ITEMS W/#
27%	2619	BEARING KIT .....	1	INCLUDES ITEMS W/+
28%	1313	SCREW, FHSC 3/8- 24 X 3/4 PLAIN	1	
29%	9120	RETAINER, DRIVEN PULLEY	1	
30%	2048	COUPLER- 7/8" ID	1	
31%	2323	KEY, 1/4 X 1/4 X 13/16	1	
32%	10450	SCREW, SHS 10- 32 X 1/4	1	
33%	1139	KEY, WOODRUFF #21 HARDENED	1	
34%#	9041	SEAL, 1-1/8 DIA NAT # 471763V	1	
35%	1146	SCREW, FHS 5/16- 18 X 1 NYLOC	4	
36%	1138	RING, SNAP TRUARC #5100- 112	1	
37%	9036	COVER, GEARBOX 1-1/8 SHAFT	1	
38%#	9038	O-RING, A-264 VITON	1	
39%+	0232	BEARING, CONE TIMKEN #15126	2	
40%+	0232A	BEARING, CUP, TIMKEN #1932	2	
41%	20013	SHAFT, OUTPUT HD GEARBOX	1	
42%	9180	KEY, 5/16 X 2-1/4 HRDND	1	
43%	2001	GEAR, WORM LH. HD	1	
44%#		GASKET, RED .....	1	SOLD AS KIT ONLY
45%#		GASKET, GREEN .....	1	SOLD AS KIT ONLY
46%#		GASKET, BLUE .....	1	SOLD AS KIT ONLY
47%#		GASKET, BROWN .....	1	SOLD AS KIT ONLY
48%#		GASKET, YELLOW .....	2	SOLD AS KIT ONLY
49	20111	OIL, MOBIL SHC 634 ISO VG640	64 OZ	

# JWN-SERIES — TWIN PITCH HANDLE ASSY. (LEFT/RIGHT)

## TWIN PITCH HANDLE ASSY. (LEFT/RIGHT)



▲ 1 LEVER ASSEMBLY, ITEM 26  
INCLUDES ITEMS WITHIN OUTLINE.

▲ 2 KNOB KIT P/N 2737 (ITEM 27)  
INCLUDES ITEMS 1,2,4, AND 5.

▲ 3 RIGHT SIDE PITCH HANDLE IS  
IDENTICAL TO LEFT SIDE  
PITCH HANDLE UNLESS  
OTHERWISE NOTED.

CONTINUED ON PAGE 67.

# JWN-SERIES — TWIN PITCH HANDLE ASSY. (LEFT/RIGHT)

## TWIN PITCH HANDLE ASSY. (LEFT/RIGHT)

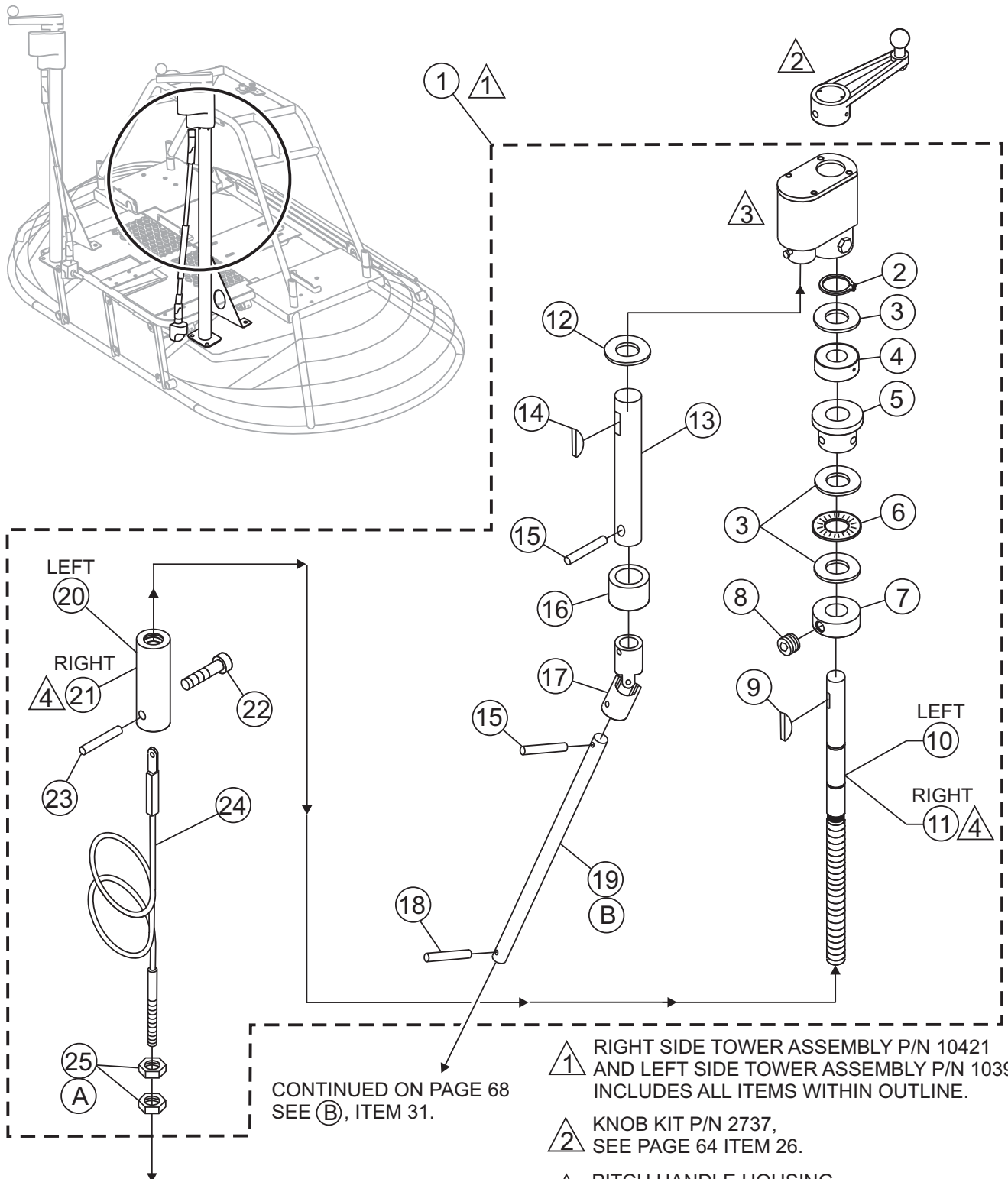
<u>NO</u>	<u>PART NO</u>	<u>PART NAME</u>	<u>QTY.</u>	<u>REMARKS</u>
1 #	4403	CRANK KNOB	1	
2 #	3231	SPACER	1	
3 #	1615	CRANK LEVER	1	
4 #	1733	HARDENED WASHER	1	
5 #	1616	SHOULDER BOLT	1	
6 +%	2620	SCREW, BHC 10 – 24 X 5/8	4	
7	10114	WASHER, EXT. SHKP, #8	4	
8	2621	FITTING GREASE	1	
9	1162A	CAP, GREASE ZERK/2	1	
10 #	4014	SCREW, 2-3/16 P-K TYPE U DRIVE	2	
11	2300	DECAL, AL PITCH, RH	1	
12 #	1528	SCREW, SHSS 1/4 – 20 X 5/16"	2	
13 #	0185	SCREW, SHSS 3/8 – 16 X 3/8"	1	
14 +%	2649	COVER, PITCH CONT HOUSING	1	
15 +%	1579	SCREW, HHC 1/4 – 20 X 1/2	1	
16 +%	0181 B	WASHER, LOCK, 1/4 MED	4	
17 +%	0948	WASHER, FLAT, 1/4 SAE	1	
18 +%	1530	GEAR, SLAVE, TPC	1	
19 +%	1733	WASHER, 1/32 X 1/2 HARDENED	8	
20 +%	1529	GEAR, MASTER, TPC	1	
21 +%	0161C	WASHER, LOCK 5/16 MED	1	
22 +%	0655	SCREW, HHC 5/16 – 18 X 3/4	1	
23 +%	10546	HOUSING, PITCH CONTROL, 1-3/4	1	
24 +%	2621	ZERK, GREASE STR 1/4 – 28	1	
25 +%	1162 A	CAP, GREASE ZERK	1	
26	1617	LEVER ASSY. , TROWEL ADJUSTMENT ...	1	INCLUDES ITEMS W/#
27	2737	KNOB, KIT .....	1	INCLUDES ITEMS W/\$
28	2332	DECAL, AL PITCH, LH	1	

NOTE 1: ITEMS WITH % ARE PART OF TWIN PITCH ASSY. RIGHT SIDE  
 ITEMS WITH + ARE PART OF TWIN PITCH ASSY. LEFT SIDE

NOTE 2: INDICATED QUANTITIES ARE FOR ONE PITCH TOWER.  
 IF ORDERING FOR TWO PITCH TOWERS DOUBLE THE QUANTITY.

# JWN-SERIES — TWIN PITCH TOWER ASSY. (LEFT/RIGHT)

TWIN PITCH TOWER ASSY. (LEFT/RIGHT)



CONTINUED ON PAGE 68  
SEE (A), ITEM 32.

CONTINUED ON PAGE 68  
SEE (B), ITEM 31.

- ① RIGHT SIDE TOWER ASSEMBLY P/N 10421 AND LEFT SIDE TOWER ASSEMBLY P/N 10392 INCLUDES ALL ITEMS WITHIN OUTLINE.
- ② KNOB KIT P/N 2737, SEE PAGE 64 ITEM 26.
- ③ PITCH HANDLE HOUSING COMPONENTS, SEE PAGE 64.
- ④ RIGHT SIDE TWIN PITCH ASSEMBLY IS IDENTICAL TO LEFT SIDE TWIN PITCH ASSEMBLY UNLESS OTHERWISE NOTED.



# JWN-SERIES — TWIN PITCH TOWER ASSY. (LEFT/RIGHT)

## TWIN PITCH TOWER ASSY. (LEFT/RIGHT)

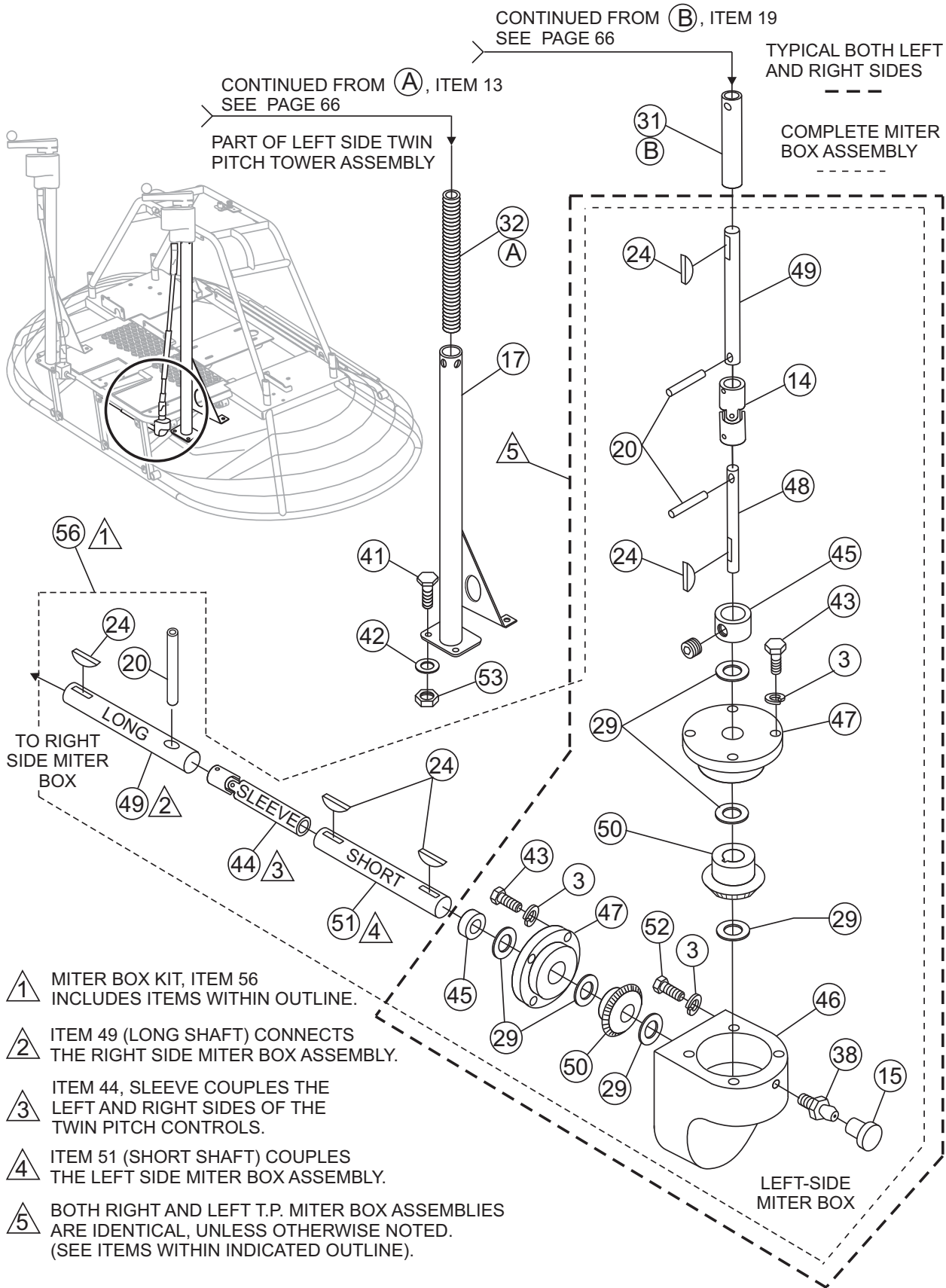
<u>NO</u>	<u>PART NO</u>	<u>PART NAME</u>	<u>QTY.</u>	<u>REMARKS</u>
1 (LT)	10392	TOWER ASSY. , LEFT TPC .....	1	.. INCLUDES ITEMS W/+
1 (RT)	10421	TOWER ASSY. , RIGHT TPC .....	1	.. INCLUDES ITEMS W/%
2 +%	10512	RING, SNAP, TRUARC 5160 – 75	1	
3 +%	2170	BEARING, RACE, TORR #TRA 1220	3	
4 +%	1604	BEARING, BALL	1	
5 +%	1612	BEARING, ALUM – PITCH CONTR	1	
6 +%	2169	BEARING, THRUST, TORR #NTA 1220	1	
7 +%	2367	SET COLLAR .....	1	.. INCLUDES ITEM 8
8 +%	0685	SCREW, SHS 5/16-18 X 5/16	1	
9 +%	0126 B	KEY, WOODRUFF #9	1	
10 +	2010	SHAFT, PITCH CONTROL, LH TPC .....	1	.. LEFT SIDE ONLY REPLACES 10511
11 %	10510	SHAFT, PITCH CONTROL, RH TPC .....	1	.. RIGHT SIDE ONLY
12 +%	1733	WASHER, 1/32 X 1/2 HARDENED	8	
13 +%	2007	SHAFT	1	
14 +%	1578	KEY, WOODRUFF, #3 .....	9	.. QTY. INCLUDES USAGE ON BOTH TWIN PITCH ASSEMBLIES, AND MITER BOX SHAFTS.
15 +%	11654	PIN, ROLL 1/8 X 1 PLATED .....	5	.. QTY. INCLUDES USAGE ON BOTH TWIN PITCH ASSEMBLIES, AND MITER BOX SHAFTS.
16 +%	2311	SPACER, 3/4 X 1/2 X 0.8L	1	
17 +%	1536	U-JOINT, PITCH CONTROL	1	
18 +%	1586	PIN, ROLL 1/8 X 3/4	1	
19 +%	2023	SHAFT, PITCH CONTROL	1	
20 +	10722	SLIDE BLOCK, LH PITCH CONTROL ....	1	.. LEFT SIDE ONLY
21 %	10721	SLIDE BLOCK, RH PITCH CONTROL ....	1	.. RIGHT SIDE ONLY
22 +%	10382	BOLT, SHOULDER 3/8 X 3/8 LONG	1	
23 +%	10723	PIN, SPIROL 3/16 X 1 3/8 HD	1	
24 +%	12460	CABLE, PITCH ASSY.	1	
25 +%	1116	NUT, BRASS JAM 5/16 – 18	2	

NOTE 1: ITEMS WITH % ARE PART OF TWIN PITCH ASSY. RIGHT SIDE  
 ITEMS WITH + ARE PART OF TWIN PITCH ASSY. LEFT SIDE

NOTE 2: INDICATED QUANTITIES ARE FOR ONE PITCH TOWER.  
 IF ORDERING FOR TWO PITCH TOWERS DOUBLE THE QUANTITY.

# JWN-SERIES—TWIN PITCH MITER BOX ASSY. (LEFT/RIGHT)

## TWIN PITCH MITER BOX ASSY. (LEFT/RIGHT)



# JWN-SERIES—TWIN PITCH MITER (LEFT/RIGHT)

## TWIN PITCH MITER BOX ASSY. (LEFT/RIGHT)

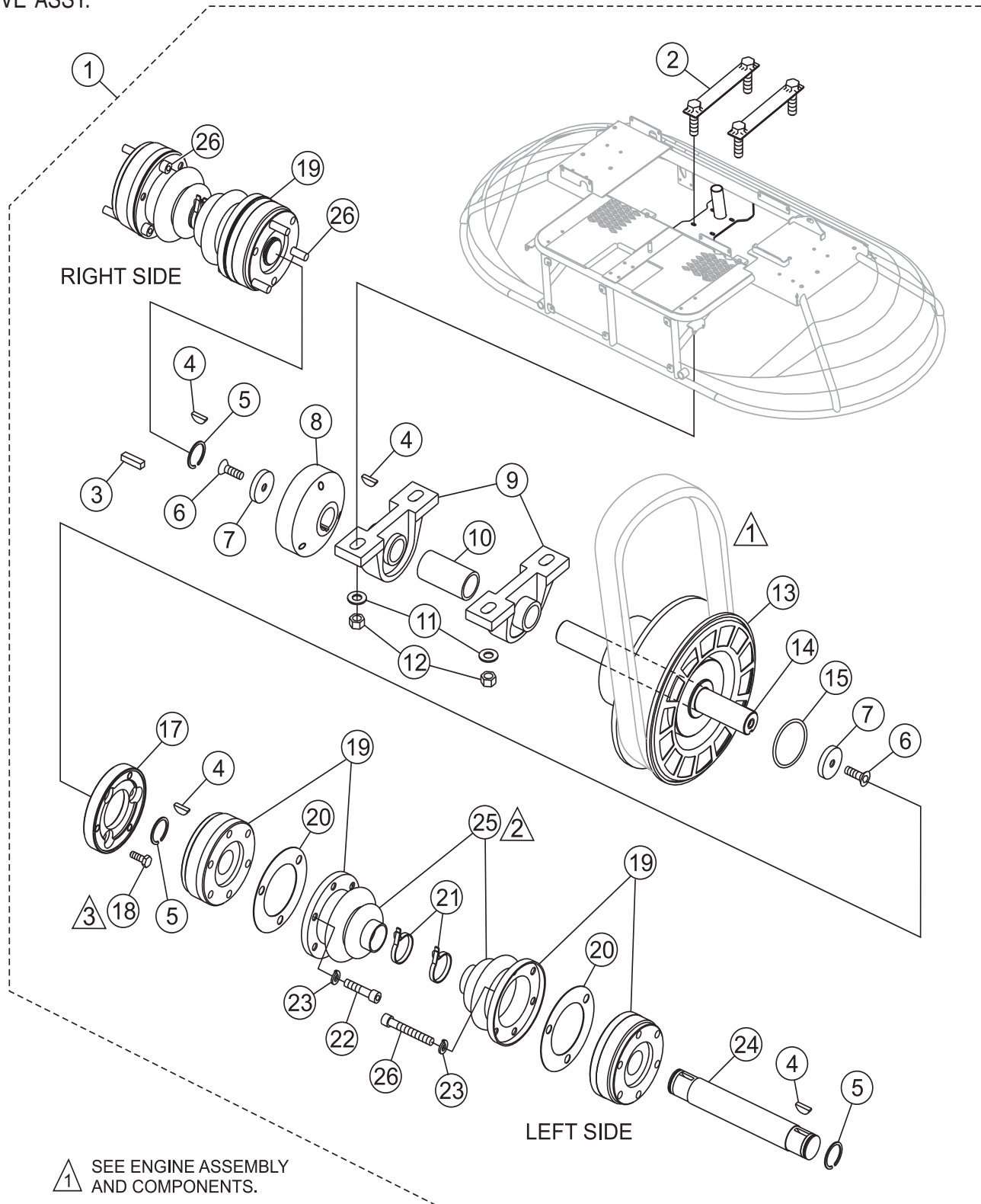
<u>NO.</u>	<u>PART NO.</u>	<u>PART NAME</u>	<u>QTY.</u>	<u>REMARKS</u>
3*+%	0181B	WASHER, LOCK 1/4 MED	20	
14*+%	1536	U-JOINT, PITCH CONTROL	2	
15*+%	1162 A	CAP, GREASE ZERK	2	
17	10548	TUBE, PITCH CONTROL	1	
20*+%	1586	PIN ROLL 1/8 x 3/4 .....	11 .....	QTY INCLUDES USAGE ON BOTH TWIN PITCH ASSEMBLIES, AND MITER BOX SHAFTS.
24*+%	1578	KEY, WOODRUFF, #3 .....	9 .....	QTY INCLUDES USAGE ON BOTH TWIN PITCH ASSEMBLIES, AND MITER BOX SHAFTS.
29*+%	1733	WASHER, 1/32 x 1/2 HARDEN	8	
31	2012	SLEEVE, ADJ.-LONG RIDER	1	
32	2156	SPRING, COIL	1	
38*+%	2621	ZERK, GREASE STR 1/4-28	2	
41	0202	SCREW, HHC 5/16-18 x 1	4	
42	0300 B	WASHER, FLAT 5/16 SAE	4	
43*	0730	SCREW, HHC 1/4-20 x 1	8	
44*	2104	SLEEVE W/U JOINT	1	
45*	1577	SET COLLAR, 1/2	2	
46*	1987	MITER BOX, PITCH CONTROL	1	
47*	1988	MITER BOX, BEARING CAP	2	
48*	2021	SHAFT, MITER VERTICAL	1	
49*	2022	SHAFT, MITER .....	3 .....	QTY INCLUDES USAGE ON BOTH TWIN PITCH ASSEMBLIES, AND MITER BOX SHAFTS.
50*	2062	GEAR, MITER	2	
51*	2821	SHAFT, MITER BOX HORIZ.	1	
52*	4514	SCREW, HHC 1/4-20 x 5/8	4	
53	5283	NUT, NYLOC 5/16-18	4	
56	11655	MITER BOX ASSEMBLY .....	1 .....	INCLUDES ITEMS W/*

NOTE 1: ITEMS WITH % ARE PART OF TWIN PITCH ASSY. RIGHT SIDE  
 ITEMS WITH + ARE PART OF TWIN PITCH ASSY. LEFT SIDE

NOTE 2: INDICATED QUANTITIES ARE FOR ONE PITCH TOWER.  
 IF ORDERING FOR TWO PITCH TOWERS DOUBLE THE QUANTITY.

# JWN-SERIES — DRIVE ASSY.

## DRIVE ASSY.



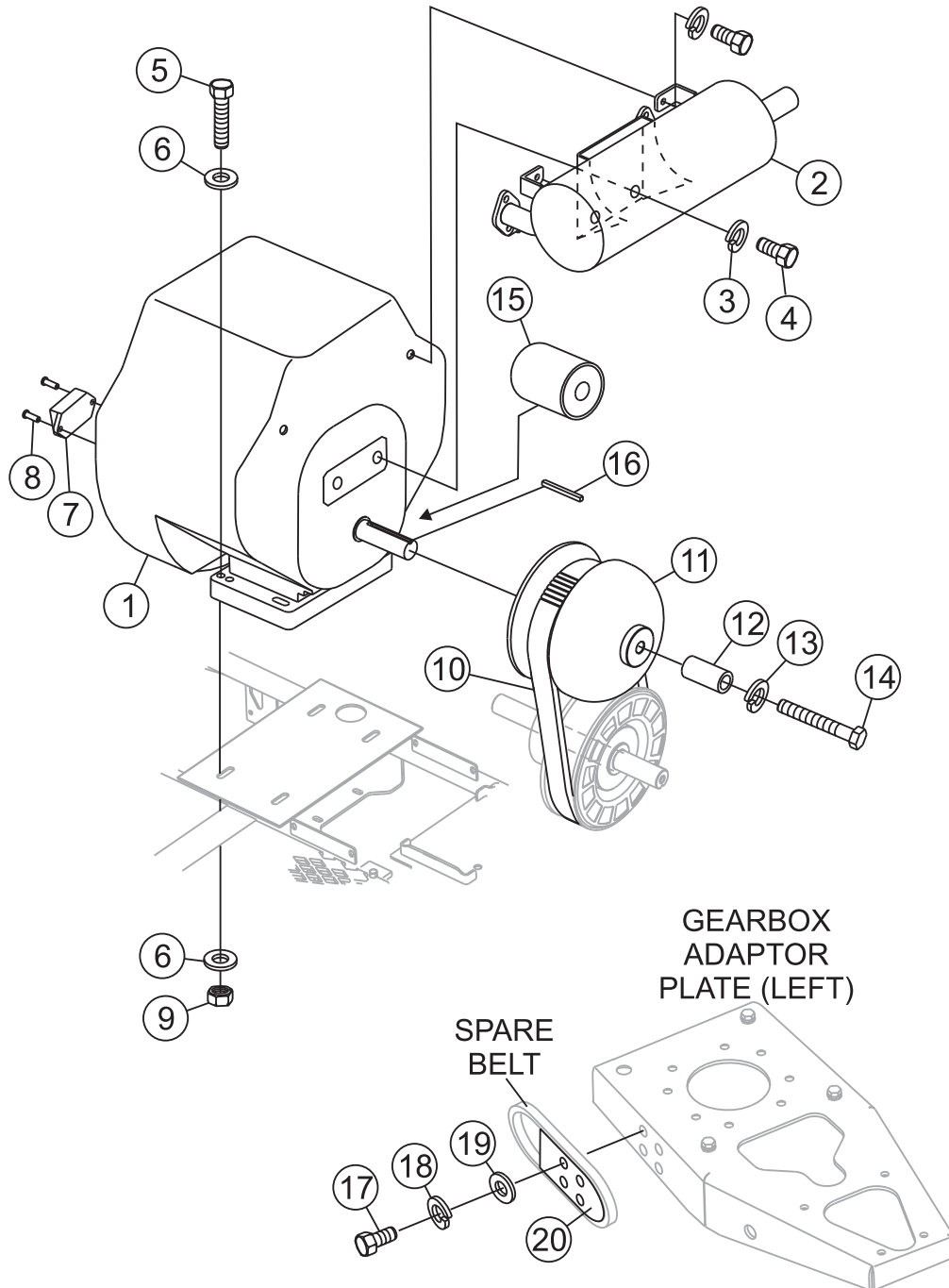
# JWN-SERIES — DRIVE ASSY.

## DRIVE ASSY.

<u>NO.</u>	<u>PART NO.</u>	<u>PART NAME</u>	<u>QTY.</u>	<u>REMARKS</u>
1	20077	DRIVE ASSEMBLY .....	1	INCLUDES ITEMS W/%
2%	20186	PLATE, BEARING MOUNT	2	
3%	10909	KEY, 3/16 X 11/16	1	
4%	0126	KEY, WOODRUFF #9	4	
5%	2090	RING, SNAP TRUARC #5100- 106	4	
6%	1146	SCREW, FHSC 5/16- 18 X 1 NYLOC	2	
7%	2037	WASHER, RETAINING	2	
8%	2029	COUPLER, 1 ID. RIDER	1	
9%	10337	BEARING, PILLOW BLOCK FAF YAK- 1	2	
10%	20076	SPACER, BEARING SHAFT	1	
11%	10136	WASHER, FLAT 3/8 SAE	4	
12%	10133	NUT, NYLOC 3/8- 16	4	
13%	20137	PULLEY, CVT LOWER COMET 302535C	1	
14%	20069	SHAFT, DRIVE BEARING	1	
15%	20116	O-RING, SIZE- 031 BUNA N	1	
17%	12590	COUPLER, CV JOINT COMET CLUTCH	1	
18%	20056	SCREW, HHC 1/4- 28 X 3/4 GRD. 8	3	
19%	2052	JOINT, CV W/BOOT .....	4	INCLUDES ITEMS W/*
20%	11108	GASKET, CV JOINT BOOT	4	
21%	1662	TIE WRAP, CABLE BLACK	4	
22%	0243	SCREW, SHC 5/16- 18 X 1-3/4	3	
23%	0161C	WASHER, LOCK, 5/16 MEDIUM	12	
24%	2071	SHAFT, CV JOINT, 7.44LG	2	
25%*	2259	BOOT, CV JOINT	4	
26%	2186	SCREW, SHC 5/16-18 X 2-1/4 PLTD	4	

# JWN-SERIES — MUFFLER/BELT ASSY.

MUFFLER/BELT ASSY.



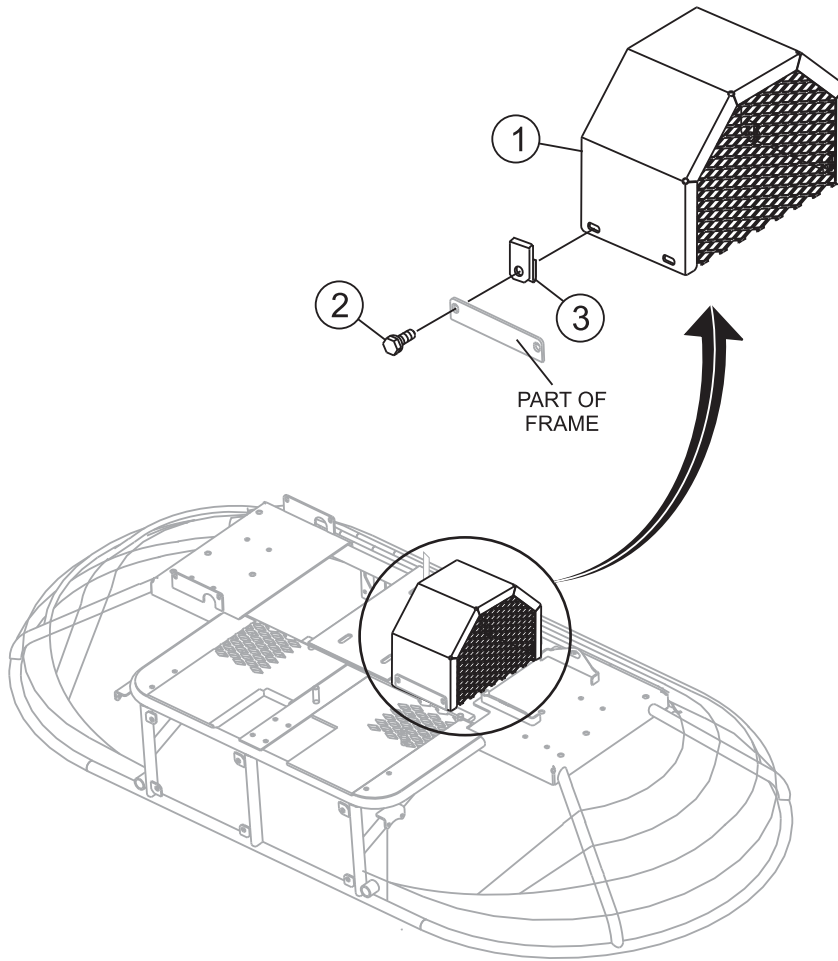
## JWN-SERIES — MUFFLER/BELT ASSY.

### MUFFLER/BELT ASSY.

<u>NO.</u>	<u>PART NO.</u>	<u>PART NAME</u>	<u>QTY.</u>	<u>REMARKS</u>
1	20216	ENGINE, HONDA 24 HP GX670	1	
2	20336	MUFFLER, 24 HONDA	1	
3	0160C	WASHER, LOCK 5/16 MEDIUM	4	
4	2299	SCREW, HHC M8-1.25 X 16MM	4	
5	0300A	SCREW, HHC 5/16-18 X 2	4	
6	19470	WASHER, FLAT 5/16 USS	8	
7	2655	HOURLY METER	1	
8	8239	RIVET, POP 1/8 DIA X .400 ALUMINUM	2	
9	5283	NUT, NYLOC 5/16-18	4	
10	20138	BELT, CVT COMET 302609 DF	1	
11	12877	CLUTCH, CVT - 1 1/9 COMET 302533C	1	
12	20265	SPACER, 1.250 DIA X .188 W X 2.3 LONG	1	
13	2955	WASHER, LOCK, 7/16 ZINC	1	
14	20264	SCREW, HHC 7/16-20 UNF X 3 1/2	1	
15	15410ZJ4999AH	FILTER, OIL	1	
16	300518C	KEY	1	
17	0131A	SCREW, HHC 1/4-20 X 3/4	4	
18	0181B	WASHER, LOCK, 1/4 MED	4	
19	0948	WASHER, FLAT 1/4 SAE	4	
20	2429	HOLDER, SPARE BELT	1	

# JWN-SERIES — BELTGUARD ASSY.

BELT GUARD ASSY.





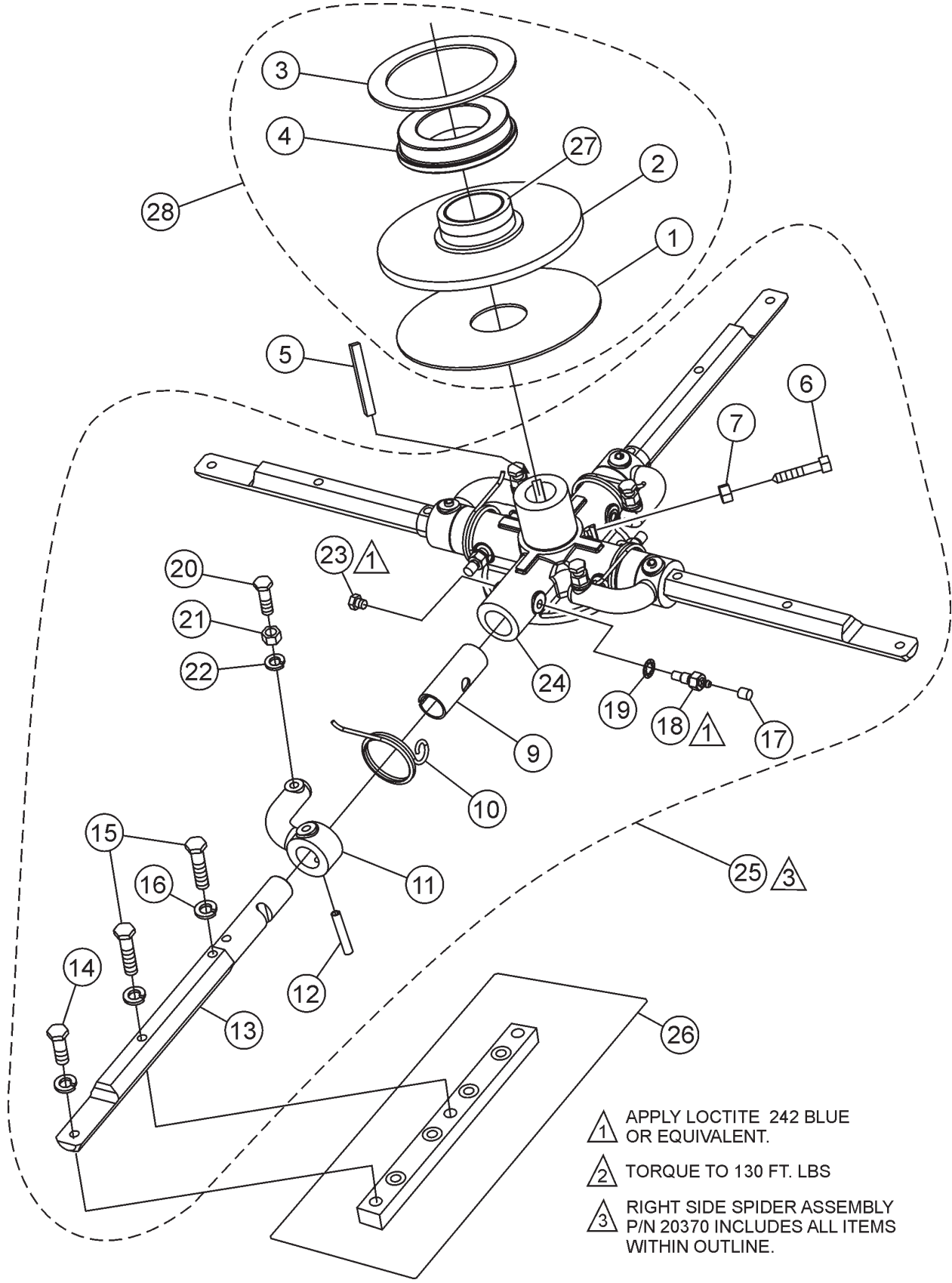
## JWN-SERIES — BELTGUARD ASSY.

BELT GUARD ASSY.

<u>NO.</u>	<u>PART NO.</u>	<u>PART NAME</u>	<u>QTY.</u>	<u>REMARKS</u>
1	20100	BELT GUARD	1	
2	11819	SCREW, HHC W/WASHER 1/4-20 X 3/4	4	
3	11534	NUT, U-TYPE 1/4-20	4	

# JWN-SERIES — SPIDER ASSY. (RIGHT)

## SPIDER ASSY. (RIGHT)



- ▲ 1 APPLY LOCTITE 242 BLUE OR EQUIVALENT.
- ▲ 2 TORQUE TO 130 FT. LBS
- ▲ 3 RIGHT SIDE SPIDER ASSEMBLY P/N 20370 INCLUDES ALL ITEMS WITHIN OUTLINE.

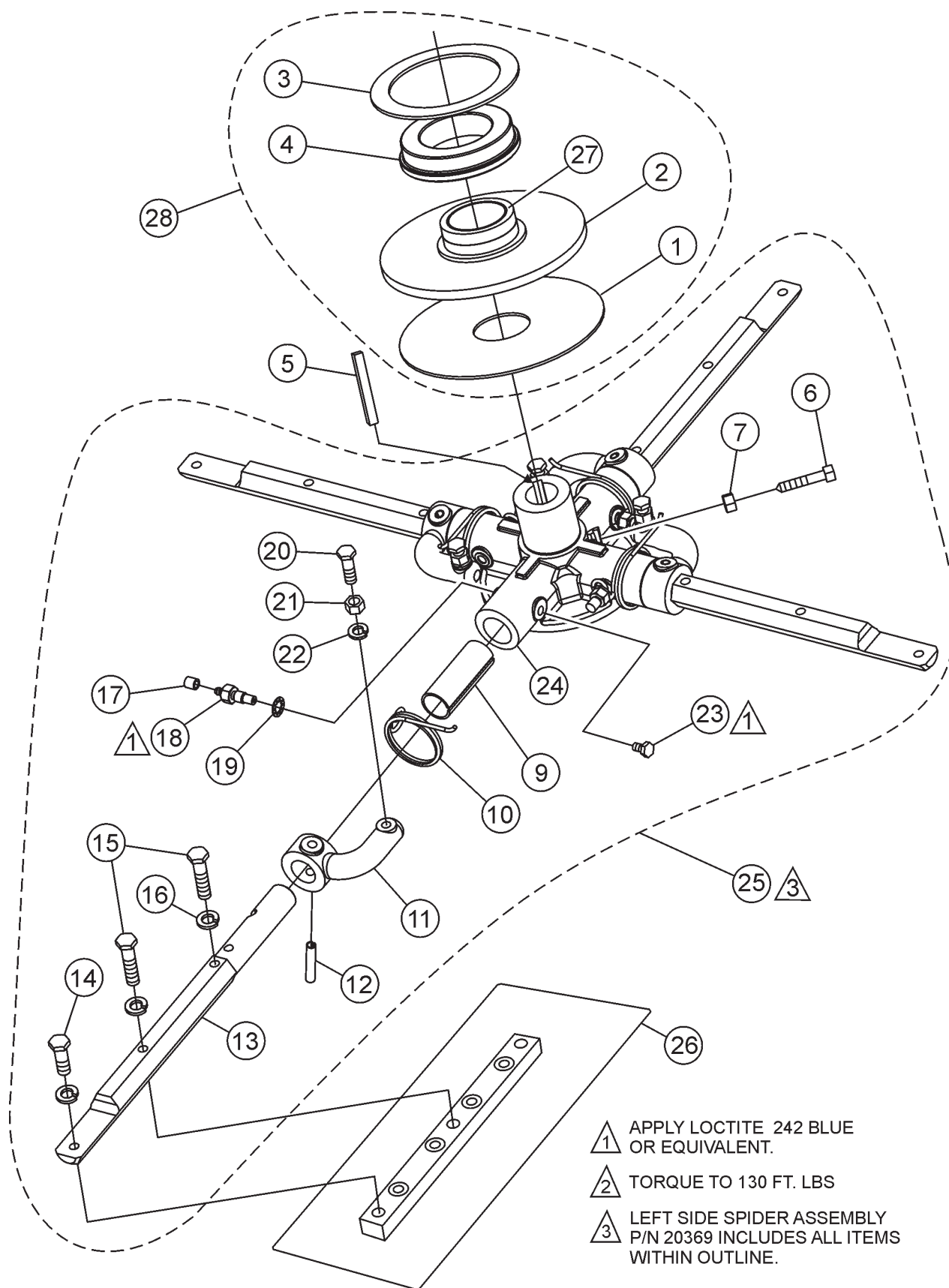
# JWN-SERIES — SPIDER ASSY. (RIGHT)

## SPIDER ASSY. (RIGHT)

<u>NO.</u>	<u>PART NO.</u>	<u>PART NAME</u>	<u>QTY.</u>	<u>REMARKS</u>
1%	1154A	PLATE, WEAR THRUST COLLAR	1	
2%+	10793	THRUST COLLAR W/ BUSHING .....	1	INCLUDES ITEMS W/+
3%	12208	WEAR RING	1	
4%	12778	BEARING, THRUST 6013 2RSW/ FLANGE	1	
5	1141	KEY, 5/16 SQ. X 2-5/8	1	
6*	12097	SCREW, SQHS 3/8- 16 X 1-3/4 CONE 8	1	
7*	1456	NUT, HEX FINISH 3/8- 16	1	
9*	1157A	BUSHING, TROWEL ARM	4	
10*	1317	SPRING, LH TROWEL ARM LEVER	4	
11*	1555	LEVER, TROWEL ARM LEFT HAND	4	
12*	4164	PIN, ROLL 5/16 X 1-3/4	4	
13*	20408	ARM, TROWEL JWN RIGHT	4	
14*	0202	SCREW, HHC 5/16-18 X 1	8	
15*	0105	SCREW, HHC 5/16-18 X 1-1/2	16	
16*	0161C	WASHER, LOCK, 5/16 MED	24	
17*	1162A	CAP, GREASE ZERK #2	4	
18*	1322	SCREW ASSY. , ARM RETAINING	4	
19*	1875	WASHER, INT. SHKP. 3/8	4	
20*	0164B	SCREW, TROWEL ADJUSTMENT	4	
21*	1876	NUT, HEX JAM 3/8- 16 CLASS 2B	4	
22*	0166A	WASHER, LOCK, 3/8 MEDIUM	4	
23*#	11602	SCREW, HHC 3/8-16 X 1/4 .....	4	REPLACES P/N 2218
24*#	12478	SPIDER, KIT .....	1	INCLUDES ITEMS W/# PLUS INSTRUCTIONS
25	20370	PLATE, SPIDER ASSEMBLY RIGHT SIDE .....	1	INCLUDES ITEMS W/*
26		BLADE ASSEMBLY .....	4	CONTACT UNIT SALES DEPT./ ACCESSORY ITEM
27+%	1471	THRUST COLLAR BUSHING	1	
28%	10968	THRUST COLLAR KIT .....	1	INCLUDES ITEMS W/%

# JWN-SERIES — SPIDER ASSY. (LEFT)

## SPIDER ASSY. (LEFT)



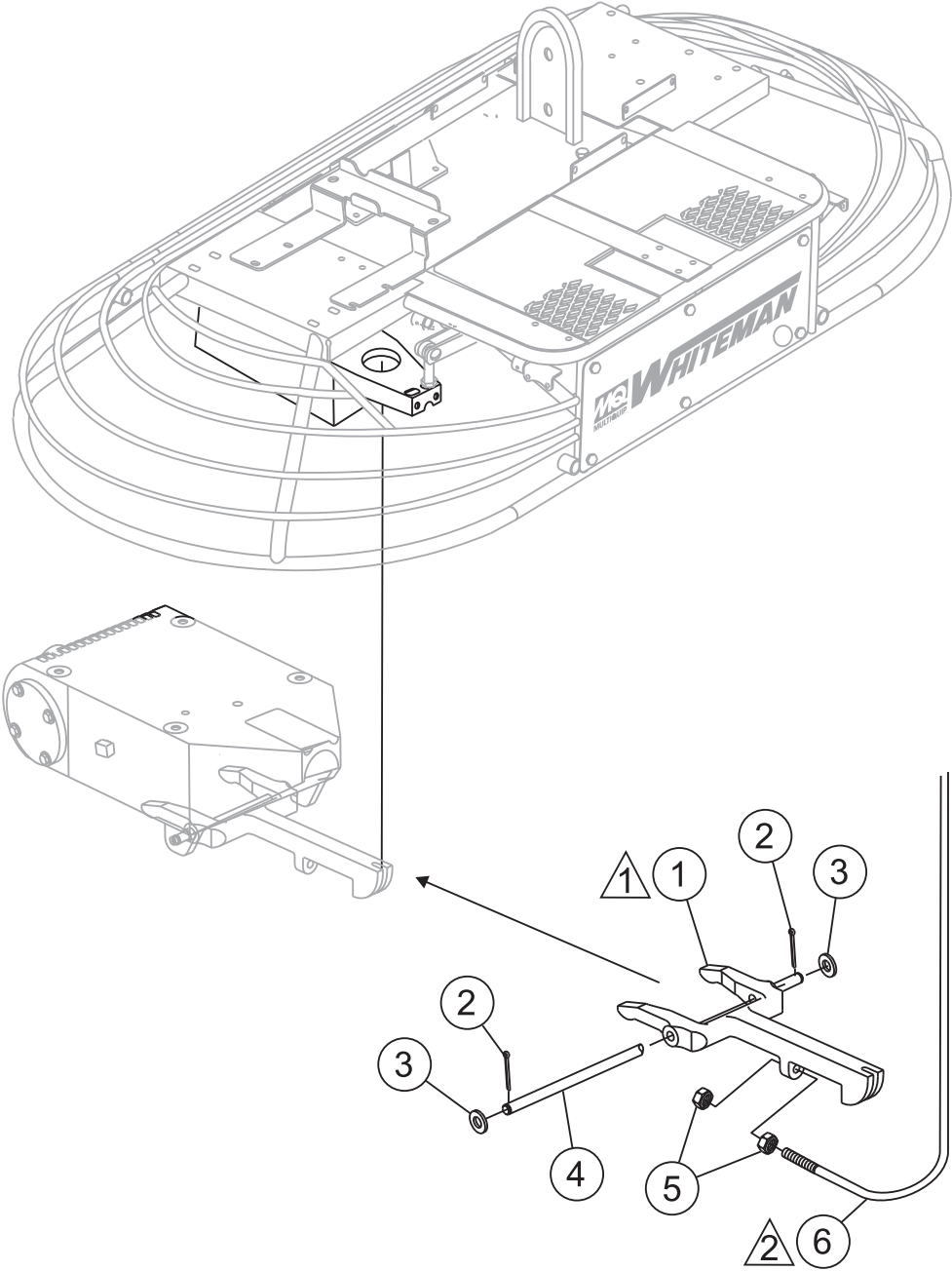
## JWN-SERIES — SPIDER ASSY. (LEFT)

### SPIDER ASSY. (LEFT)

<u>NO.</u>	<u>PART NO.</u>	<u>PART NAME</u>	<u>QTY.</u>	<u>REMARKS</u>
1%	1154A	PLATE, WEAR THRUST COLLAR	1	
2%+	10793	THRUST COLLAR W/ BUSHING .....	1	INCLUDES ITEMS W/+
3%	12208	WEAR RING	1	
4%	12778	BEARING, THRUST 6013 2RSW/ FLANGE	1	
5	1141	KEY, 5/16 SQ. X 2-5/8	1	
6*	12097	SCREW, SQHS 3/8- 16 X 1-3/4 CONE 8	1	
7*	1456	NUT, HEX FINISH 3/8- 16	1	
9*	1157A	BUSHING, TROWEL ARM	4	
10*	1316	SPRING, RH TROWEL ARM LEVER	4	
11*	1163	LEVER, TROWEL ARM RIGHT HAND	4	
12*	4164	PIN, ROLL 5/16 X 1-3/4	4	
13*	20409	ARM, TROWEL JWN LEFT	4	
14*	0202	SCREW, HHC 5/16-18 X 1	8	
15*	0105	SCREW, HHC 5/16-18 X 1-1/2	16	
16*	0161C	WASHER, LOCK, 5/16 MED	24	
17*	1162A	CAP, GREASE ZERK #2	4	
18*	1322	SCREW ASSY. , ARM RETAINING	4	
19*	1875	WASHER, INT. SHKP. 3/8	4	
20*	0164B	SCREW, TROWEL ADJUSTMENT	4	
21*	1876	NUT, HEX JAM 3/8- 16 CLASS 2B	4	
22*	0166A	WASHER, LOCK, 3/8 MEDIUM	4	
23*#	11602	SCREW, HHC 3/8-16 X 1/4 .....	4	REPLACES P/N 2218
24*#	12478	SPIDER, KIT .....	1	INCLUDES ITEMS W/# PLUS INSTRUCTIONS
25	20369	PLATE, SPIDER ASSEMBLY LEFT SIDE .....	1	INCLUDES ITEMS W/*
26		BLADE ASSEMBLY .....	4	CONTACT UNIT SALES DEPT./ ACCESSORY ITEM
27+%	1471	THRUST COLLAR BUSHING	1	
28%	10968	THRUST COLLAR KIT .....	1	INCLUDES ITEMS W/%

# JWN-SERIES — YOKE ASSY.

YOKE ASSY.



NOTES:

△ 1 LEFT AND RIGHT YOKE ASSEMBLIES IDENTICAL.

△ 2 SEE PITCH ASSEMBLY.

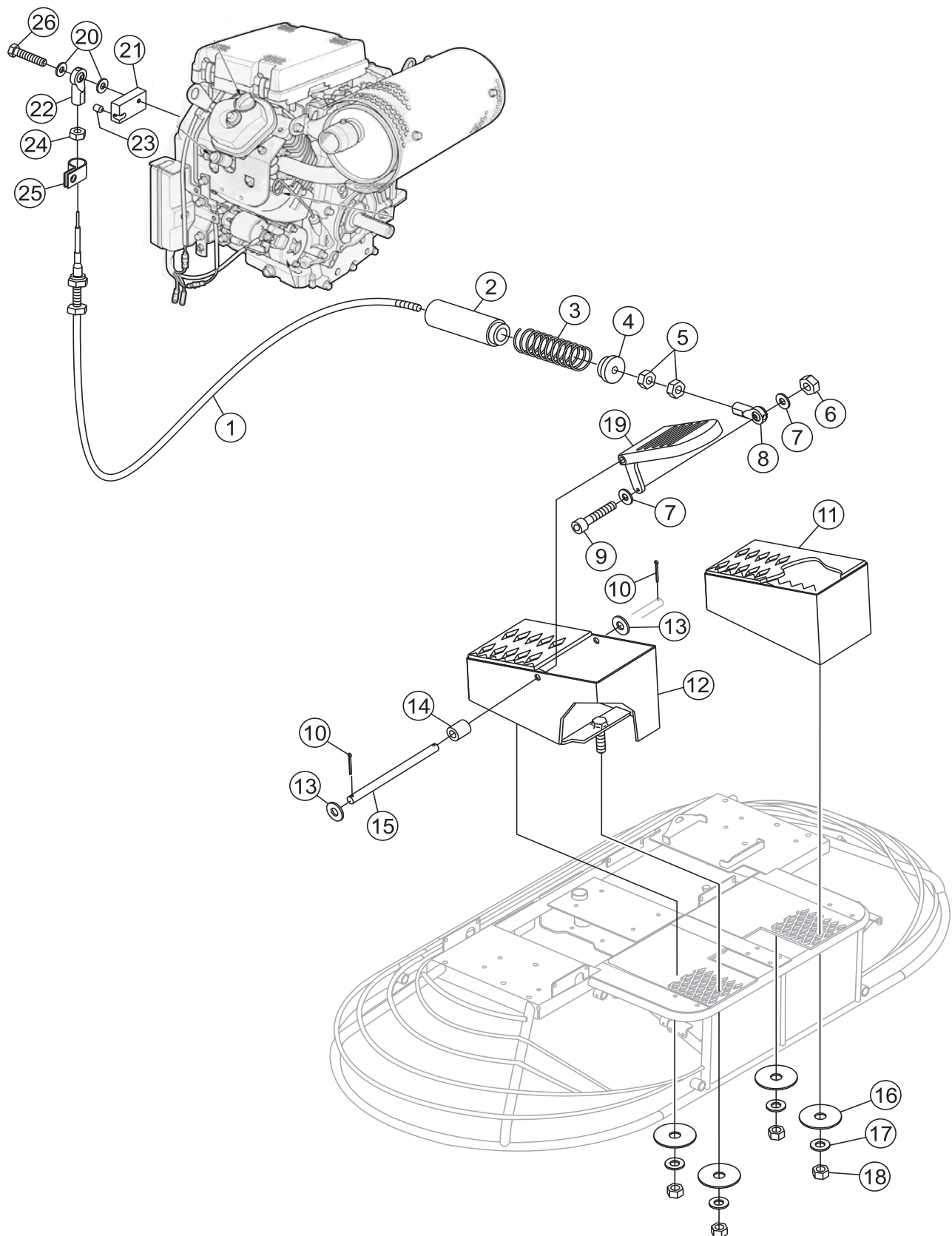
## JWN-SERIES — YOKE ASSY.

YOKE ASSY.

<u>NO.</u>	<u>PART NO.</u>	<u>PART NAME</u>	<u>QTY.</u>	<u>REMARKS</u>
1	9027	YOKE	2	
2	0683	PIN, COTTER 3/32 X 3/4	4	
3	10136	WASHER, FLAT 3/8 SAE	4	
4	9028	PIN, YOKE	2	
5	1116	NUT, BRASS JAM 5/16-18	4	
6	2008	CABLE ASSEMBLY 25.63	2	

# JWN-SERIES — FOOT PEDALS/THROTTLE ASSY.

FOOT PEDALS/THROTTLE ASSY.





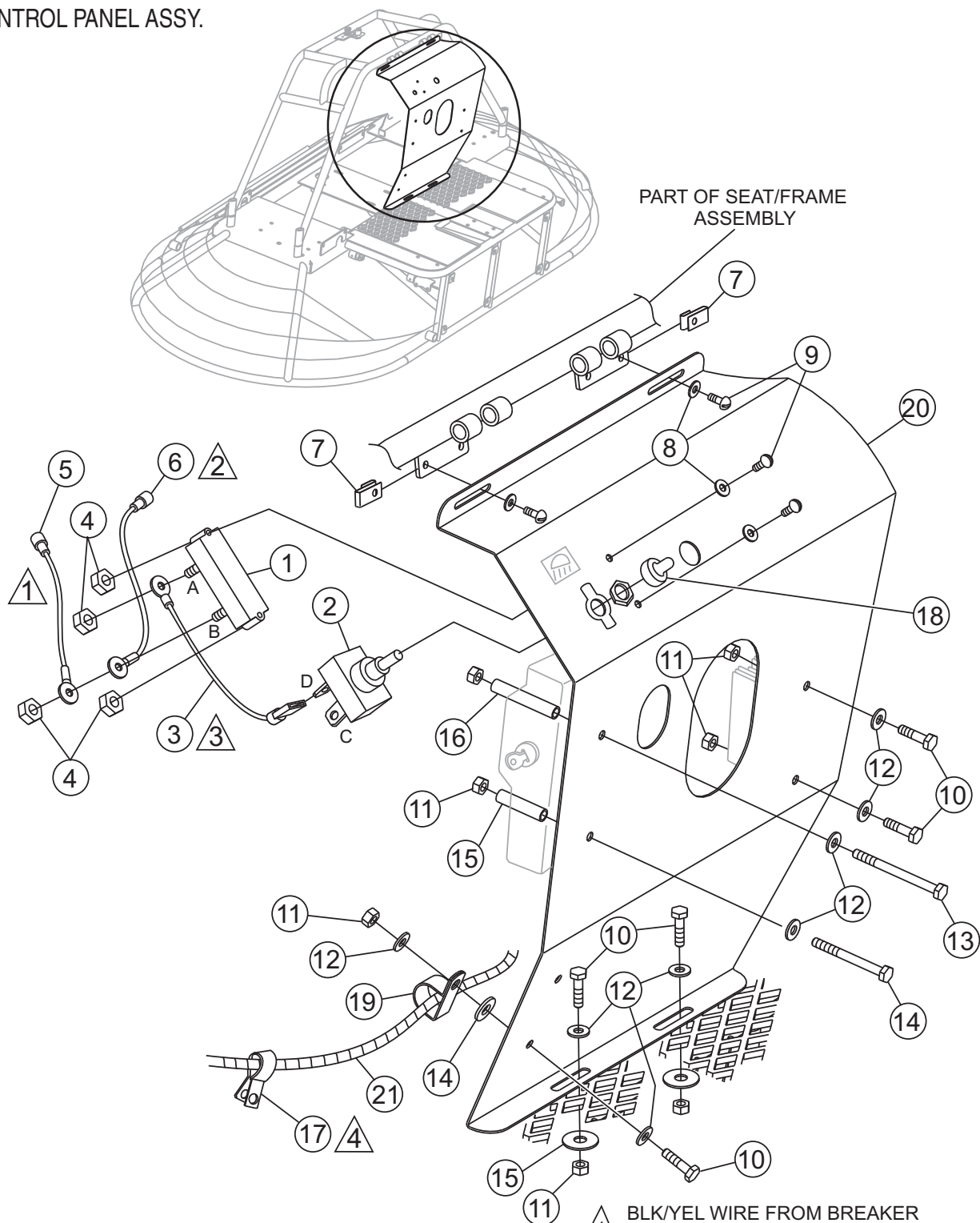
## JWN-SERIES — FOOT PEDALS/THROTTLE ASSY.

### FOOT PEDALS/THROTTLE ASSY.

<u>NO.</u>	<u>PART NO.</u>	<u>PART NAME</u>	<u>QTY.</u>	<u>REMARKS</u>
1	20348	CABLE, CONTROL 10-32 X 33 LONG	1	
2	2754	ADAPTER, THROTTLE SPRING, LONG	1	
3	2753	SPRING, THROTTLE RETURN	1	
4	2755	ADAPTER, THROTTLE SPRING, SHORT	1	
5	0937	NUT, HEX 10-32 ZINC PLTD	2	
6	10019	NUT, NYLOC 10- 32	1	
7	2203	WASHER, FLAT #10 SAE	2	
8	2153	ROD END, 10- 32 FEMALE RIGHT HAND	1	
9	10018	SCREW, SHC 10- 32 X 1	1	
10	6014B	PIN, COTTER 3/32 X 1	2	
11	12657-1	RISER, LEFT FOOT	1	
12	12656-1	RISER, RIGHT FOOT	1	
13	10136	WASHER, FLAT 3/8 SAE	2	
14	3083	SPACER, 3/4 X 3/8 X 7/8 LONG	1	
15	2772	PIN, ACCELERATOR PEDAL	1	
16	3233	WASHER, FENDER 1.50D X 3/8 ID	4	
17	0300B	WASHER, FLAT 5/16 SAE	4	
18	5283	NUT, NYLOC 5/16-18	4	
19	2086	PEDAL ACCELERATOR	1	
20	2203	WASHER, FLAT #10 SAE	2	
21	20335	LEVER, ENGINE CONTROL	1	
22	2153	ROD END, 10-32 FEMALE RH	1	
23	10450	SCREW, SHS 10-32 X 1/4	1	
24	0937	NUT, HEX 10-32	1	
25	19473	CLAMP, HOSE WORM #2 1/4 TO 5/8	1	
26	3513	SCREW, HHC 10-32 X 1	1	

# JWN-SERIES — CONTROL PANEL ASSY.

CONTROL PANEL ASSY.



- ▲ 1 BLK/YEL WIRE FROM BREAKER TERMINAL "B" TO HONDA BLK/YEL WIRE.
- ▲ 2 BLK/YEL WIRE FROM BREAKER TERMINAL "A" TO HONDA BLK/YEL WIRE.
- ▲ 3 WHITE WIRE FROM LIGHT SWITCH TERMINAL "D" TO BREAKER TERMINAL "B".
- ▲ 4 INSTALL CLAMP TO SCREW ON ENGINE.

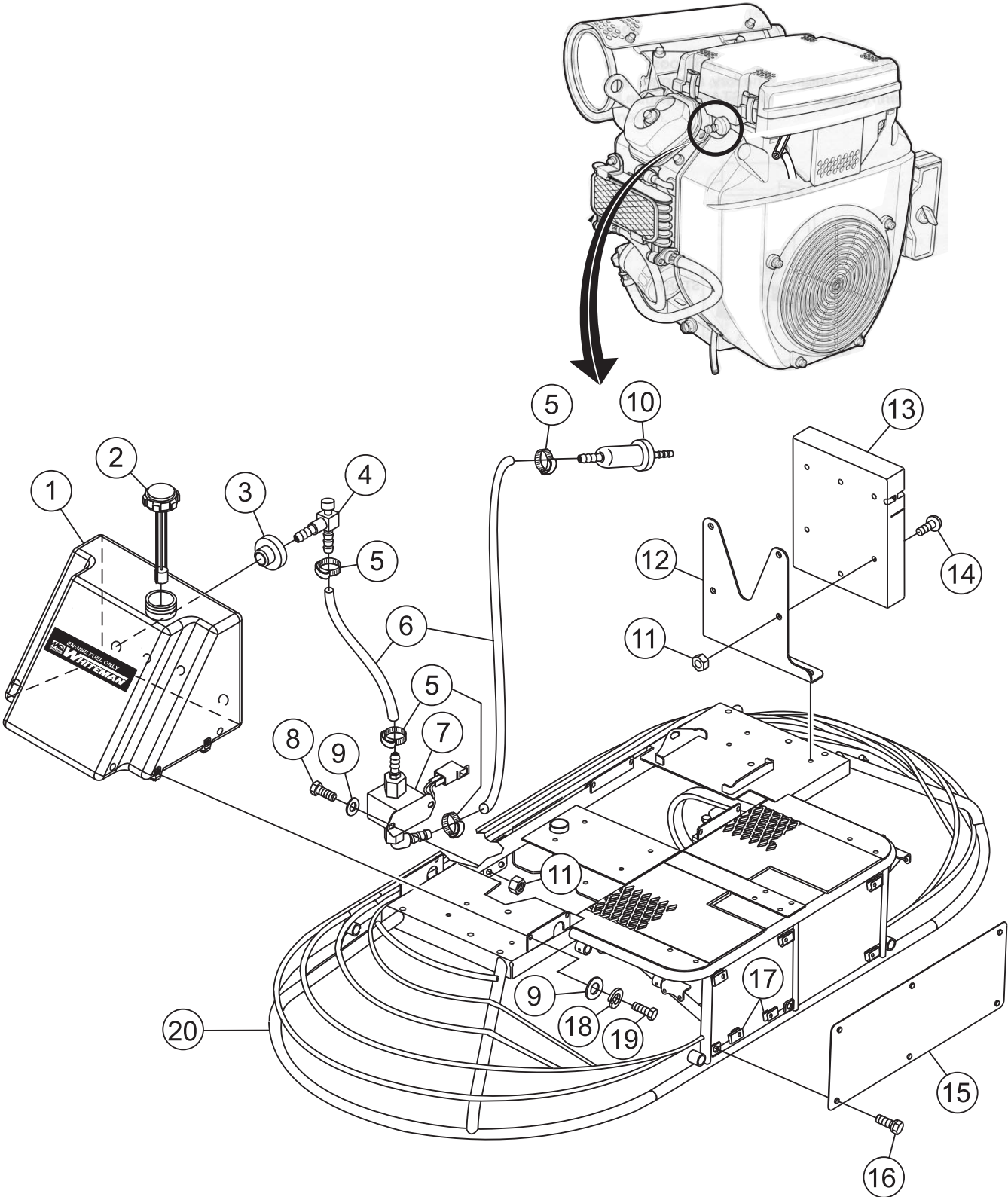
## JWN-SERIES — CONTROL PANEL ASSY.

### CONTROL PANEL ASSY.

<u>NO.</u>	<u>PART NO.</u>	<u>PART NAME</u>	<u>QTY.</u>	<u>REMARKS</u>
1	2673	CIRCUIT BREAKER, 30A, 12V	1	
2	4682	SWITCH, TOGGLE ELECTRIC #9061	1	
3	20344	WIRE ASSEMBLY, 16 GA. X 5"	1	
4	10019	NUT, NYLOC 10- 32	4	
5	20342	WIRE ASSEMBLY, 16 GA. X 7"	1	
6	20343	WIRE ASSEMBLY, 16 GA. X 10"	1	
7	10284	LOCK PLATE, CLIP-ON 10-32	2	
8	2203	WASHER, FLAT #10 SAE	4	
9	5065B	SCREW, RHM 10- 32 X 1/2	4	
10	0730	SCREW, HHC 1/4- 20 X 1	5	
11	10024	NUT, NYLOC 1/4- 20	7	
12	0948	WASHER, FLAT, 1/4 SAE	8	
13	19380	SCREW, HHC 1/4- 20 X 3 PLTD	1	
14	4538	SCREW, HHC 1/4- 20 X 2-1/2	1	
15	20341	SPACER, .38 OD X .05 X 1.56	1	
16	20340	SPACER, .38 OD X .05 W X 2.19	1	
17	8125	CLAMP, HOSE SUPPORT, 5/8	1	
18	8381	BOOT, TOGGLE SWITCH	1	
19	11505	CLAMP, HOSE SUPPORT 1/2 INCH LONG	1	
20	20339	CONTROL PANEL	1	
21	20419	HARNESS, WIRE HONDA RIDER	1	

# JWN-SERIES — FRAME/FUEL ASSY.

FRAME/FUEL ASSY.



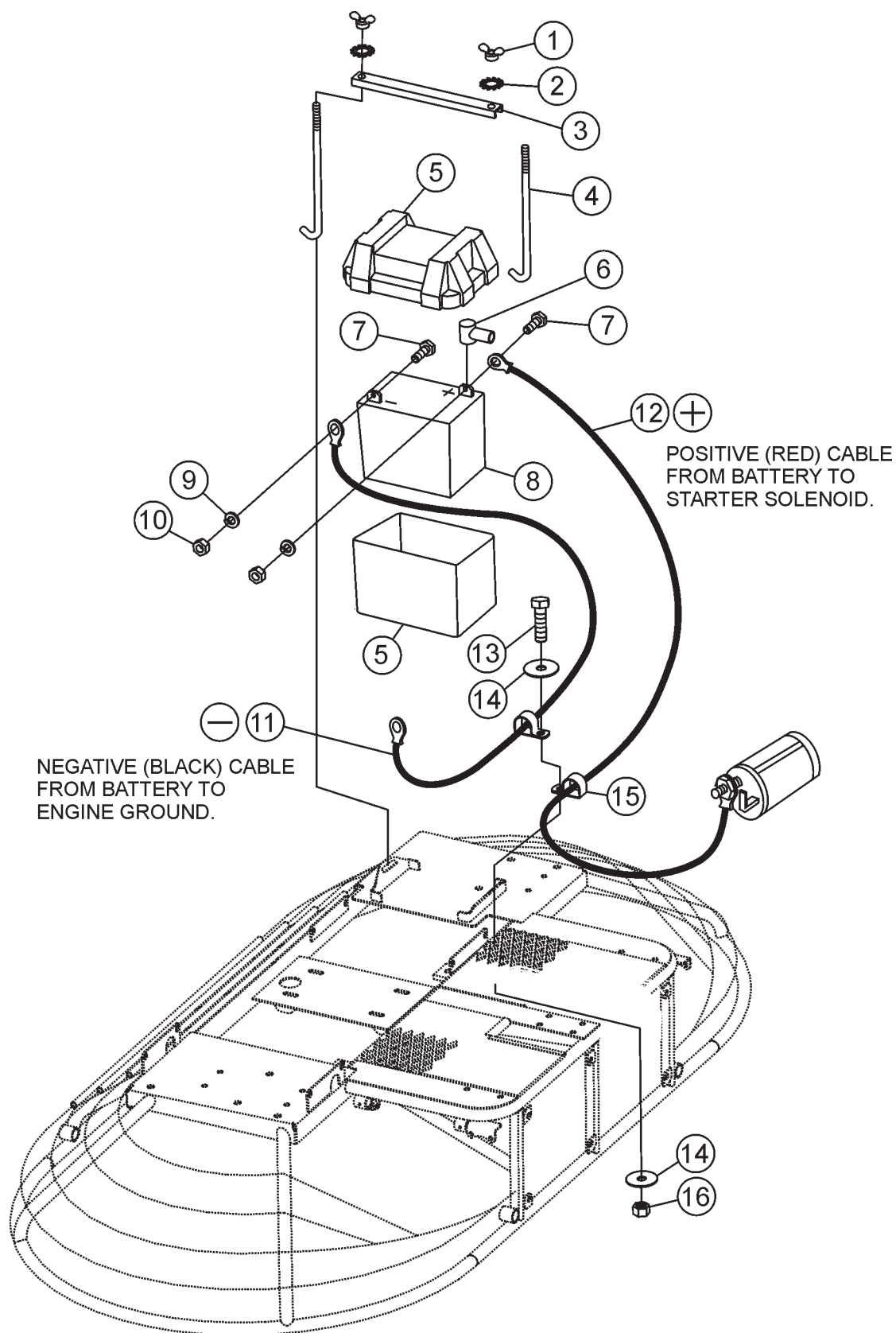
# JWN-SERIES — FRAME/FUEL ASSY.

FRAME/FUEL ASSY.

<u>NO.</u>	<u>PART NO.</u>	<u>PART NAME</u>	<u>QTY.</u>	<u>REMARKS</u>
1	12404	TANK, FUEL FIVE GALLON	1	
2	11418	FUEL CAP/GAUGE (10.5)	1	
3	19633	BUSHING, RUBBER FUEL	1	
4	TBD	FITTING, 90 4BARB- 4BARB FUEL	1	
5	19473	CLAMP, WORM HOSE, #4 (1/4- 5/8)	3	
6	60013	HOSE, RUBBER FUEL 0.25 ID .....	2	SOLD IN FT. LENGTHS
7	20907	FUEL PUMP ASSEMBLY	1	
8	4514	SCREW, HHC 1/4-20 X 5/8	2	
9	0948	WASHER, FLAT, 1/4 SAE	6	
10	16910ZE8015	FILTER, FUEL	1	
11	10024	NUT, NYLOC 1/4- 20	4	
12	20366	BRACKET, OP MANUAL BOX	1	
13	29057	DOCUMENT BOX, (CP90007- 07)	1	
14	12287	SCREW, THP 1/4- 20 X 3/4 SS	4	
15	20943-1	FRONT PANEL .....	1	REPLACES P/N 2818
16	11819	SCREW, HHC, WASHER 1/4- 20 X 3/4	6	
17	11534	NUT U-TYPE 1/4- 20	6	
18	0181B	WASHER, LOCK, 1/4 MED	6	
19	4514	SCREW, HHC 1/4- 20 X 5/8	4	
20	20014-1	FRAME	1	

# JWN-SERIES — BATTERY ASSY.

## BATTERY ASSY.



## JWN-SERIES — BATTERY ASSY.

BATTERY ASSY.

<u>NO.</u>	<u>PART NO.</u>	<u>PART NAME</u>	<u>QTY.</u>	<u>REMARKS</u>
1	2509	WING NUT, PLATED	2	
2	10031	WASHER, EXT SHKP 1/4	2	
3	20356	BRACKET BATTERY HOLD- DOWN	1	
4	20194	BOLT, BATTERY HOLD DOWN	2	
5	2449	BOX, BATTERY GR UI	1	
6	2762	BOOT, TERMINAL	1	
7	0131A	SCREW, HHC 1/4- 20 X 3/4	2	
8		BATTERY, GR. UI WET W /TAG .....	1	..... USE INTERSTATE BATTERY SP-40
9	0181B	WASHER, LOCK, 1/4 MEDIUM	2	
10	0949	NUT, HEX FINISH 1/4- 20	2	
11	12022	CABLE, NEG 20- 1/2	1	
12	12675	CABLE, POS. BATTERY, 36' ‘	1	
13	2623	SCREW, HHC 5/16- 18 X 1- 1/4	1	
14	3233	WASHER, FINDER 1.5 OD X 3/8 ID	2	
15	11505	CLAMP, HOSE SUPPORT 1/2 INCH LONG	2	
16	5283	NUT, NYLOC 5/16- 18	1	





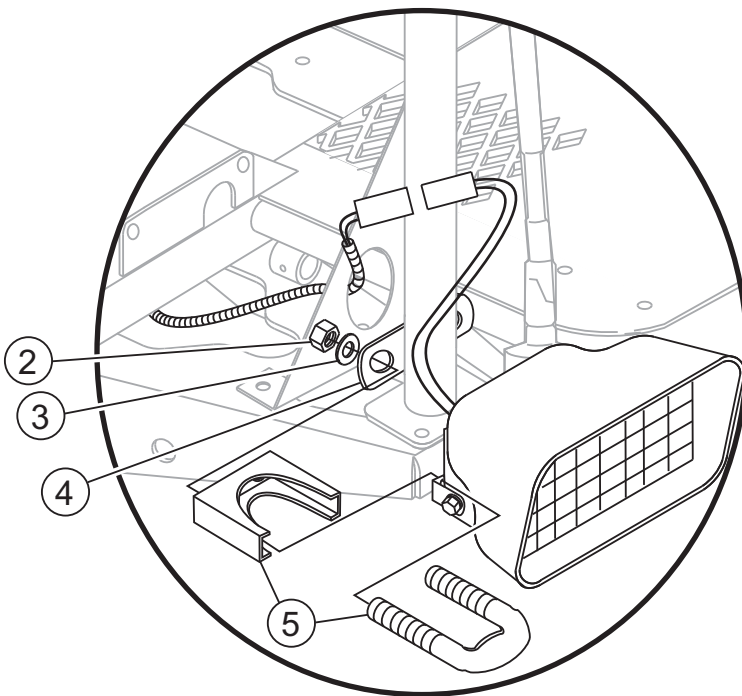
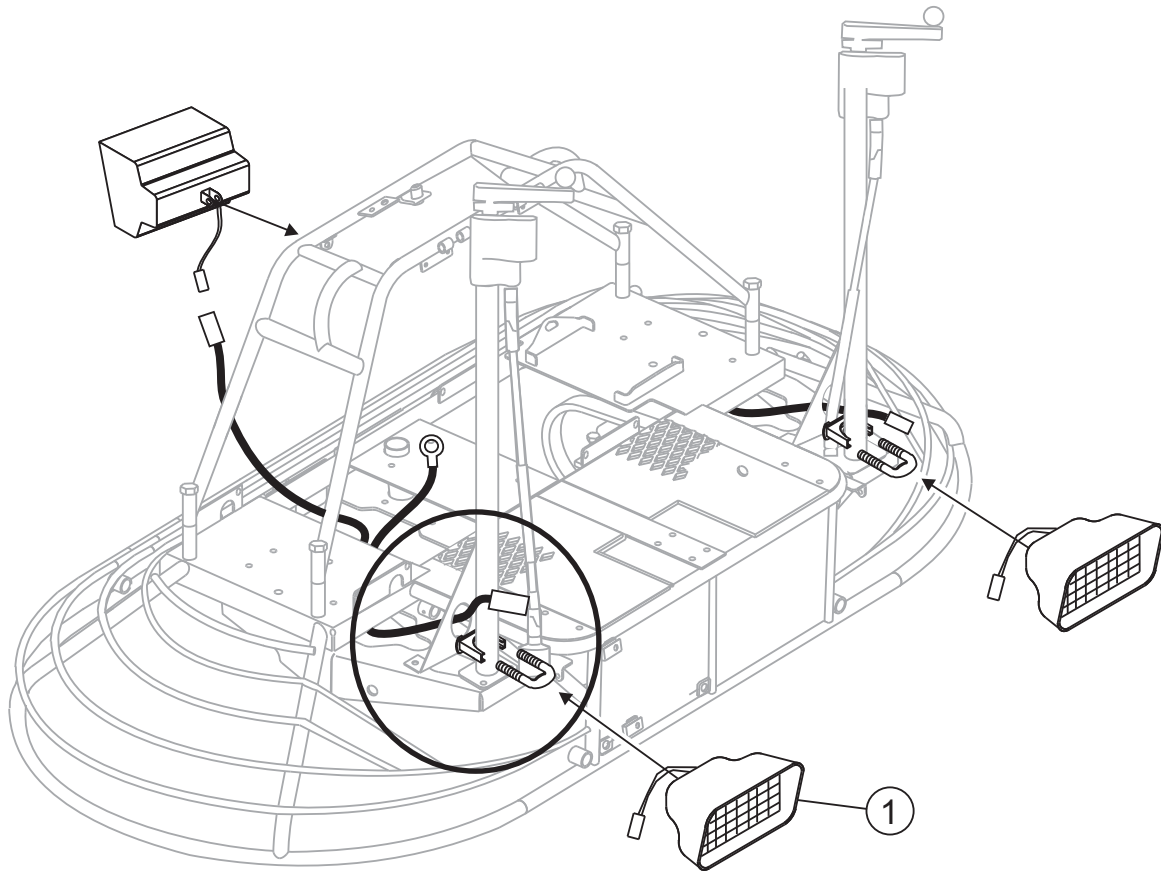
# JWN-SERIES — SPRAY ASSY.

## SPRAY ASSY.

<u>NO.</u>	<u>PART NO.</u>	<u>PART NAME</u>	<u>QTY.</u>	<u>REMARKS</u>
1	392292	NOZZLE, SPRAY	1	
2	2898	WASHER, BONDED NEOPRENE 1 X 1/2	1	
3	11222	MOUNT, SPRAY NOZZLE	1	
4	1023	SCREW, HHC 3/8-16 X 1 1/4	2	
5	10136	WASHER, FLAT 3/8 SAE	4	
6	10024	NUT, NYLOC 1/4-20	4	
7	2912	FITTING, 90 4BARB-1/4FP	1	
8	8128	CLAMP, HOSE SUPPORT 5/16	1	
9	0948	WASHER, FLAT 1/4 SAE	4	
10	0131A	SCREW, HHC 1/4-20 X 3/4	4	
11	2914	HOSE, 1/4 ID.....	1	SOLD IN FOOT LENGTHS
12	10022	FITTING, PLASTIC 6BARB-4BARB	1	
13	2918	CLAMP, HOSE .475 - .536 ID	4	
14	2913	HOSE, 3/8 ID.....	1	SOLD IN FOOT LENGTHS
15	12548	PUMP, SPRAY ASSY. SHURFLO 100-000-21	1	
16	2925	FITTING, PLASTIC 90 6BARB-3/8 MP	1	
17	2398	CLAMP, 6 1/2 HOSE SIZE 96	2	
18	2926	SCREEN, STRAINER	1	
19	2108	CAP, SPRAY TANK	1	
20	2916	TANK, WATER NPT BOSSES	1	
21	2478	DRAIN COCK	1	
22	2399	U-BOLT, 1 ID PLTD W/NUTS	2	
23	2887	MOUNT, TANK LEFT	1	
24	2886	MOUNT, TANK RIGHT	1	
25	10133	NUT, NYLOC 3/8-16	4	
26	8125	CLAMP, HOSE SUPPORT 5/8	1	
27	11430	SWITCH ASSY. , SPRAY	1	

# JWN-SERIES — LIGHT ASSY.

LIGHT ASSY.



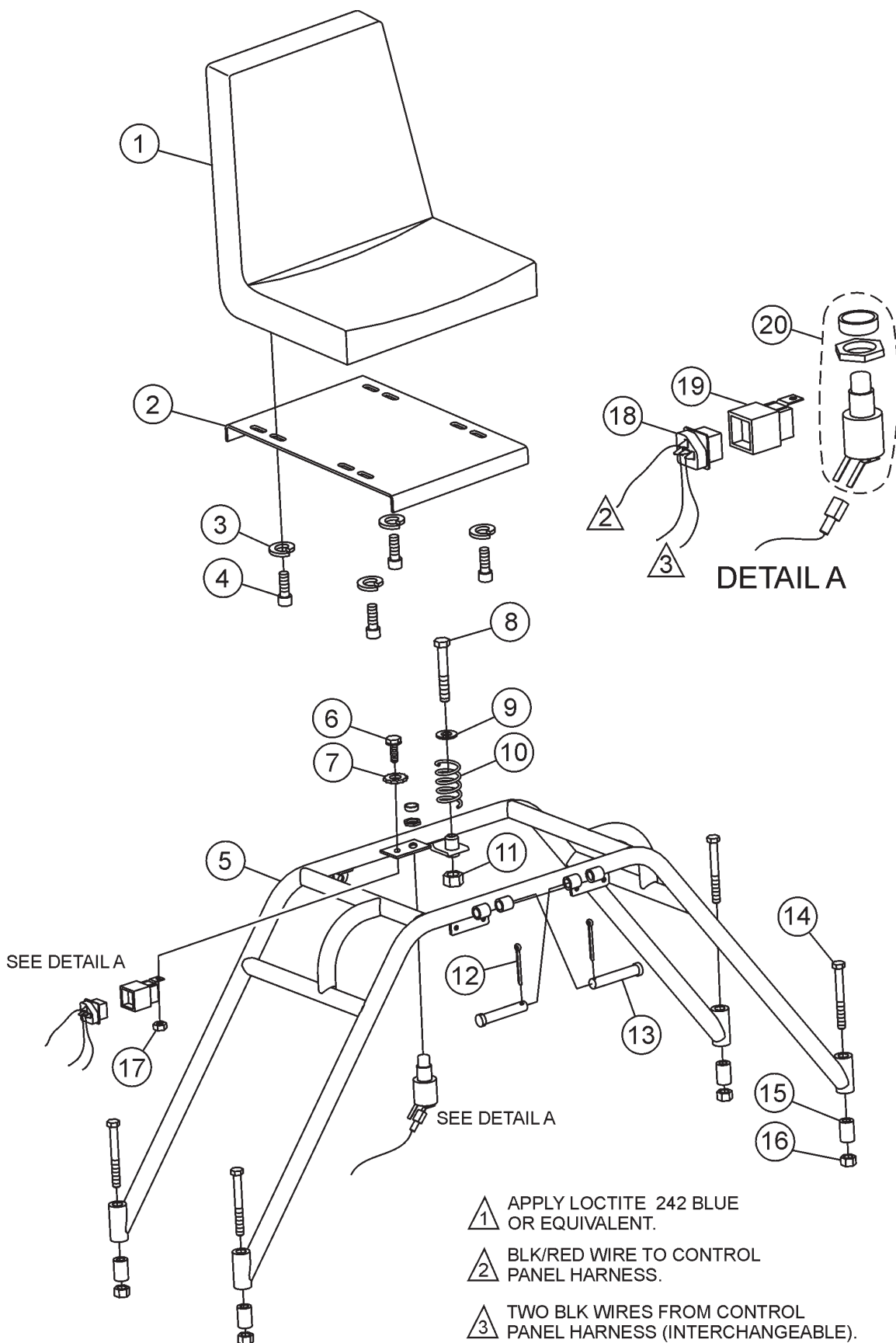
## JWN-SERIES—LIGHT ASSY.

LIGHT ASSY.

<u>NO.</u>	<u>PART NO.</u>	<u>PART NAME</u>	<u>QTY.</u>	<u>REMARKS</u>
1	2896	LIGHT KIT ASSEMBLY	3	
2	5283	NUT, NYLOC 5/16-18	4	
3	0300B	WASHER, FLAT 5/16 SAE	4	
4	2531	BRACKET, LIGHT SIDE	2	
5	2534	CLAMP ASSEMBLY, MUFFLER 1-3/4	2	

# JWN-SERIES — SEAT FRAME ASSY.

SEAT FRAME ASSY.



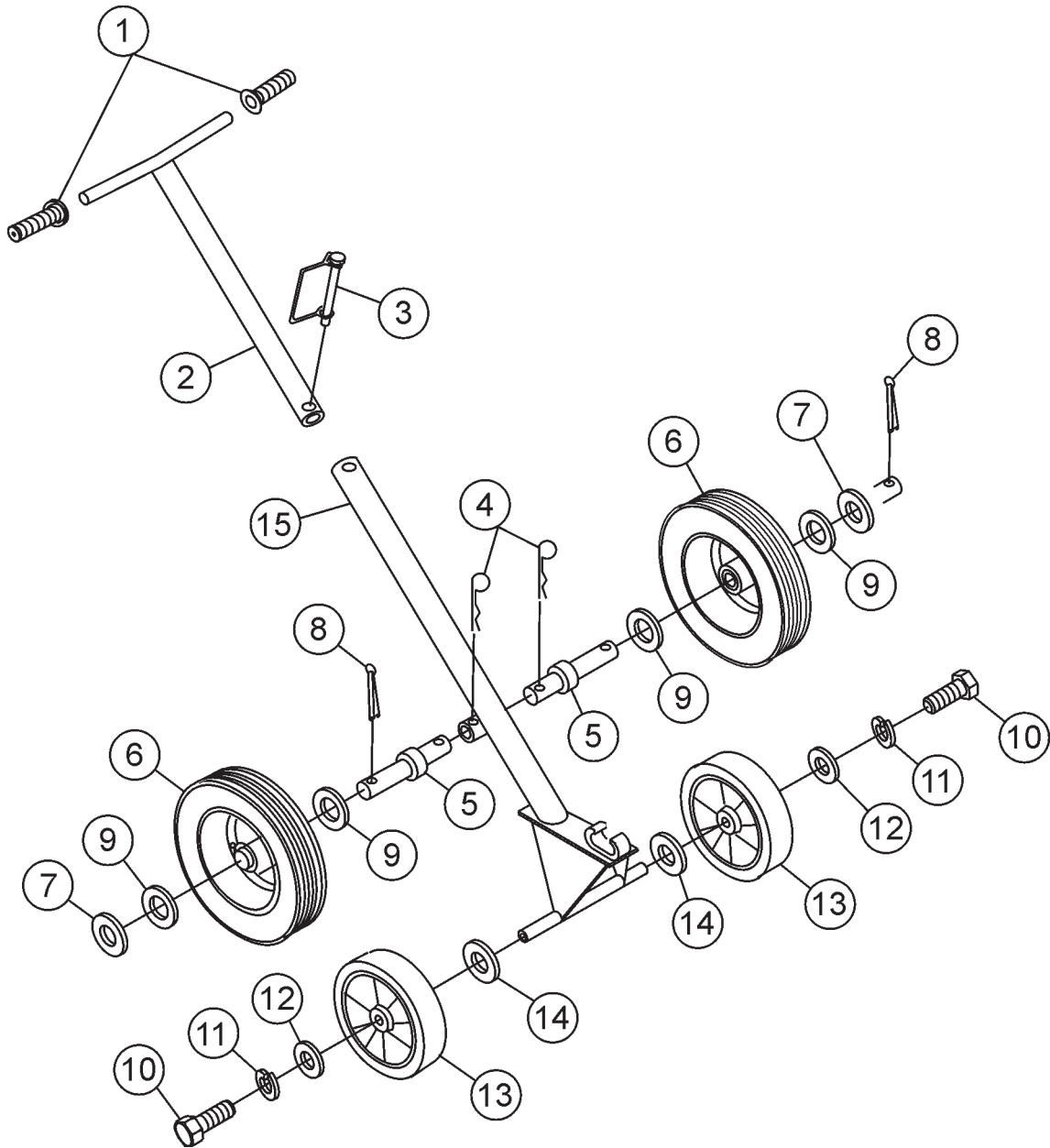
## JWN-SERIES — SEAT FRAME ASSY.

### SEAT FRAME ASSY.

<u>NO.</u>	<u>PART NO.</u>	<u>PART NAME</u>	<u>QTY.</u>	<u>REMARKS</u>
1	2351	SEAT	1	
2	2421	SEAT PLATE	1	
3	0161C	WASHER, LOCK, 5/16 MEDIUM	4	
4	1237	SCREW, SHC, 5/16- 18 X 7/8 NYLOC	4	
5	2889	FRAME, SEAT	1	
6	11644	SCREW, HHC, WASHER 10- 32 X 5/8	1	
7	10237	WASHER, EXT. SHKP, #10	1	
8	8156	SCREW, HHC 3/8- 16 X 2-1/2	1	
9	4001	WASHER, FLAT 3/8 PLTD STD. USS	1	
10	11593	SPRING, THROTTLE RETURN	1	
11	10133	NUT, NYLOC 3/8- 16	1	
12	0183	PIN, COTTER 1/8 1-1/4	2	
13	8081	PIN, CLEVIS 1/2 X 2.75 EFF.	2	
14	10306	SCREW, HHC 1/2- 13 X 4-1/2	4	
15	20346	SPACER, .56 ID. X 1.00 OD X 1.5L	4	
16	10176	NUT, NYLOC 1/2- 13	4	
17	10019	NUT, NYLOC 10- 32	1	
18	12018	CONNECTOR, RELAY	1	
19	12017	RELAY, KILL	1	
20	12005	SWITCH, KILL COLE- HER #90036- 02	1	

# JWN-SERIES — EZ-MOVER ASSY.

EZ-MOVER ASSY.



## JWN-SERIES — EZ-MOVER ASSY.

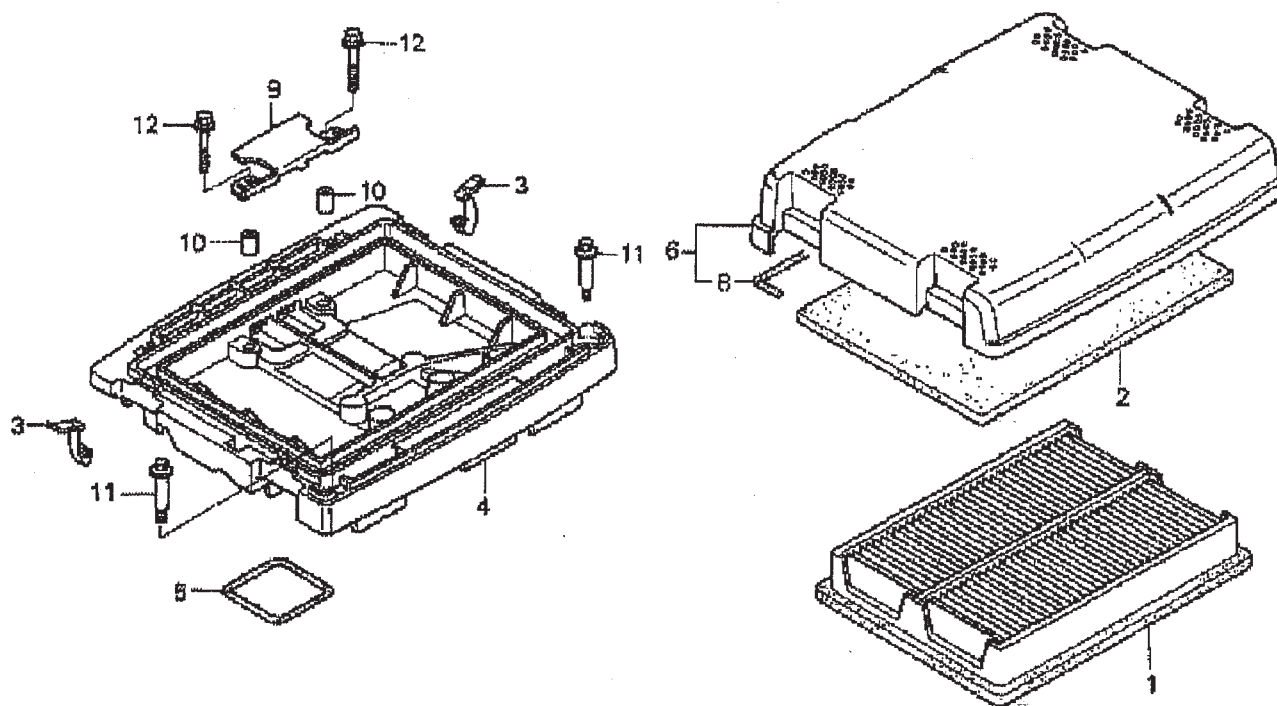
### EZ-MOVER ASSY.

<u>NO.</u>	<u>PART NO.</u>	<u>PART NAME</u>	<u>QTY.</u>	<u>REMARKS</u>
1	0189	HAND GRIP	2	
2	2336	HANDLE, UPPER	1	
3	1869	PIN, SNAP	1	
4	7170	CLIP	2	
5	11684	AXLE, DOLLY	2	
6	10440	WHEEL & TIRE	2	
7	8151	WASHER, FLAT 3/4 SAE	2	
8	0183	PIN, COTTER	2	
9	10446	WASHER, FLAT 3/4	4	
10	0655	SCREW, HHCS 5/16-18 X 3/4	2	
11	0161C	WASHER, LOCK 5/16	2	
12	0300B	WASHER, FLAT 5/16	2	
13	2364	WHEEL	2	
14	4684	WASHER, FLAT 5/8	2	
15	10445	FRAME	1	

EZ-MOVER ASSEMBLY -- PURCHASE THROUGH MQ UNIT SALES DEPT.

# HONDA GX-670 — AIR CLEANER ASSY.

AIR CLEANER ASSY.





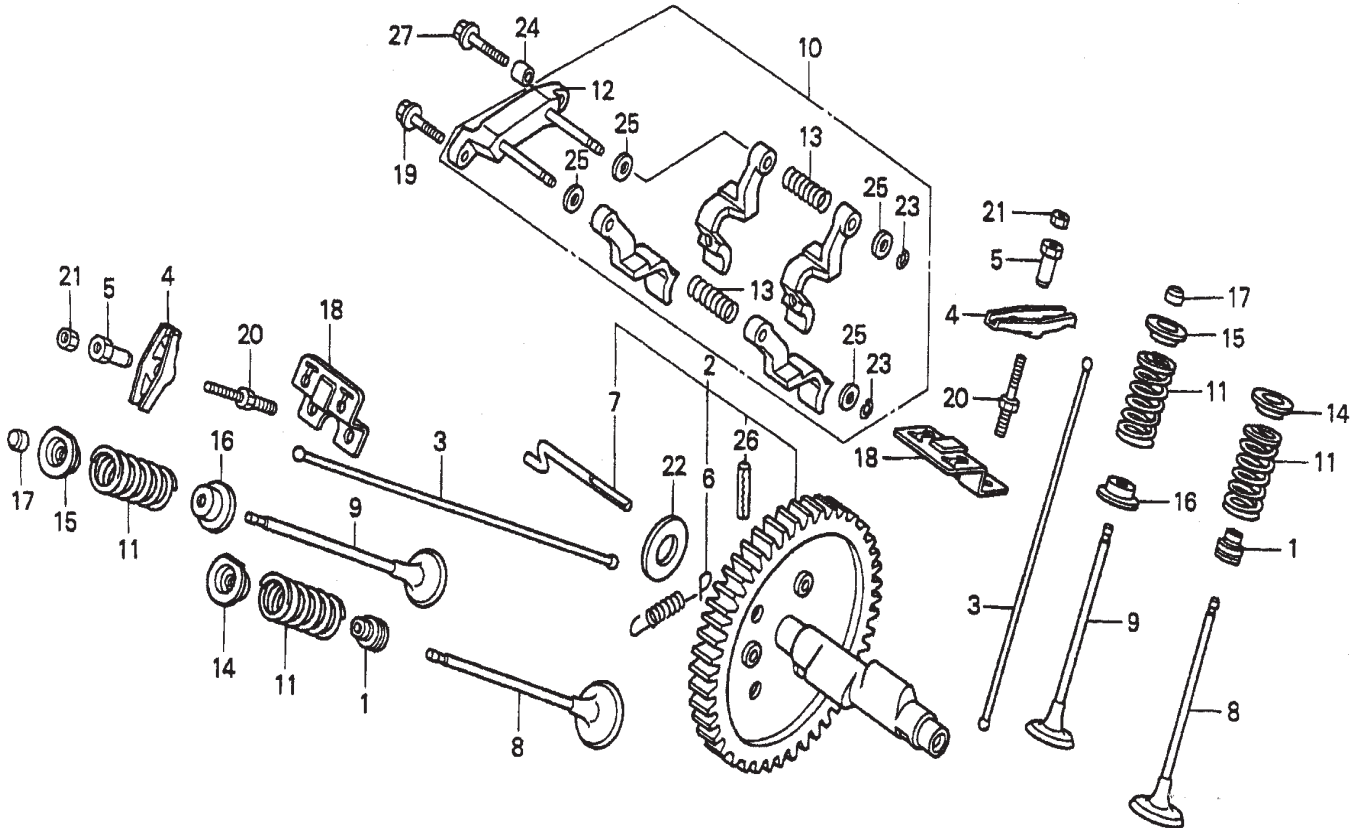
## HONDA GX-670 — AIR CLEANER ASSY.

### AIR CLEANER ASSY.

<u>NO.</u>	<u>PART NO.</u>	<u>PART NAME</u>	<u>QTY.</u>	<u>REMARKS</u>
1	17210ZJ1841	ELEMENT COMP., AIR CLEANER	1	
2	17218ZJ1840	FILTER, OUTER	1	
3	17219ZJ1840	CLIP, AIR CLEANER	4	
4	17220ZN1000	HOUSING COMP., AIR CLEANER	1	
5	17229ZN1000	SEAL, AIR CLEANER HOUSING	1	
6	17230ZJ1840	COVER ASSEMBLY, AIR CLEANER	1	
8	17233ZJ1840	SEAL, AIR CLEANER COVER	1	
9	17234ZJ1840	PLATE, AIR CLEANER SETTING	1	
10	17238ZJ4830	COLLAR A, AIR CLEANER	2	
11	90003ZJ1840	BOLT, SPECIAL 5MM	2	
12	957010602800	BOLT, FLANGE 6 X 28	2	

# HONDA GX-670 — CAMSHAFT ASSY.

## CAMSHAFT ASSY.



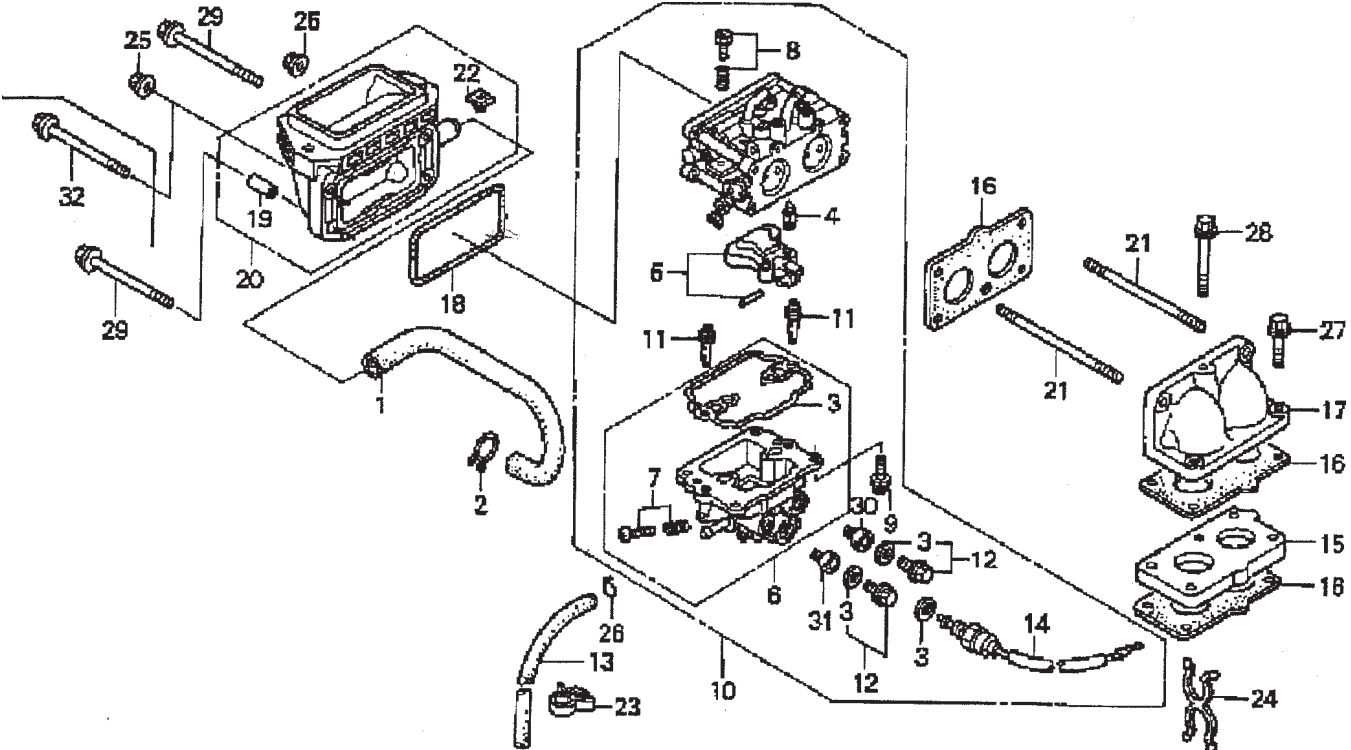
# HONDA GX-670 — CAMSHAFT ASSY.

## CAMSHAFT ASSY.

<u>NO.</u>	<u>PART NO.</u>	<u>PART NAME</u>	<u>QTY.</u>	<u>REMARKS</u>
1	12209ZE8003	SEAL, VALVE STEM	2	
2	14100ZJ1842	CAMSHAFT ASSEMBLY .....	1	INCLUDES ITEMS W/%
3	14410ZJ1840	ROD, PUSH	4	
4	14431ZE2010	ARM, VALVE ROCKER	4	
5	14451ZE1013	PIVOT, ROCKER ARM	4	
6%	14568ZJ1841	SPRING, WEIGHT RETURN	1	
7%	14576ZJ1840	PIN, DECOMPRESSION	1	
8	14711ZE3000	VALVE IN.	2	
9	14721ZE3000	VALVE, EX.	2	
10	14730ZJ1840	LIFTER ASSEMBLY, VALVE .....	1	INCLUDES ITEMS W/*
11	14751ZE2003	SPRING, VALVE	4	
12*	14760ZJ1840	SHAFT COMP., VALVE LIFTER	1	
13*	14764ZJ1840	SPRING, VALVE LIFTER	2	
14	14771ZE2000	RETAINER, IN. VALVE SPRING	2	
15	14773ZE2000	RETAINER, EX. VALVE SPRING	2	
16	14775ZE2010	SEAT, VALVE	2	
17	14781ZE2000	ROTATOR, VALVE	2	
18	14791ZE2010	PLATE, PUSH ROD GUIDE	2	
19	90005895000	BOLT, FLANGE 5 X 16	1	
20	90012ZE0010	BOLT, PIVOT 8MM	4	
21	90206ZE1000	NUT, PIVOT ADJ.	4	
22	90446357000	WASHER, THRUST 17.2MM	1	
23*	90602ZE1000	CLIP, GOVERNOR HOLDER	2	
24	9430108120	PIN A, DOWEL 8 X 12	1	
25*	9410106800	WASHER, PLAIN 6MM	4	
26%	9430560282	PIN, SPRING 6 X 28	1	
27	957010602500	BOLT, FLANGE 6 X 25	1	

# HONDA GX-670 — CARBURETOR ASSY.

CARBURETOR ASSY.



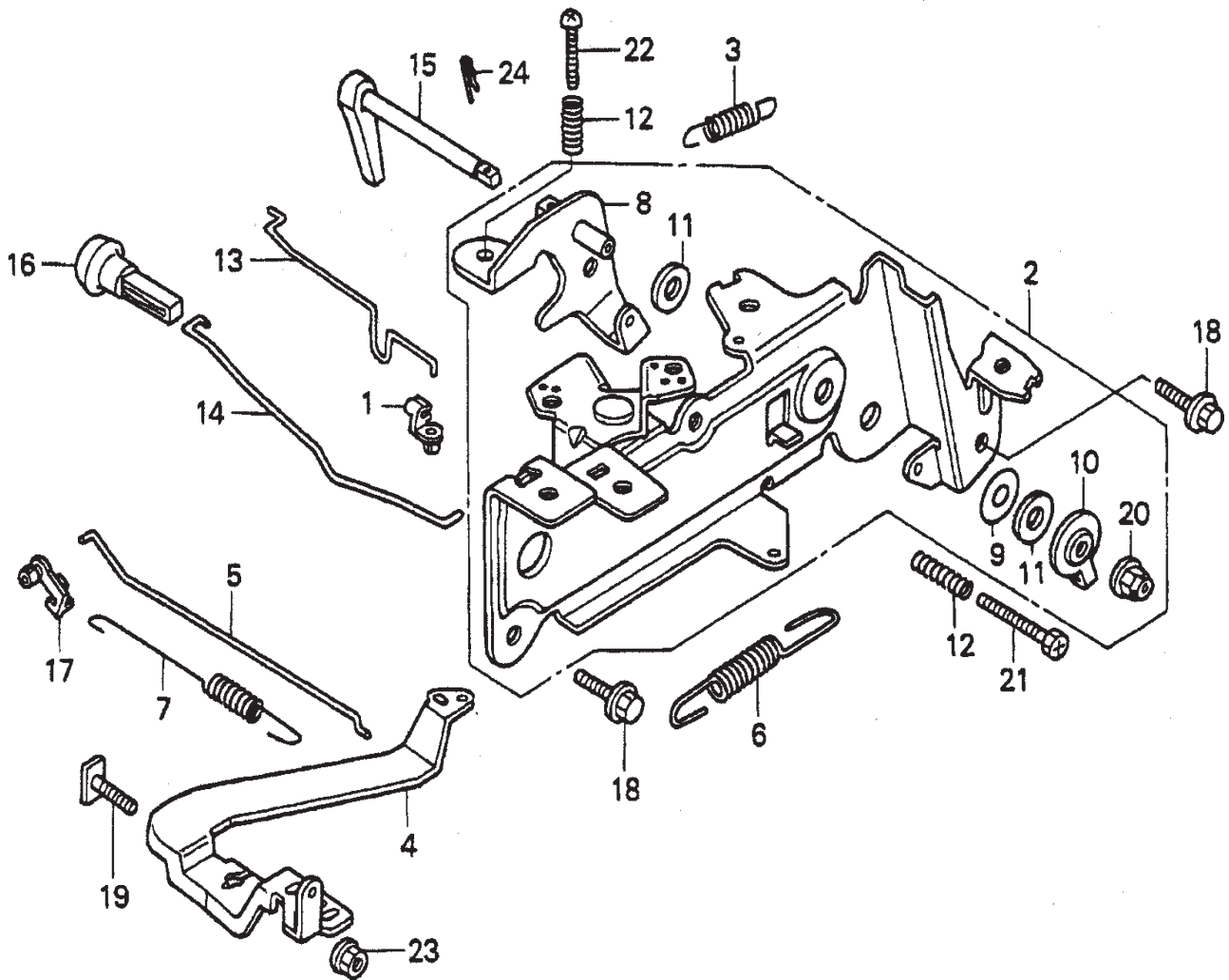
# HONDA GX-670 — CARBURETOR ASSY.

## CARBURETOR ASSY.

<u>NO.</u>	<u>PART NO.</u>	<u>PART NAME</u>	<u>QTY.</u>	<u>REMARKS</u>
1	12357ZJ1840	TUBE, BREATHER	1	
2	15772551000	CLIP, BREATHER TUBE	1	
3*+	16010ZN1003	GASKET SET	1	
4*	16011ZN1003	VALVE, FLOAT	1	
5*	16013ZN1003	FLOAT SET	1	
6*	16015ZN1003	CHAMBER SET, FLOAT .....	1	INCLUDES ITEMS W/+
7*+	16024ZN1003	SCREW SET, DRAIN	1	
8*	16028ZN1003	SCREW SET	1	
9*	16081ZN1003	SCREW-WASHER	4	
10	16100ZN1003	CARBURETOR ASSEMBLY (TB01A A) .....	1	INCLUDES ITEMS W/*
11*	16150ZN1003	JET, SLOW #54	2	
12*	16181ZN1003	PLUG SET	2	
13	16198ZJ1840	TUBE, DRAIN	1	
14*	16200ZN1003	VALVE ASSEMBLY, SOLENOID	1	
15	16211ZN1000	INSULATOR, CARBURETOR	1	
16	16221ZN1000	GASKET, CARBURETOR	3	
17	17103ZN1010	ELBOW, MANIFOLD	1	
18	17228ZN1000	GASKET, AIR CLEANER	1	
19%	17238ZJ4830	COLLAR A, AIR CLEANER	4	
20	17410ZN1000	ELBOW COMP., AIR CLEANER .....	1	INCLUDES ITEMS W/%
21	90048ZC3000	BOLT, STUD 6 X 85	2	
22%	90314ZJ1840	NUT, INSERT 6MM	2	
23	90682959661	CLIP B, CABLE	1	
24	91402ZJ1841	CLIP, PURSE LOCK	1	
25	9405006000	NUT, FLANGE 6MM	2	
26	9500202080	CLIP, TUBE (B8)	1	
27	957010603000	BOLT, FLANGE 6 X 30	2	
28	957010606500	BOLT, FLANGE 6 X 65	1	
29	958010609008	BOLT, FLANGE 6 X 90	2	
30*	99101ZN10920	JET, MAIN #92 (OPTIONAL)	1	
30	99101ZN10960	JET, MAIN #96 (OPTIONAL)	1	
31*	99101ZN11020	JET, MAIN #102	1	
31	99101ZN10940	JET, MAIN #94 (OPTIONAL)	1	
31	99101ZN10980	JET, MAIN #98 (OPTIONAL)	1	
31	99101ZN11000	JET, MAIN #100	1	
32	958010609008	BOLT, FLANGE 6 X 90	2	

# HONDA GX-670 — CONTROL ASSY.

CONTROL (2) ASSY.



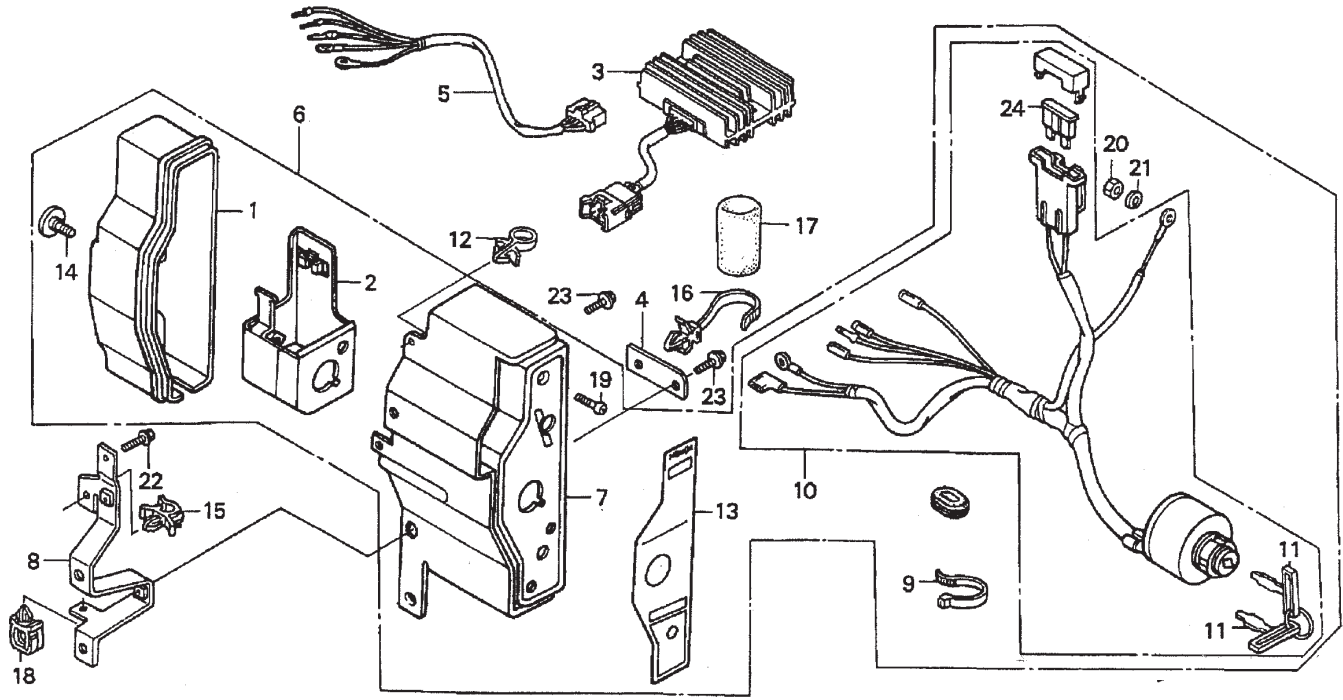
# HONDA GX-670 — CONTROL ASSY.

CONTROL (2) ASSY.

<u>NO.</u>	<u>PART NO.</u>	<u>PART NAME</u>	<u>QTY.</u>	<u>REMARKS</u>
1	16263883W10	JOINT, ROD	1	
2	16500ZJ1850	CONTROL ASSEMBLY .....	1	INCLUDES ITEMS W/*
3	16534ZN1000	SPRING, STARTER	1	
4	16551ZJ1840	ARM, GOVERNOR	1	
5	16555ZN1000	ROD, GOVERNOR	1	
6	16561ZN1800	SPRING, GOVERNOR (MANUAL)	1	
7	16562ZN1000	SPRING, THROTTLE RETURN	1	
8*	16570ZJ1850	ARM COMP., CONTROL	1	
9*	16574883300	SPRING, LEVER	1	
10*	16575ZJ1850	WASHER, CONTROL ARM	1	
11*	16576883300	SPACER, CONTROL LEVER	2	
12	16584883300	SPRING, CONTROL ADJUSTING	2	
13	16611ZN1000	ROD, CHOKE CONTROL	1	
14	16628ZJ1850	ROD, CHOKE KNOB	1	
15	17850ZJ1850	LEVER ASSEMBLY, THROTTLE	1	
16	17951921030	KNOB, CHOKE	1	
17	17957ZV4000	BUSH, LINKAGE	1	
18	90014952000	BOLT, FLANGE 6 X 14	2	
19	90015ZE3790	BOLT, GOVERNOR ARM	1	
20*	90114SA0000	NUT, SELF- LOCK 6MM	1	
21	92301050250A	BOLT, SLOT 5 X 25	1	
22	93500050250A	SCREW, PAN 5 X 25	1	
23	9405006000	NUT, FLANGE 6MM	1	
24	9425110000	PIN, LOCK 10MM	1	

# HONDA GX-670 — CONTROL BOX ASSY.

## CONTROL BOX ASSY.





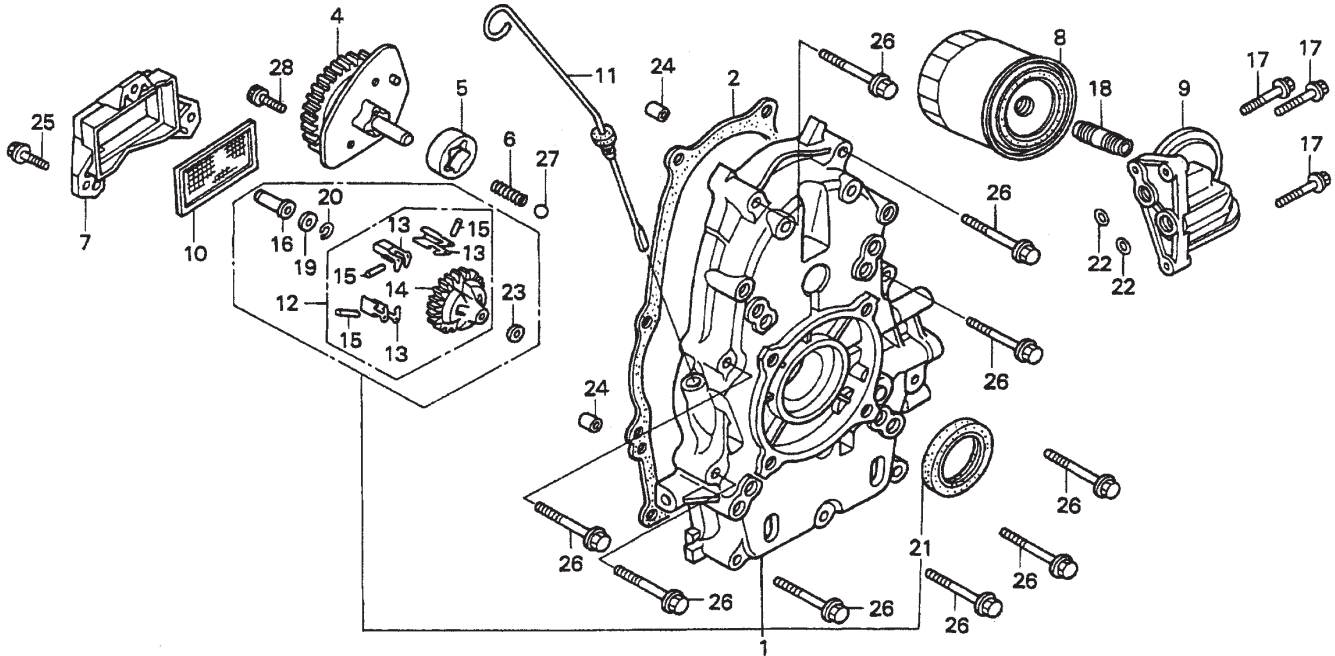
# HONDA GX-670 — CONTROL BOX ASSY.

## CONTROL BOX ASSY.

<u>NO.</u>	<u>PART NO.</u>	<u>PART NAME</u>	<u>QTY.</u>	<u>REMARKS</u>
1*	31612ZE2003	CASE, CONTROL	1	
2*	31614ZE2003	BRACKET, CASE MOUNTING	1	
3	31620ZG5003	RECTIFIER ASSEMBLY REGULATOR 20A	1	
4	32103759000	BRACKET, WIRE HARNESS CLIP	1	
5	32105ZJ1800	SUB- WIRE HARNESS ASSEMBLY	1	
6	32340ZJ1841	BOX ASSEMBLY CONTROL .....	1	INCLUDES ITEMS W/*
7*	32345ZJ1811	PANEL COMP., CONTROL	1	
8	32349ZJ1840	STAY, CONTROL BOX	1	
9*	32902892003	BAND	1	
10*	35100ZJ1841	SWITCH ASSEMBLY COMBINATION .....	1	INCLUDES ITEMS W/%
11*%	35111880003	KEY COMP.	2	
12	36103ZE1000	HOLDER, STOP SWITCH WIRE	1	
13*	87529ZE2860	MARK, CONTROL BOX, EXTERNAL- REG.	1	
14*	90380MA6010	SCREW, SPECIAL 6 X 12	1	
15	32171GJ1003	CLIP, WIRE HARNESS	1	
16	90676SA8003	BAND, WIRE HARNESS 150MM (BLUE)	1	
17	91408ZJ1810	TUBE, CORD 30MM	1	
18	91504750003	CLIP, WIRE HARNESS	1	
19	93500040120H	SCREW, PAN 4 X 12	1	
20*	94001040800S	NUT, HEX. 4MM	1	
21*	9411104800	WASHER, SPRING 4MM	1	
22	957010601000	BOLT, FLANGE 6 X 10	1	
23	957010601200	BOLT, FLANGE 6 X 12	2	
24*%	9820032500	FUSE, BLADE 25A	1	

# HONDA GX-670 — CRANKCASE COVER ASSY.

CRANKCASE COVER ASSY.



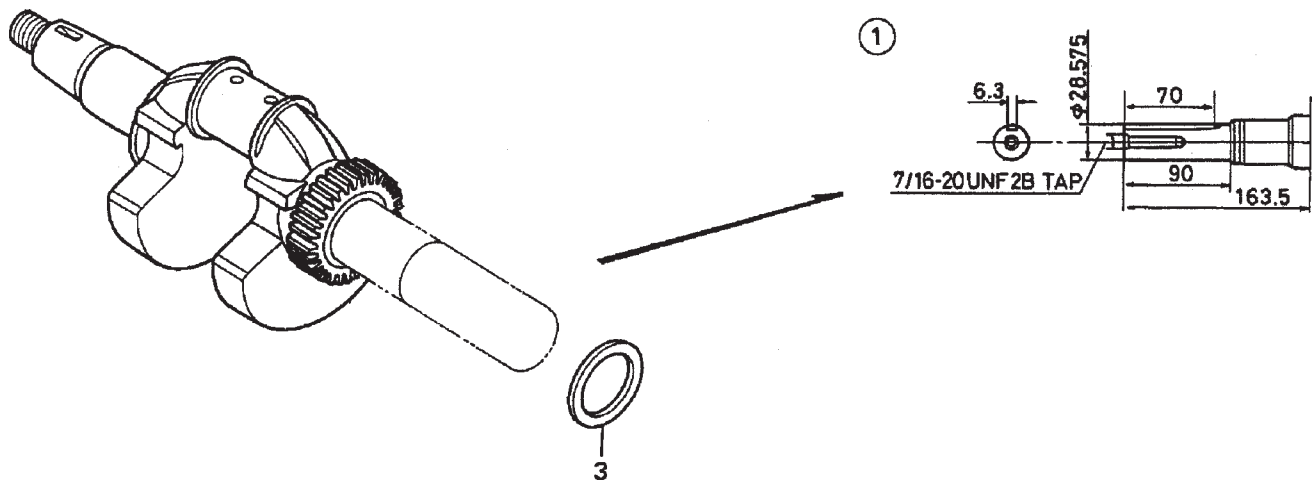
# HONDA GX-670 — CRANKCASE COVER ASSY.

## CRANKCASE COVER ASSY.

<u>NO.</u>	<u>PART NO.</u>	<u>PART NAME</u>	<u>QTY.</u>	<u>REMARKS</u>
1	11300ZJ1840	COVER ASSEMBLY, CRANKCASE (Q- TYPE) ....	1	INCLUDES ITEMS W/*
2	11381ZJ1840	GASKET, CASE COVER	1	
4	15124ZJ1000	COVER ASSEMBLY, OIL PUMP	1	
5	15124ZJ1003	ROTOR, OIL PUMP (OUTER)	1	
6	15232ZJ1000	SPRING RELIEF VALVE	1	
7	15348ZJ1840	COVER, OIL FILTER	1	
8	15400PT7005	FILTER, OIL (FILTECH INC.)	1	
8	15410ZJ4999AH	FILTER, OIL	1	
9	15411ZN1000	BASE, OIL FILTER	1	
10	15427ZJ1000	SCREEN, OIL FILTER	1	
11	15655ZJ1860	DIPSTICK, OIL	1	
12*	16510ZJ1840	GOVERNOR ASSEMBLY .....	1	INCLUDES ITEMS W/%
13*%	16511ZJ1840	WEIGHT, GOVERNOR	3	
14*%	16512ZJ1840	HOLDER, GOVERNOR WEIGHT	1	
15*%	16513ZE2000	PIN, GOVERNOR WEIGHT	3	
16*	16531ZE2000	SLIDER, GOVERNOR	1	
17	90015883000	BOLT, FLANGE 6 X 28	3	
18	90018PN3000	HOLDER, OIL FILTER	1	
19*	90473147000	WASHER 6 X 16	1	
20*	90602ZE1000	CLIP, GOVERNOR HOLDER	1	
21*	91201ZJ1841	OIL SEAL 38 X 58 X 9	1	
22	91320MJ6003	O- RING 11.8 X 2.4	2	
23*	9410106800	WASHER, PLAIN 6MM	1	
24	9430108140	PIN A, DOWEL 8 X 14	2	
25	957010602000	BOLT, FLANGE 6 X 20	3	
26	957010805000	BOLT, FLANGE 8 X 50	9	
27	9621112000	BALL, STEEL #12 (3/8)	1	
28	966000601600	BOLT, SOCKET 6 X 16	2	

# HONDA GX-670 — CRANKSHAFT ASSY.

CRANKSHAFT ASSY.



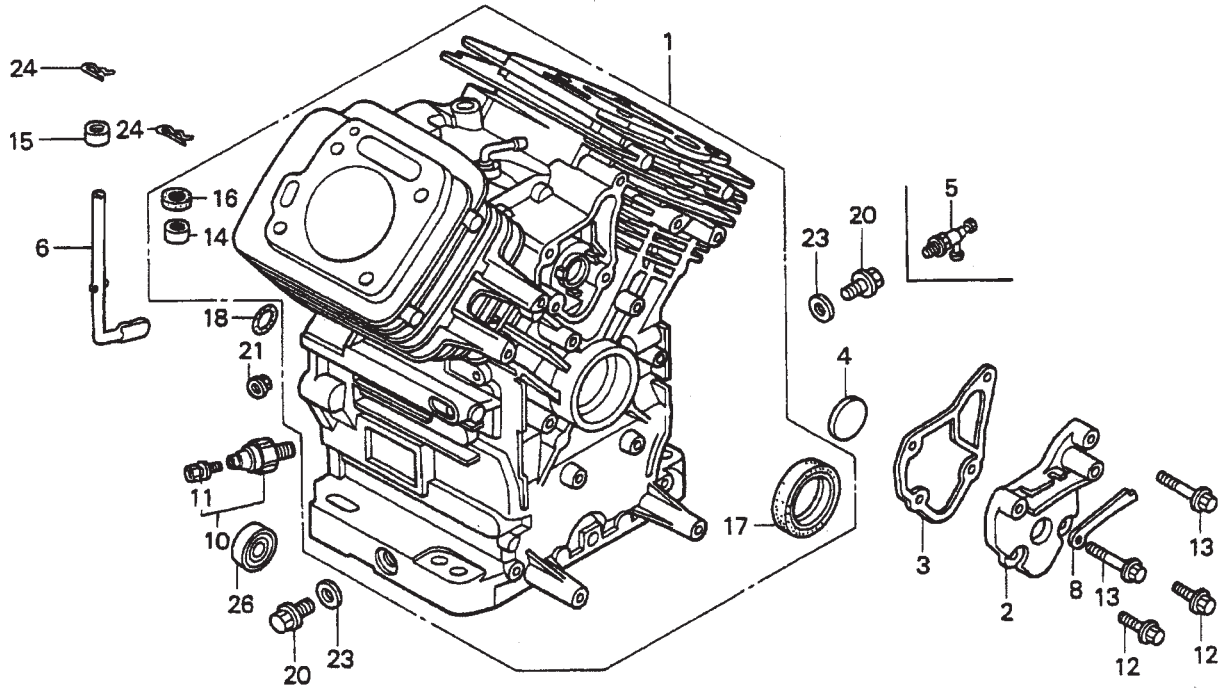
# HONDA GX-670 — CRANKSHAFT ASSY.

CRANKSHAFT ASSY.

<u>NO.</u>	<u>PART NO.</u>	<u>PART NAME</u>	<u>QTY.</u>	<u>REMARKS</u>
1	13310ZN1000	CRANKSHAFT COMP., T-TYPE	1	
3	90401ZJ1000	WASHER, CRANKSHAFT THRUST	1	

# HONDA GX-670 — CYLINDER BARREL ASSY.

CYLINDER BARRELA S S Y.



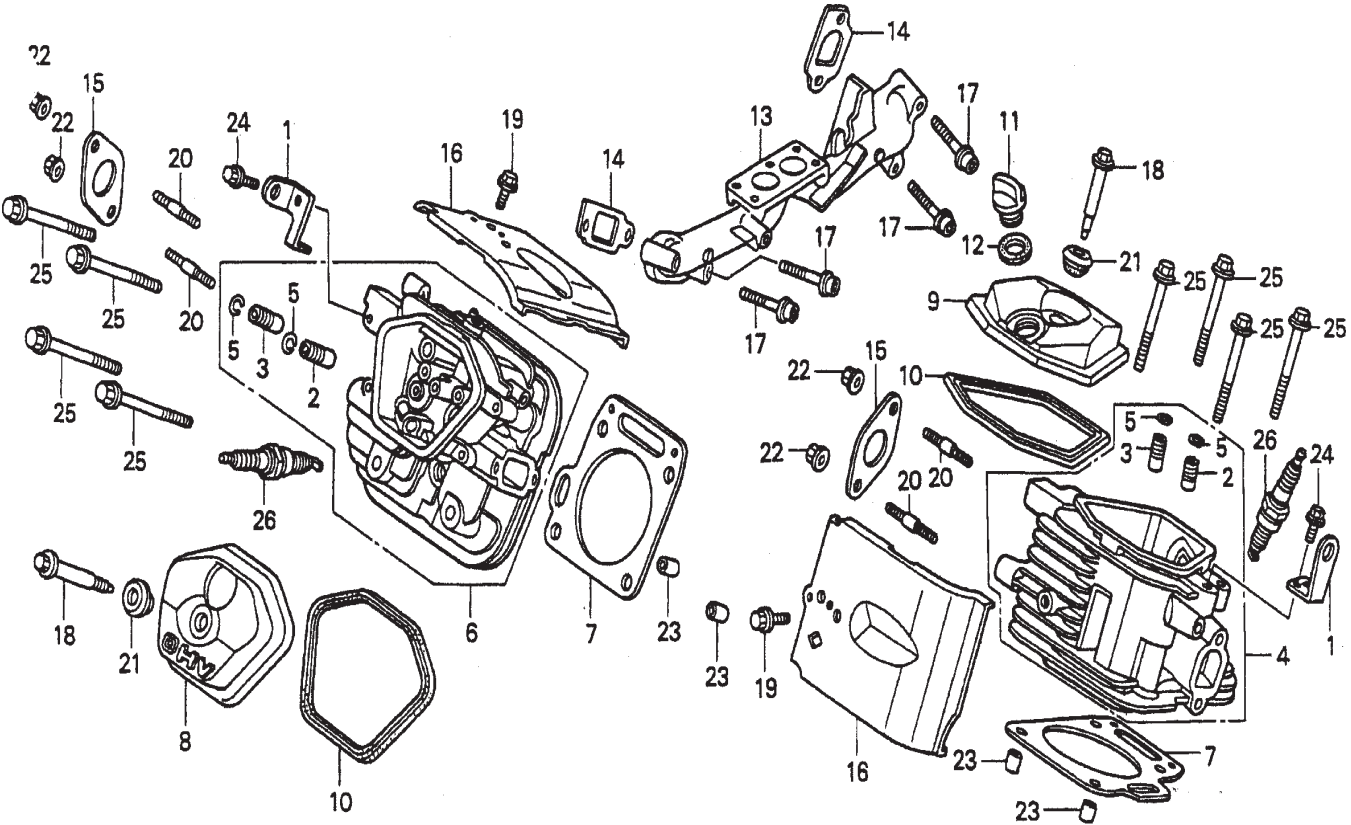
# HONDA GX-670 — CYLINDER BARREL ASSY.

## CYLINDER BARREL ASSY.

<u>NO.</u>	<u>PART NO.</u>	<u>PART NAME</u>	<u>QTY.</u>	<u>REMARKS</u>
1	12000ZN1010	CYLINDER ASSEMBLY .....	1	INCLUDES ITEMS W/*
2	12356ZJ1000	COVER, BREATHER	1	
3	12358ZJ1000	GASKET, BREATHER COVER	1	
4	12372ZE2300	VALVE, BREATHER	1	
5	15558ZJ010AH	VALVE, DRAIN 14 X 1.5 (OPTIONAL)	1	
6	16541ZJ1840	SHAFT, GOVERNOR ARM	1	
8	31511ZJ1000	CLAMP, WIRE	1	
10	37240ZG3E01	SWITCH, OIL PRESSURE	1	
11	90002ZG5004	SCREW- WASHER 4 X 8	1	
12	90029888000	BOLT, FLANGE 6 X 16	2	
13	90031ZE1000	BOLT, FLANGE 6 X 32	2	
14*	91001ZJ1841	BEARING, NEEDLE 8 X12.7 X 11.1	1	
15	91002ZJ1841	BEARING, NEEDLE 8 X12 X 10	1	
16*	91201ZE9003	OIL SEAL 8 X 14 X 5	1	
17*	91201ZJ1841	OIL SEAL 38 X 58 X 9	1	
18	91302MB6830	O- RING 13 X 3.0	1	
20	9280014000	BOLT, DRAIN PLUG 14MM	2	
21	9410208800	WASHER, PLAIN 8MM	3	
23	9410914000	WASHER, DRAIN PLUG 14MM	2	
24	9425108000	PIN, LOCK 8MM	2	
26	961406003010	BEARING, RADIAL BALL 6003	1	

# HONDA GX-670 — CYLINDER HEAD ASSY.

## CYLINDER HEAD ASSY.





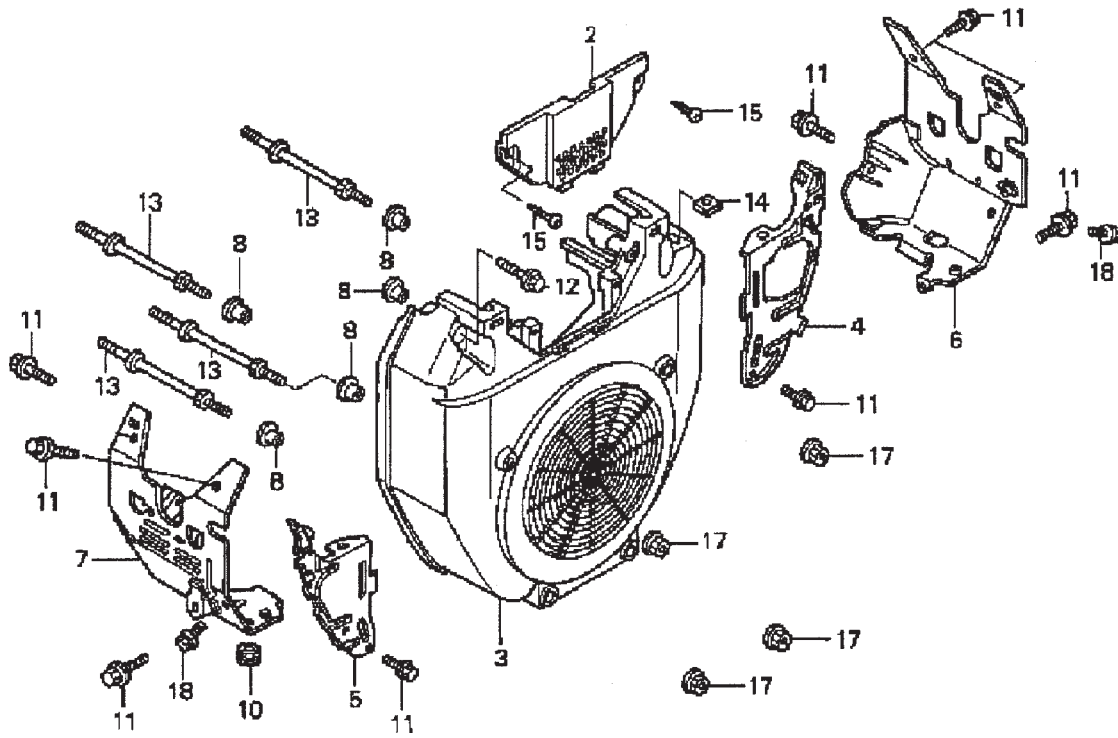
# HONDA GX-670 — CYLINDER HEAD ASSY.

## CYLINDER HEAD ASSY.

<u>NO.</u>	<u>PART NO.</u>	<u>PART NAME</u>	<u>QTY.</u>	<u>REMARKS</u>
1	11911ZJ1840	HANGER, ENGINE	2	
2*%	12204ZE2306	GUIDE, VALVE (OS), OPTIONAL	2	
3*%	12205ZJ1405	GUIDE, EX. VALVE (OS), OPTIONAL	2	
4	12210ZJ1840	CYLINDER HEAD COMP. #1 .....	1	INCLUDES ITEMS W/*
5*%	12216ZE2300	CLIP, VALVE GUIDE	4	
6	12220ZJ1840	CYLINDER HEAD COMP. #2 .....	1	INCLUDES ITEMS W/%
7	12251ZJ1841	GASKET, CYLINDER HEAD	2	
8	12311ZJ1840	COVER, HEAD	1	
9	12314ZJ1840	COVER, HEAD FILLER	1	
10	12391ZE2020	GASKET, CYLINDER HEAD COVER	2	
11	15611MB0000	CAP, OIL FILLER	1	
12	15625ZJ1840	GASKET, OIL FILLER CAP	1	
13	17101ZN1000	MANIFOLD, IN.	1	
14	17151ZJ1841	GASKET, IN. MANIFOLD	2	
15	18333ZE3800	GASKET, EX. PIPE	2	
16	19682ZJ1840	SHROUD, HEAD	2	
17	90011ZJ1841	BOLT, SOCKET 8 X 45	4	
18	90014ZE2000	BOLT, HEAD COVER	2	
19	90014952000	BOLT, FLANGE 6 X 14	2	
20	90018ZJ1840	BOLT, STUD 8 X 22	4	
21	90441ZE2010	WASHER COMP., HEAD COVER	2	
22	9405008000	NUT, FLANGE 8MM	4	
23	9430112200	PIN A, DOWEL 12 X 20	4	
24	957010802000	BOLT, FLANGE 8 X 20	2	
25	957011008000	BOLT, FLANGE 10 X 80	8	
26	9807952876	SPARK PLUG BPR2ES (OPTIONAL)	2	

# HONDA GX-670 — FAN COVER ASSY.

FAN COVER ASSY.



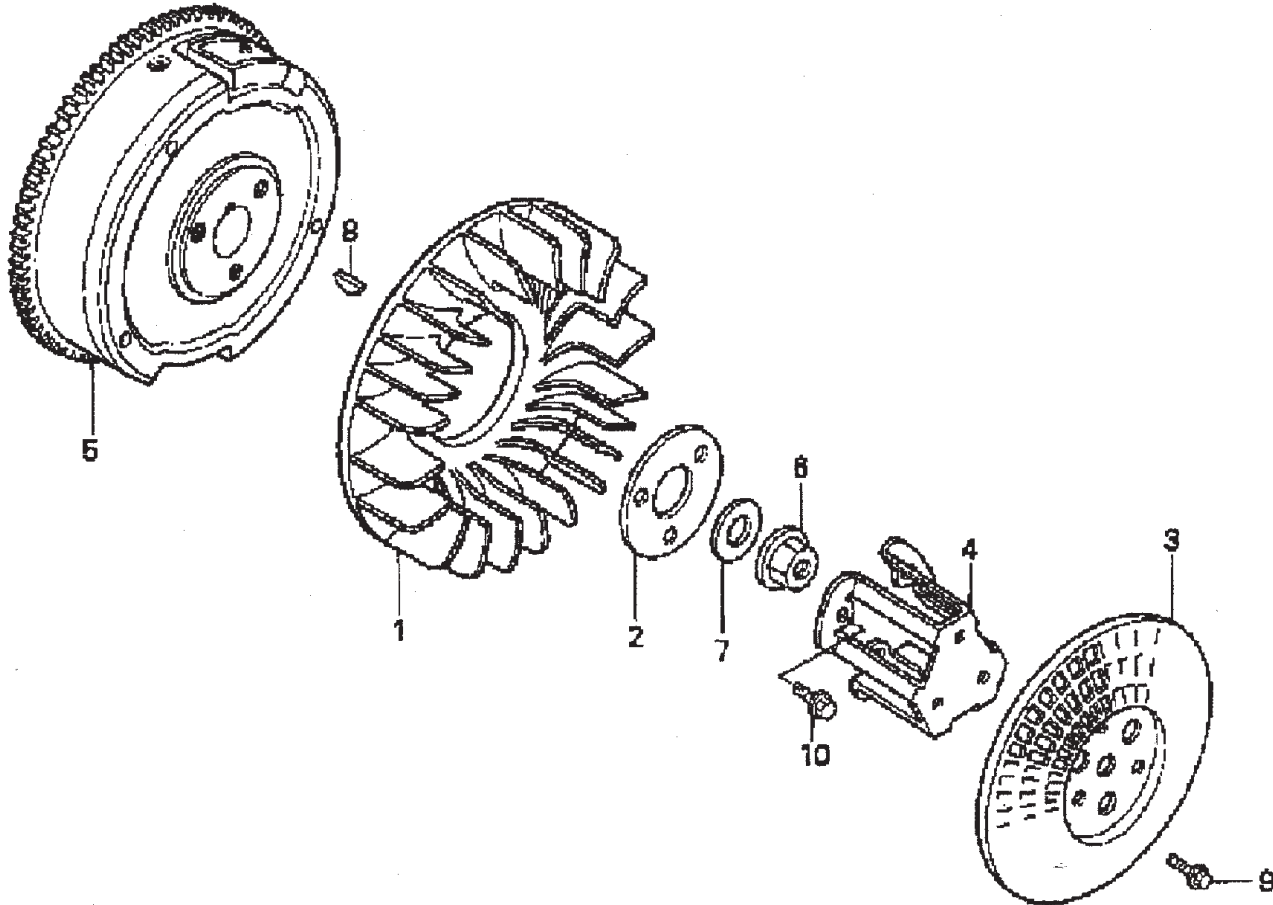
## HONDA GX-670 — FAN COVER ASSY.

### FAN COVER ASSY.

<u>NO.</u>	<u>PART NO.</u>	<u>PART NAME</u>	<u>QTY.</u>	<u>REMARKS</u>
2	16715ZJ1850	COVER, FUEL PUMP, MANUAL CONTROL	1	
3	19611ZJ1840ZA	COVER, FAN *NH1* (BLACK)	1	
4	19612ZJ1840	PLATE, RIGHT SIDE	1	
5	19614ZJ1840	PLATE, LEFT SIDE	1	
6	19631ZJ1840	SHROUD, RIGHT	1	
7	19632ZN1000	SHROUD, LEFT	1	
8	33713GC2000	COLLAR B, TAIL LIGHT	6	
10	80101310000	RUBBER, RR. FENDER CUSHION	1	
11	90013883000	BOLT, FLANGE 6 X 12 (CT200)	9	
12	90018ZE1000	BOLT, FLANGE 6 X 23	2	
13	90042ZJ1840	BOLT, STUD 6 X 71	4	
14	90313ZJ1840	NUT, SQUARE 5MM	2	
15	9391325580	SCREW, TAPPING 5 X 20	2	
17	9405006000	NUT, FLANGE 6MM	4	
18	957010600800	BOLT, FLANGE 6 X 8	2	

# HONDA GX-670 — FLYWHEEL ASSY.

FLY WHEEL ASSY.



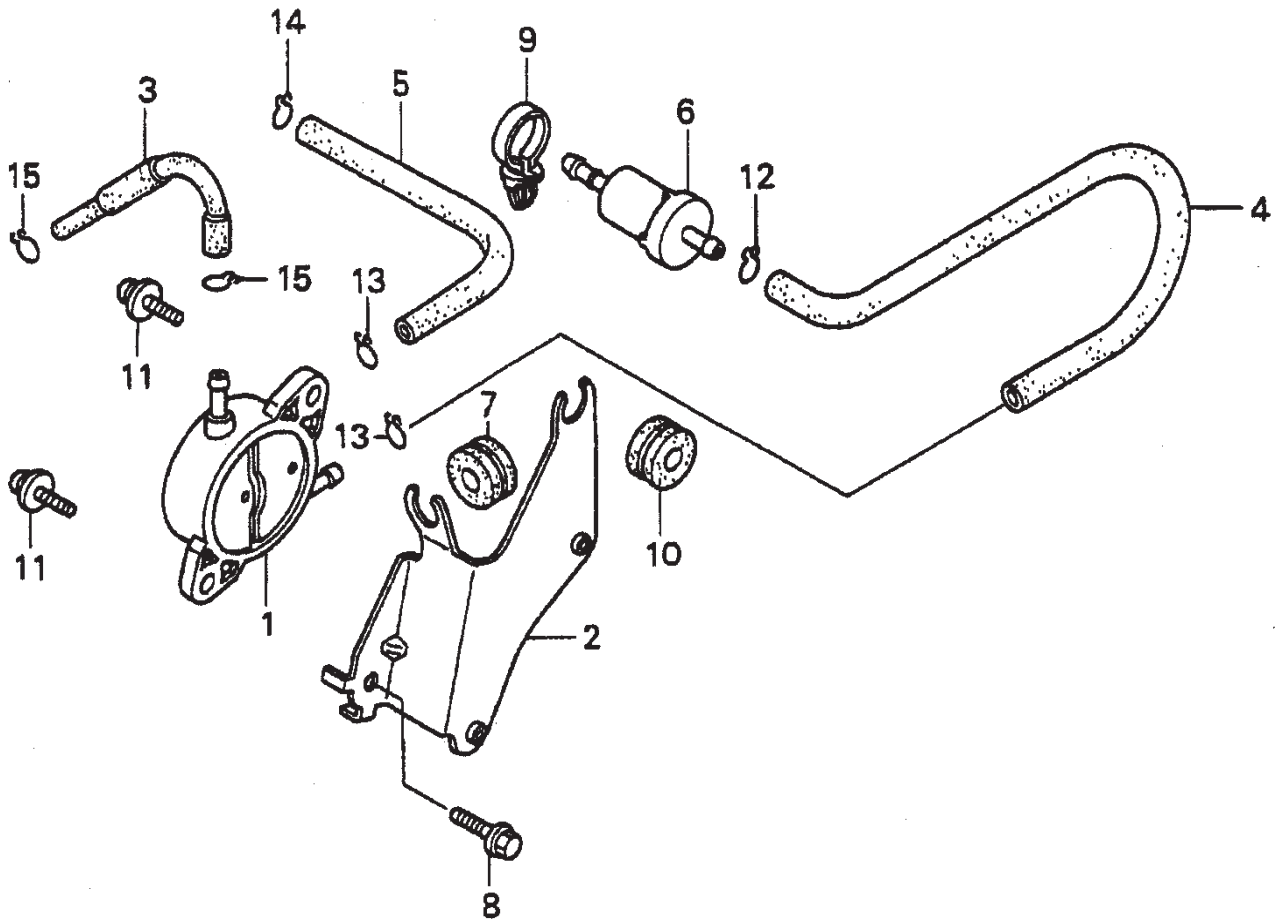
## HONDA GX-670 — FLYWHEEL ASSY.

### FLY WHEEL ASSY.

<u>NO.</u>	<u>PART NO.</u>	<u>PART NAME</u>	<u>QTY.</u>	<u>REMARKS</u>
1	19511ZJ1000	FAN, COOLING	1	
2	19513ZJ1000	PLATE, COOLING FAN SETTING	1	
3	28452ZJ1811	GRID, SCREEN P.T.O. (OPTIONAL)	1	
4	28454ZJ1801	HOLDER, SCREEN GRID, OPTIONAL	1	
5	31110ZJ1840	FLY WHEEL COMP.	1	
6	90201ZG3000	NUT, FLANGE 20MM	1	
7	90401ZG3000	WASHER 20MM	1	
8	90741ZE2000	KEY, SPECIAL WOODRUFF 25 X 18	1	
9	957010601200	BOLT, FLANGE 6 X 12 (OPTIONAL)	3	
10	957010801600	BOLT, FLANGE 8 X 16	3	

# HONDA GX-670 — FUEL PUMP ASSY.

FUEL PUMP ASSY.



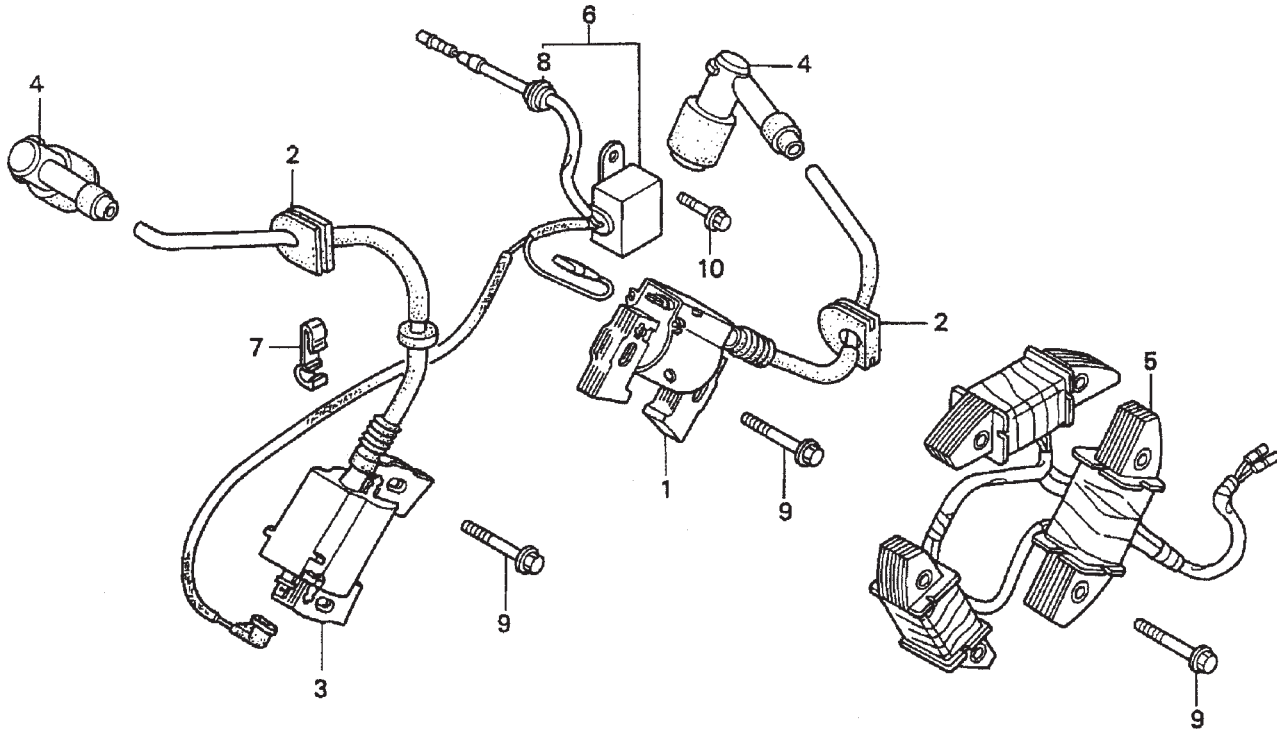
## HONDA GX-670 — FUEL PUMP ASSY.

### FUEL PUMP ASSY.

<u>NO.</u>	<u>PART NO.</u>	<u>PART NAME</u>	<u>QTY.</u>	<u>REMARKS</u>
1	16700ZL8003	PUMP ASSEMBLY, FUEL	1	
2	16711ZJ1840	STAY, FUEL PUMP	1	
3	16851ZN1000	TUBE, FUEL	1	
4	16852ZJ1840	TUBE B, FUEL	1	
5	16882ZJ1840	TUBE, DIAPHRAGM	1	
6	16910ZE8015	FILTER COMP., FUEL	1	
7	19111MF5000	GROMMET, RESERVE TANK	1	
8	90014952000	BOLT, FLANGE 6 X 14	1	
9	90517SA0003	CLIP, WIRE HARNESS	1	
10	91601ZJ1840	GROMMET, PUMP STAY	1	
11	938940601600	SCREW- WASHER 6 X 16	2	
12	9500202080	CLIP,TUBE B8	1	
13	9500202100	CLIP, TUBE B10	2	
14	9500250000	CLIP, TUBE C9	1	
15	9500270000	CLIP, TUBE C11	2	

# HONDA GX-670 — IGNITION COIL ASSY.

IGNITION COIL ASSY.





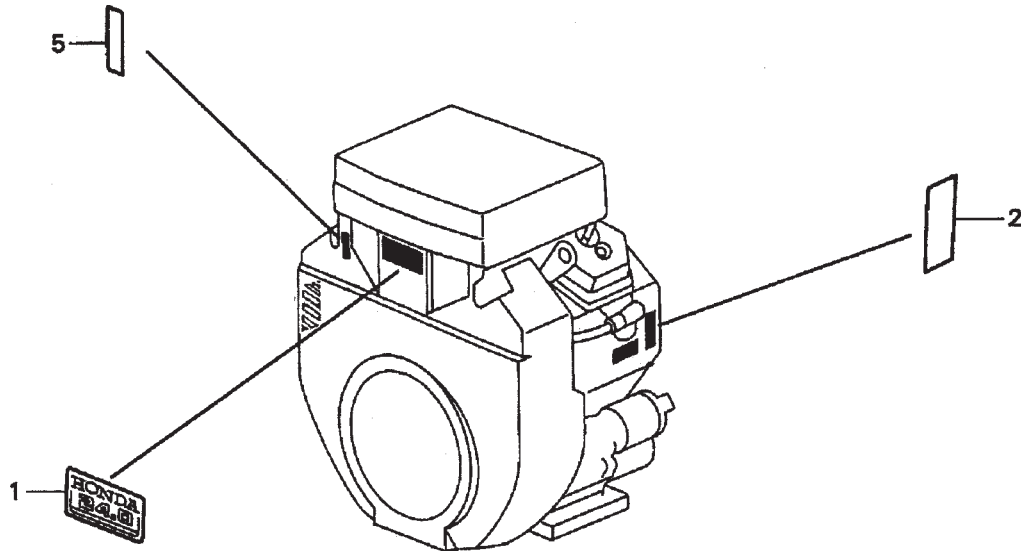
# HONDA GX-670 — IGNITION COIL ASSY.

## IGNITION COIL ASSY.

<u>NO.</u>	<u>PART NO.</u>	<u>PART NAME</u>	<u>QTY.</u>	<u>REMARKS</u>
1	30500ZJ1841	COIL ASSEMBLY R. IGNITION	1	
2	30518ZJ1000	GROMMET, IGNITION WIRE	2	
3	30550ZJ1841	COIL ASSEMBLY, L.. IGNITION	1	
4	30700ZJ1841	CAP ASSEMBLY, NOISE SUPPRESSOR	2	
5	31630ZJ1801	COIL ASSEMBLY, CHARGE 12V/20A	1	
6	31740ZJ1841	DIODE ASSEMBLY, ENGINE STOP .....	1	INCLUDES ITEMS W/*
7	32763PA0000	CLAMP, WIRE	1	
8*	63312ZA7000	GROMMET, TOOL	1	
9	90031ZE1000	BOLT, FLANGE 6 X 32	8	
10	957010600800	BOLT, FLANGE 6 X 8	1	

# HONDA GX-670 — LABELS ASSY.

LABELS ASSY.



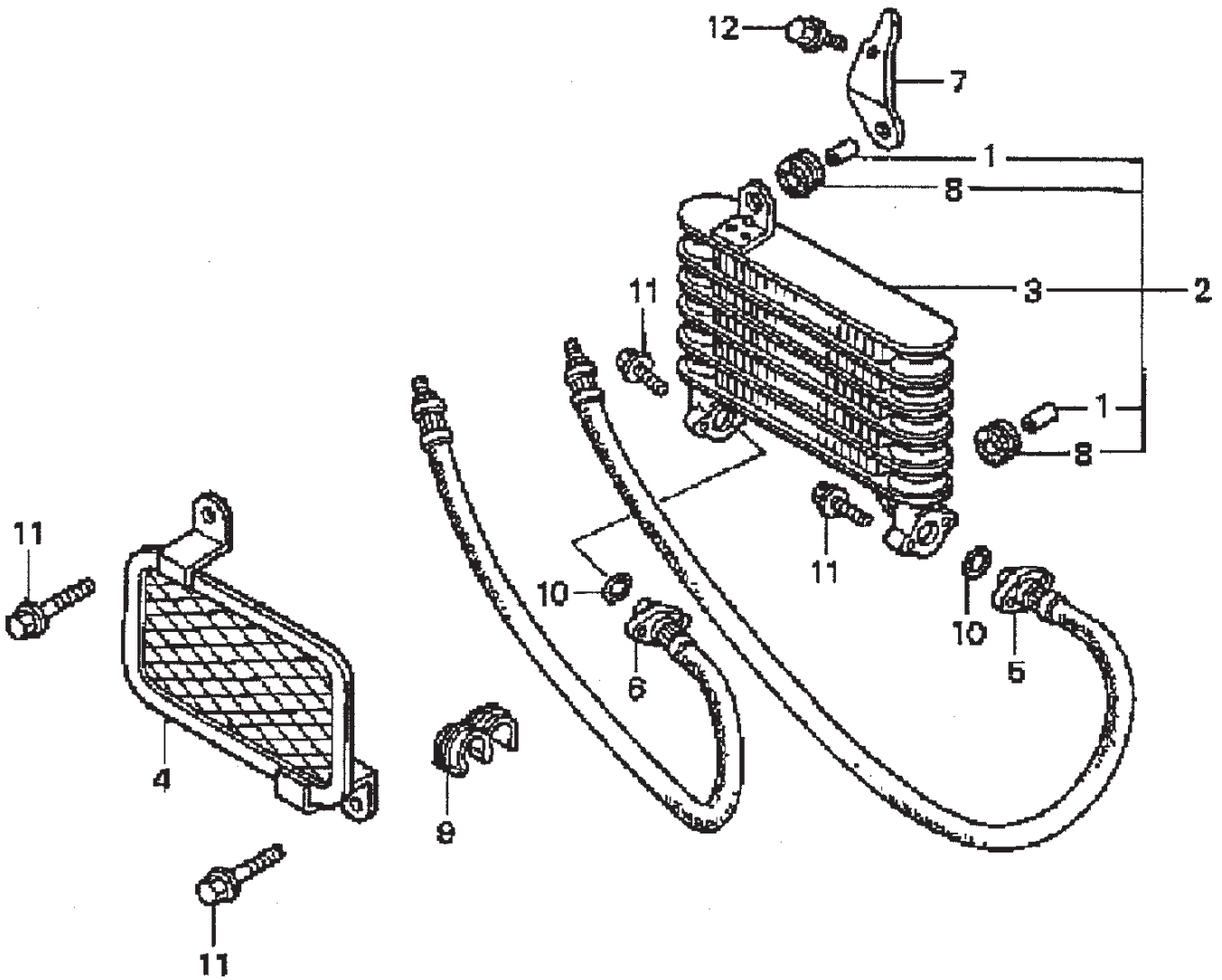
## HONDA GX-670 — LABELS ASSY.

LABELS ASSY.

<u>NO.</u>	<u>PART NO.</u>	<u>PART NAME</u>	<u>QTY.</u>	<u>REMARKS</u>
1	87101ZN1000	MARK, EMBLEM	1	
2	87152ZN1000	LABEL, SPECIFICATION G X 670	1	
5	87532ZJ1840	MARK, THROTTLE INDICATION	1	

# HONDA GX-670 — OIL COOLER ASSY.

OIL COOLER ASSY.



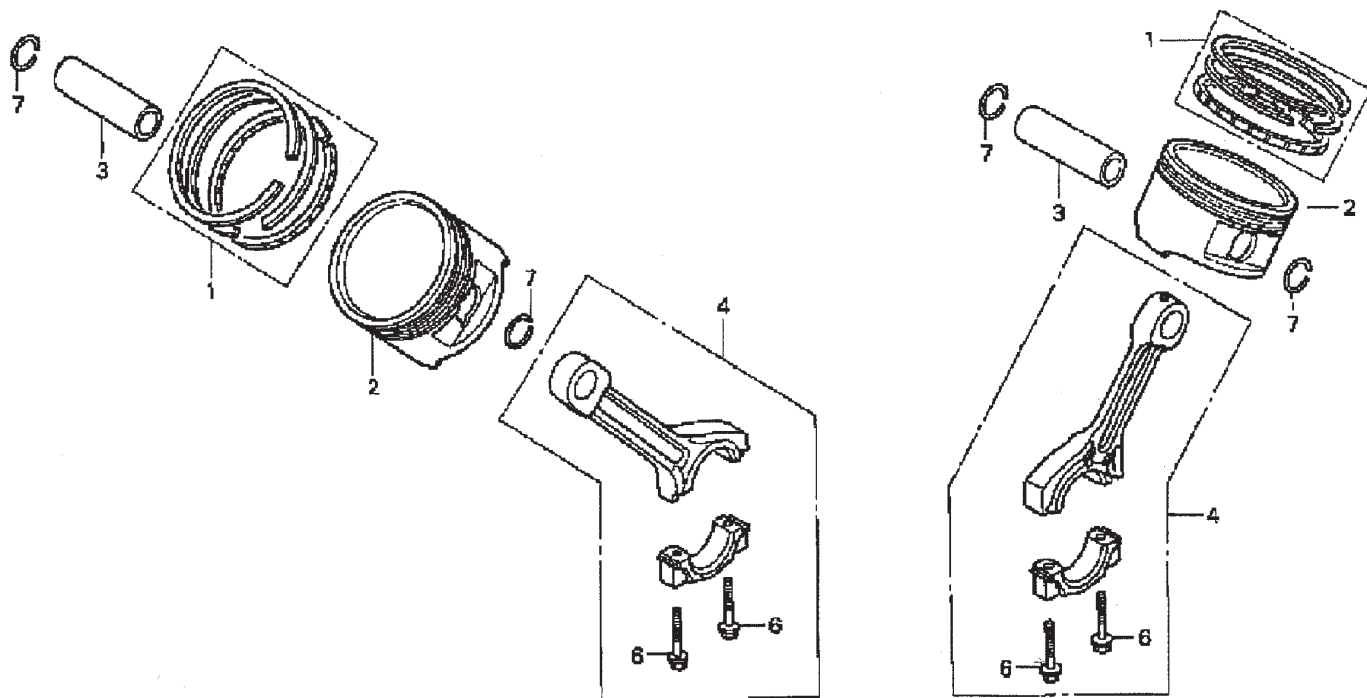
# HONDA GX-670 — OIL COOLER ASSY.

OIL COOLER ASSY.

<u>NO.</u>	<u>PART NO.</u>	<u>PART NAME</u>	<u>QTY.</u>	<u>REMARKS</u>
1*	11513MN5300	COLLAR 12MM	2	
2	15605ZN1000	COOLER ASSEMBLY, OIL .....	1	INCLUDES ITEMS W/*
3*	15610ZN1000	COOLER COMP., OIL	1	
4	15613ZN1000	GRILLE, OIL COOLER	1	
5	15614ZN1003	HOSE A, OIL	1	
6	15616ZN1003	HOSE B, OIL	1	
7	15676ZN1000	STAY, OIL COOLER	1	
8*	19051KA3830	RUBBER, RADIATOR MOUNTING	2	
9	19314PH6000	CLAMP, HOSE D13.5	1	
10	91314ME5003	O- RING 10 X 2.6	2	
11	957010602200	BOLT, FLANGE 6 X 22	6	
12	90014952000	BOLT, FLANGE 6 X 14	1	

# HONDA GX-670 — PISTON + CONNECTING ROD ASSY.

PISTON + CONNECTING ROD ASSY.



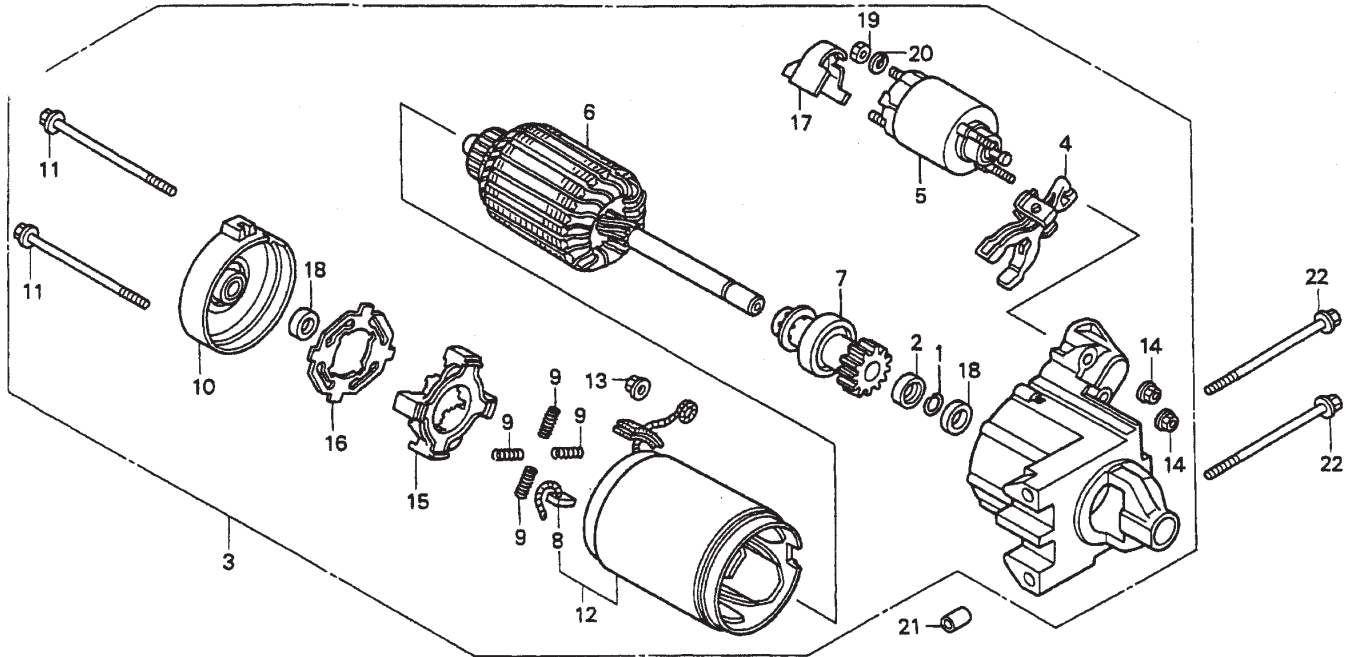
## HONDA GX-670 — PISTON + CONNECTING ROD ASSY.

### PISTON + CONNECTING ROD ASSY.

<u>NO.</u>	<u>PART NO.</u>	<u>PART NAME</u>	<u>QTY.</u>	<u>REMARKS</u>
1	13010ZJ1841	RING SET, PISTON STD.	2	
1	13011ZJ1841	RING SET, PISTON OS 0.25 (OPTIONAL)	2	
1	13012ZJ1841	RING SET, PISTON OS 0.50 (OPTIONAL)	2	
1	13013ZJ1841	RING SET, PISTON 0.75 (OPTIONAL)	2	
2	13101ZN1000	PISTON STD.	2	
2	13102ZN1000	PISTON OS 0.25 (OPOTIONAL)	2	
2	13103ZN1000	PISTON OS 0.50 (OPTIONAL)	2	
2	13104ZN1000	PISTON 0.75 (OPTIONAL)	2	
3	13111ZJ1840	PIN, PISTON	2	
4	13200ZN1003	ROD ASSEMBLY CONNECTING	2	
6	90001ZN1000	BOLT, CONNECTING ROD 6 X 37	4	
7	9460118000	CLIP, PISTON PIN 18MM	4	

# HONDA GX-670 — STARTER MOTOR ASSY.

STARTER MOTOR ASSY.





# HONDA GX-670 — STARTER MOTOR ASSY.

## STARTER MOTOR ASSY.

<u>NO.</u>	<u>PART NO.</u>	<u>PART NAME</u>	<u>QTY.</u>	<u>REMARKS</u>
1*	30201PH9004	RING, SNAP (DENSO)	1	
2*	30202PZ1003	COLLAR SET, CLUTCH STOP	1	
3	31200ZJ1841	MOTOR ASSEMBLY STARTER .....	1	INCLUDES ITEMS W/*
4*	31203PH9004	LEVER, PINION DRIVE	1	
5*	31204ZJ1H01	SWITCH ASSEMBLY, MAGNET	1	
6*	31206ZG4801	ARMATURE COMP.	1	
7*	31207ZJ1H01	CLUTCH COMP., OVERRUNNING	1	
8*	31211PH9004	BRUSH	4	
9*	31212PH9004	SPRING, BRUSH	4	
10*	31213P64N01	COVER	1	
11*	31214PH9004	BOLT, THROUGH	2	
12*	31216ZJ1H01	YOKE COMP.	1	
13*	31220PH9004	NUT, HEX 8MM	1	
14*	31223PA0006	NUT, FLANGE 5MM	2	
15*	31231PH9004	HOLDER, BRUSH	1	
16*	31233PH9004	INSULATOR, BRUSH HOLDER	1	
17*	31234ZJ1H01	COVER, TERMINAL	1	
18*	91002ZG4801	BEARING A	2	
19*	94001080000S	NUT, HEX 8MM	1	
20*	9411108000	WASHER, SPRING 8MM	1	
21	9430110120	PIN, DOWEL 10 X 12	2	
22	957010811000	BOLT, FLANGE 8 X 110	2	

# TERMS AND CONDITIONS OF SALE — PARTS

## PAYMENT TERMS

Terms of payment for parts are net 30 days.

## FREIGHT POLICY

All parts orders will be shipped collect or prepaid with the charges added to the invoice. All shipments are F.O.B. point of origin. Multiquip's responsibility ceases when a signed manifest has been obtained from the carrier, and any claim for shortage or damage must be settled between the consignee and the carrier.

## MINIMUM ORDER

The minimum charge for orders from Multiquip is \$15.00 net. Customers will be asked for instructions regarding handling of orders not meeting this requirement.

## RETURNED GOODS POLICY

Return shipments will be accepted and credit will be allowed, subject to the following provisions:

1. A Returned Material Authorization must be approved by Multiquip prior to shipment.
2. To obtain a Return Material Authorization, a list must be provided to Multiquip Parts Sales that defines item numbers, quantities, and descriptions of the items to be returned.
  - a. The parts numbers and descriptions must match the current parts price list.
  - b. The list must be typed or computer generated.
  - c. The list must state the reason(s) for the return.
  - d. The list must reference the sales order(s) or invoice(s) under which the items were originally purchased.
  - e. The list must include the name and phone number of the person requesting the RMA.
3. A copy of the Return Material Authorization must accompany the return shipment.
4. Freight is at the sender's expense. All parts must be returned freight prepaid to Multiquip's designated receiving point.

5. Parts must be in new and resalable condition, in the original Multiquip package (if any), and with Multiquip part numbers clearly marked.
6. The following items are not returnable:
  - a. Obsolete parts. (If an item is in the price book and shows as being replaced by another item, it is obsolete.)
  - b. Any parts with a limited shelf life (such as gaskets, seals, "O" rings, and other rubber parts) that were purchased more than six months prior to the return date.
  - c. Any line item with an extended dealer net price of less than \$5.00.
  - d. Special order items.
  - e. Electrical components.
  - f. Paint, chemicals, and lubricants.
  - g. Decals and paper products.
  - h. Items purchased in kits.
7. The sender will be notified of any material received that is not acceptable.
8. Such material will be held for five working days from notification, pending instructions. If a reply is not received within five days, the material will be returned to the sender at his expense.
9. Credit on returned parts will be issued at dealer net price at time of the original purchase, less a 15% restocking charge.
10. In cases where an item is accepted, for which the original purchase document can not be determined, the price will be based on the list price that was effective twelve months prior to the RMA date.
11. Credit issued will be applied to future purchases only.

## PRICING AND REBATES

Prices are subject to change without prior notice. Price changes are effective on a specific date and all orders received on or after that date will be billed at the revised price. Rebates for price declines and added charges for price increases will not be made for stock on hand at the time of any price change.

Multiquip reserves the right to quote and sell direct to Government agencies, and to Original Equipment Manufacturer accounts who use our products as integral parts of their own products.

## SPECIAL EXPEDITING SERVICE

A \$35.00 surcharge will be added to the invoice for special handling including bus shipments, insured parcel post or in cases where Multiquip must personally deliver the parts to the carrier.

## LIMITATIONS OF SELLER'S LIABILITY

Multiquip shall not be liable hereunder for damages in excess of the purchase price of the item with respect to which damages are claimed, and in no event shall Multiquip be liable for loss of profit or good will or for any other special, consequential or incidental damages.

## LIMITATION OF WARRANTIES

No warranties, express or implied, are made in connection with the sale of parts or trade accessories nor as to any engine not manufactured by Multiquip. Such warranties made in connection with the sale of new, complete units are made exclusively by a statement of warranty packaged with such units, and Multiquip neither assumes nor authorizes any person to assume for it any other obligation or liability whatever in connection with the sale of its products. Apart from such written statement of warranty, there are no warranties, express, implied or statutory, which extend beyond the description of the products on the face hereof.

Effective: February 22, 2006



# OPERATION AND PARTS MANUAL

## HERE'S HOW TO GET HELP

PLEASE HAVE THE MODEL AND SERIAL  
NUMBER *ON-HAND* WHEN CALLING

### UNITED STATES

#### ***Multiquip Corporate Office***

18910 Wilmington Ave. Tel. (800) 421-1244  
Carson, CA 90746 Fax (800) 537-3927  
Contact: mq@multiquip.com

#### ***Mayco Parts***

800-306-2926 Fax: 800-672-7877  
310-537-3700 Fax: 310-637-3284

#### ***Service Department***

800-421-1244 Fax: 310-537-4259  
310-537-3700

#### ***MQ Parts Department***

800-427-1244 Fax: 800-672-7877  
310-537-3700 Fax: 310-637-3284

#### ***Warranty Department***

800-421-1244, Ext. 279 Fax: 310-537-1173  
310-537-3700, Ext. 279

#### ***Technical Assistance***

800-478-1244 Fax: 310-631-5032

### MEXICO

#### ***MQ Cipsa***

Carr. Fed. Mexico-Puebla KM 126.5 Tel: (52) 222-225-9900  
Momoxpan, Cholula, Puebla 72760 Mexico Fax: (52) 222-285-0420  
Contact: pmastretta@cipsa.com.mx

### CANADA

#### ***Multiquip***

4110 Industriel Boul. Tel: (450) 625-2244  
Laval, Quebec, Canada H7L 6V3 Fax: (450) 625-8664  
Contact: jmartin@multiquip.com

### UNITED KINGDOM

#### ***Multiquip (UK) Limited Head Office***

Hanover Mill, Fitzroy Street, Tel: 0161 339 2223  
Ashton-under-Lyne, Fax: 0161 339 3226  
Lancashire OL7 0TL  
Contact: sales@multiquip.co.uk

### BRAZIL

#### ***Multiquip***

Av. Evandro Lins e Silva, 840 - grupo 505 Tel: 011-55-21-3433-9055  
Barra de Tijuca - Rio de Janeiro Fax: 011-55-21-3433-9055  
Contact: cnavarro@multiquip.com.br, srentes@multiquip.com.br

© COPYRIGHT 2007, MULTIQUIP INC.

Multiquip Inc, the MQ logo and the Whiteman logo are registered trademarks of Multiquip Inc. and may not be used, reproduced, or altered without written permission. All other trademarks are the property of their respective owners and used with permission.

This manual MUST accompany the equipment at all times. This manual is considered a permanent part of the equipment and should remain with the unit if resold.

The information and specifications included in this publication were in effect at the time of approval for printing. Illustrations, descriptions, references and technical data contained in this manual are for guidance only and may not be considered as binding. Multiquip Inc. reserves the right to discontinue or change specifications, design or the information published in this publication at any time without notice and without incurring any obligations.

Your Local Dealer is:

