

PARTS MANUAL



MAYCO
MODEL LS600P
CONCRETE PUMP
(PERKINS 1104D-44TA DIESEL ENGINE)

Revision #5 (03/30/26)

To find the latest revision of this publication or associated operation manual, visit our website at: www.multiquip.com



THIS MANUAL MUST ACCOMPANY THE EQUIPMENT AT ALL TIMES.

TABLE OF CONTENTS

LS600P Concrete Pump

Explanation of Code in Remarks Column.....	4
Suggested Spare Parts	5

Component Drawings

Nameplate and Decals Assembly.....	6–9
Frame Assembly.....	10–11
Axle/Brake Line and Light Assembly	12–13
Trailer Hitch Assembly	14–15
Battery Box Assembly.....	16–17
Hopper Assembly	18–19
Hopper Attachment Assembly	20–21
Hopper Interior Assembly	22–23
Shuttle Cylinder Assembly.....	24–25
Lubrication Pistons Assembly.....	26–29
Fuel Tank Assembly.....	30–31
Heat Exchanger Assembly	32–33

Accumulator Assembly	34–35
Remixer Control Assembly	36–37
Lubrication Panel Assembly	38–39
Engine Cover Assembly	40–41
Hydraulic Tank Assembly.....	42–43
Engine Mounting Exhaust Assembly	44–45
Engine Air Filter Assembly.....	46–47
Throttle Assembly	48–49
Oil Filter-Water Separator Assembly	50–51
Hydraulic Pump Assembly.....	52–53
Manifold Assembly.....	54–55
Control Box Assembly	56–57
Control Box Harness Assembly.....	58–59
Remote Control Cable Assembly.....	60–61
Hydraulic Stabilizer Assembly (Optional).....	62–63
Fuel-Water Separator Assembly.....	64–65
Fuses and Relays Assembly	66–67

NOTICE

Specifications and part numbers are subject to change without notice.

EXPLANATION OF CODE IN REMARKS COLUMN

The following section explains the different symbols and remarks used in the Parts section of this manual. Use the help numbers found on the back page of the manual if there are any questions.

NOTICE

The contents and part numbers listed in the parts section are subject to change without notice. Multiquip does not guarantee the availability of the parts listed.

SAMPLE PARTS LIST

NO.	PART NO.	PART NAME	QTY.	REMARKS
1	12345	BOLT	1	INCLUDES ITEMS W/%
2%		WASHER, 1/4 IN.		NOT SOLD SEPARATELY
2%	12347	WASHER, 3/8 IN. ...	1	MQ-45T ONLY
3	12348	HOSE	A/R	MAKE LOCALLY
4	12349	BEARING	1	S/N 2345B AND ABOVE

NO. Column

Unique Symbols — All items with same unique symbol (@, #, +, %, or >) in the number column belong to the same assembly or kit, which is indicated by a note in the “Remarks” column.

Duplicate Item Numbers — Duplicate numbers indicate multiple part numbers, which are in effect for the same general item, such as different size saw blade guards in use or a part that has been updated on newer versions of the same machine.

NOTICE

When ordering a part that has more than one item number listed, check the remarks column for help in determining the proper part to order.

PART NO. Column

Numbers Used — Part numbers can be indicated by a number, a blank entry, or TBD.

TBD (To Be Determined) is generally used to show a part that has not been assigned a formal part number at the time of publication.

A blank entry generally indicates that the item is not sold separately or is not sold by Multiquip. Other entries will be clarified in the “Remarks” Column.

QTY. Column

Numbers Used — Item quantity can be indicated by a number, a blank entry, or A/R.

A/R (As Required) is generally used for hoses or other parts that are sold in bulk and cut to length.

A blank entry generally indicates that the item is not sold separately. Other entries will be clarified in the “Remarks” Column.

REMARKS Column

Some of the most common notes found in the “Remarks” Column are listed below. Other additional notes needed to describe the item can also be shown.

Assembly/Kit — All items on the parts list with the same unique symbol will be included when this item is purchased.

Indicated by:

“INCLUDES ITEMS W/(unique symbol)”

Serial Number Break — Used to list an effective serial number range where a particular part is used.

Indicated by:

“S/N XXXXX AND BELOW”

“S/N XXXX AND ABOVE”

“S/N XXXX TO S/N XXX”

Specific Model Number Use — Indicates that the part is used only with the specific model number or model number variant listed. It can also be used to show a part is NOT used on a specific model or model number variant.

Indicated by:

“XXXXX ONLY”

“NOT USED ON XXXX”

“Make/Obtain Locally” — Indicates that the part can be purchased at any hardware shop or made out of available items. Examples include battery cables, shims, and certain washers and nuts.

“Not Sold Separately” — Indicates that an item cannot be purchased as a separate item and is either part of an assembly/kit that can be purchased, or is not available for sale through Multiquip.

SUGGESTED SPARE PARTS

MAYCO SERIES LS600P CONCRETE PUMP

LS600P CONCRETE PUMP

1 TO 3 UNITS

Qty.	P/N	Description
3	EM20763	FILTER, FUEL IN-LINE
3	EM167472	FILTER, WATER SEPARATOR
2	EM98206K	KEY, IGNITION SWITCH
1	515848	CIRCUIT BREAKER, 50 AMP
1	23284-300	FUSE, 30 AMP ATC/ATO
1	EM802378	RELAY, 40 AMP, FAN
1	EM802515	RELAY, 80 AMP, ENGINE PRE-HEAT
1	EM98163	SWITCH, PROXIMITY W/ CABLE
1	34507	FUEL CAP W/GAUGE
1	EM16462	RING AND FELT HOLDER
4	EM98050	CUP PISTON-ORANGE
4	EM16493	RING, FELT
2	EM14408	RING, BRONZE
2	EM16145A	BUSHING, SWING AXLE BRONZE
1	EM168161A	RING, ENERGIZER, RUBBER
1	EM168162	RING, STEEL, INSERT
2	EM98065	SEAL, GROOVED, RUBBER
1	EM98022	RING, WEAR
2	EM14407	O-RING, OILER PLATE
1	EM98021A	WEAR PLATE
2	EM517700	O-RING, WEAR PLATE
1	EM98033	OILER PLATE W/HOLES

PERKINS 1104D-44TA DIESEL ENGINE

1 to 3 units

Qty.	P/N	Description
3	2654407	OIL FILTER
3	62510380	AIR FILTER
3	26560201	FILTER, FUEL/WATER SEPARATOR
1	2656F837	BOWL, PLASTIC FUEL/WATER SEPARATOR

NOTICE

Part numbers on this Suggested Spare Parts list may supersede/replace the part numbers shown in the following parts lists.

NAMEPLATE AND DECALS ASSY.

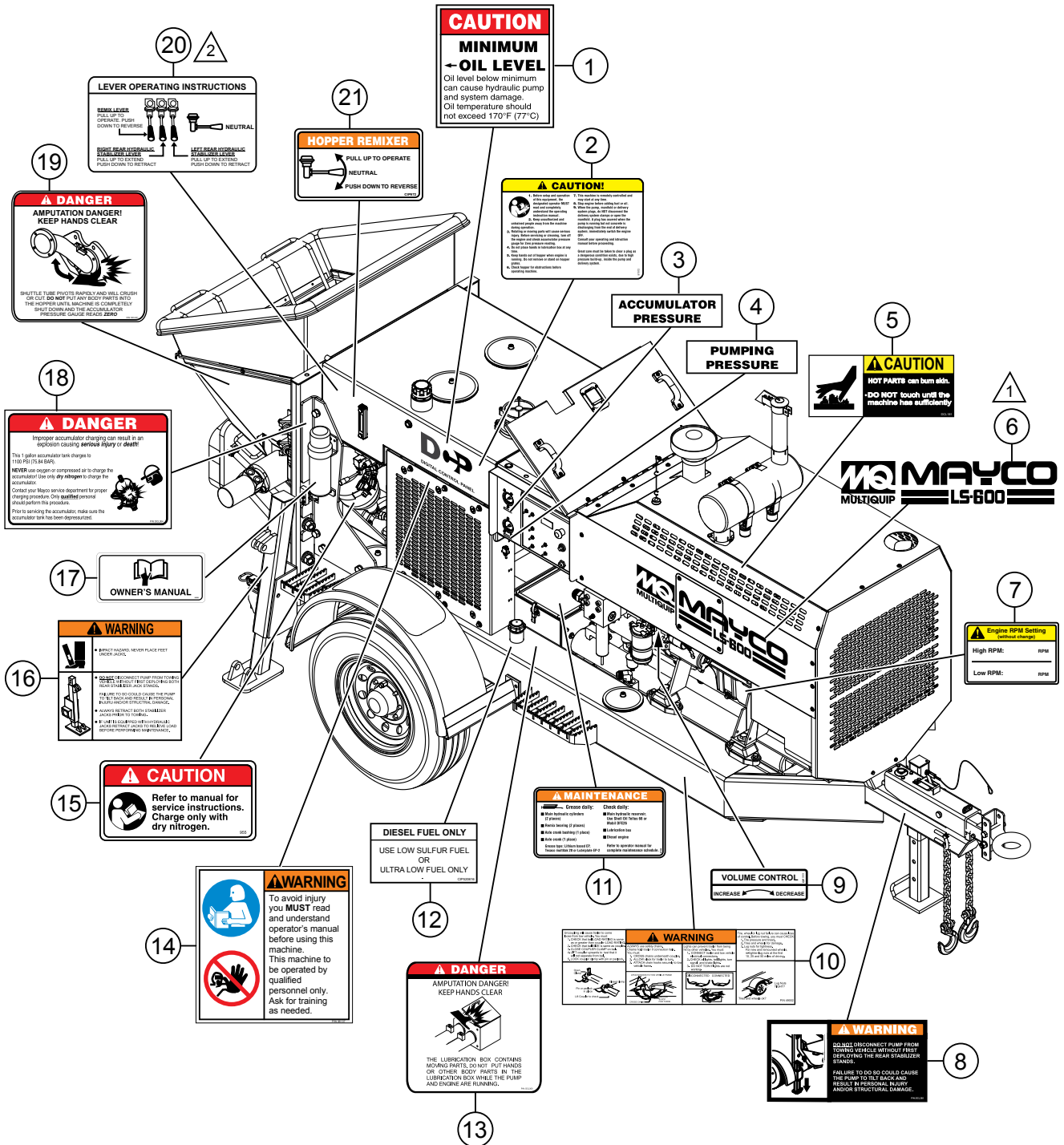

NOTES:

- ① PLACE DECAL ON LS600 MODELS ONLY.
- ② USE THIS DECAL (OPTION) WHEN HYDRAULIC STABILIZER JACKS ARE INSTALLED.

NAMEPLATE AND DECALS ASSY.

<u>NO.</u>	<u>PART NO.</u>	<u>PART NAME</u>	<u>QTY.</u>	<u>REMARKS</u>
1	EM511901	DECAL, CAUTION MINIMUM OIL LEVEL	1	
2	EM97072	DECAL, CAUTION OPERATIONS INSTRUCT.	1	
3%	EM97070	DECAL, ACCUMULATOR PRESSURE	1.....	INCLUDES ITEM W/\$
4\$	EM97070	DECAL, PUMPING PRESSURE	1.....	INCLUDES ITEM W/%
5	DCL302	DECAL, WARNING BURN HAZARD	1	
6	EM517644	DECAL, MQ/MAYCO LS600 LOGO	1	
7	513580	DECAL, ENGINE RPM SETTING	1	
8	DCL305	DECAL, WARNING REAR STABILIZERS	1	
9	EM985	DECAL, VOLUMN CONTROL	1	
10	34627	DECAL, TOWING, WARNING	1	
11	EM97084	DECAL, MAINTENANCE	1	
12	EM995	DECAL, CAUTION DIESEL FUEL	1	
13	DCL300	DECAL, LUBRICATION BOX	1	
14	35137	DECAL, CAUTION READ MANUAL	1	
15	EM955	DECAL, CAUTION DRY NITROGEN	1	
16	518090	DECAL, WARNING IMPACT HAZARD	1	
17	34536	DECAL, OWNER'S MANUAL	1	
18	DCL304	DECAL, DANGER IMPROPER CHARGING	1	
19	DCL301	DECAL, DANGER SHUTTLE TUBE	1	
20	518091	DECAL, LEVER OPERATING INSTRUCT.	1	
21	EM970	DECAL, HOPPER REMIXER	1	

NAMEPLATE AND DECALS ASSY.

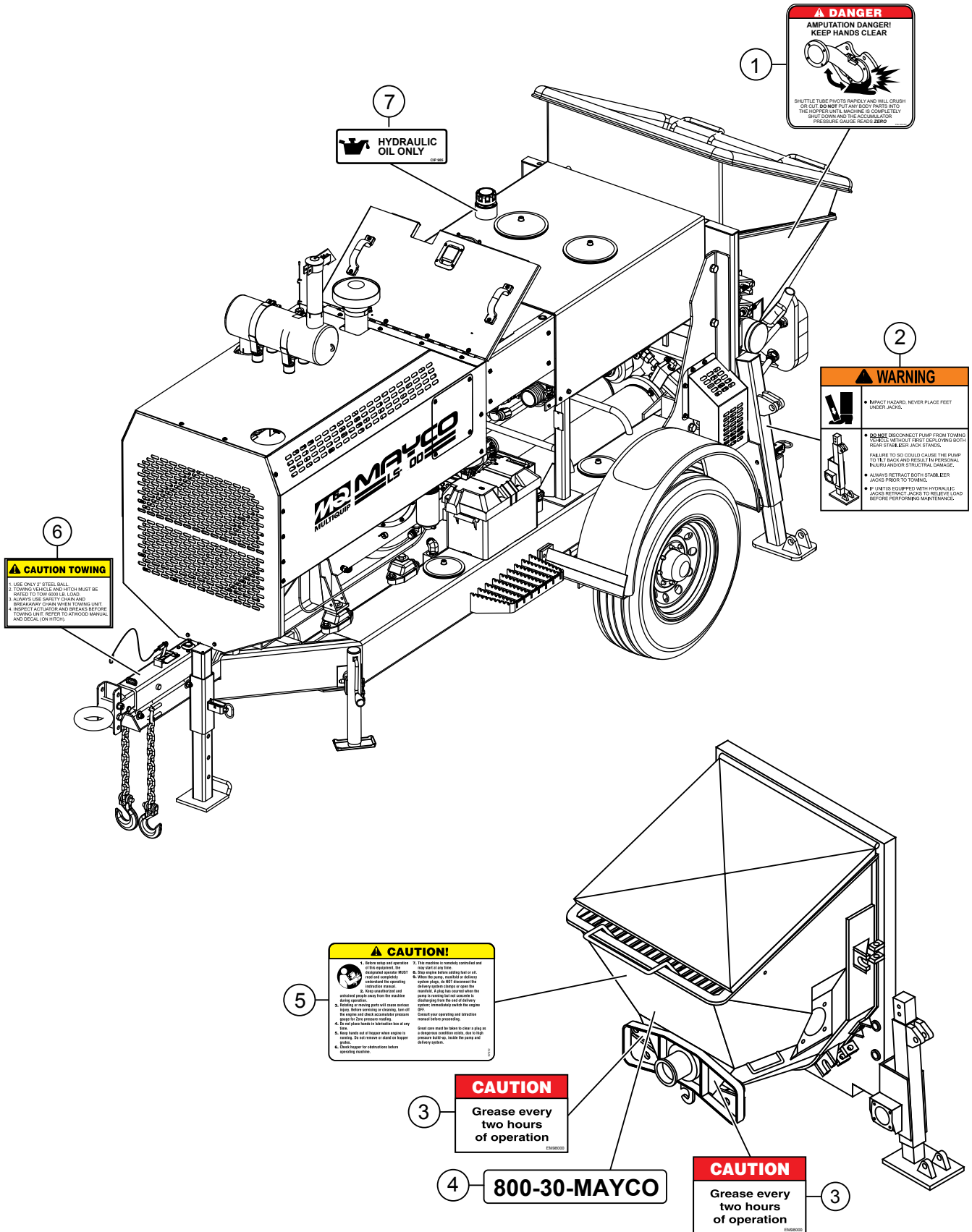

▲ DANGER
AMPUTATION DANGER!
KEEP HANDS CLEAR

SHUTTLE TUBE PIVOTS RAPIDLY AND WILL CRUSH OR CUT DOWN PUT ANY BODY PARTS INTO THE HIPPER UNTIL MACHINE IS COMPLETELY SHUT DOWN AND THE ACCUMULATOR PRESSURE GAUGE READS ZERO

▲ WARNING

- IMPACT HAZARD. NEVER PLACE FEET UNDER JACKS.
- **DO NOT** DISCONNECT PUMP FROM TOWING POINTS WITHOUT FIRST ERECTING BOTH REAR STABILIZER JACK STANDS.
- PUMP MUST BE SECURED ONCE THE PUMP TO BE TOWED BACK AND RESULT IN PERSONAL INJURY AND/OR STRUCTURAL DAMAGE.
- ALWAYS RETRACT BOTH STABILIZER JACKS PRIOR TO TOWING.
- IF UNIT IS EQUIPPED WITH HYDRAULIC JACKS RETRACT JACKS TO RELIEVE LOAD BEFORE PERFORMING MAINTENANCE.

▲ CAUTION TOWING

1. USE ONLY 2" STEEL BALL
2. CHAIN, VEHICLE AND HITCH MUST BE RATED TO TOW 6000 LB. LONG
3. ALWAYS USE SAFETY CHAIN AND BREAKAWAY CHAIN WHEN TOWING LINE
4. INSPECT ACTUATOR AND BREAKS BEFORE TOWING LINE. REFER TO WOODS MANUAL AND DECAL (ON HITCH)

HYDRAULIC OIL ONLY

▲ CAUTION!

1. Before using and operation of this equipment, the operator must read and understand the operating instructions and safety precautions.
2. Keep one hand on the control lever at all times.
3. Before or during use, never touch the engine and check accumulator pressure gauge to zero pressure reading.
4. Do not place hands in lubrication line of any shaft.
5. Check for oil leakage when engine is running. Do not remove or adjust air filter or other parts.
6. Check for oil leaks before starting engine.
7. This machine is remotely controlled and will start if the fuel is supplied.
8. Do not operate before adding fuel oil.
9. When the engine is started or idling, never touch the engine or any other parts of the machine.
10. Do not touch the engine or any other parts of the machine when the engine is running.
11. Do not touch the engine or any other parts of the machine when the engine is running.
12. Do not touch the engine or any other parts of the machine when the engine is running.
13. Do not touch the engine or any other parts of the machine when the engine is running.
14. Do not touch the engine or any other parts of the machine when the engine is running.
15. Do not touch the engine or any other parts of the machine when the engine is running.
16. Do not touch the engine or any other parts of the machine when the engine is running.
17. Do not touch the engine or any other parts of the machine when the engine is running.
18. Do not touch the engine or any other parts of the machine when the engine is running.
19. Do not touch the engine or any other parts of the machine when the engine is running.
20. Do not touch the engine or any other parts of the machine when the engine is running.

CAUTION
 Grease every two hours of operation

CAUTION
 Grease every two hours of operation

NAMEPLATE AND DECALS ASSY.

<u>NO.</u>	<u>PART NO.</u>	<u>PART NAME</u>	<u>QTY.</u>	<u>REMARKS</u>
1	DCL301	DECAL, DANGER SHUTTLE TUBE	1	
2	518090	DECAL, WARNING IMPACT HAZARD	1	
3	EM510386	DECAL, CAUTION-GREASE 2 HOURS	2	
4	EM511709	DECAL, 800-30-MAYCO	1	
5	EM97072	DECAL, CAUTION OPERATIONS INSTRUCT.	1	
6	EM969	DECAL, CAUTION TOWING	1	
7	EM985	DECAL, HYDRAULIC OIL	1	

FRAME ASSY.

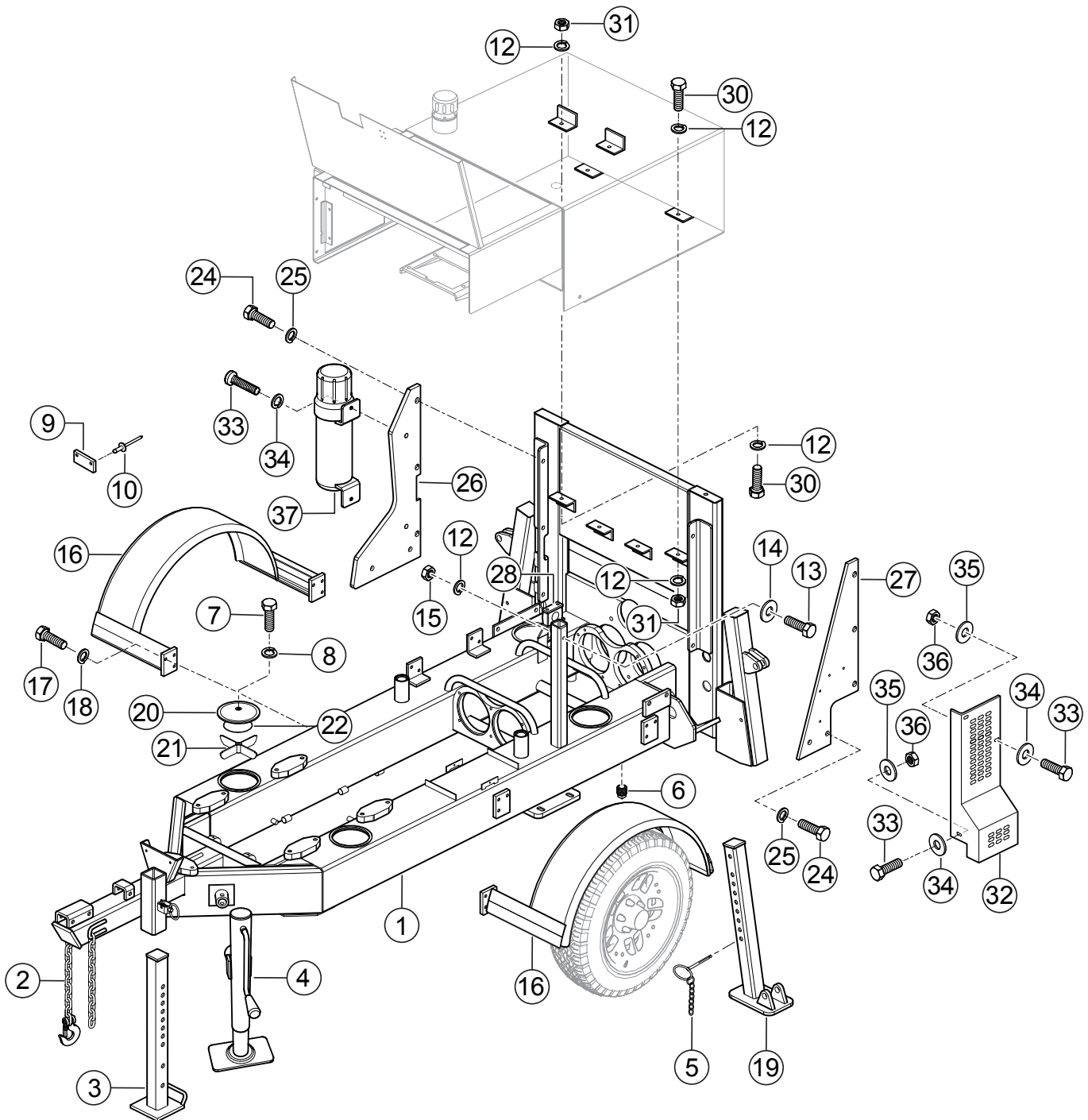

FRAME ASSY.

<u>NO.</u>	<u>PART NO.</u>	<u>PART NAME</u>	<u>QTY.</u>	<u>REMARKS</u>
1	518906	FRAME, MAIN	1	
2	EE43513	CHAIN, TRANSPORT W/HOOK, 3/8" X 42"	2	
3	EM70186	JACK STAND, FRONT	1	
4	EM25610	JACK STAND, SWIVEL, TRAILER	1	
5	EM744	CLEVIS PIN	2	
6	491214	PLUG, PIPE	1	
7	505990	BOLT, 1/2" X 2-1/2"	6	
8	520343	O-RING	6	
9	EM942	TAG, ALUMINUM	1	
10	EM491744	RIVET, POP AM-44	2	
12	0166 A	WASHER, LOCK 3/8"	5	
13	503112	BOLT, 3/8" X 2-3/4"	1	
14	3019092	WASHER, 3/8"	2	
15	EM969013	NUT, 3/8"	1	
16	517985	FENDER, BOLT-ON	2	
17	EM504456	BOLT, 1/2-13 X 3/4" HEX. GRD8	12	
18	6109180	WASHER, LOCK 1/2"	12	
19	EM517113	STABILIZER STAND	2	
20	EM800302	COVER	4	
21	EM800304	RETAINER	4	
22	EM800303	O-RING	4	
24	517124	BOLT, 3/4" NC X 1" GRD5	10	
25	492628	WASHER, LOCK 3/4"	10	
26	517092	SUPPORT PLATE, RIGHT	1	
27	517095	SUPPORT PLATE, LEFT	1	
28	EM98048	CLAMP	1	
30	EM963610	CAP SCREW, 3/8" NC X 1-1/4" GRD8	2	
31	492542	NUT, 3/8" NC HEX GRD2	2	
32	EM517742	GUARD, SHUTTLE CYLINDER	1	
33	0202	SCREW, HHC 5/16-18 X 1" ZN	4	
34	EM923023	WASHER, FLAT 5/16"	8	
35	EM923343	WASHER, LOCK 5/16"	4	
36	492541	NUT, 5/16" NC	4	
37	23297	MANUAL HOLDER	1	

AXLE/BRAKE LINE AND LIGHT ASSY.

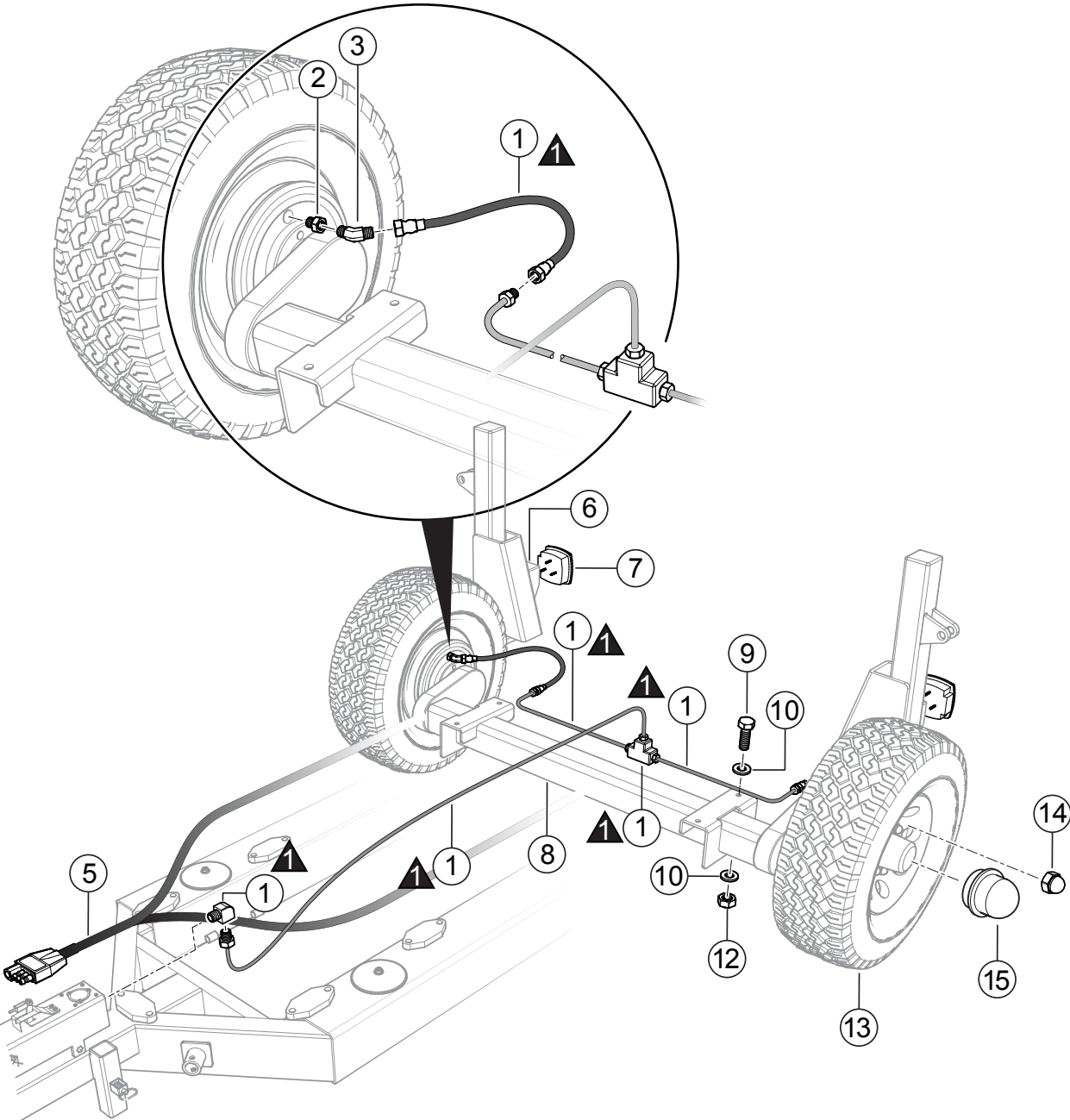

NOTE: ▲ MAIN BRAKE LINE KIT

AXLE/BRAKE LINE AND LIGHT ASSY.

<u>NO.</u>	<u>PART NO.</u>	<u>PART NAME</u>	<u>QTY.</u>	<u>REMARKS</u>
1	34566	KIT, MAIN BRAKE LINES	1	
2	EM512877	ADAPTOR, STRAIGHT	2	
3	EM512876	ADAPTOR, ELBOW	3	
5	EM515419	HARNESS, BRAKE LIGHTS	1	
6	517963	GUARD, TAIL LIGHT	2	
7	29242	LIGHT, TAIL, BRAKE	2	
8	EM800863	AXLE ASSY., TORSION 7000 LBS	1	
9	EM104	BOLT, 5/8-11 X 2" HEX HD	4	
10	0401450160	WASHER, 5/8" FLAT	8	
12	EM968013	NUT, HEX 5/8-11	4	
13	800684	WHEEL, TIRE/RIM 16" 8 LUG	2	
14	EM26519	NUT, LUG, CHROME	16	
15	801684	CAP, GREASE, CHROME	2	

TRAILER HITCH ASSY.

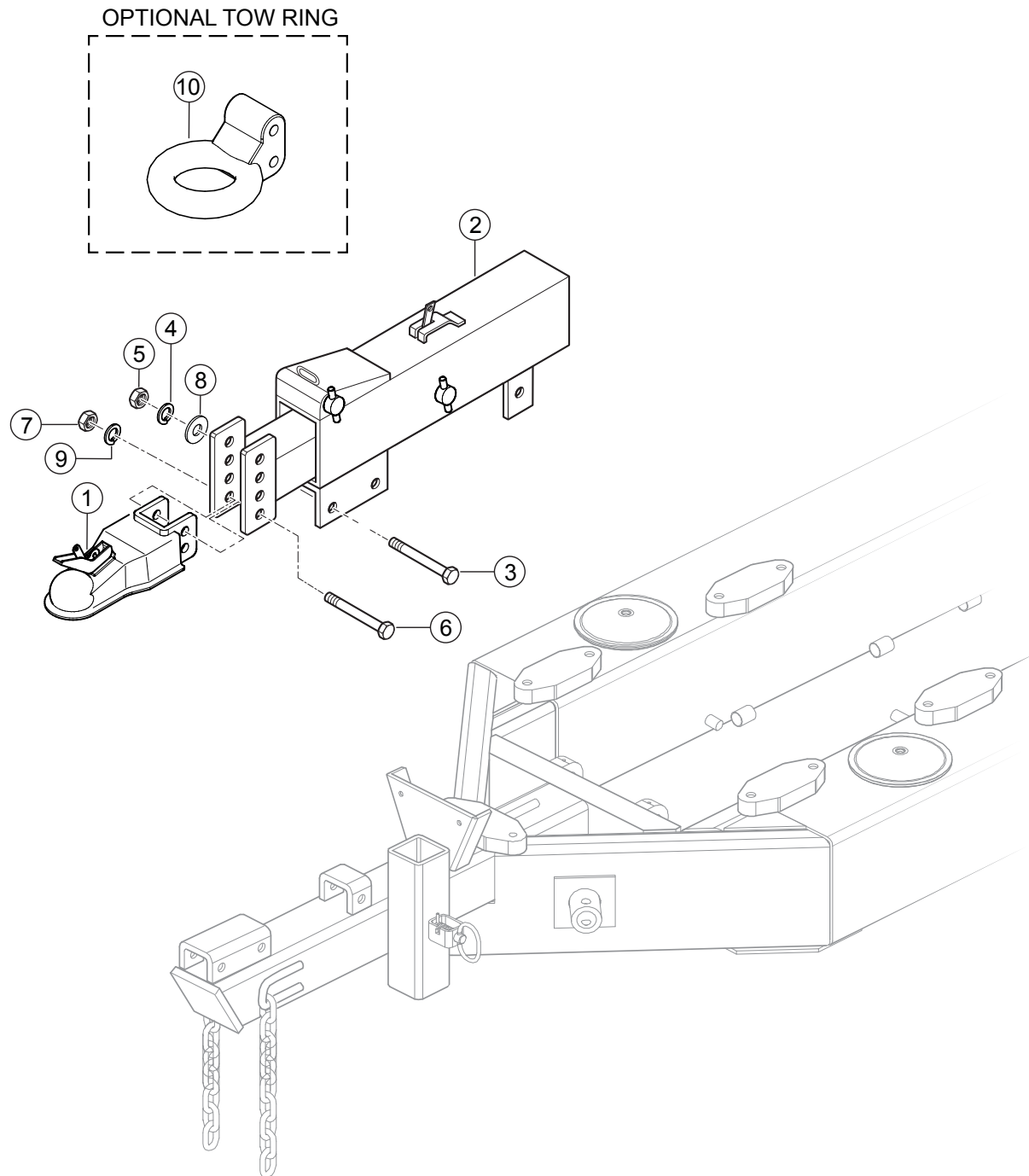

TRAILER HITCH ASSY.

<u>NO.</u>	<u>PART NO.</u>	<u>PART NAME</u>	<u>QTY.</u>	<u>REMARKS</u>
1	29228	COUPLING, 2" BALL, 8000 LBS	1	
1	EE56638	COUPLING, 2-5/16" BALL ADJ., 14,500 LBS.....	1.....	OPTION
2	19067	ACTUATOR, BRAKE	1	
3	503111	BOLT, HEX HD 1/2" NC X 4-1/2" GRD5	3	
4	6109180	WASHER, LOCK 1/2"	3.....	REPLACES P/N 492626
5	EM492584	NUT, LOCK 1/2"	3	
6	EM507658	BOLT, HEX HD 5/8" NC X 4-1/2" GRD5	2	
7	EM492586	NUT, LOCK 5/8"	2	
8	6109170	WASHER, FLAT 1/2"	2	
9	EM923348	WASHER, LOCK 5/8"	2	
10	29369	COUPLER, 3" PINTLE EYE, 14,000 LBS.....	1.....	OPTION

BATTERY BOX ASSY.

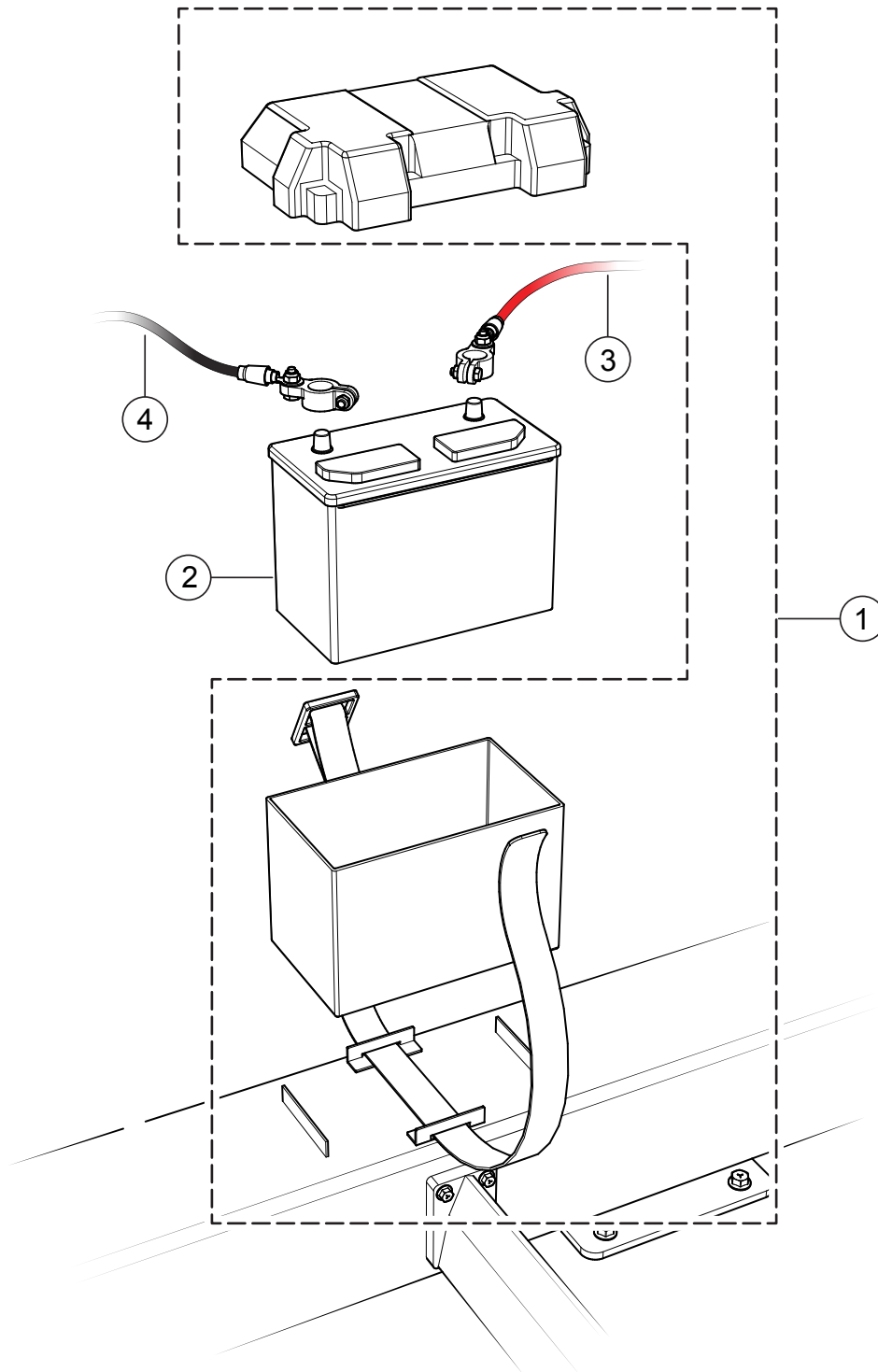

BATTERY BOX ASSY.

<u>NO.</u>	<u>PART NO.</u>	<u>PART NAME</u>	<u>QTY.</u>	<u>REMARKS</u>
1	34506	BATTERY BOX W/BELT	1	
2		BATTERY 12V	1.....	OBTAIN LOCALLY
3	800126	BATTERY CABLE, POSITIVE	1	
4	800127	BATTERY CABLE, NEGATIVE	1	

HOPPER ASSY.

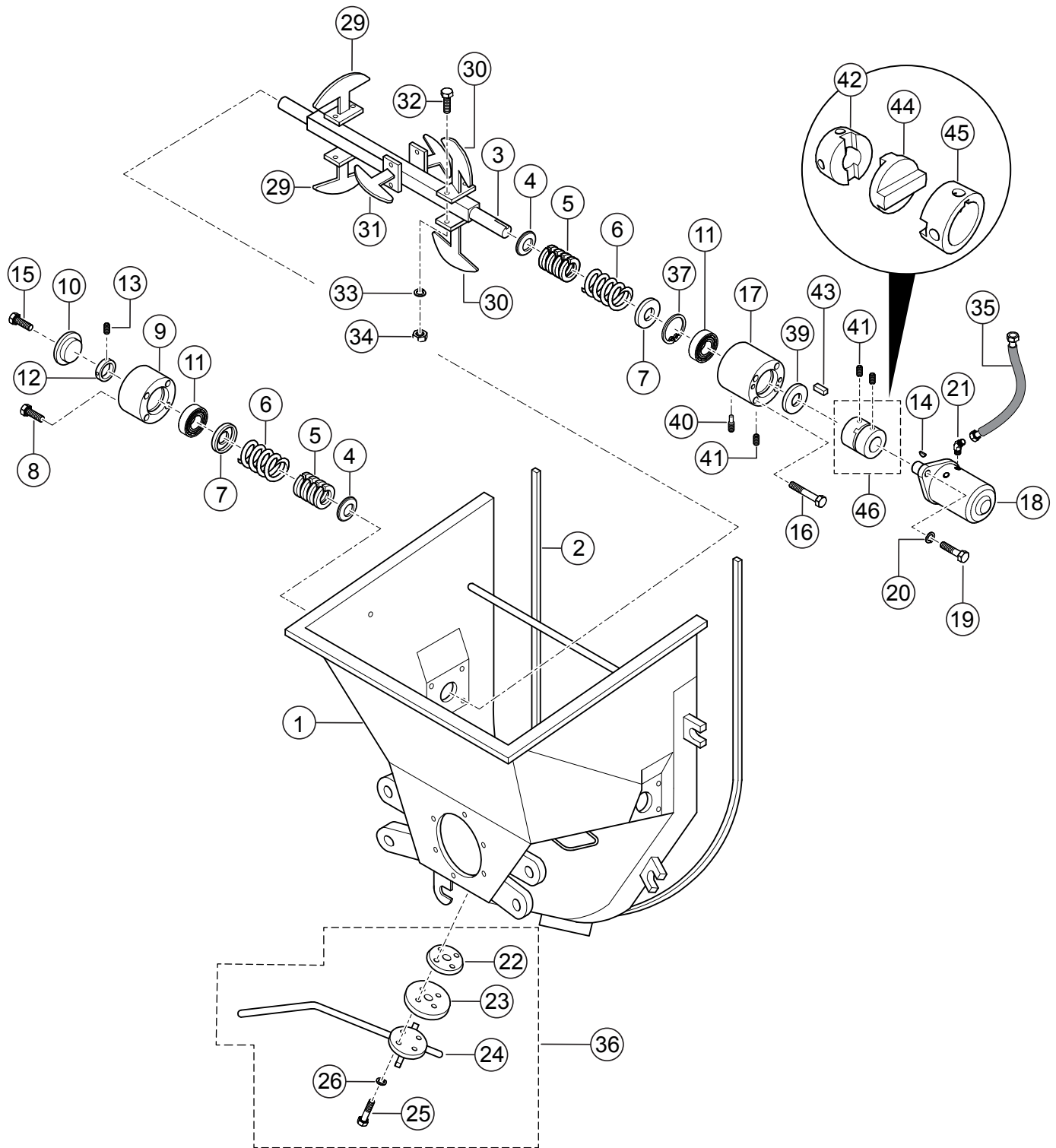

HOPPER ASSY.

<u>NO.</u>	<u>PART NO.</u>	<u>PART NAME</u>	<u>QTY.</u>	<u>REMARKS</u>
1	EM515980	HOPPER ASSY.	1	
2	EM16184	HOPPER SEAL	1	
3	802873	REMIXER SHAFT	1	
4	EM200303	FOLLOWER RING	2	
5	EM200301	RING, PACKING	8	
6	EM516820	COMPRESSION SPRING	2	
7	EM514339	HOPPER SPRING SEAT	2	
8	EM510717	BOLT, 1/2" X 1-3/4"	4	
9	EM514338	SUPPORT, LEFT	1	
10	EM514706	END CAP, SHAFT SUPT.	1	
11	EM902153	BEARING	2	
12	EM200018	SET COLLAR	1	
13	EM703	SET SCREW	2	
14	EM500264	KEY, 3/8" X 30MM	1	
15	520467	BOLT, 5/16"NF X 1" GRD 8.8	4	
16	511427	SCREW, 1/2-13 X 3" ALLEN HD	4	
17	EM516780	HOUSING	1	
18	EM98108	MOTOR, REMIX	1	
19	505989	SCREW, SOCKET 1/2-13 X 1-1/4" GRD5	2	
20	6109180	WASHER, LOCK 1/2"	2	
21	EM25508	ADAPTER, FITTING	2	
22\$	EM708601	PISTON CUP HOLDER	1	
23\$	EM50417	PISTON CUP	1	
24\$	EM508830	HANDLE	1	
25\$	492378	BOLT, 3/8" X 1-3/4"	4	
26\$	0166 A	WASHER, LOCK 3/8"	4	
29	EM514031	PADDLE ARM, END	2	
30	EM514032	PADDLE ARM, MOTOR END	2	
31	EM514033	PADDLE ARM, CENTER	2	
32	EM963110	BOLT, HX HD 1/2-13 X 3-1/4"	6	
33	6109180	WASHER, LOCK 1/2"	6	
34	492589	NUT, HEX 1/2"	6	
36	EM70860	HOPPER CLEANOUT PLUG ASSY.....	1	INCLUDES ITEMS W/\$
37	EM490985	RETAINING RING	1	
39	EM516799	SPACER, 6MM	1	
40	EM702	SET SCREW, DOG POINT 3/8"	1	
41%	EM703	SET SCREW, 3/8"	3	
42%		REMIX SHAFT COUPLER	1	NOT SOLD SEPARATELY
43	EM500264	SQUARE KEY, 3/8" X 30MM	1	
44%		DRIVE MEMBER COUPLER.....	1	NOT SOLD SEPARATELY
45%		MOTOR SHAFT COUPLER.....	1	NOT SOLD SEPARATELY
46	802590	COUPLER ASSY.....	1	INCLUDES ITEMS W/%

HOPPER ATTACHMENT ASSY.

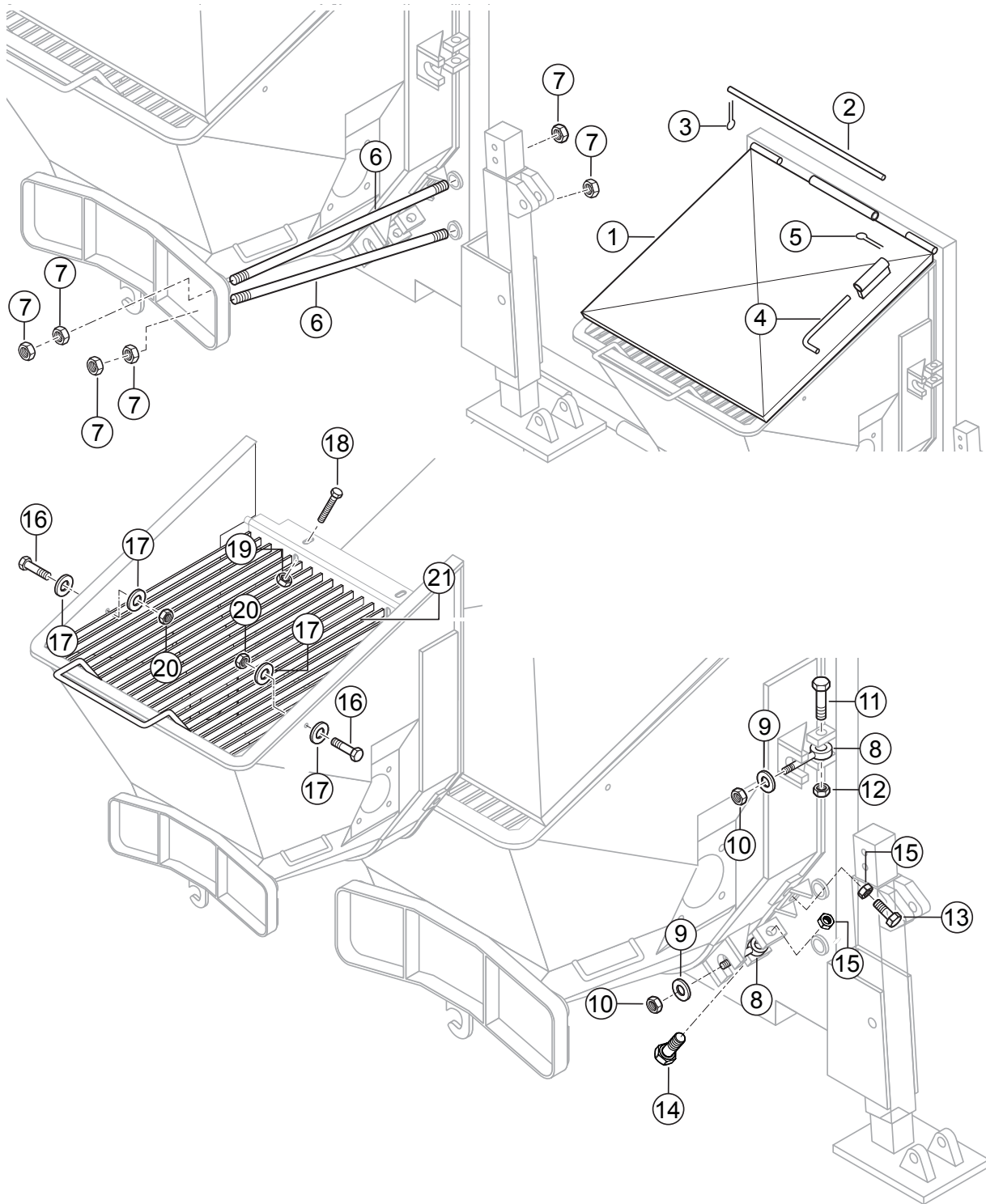

HOPPER ATTACHMENT ASSY.

<u>NO.</u>	<u>PART NO.</u>	<u>PART NAME</u>	<u>QTY.</u>	<u>REMARKS</u>
1	EM514204	SPLASH PLATE	1	
2	EM514620	HINGE PIN	1	
3	EM491686	COTTER PIN, 1/8" X 1-1/2"	1	
4	EM70134-2	PIN, SPLASH PLATE	1	
5	EM505723	COTTER PIN, 5/32" X 1-1/2"	1	
6	EM16166	TIE ROD	4	
7	EM424	NUT, HEX HD 1" NC	12	REPLACES P/N 505728
8	EM14165	EYE BOLT, 3/4"	4	
9	EM619	O-RING, 3/4"	4	
10	EM968446	NUT, HEX 3/4"	4	
11	505121	BOLT, 3/4" X 3"	4	
12	EM968446	NUT, HEX 3/4"	4	
13	505123	BOLT, HEX HD 1/2" X 2-1/2"	2	
14	492491	BOLT, HEX HD 1/2" X 1-1/2"	1	
15	6109160	NUT, HEX 1/2"	3	
16	492379	SCREW, CAP 3/8"	2	
17	3019092	WASHER, FLAT 3/8"	4	
18	515395	BOLT, 7/16" NC X 4" GRD5	2	
19	492584	NUT, LOCK 1/2"	2	
20	EM969013	NUT, NYLOC	2	
21	EM514357	HOPPER SCREEN	1	

HOPPER INTERIOR ASSY.

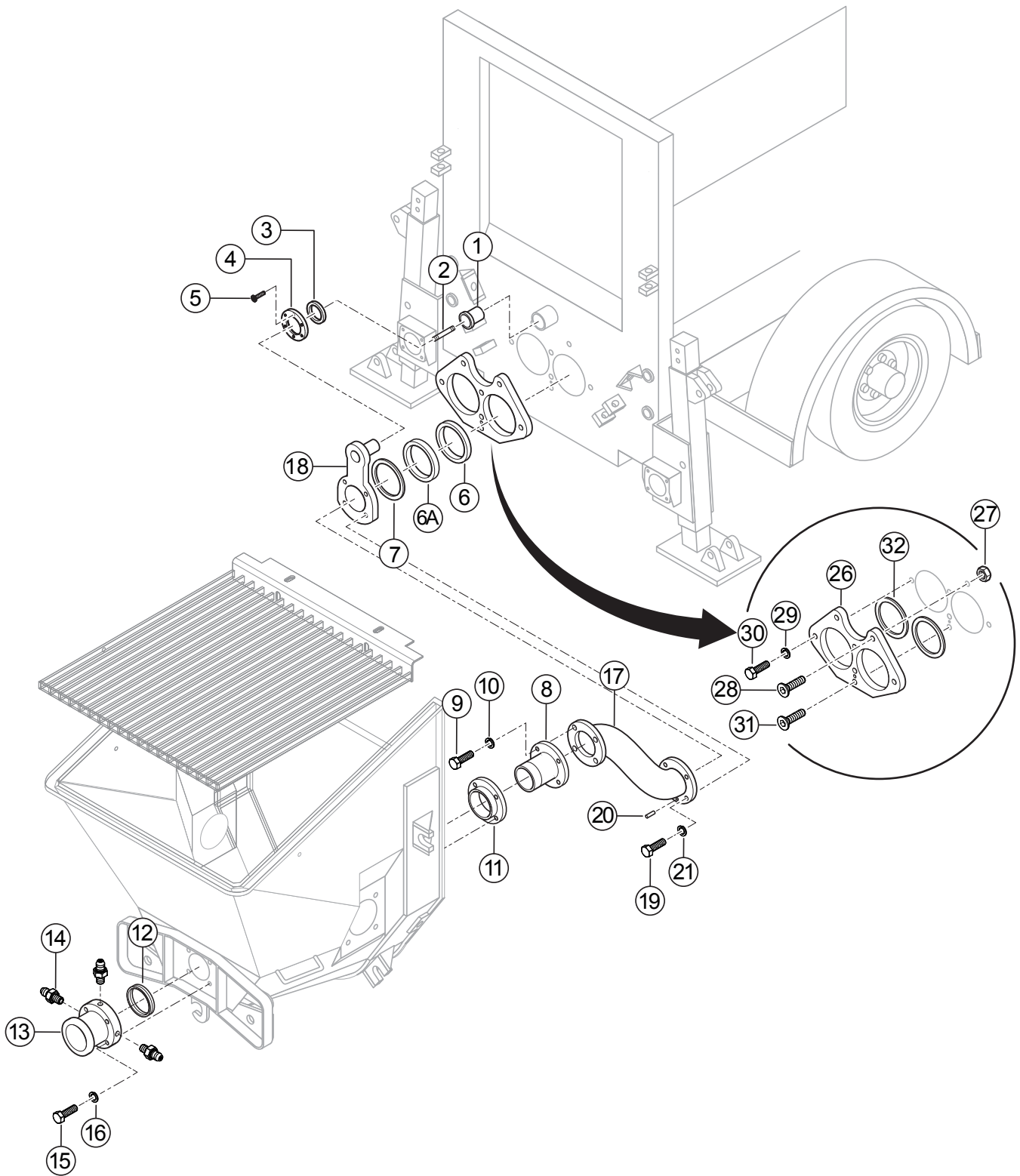

HOPPER INTERIOR ASSY.

<u>NO.</u>	<u>PART NO.</u>	<u>PART NAME</u>	<u>QTY.</u>	<u>REMARKS</u>
1	EM800609	BUSHING, HOPPER SIDE	1	
2	EM284	STUD, 1-14 X 5" GRD 8	1	
3	800426	RUBBER SEAL	1	
4	800427	RETAINER PLATE	1	
5	506176	BOLT, 5/16-18 X 1" FHAS	6	
6	EM98022	WEAR RING HF	1	
6A	EM168161A	RING, ENERGIZER RUBBER	1	
7	EM168162	RING, INSERT STEEL	1	
8	EM16804	SLEEVE 5"	1	
9	EM104	BOLT, 5/8" X 2"	4	
10	EM923348	WASHER, LOCK 5/8"	4	
11	EM25803	BEARING, DISCHARGE PLATE	1	
12	EM98065	SEAL, GROOVED RUBBER	1	
13	EM512212	DISCHARGE NIPPLE	1	
14	491701	GREASE FITTING	3	
15	EM210	BOLT, 5/8" X 2"	6	
16	6109180	WASHER, 1/2"	6	
17	EM16811	SHUTTLE CYLINDER	1	
18	EM25843	NUN PLATE	1	
19	EM104	BOLT, HEX HD 5/8" X 2"	4	
20	419719	PIN	1	
21	EM923348	WASHER, LOCK 5/8"	4	
26	EM98021A	WEAR PLATE, ONE SIDED	1	
27	EM968013	NUT, HEX 5/8-11 BRT. FIN.	2	
28	EM265	BOLT, 5/8-11 X 3" COUNTER SUNK	2	
29	492628	WASHER, LOCK 3/4"	2	
30	EM151	BOLT, HEX HD 3/4-10 X 2"	2	
31	EM264	BOLT, 1/2-13 X 3"	1	
32	EM517700	O-RING	2	

SHUTTLE CYLINDER ASSY.

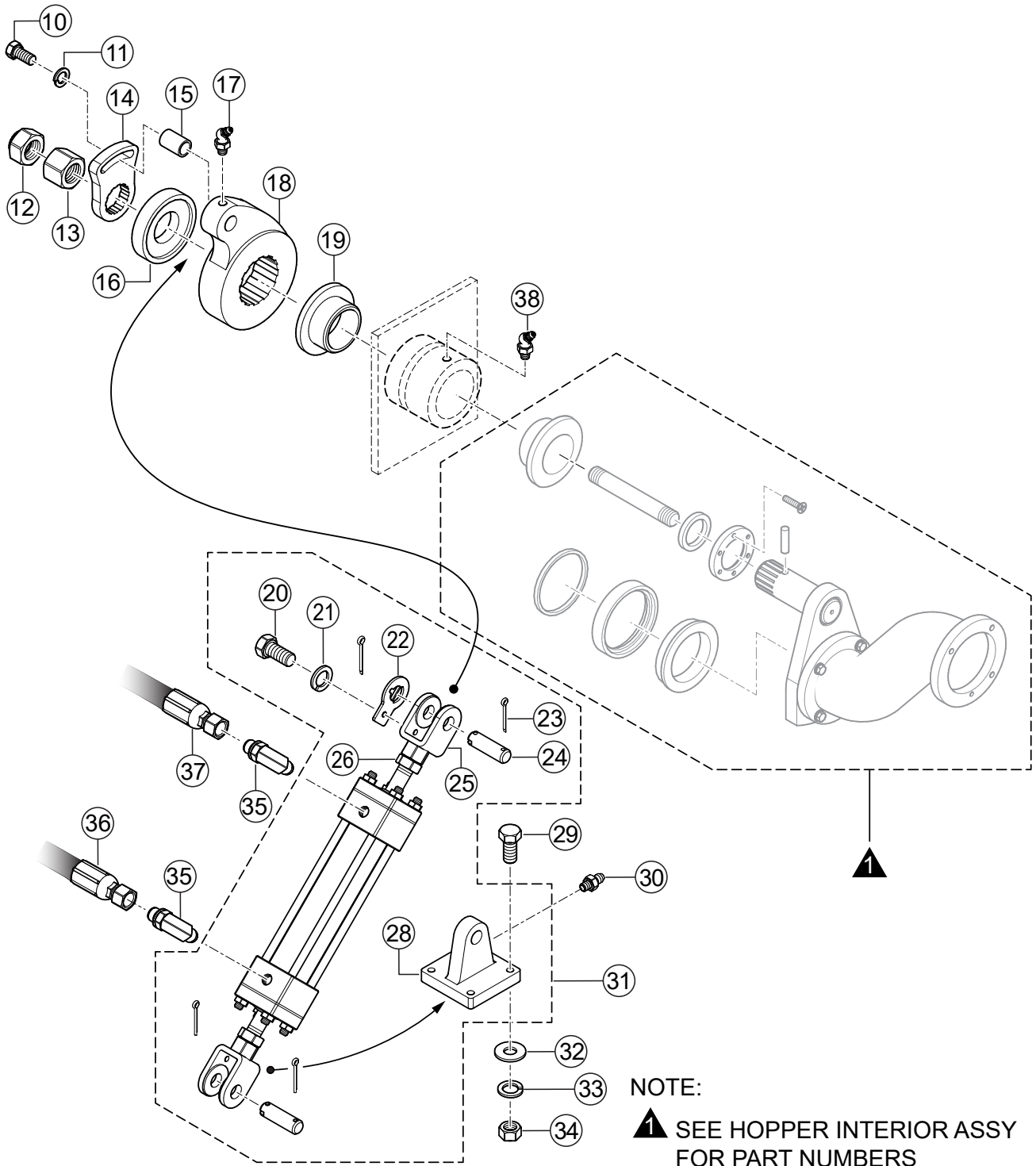

SHUTTLE CYLINDER ASSY.

<u>NO.</u>	<u>PART NO.</u>	<u>PART NAME</u>	<u>QTY.</u>	<u>REMARKS</u>
10	EM963692	BOLT, 1/2" UNC X 1-1/2"	1	
12	EM417	NUT, FLEX LOCK 1-14NF GRD 5	1	
13	EM509221	NUT, 1-14UNF, GRD 5	1	
14	EM518555	CRANK ARM NUT LOCK	1	
15	EM518556	BUSHING, CRANK ARM	1	
16	EM16814	SHUTTLE TENSIONER	1	
17	EM50449	FITTING ELBOW	1	
18	510514	SHUTTLE CRANK, SPLINED SHAFT	1	
19	EM16145A	BUSHING, SWING AXLE	1	
20\$	492363	BOLT, 5/16" NC X 3/4" GRD 5	1	
21\$	EM923343	WASHER, LOCK 5/16"	1	
22\$	802009	LOCK	1	
23\$	EM924008	COTTER PIN, 1/8" X 1-1/2"	4	
24\$	521139	WRIST PIN	2	
25\$	521141	FEMALE CLEVIS	1	
26\$	515249	NUT, JAM 1-14	2	
28\$	EM254549	PIVOT BRACKET	1	
29	492397	SCREW, 1/2"NC X 2-1/2" GRD 5	4	
30	EM505490	GREASE FITTING	2	
31	EM98106CU	CYLINDER SHUTTLE ASSY.	1	
32	EM621	WASHER, 1/2"	4	
33	6109180	WASHER, LOCK 1/2"	4	
34	492584	NUT, LOCK 1/2"NC	4	
35	3322	FITTING, 90° 10MJ-10MO	2	
36	802797	HOSE, HYDRAULIC	1	
37	802798	HOSE, HYDRAULIC	1	
38	EM510684	GREASE FITTING	1	

LUBRICATION PISTONS ASSY.

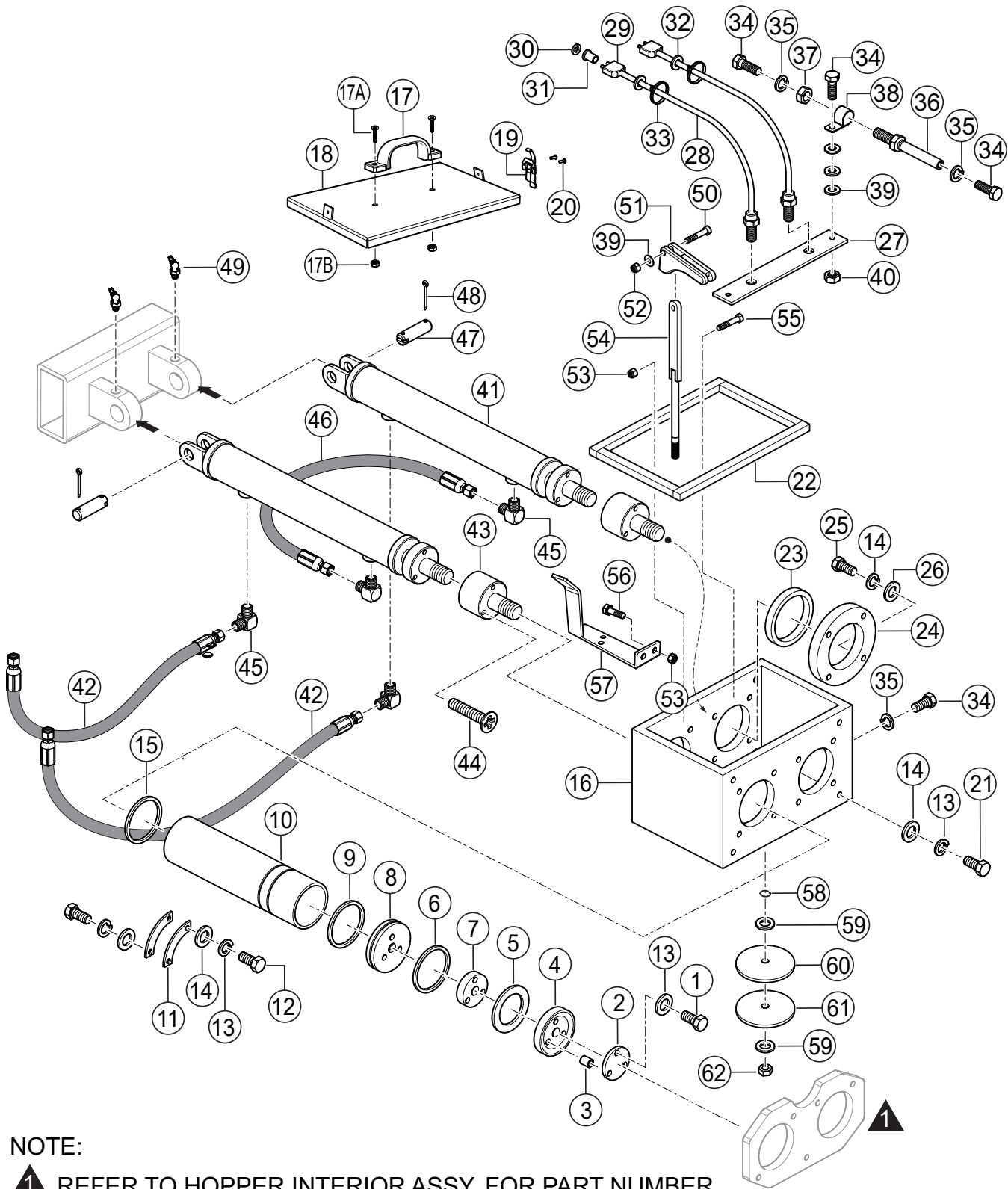

NOTE:

▲ 1 REFER TO HOPPER INTERIOR ASSY. FOR PART NUMBER

LUBRICATION PISTONS ASSY.

<u>NO.</u>	<u>PART NO.</u>	<u>PART NAME</u>	<u>QTY.</u>	<u>REMARKS</u>
1	510265	BOLT, HX HD 3/8"NC X 3-1/2" GRD 8	6	
2	EM16464	FACE PLATE	2	
3	EM16465	PISTON CUP SPACER	6	
4	EM98050	CUP, PISTON-ORANGE	2	
5	EM14408	RING, BRONZE	2	
6	EM16493	RING, FELT	2	
7	EM16462	FELT HOLDER	2	
8	EM98033	OILER PLATE W/HOLES	2	
9	EM14407	O-RING, OILER PLATE	2	
10	EM25801	CYLINDER, CONCRETE	2	
11	EM25110	RETAINER, CYLINDER	4	
12	EM963610	CAP SCREW, 3/8"NC X 1-1/4" GRD 8	8	
13	0166 A	WASHER, LOCK 3/8"	20	
14	3019092	WASHER, FLAT 3/8"	22	
15	EM16174	O-RING, A440	2	
16	802761	LUBRICATION BOX	1	
17	802751	HANDLE, PLASTIC	1	
17A	513312	BOLT, 1/4" X 1"	2	
17B	492581	NUT, 1/4-20 NYLON LOCK	2	
18	802997	COVER, LUBRICATION BOX	1	
19	EM514610	LATCH, COVER	1	
20	491754	RIVET, AM-66	4	
21	492378	BOLT, 3/8"NC X 1-3/4"	6	
22	800033	SEAL, SQUARE	1	
23	EM274351	SEAL, LUBE BOX	2	
24	EM50425	FLANGE, RING	2	
25	492451	BOLT, 3/8-24 X 1"	8	
26	EM50443	SEAL, OIL BOX	8	
27	EM514208	BAR, PROXIMITY SWITCH SUPPORT	2	
28	EM98163	SWITCH, PROXIMITY W/CABLE	2	
29	EM98135	HOUSING, FEMALE	2	
30	EM98134	SEAL, CONNECTOR HOUSING	6	
31	EM98138	TERMINAL PIN, FEMALE	6	
32	514611	GROMMET	2	
33	EM504505	TIE WRAP	8	
34	492303	SCREW, 5/16-18 X 1-1/4"	6	
35	EM923343	WASHER, LOCK 5/16"	6	
36	EM514216	ADJUSTMENT ROD, PROX. SWITCH	2	
37	6109160	NUT, HEX 1/2"	4	
38	EM514207	BRACKET, ADJUSTMENT ROD	2	
39	923023	WASHER, FLAT 5/16"	7	
40	2105164	NUT, 5/16"	2	

LUBRICATION PISTONS ASSY. (CONT'D.)

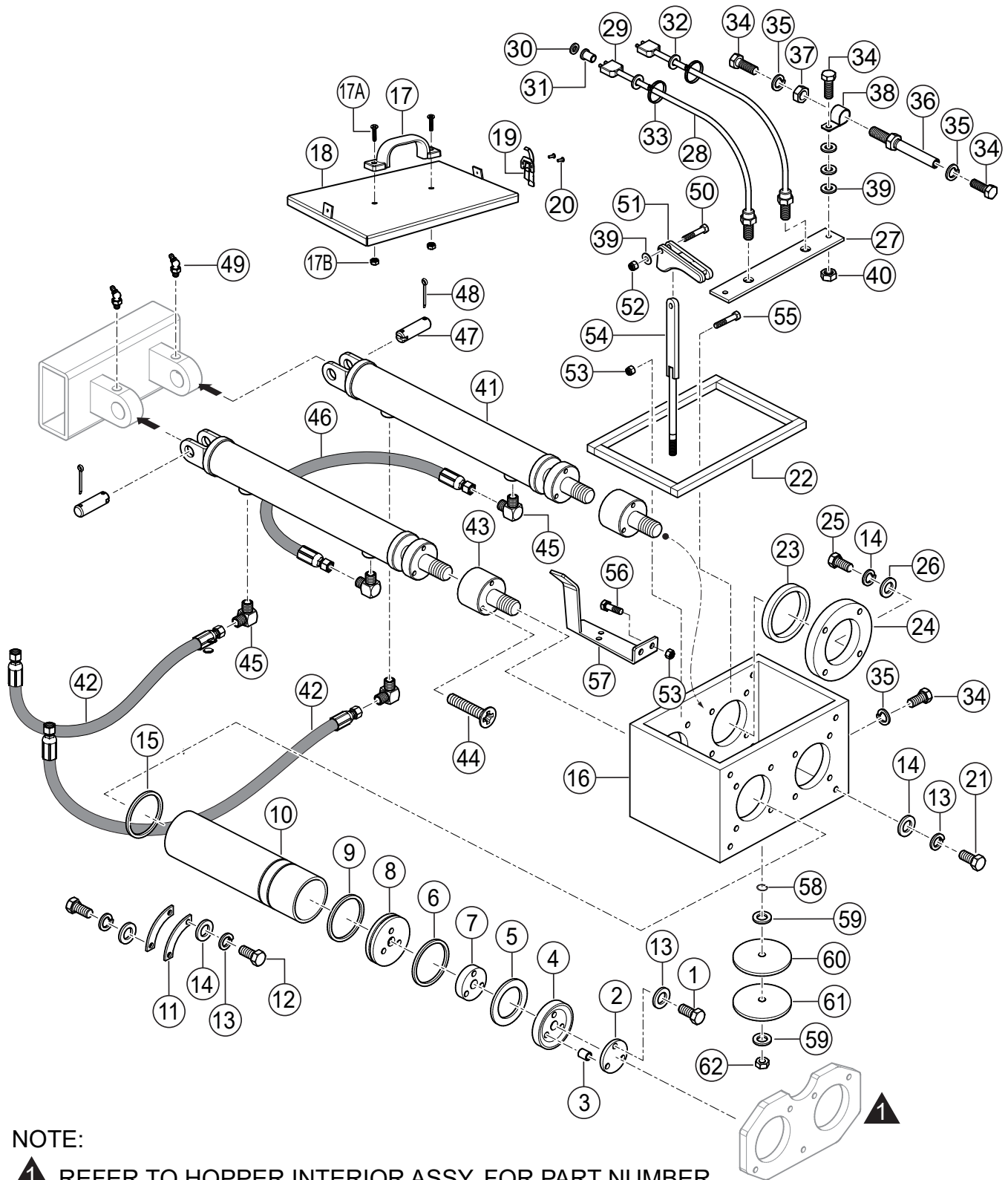

LUBRICATION PISTONS ASSY. (CONT'D.)

<u>NO.</u>	<u>PART NO.</u>	<u>PART NAME</u>	<u>QTY.</u>	<u>REMARKS</u>
41	EM98211	CYLINDER, HYDRAULIC, MAIN	2	
42	EM514920	HOSE, HYDRAULIC, MAIN CYL.	2	
43	EM514202	EXTENSION SPACER	2	
44	EM185	BOLT, SOCKET HEAD 3/8-16 X 3"	6	
45	EM25497	FITTING, 90°	4	
46	514067	HOSE, HYDRAULIC SLAVE	1	
47	EM16459	PIN, WRIST	2	
48	EM505723	PIN, COTTER	4	
49	EM491701	FITTING, GREASE	2	
50	492379	SCREW, CAP 3/8"	1	
51	802678	LEVER, RELEASE	1	
52	EM969013	NUT, NYLOK 3/8"NC	1	
53	2105164	NUT, NYLOK 5/16-18	1	
54	802677	PLUNGER, ROD	1	
55	2105162	BOLT, 5/16"NC X 1-3/4" GRD 5	2	
56	0202	SCREW, HHC 5/16-18 X 1" ZN	2	
57	802850	BRACKET, HOSE	1	
58	802955	RETAINING RING	1	
59	492599	WASHER, 1/2"	2	
60	802682	RUBBER SEAL	1	
61	802681	SEAL PLATE	1	
62	492584	NUT, LOCK 1/2"	1	

FUEL TANK ASSY.

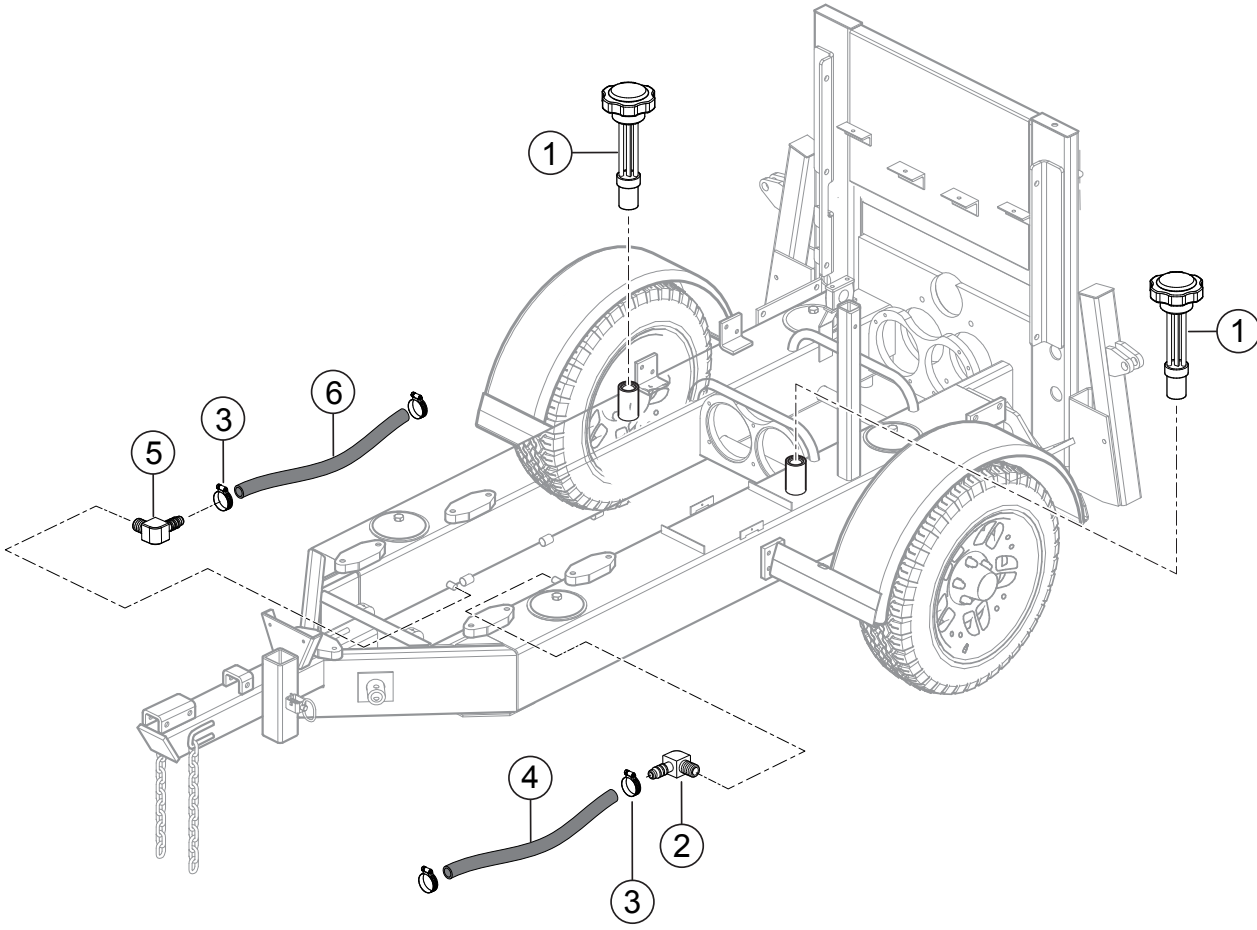

FUEL TANK ASSY.

<u>NO.</u>	<u>PART NO.</u>	<u>PART NAME</u>	<u>QTY.</u>	<u>REMARKS</u>
1	34507	FUEL CAP W/GAUGE	2	
2	EM514559	ELBOW, ADAPTER 90° MALE	1	
3	506208	CLAMP	4	
4	EM514536	HOSE, FUEL RETURN 5/16"	A/R.....	1 PC. =1 FT.
5	EM20426	ELBOW, BRASS 1/4" X 1/4" H	1	
6	EM20427	HOSE, 1/4" FUEL	A/R.....	1 PC. =1 FT.

HEAT EXCHANGER ASSY.

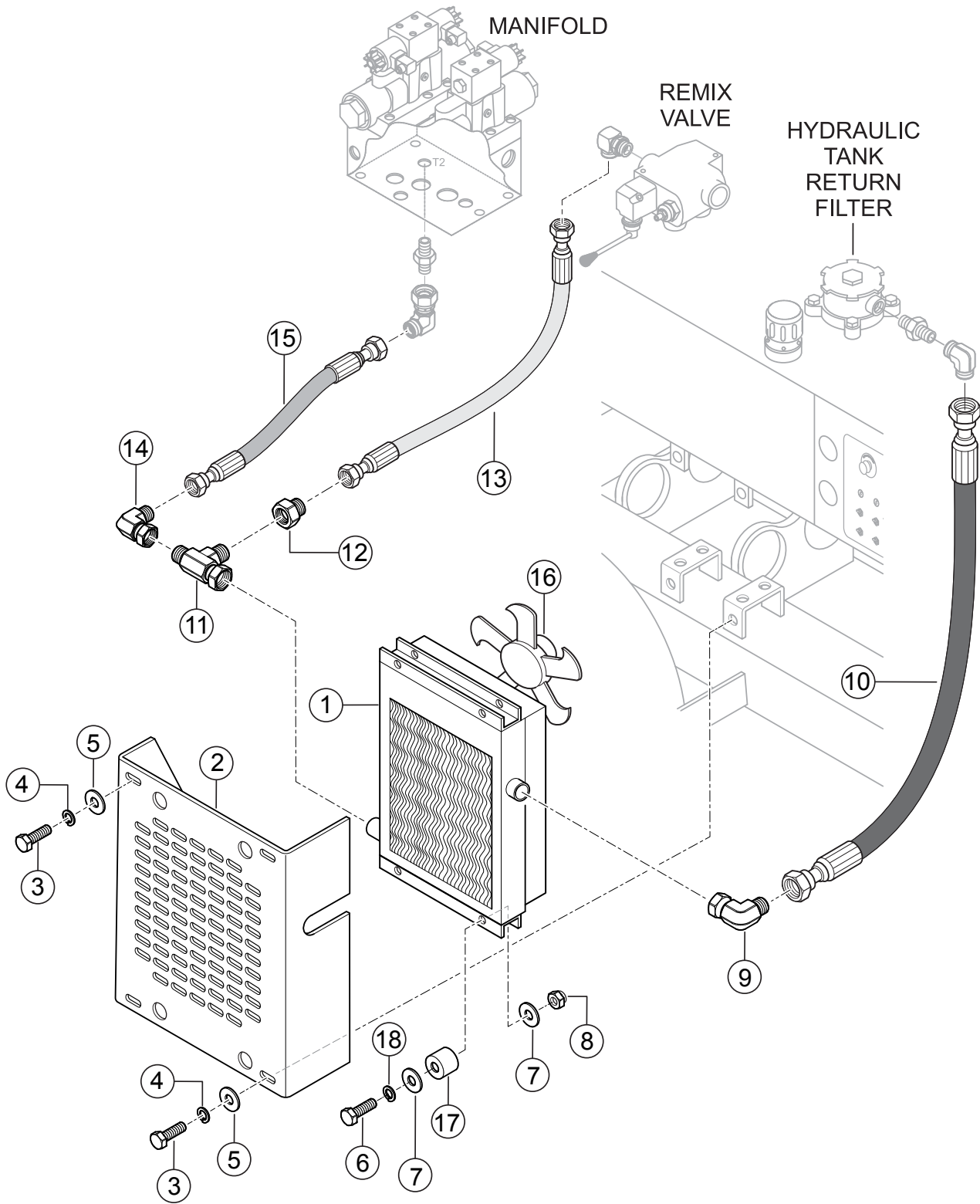

HEAT EXCHANGER ASSY.

<u>NO.</u>	<u>PART NO.</u>	<u>PART NAME</u>	<u>QTY.</u>	<u>REMARKS</u>
1	EM518993	HEAT EXCHANGER ASSY.	1	
2	EM519002	COVER, HEAT EXCHANGER	1	
3	EM963610	CAP SCREW, 3/8" NC X 1-1/4" GRD 8	4	
4	0166 A	WASHER, LOCK 3/8"	4	
5	3019092	WASHER, FLAT 3/8"	4	
6	EM492366	BOLT 5/16 X 1-1/2"	4	
7	EM923023	WASHER, FLAT 5/16"	8	
8	2105164	NUT 5/16"	4	
9	EM25497	FITTING	1	
10	EM514607	HOSE 4000 PSI	1	
11	EM25566	TEE 1", O-RING HYD. FITTING	1	
12	EM509345	FITTING	1	
13	EM514606	HOSE, 2000 PSI	1	
14	EM509401	ADAPTER	1	
15	519136	HOSE, 2000 PSI	1	
16	EM518993FM	MOTOR AND FAN ASSY.	1	
17	519271	CUSHION	2	
18	EM923343	WASHER, LOCK 5/16"	8	

ACCUMULATOR ASSY.

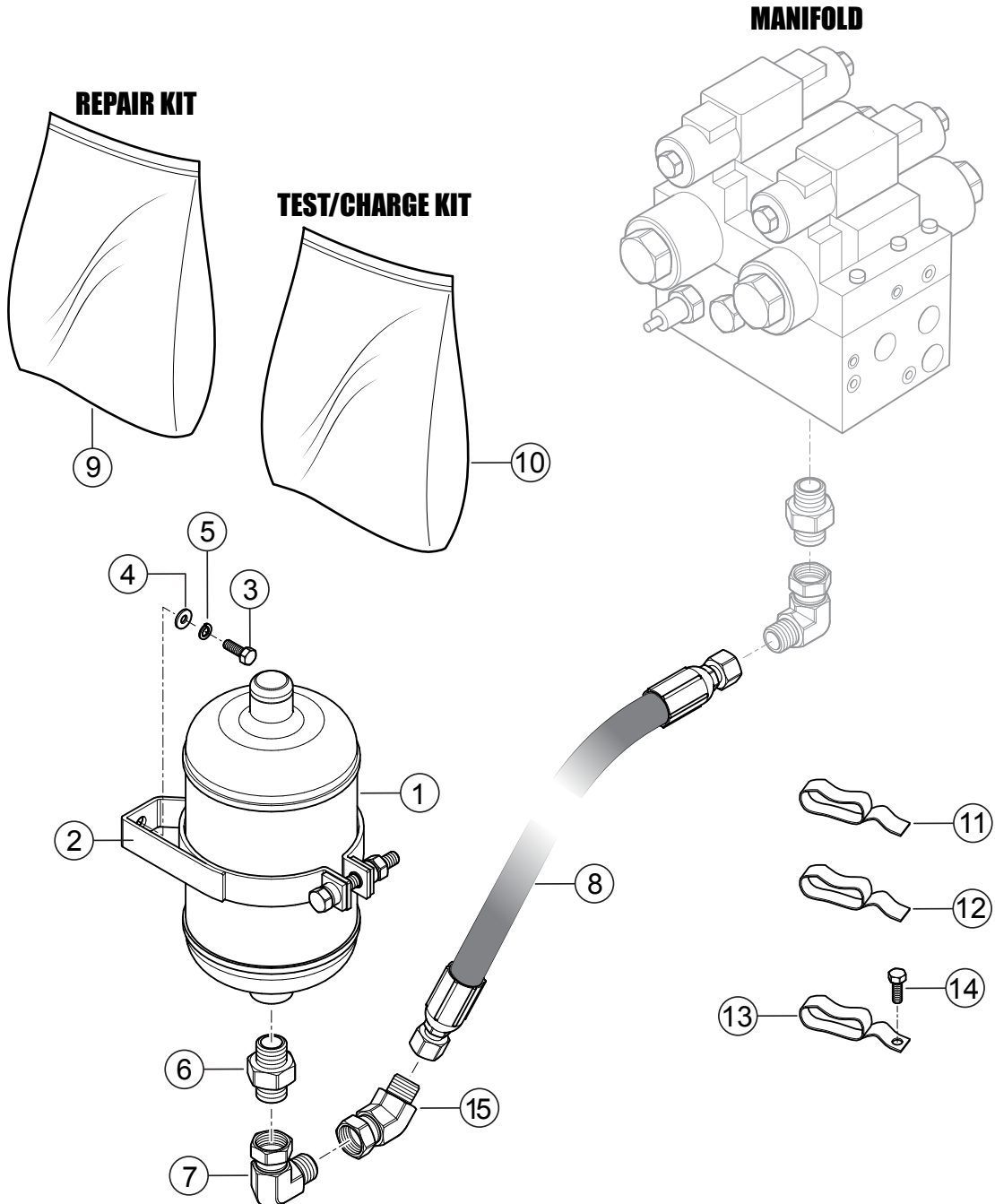

ACCUMULATOR ASSY.

<u>NO.</u>	<u>PART NO.</u>	<u>PART NAME</u>	<u>QTY.</u>	<u>REMARKS</u>
1	EM97015	ACCUMULATOR 1 GAL.	1	
2	EM97016	BRACKET, ACCUMULATOR	1	
3	EM963055	BOLT, HHCS 3/8" NC X 3/4" GRD 5	2	
4	3019092	WASHER, FLAT 3/8"	2	
5	0166 A	WASHER, LOCK 3/8"	2	
6	EM509425	FITTING, STRAIGHT	1	
7	EM509353	FITTING, 90° ELBOW	1	
8	EM514603	HOSE, ACCUMULATOR	1	
9	EM98009	KIT, ACCUMULATOR REPAIR	1	
10	EM98052	KIT, ACCUMULATOR TEST/CHARGE	1	
11	EM515105	STRAP CINCH 4" STD DUTY	2	
12	EM515106	STRAP CINCH 6" STD DUTY	6	
13	EM515107	STRAP HANGING, 8" HVY DUTY	2	
14	EM492299	BOLT, HEX HD 5/16" X 1/2"	2	
15	518198	ADAPTER, ELBOW 45 DEGREE	1	

REMIXER CONTROL ASSY.

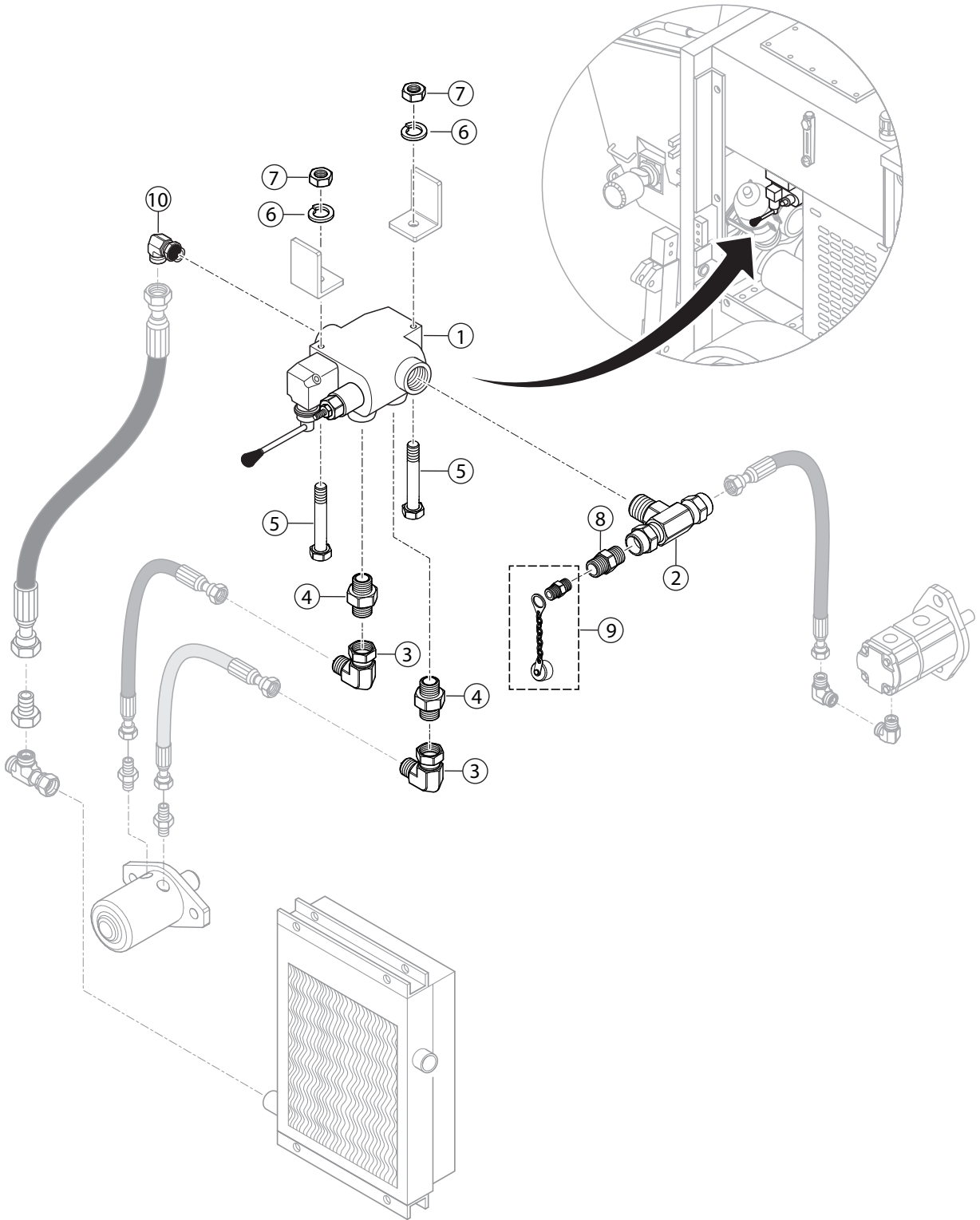

REMIXER CONTROL ASSY.

<u>NO.</u>	<u>PART NO.</u>	<u>PART NAME</u>	<u>QTY.</u>	<u>REMARKS</u>
1	EM97017	VALVE REMIXER W/LEVER	1	
2	515384	ADAPTER FITTING, TEE	1	
3	506195	FITTING, 90° ELBOW	1	
4	EM25509	ADAPTER FITTING, STRAIGHT	2	
5	EM218	BOLT 5/16" X 2-1/2"	2	
6	EM923343	WASHER, LOCK 5/16"	2	
7	2105164	NUT, HEX 5/16"	2	
8	EM98015	COUPLING 1/4" PIPE	1	
9	EM98014	TEST PORT	1	
10	EM25507	FITTING, 90° ELBOW	1	

LUBRICATION PANEL ASSY.

NOTE:

 Grease daily, two or three shots of #2 multipurpose automotive grease. Overgreasing any bearing will not damage the machine. **ALWAYS** grease *before and after* operation.

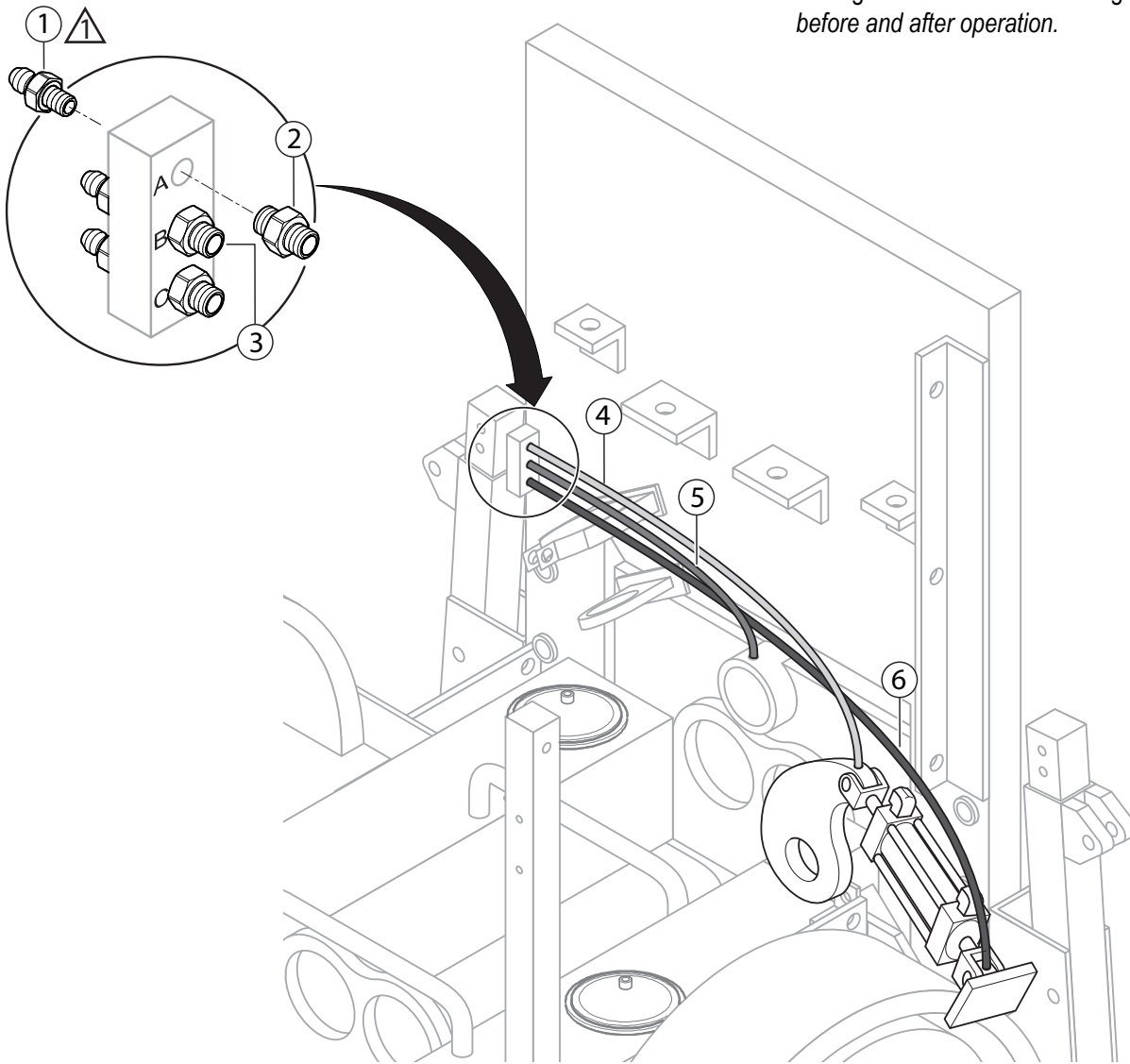

<u>POSITION</u>	<u>LOCATION</u>	<u>LENGTH OF LINES</u>
A	CLEVIS GREASE POINT	34 in. (1.1 m)
B	SWING AXLE BUSHING GREASE POINT	26 in. (.85 m)
C	PIVOT BRACKET GREASE POINT	41 in. (1.5 m)

LUBRICATION PANEL ASSY.

<u>NO.</u>	<u>PART NO.</u>	<u>PART NAME</u>	<u>QTY.</u>	<u>REMARKS</u>
1	EM491701	GREASE FITTING	3	
2	515328	ADAPTOR, FITTING	1	
3	EM510684	GREASE FITTING	2	
4	802639	HOSE, RUBBER	1	
5		STEEL LINE.....	AR.....	OBTAIN LOCALLY
6	EM505516	HOSE, PLASTIC 1/4"	AR.....	1 PC=1 FT

ENGINE COVER ASSY.

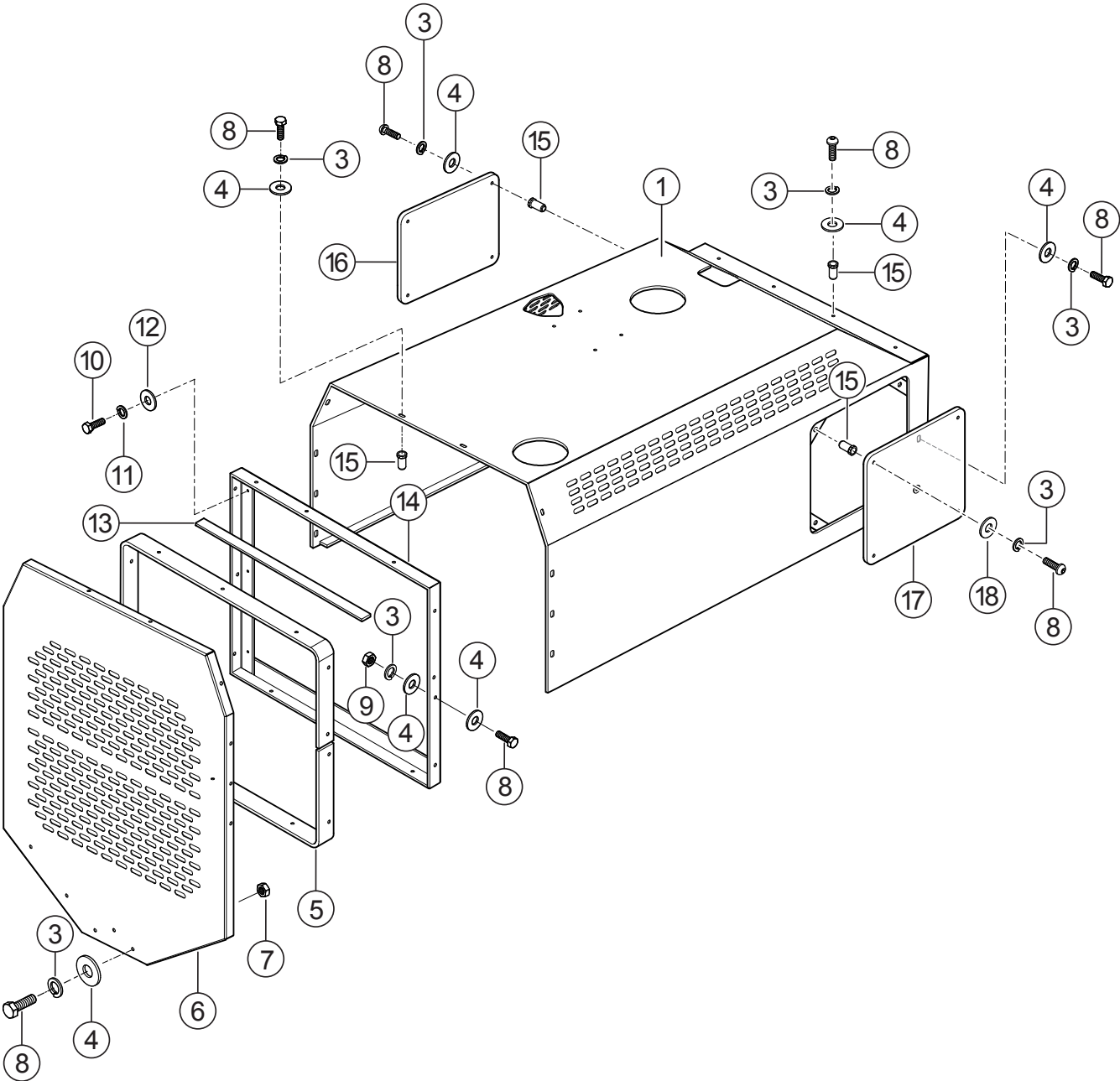

ENGINE COVER ASSY.

<u>NO.</u>	<u>PART NO.</u>	<u>PART NAME</u>	<u>QTY.</u>	<u>REMARKS</u>
1	518761	COVER, ENGINE	1	
3	2101402	WASHER, LOCK 1/4"	AR	
4	100531	WASHER, FLAT, 1/4"	AR	
5	801589	FRAME, VENT	1	
6	801418	COVER, VENT	1	
7	492581	NUT, 1/4-20 NYLON LOCK	12	
8	100443	BOLT, M6 X 20 P-1	AR	
9	2101428	NUT, 1/4-20 NYLON LOCK	AR	
10	100265	BOLT, M8 X 16 P-1.25 GRD8.8	6	
11	030208200	WASHER, LOCK M8	6	
12	100494	WASHER, FLAT M8	6	
13	802662	BRACE, VENT	1	
14	518886	FRAME, VENT, INNER	1	
15	100602	NUT, BLIND M6	27	
16	802666	COVER, ACCESS, ALTERNATOR	1	
17	801351	COVER, ACCESS, FUEL FILTER	1	
18	518761	WASHER, FLAT	1	

HYDRAULIC TANK ASSY.

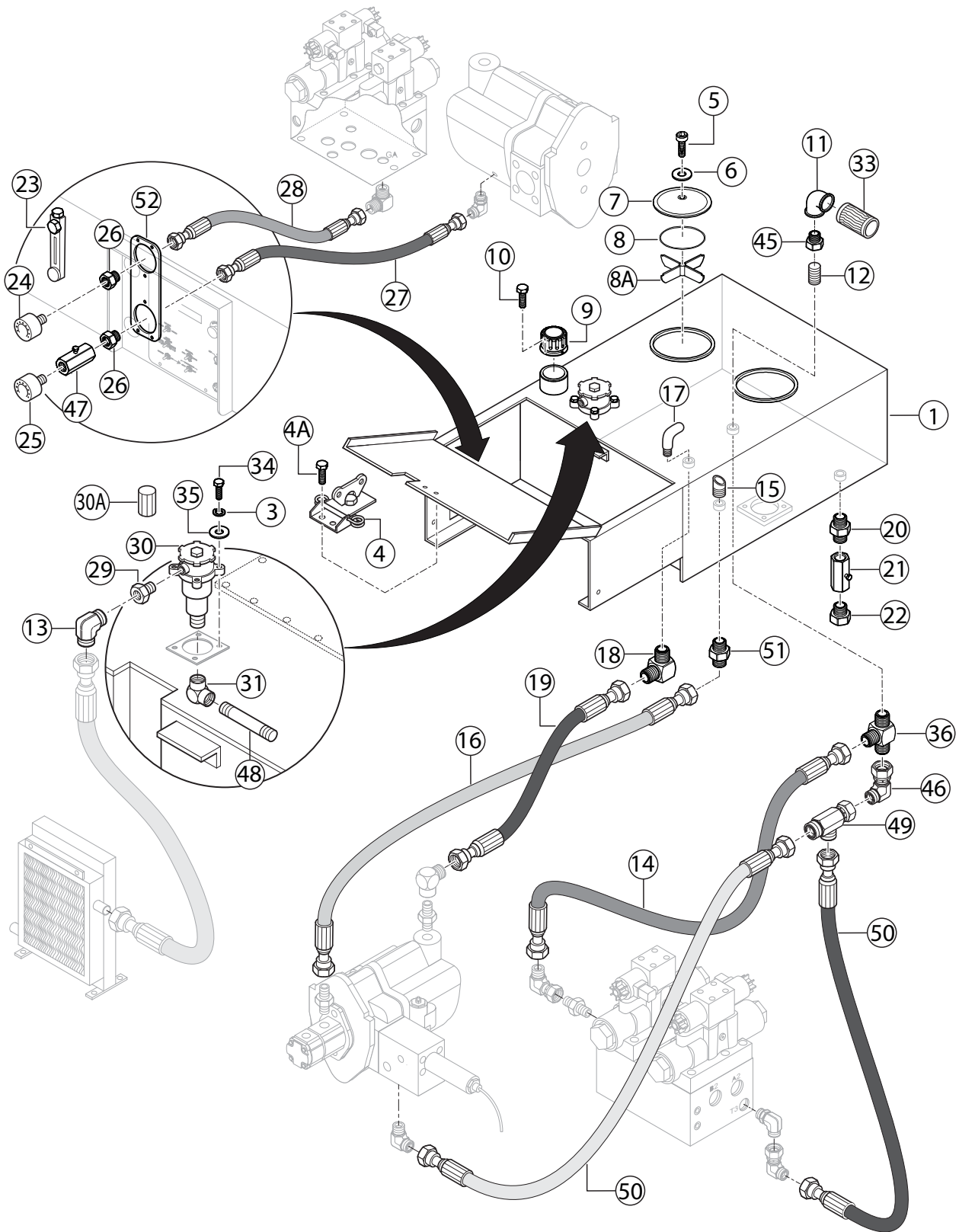

HYDRAULIC TANK ASSY.

<u>NO.</u>	<u>PART NO.</u>	<u>PART NAME</u>	<u>QTY.</u>	<u>REMARKS</u>
1	800273	HYDRAULIC TANK	1	
3	0166 A	WASHER, LOCK 3/8"	4	
4	EM517295	LATCH	1	
4A		BOLT	2	OBTAIN LOCALLY
5	505990	BOLT, 1/2" X 2-1/2"	2	
6	520343	O-RING	2	
7	EM800299	COVER	2	
8	EM800300	O-RING	2	
8A	EM800301	RETAINER	2	
9	EM98263P	CAP ASSY.	1	
10	492267	BOLT, 3/16 X 5/8"	6	
11	EM16433	ELBOW STREET 1-1/2"	1	
12	EM491189	FITTING	1	
13	EM18436	ELBOW, 90° MALE ADAPTER	1	
14	EM514605	HOSE	1	
15	EM514622	FITTING, 1"	1	
16	516876	HOSE	1	
17	EM491189	ELBOW, 3/4"	1	
18	509784	ADAPTER	1	
19	517002	HOSE	1	
20	EM509369	ADAPTER, MALE STRAIGHT	1	
21	491237	GATE VALVE, 1/2" NPT FEMALE	1	
22	506094	PLUG, 1/2" NPT GALVANIZED	1	
23	EM98188	GAUGE, LEVEL AND TEMP.	1	
24	EM97066	GAUGE, 3000PSI, ACCUMULATOR	1	
25	EM97067	GAUGE, 5000PSI, MAIN	1	
26	EM25523	ADAPTER	2	
27	EM509517	HOSE, 4000PSI, MAIN GAUGE	1	
28	EM514602	HOSE, 4000PSI, ACCUM. GAUGE	1	
29	16517	ADAPTER, MALE STRAIGHT	1	
30	EM98112A	FILTER ASSY., RETURN	1	
30A	EM98275	ELEMENT, RETURN FILTER	1	
31	516814	FITTING, 90°	1	
33	EM16513	DIFFUSER	1	
34	EM963610	CAP SCREW, 3/8" NC X 1-1/4" GRD 8	4	
35	3019092	WASHER, FLAT 3/8"	4	
36	EM509343	TEE FITTING	1	
45	516813	BUSHING	1	
46	EM509401	ELBOW	1	
47	EM16414	VALVE NEEDLE	1	
48	EM16516	PIPE 1-1/2"	1	
49	EM509344	TEE	1	
50	EM514604	HOSE HYDRAULIC	2	
51	517029	FITTING, STRAIGHT	1	
52	802671	RETAINING PLATE	1	

ENGINE MOUNTING EXHAUST ASSY.

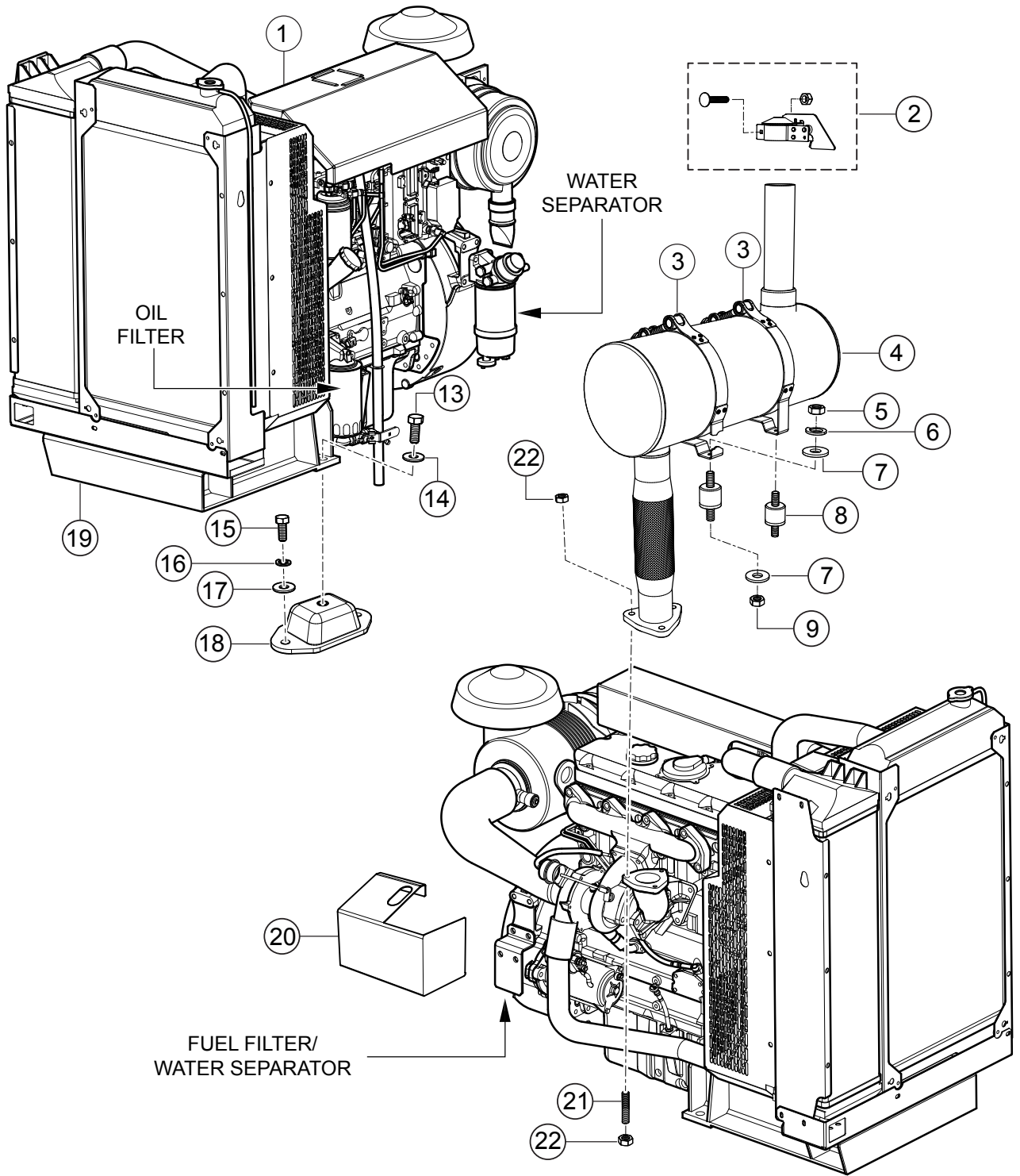

ENGINE MOUNTING EXHAUST ASSY.

<u>NO.</u>	<u>PART NO.</u>	<u>PART NAME</u>	<u>QTY.</u>	<u>REMARKS</u>
1	EM519238	ENGINE, PERKINS 1104D-44TA	1	
2	510897	CAP, EXHAUST PIPE	1	
3	802465	CLAMP, EXHAUST MUFFLER	2	
4	801640	MUFFLER	1	
5	2105164	NUT, 5/16"	4	
6	EM923343	WASHER, LOCK 5/16"	4	
7	EM923057	WASHER, 1/4"	8	
8	801637	CUSHION, RUBBER	4	
9	2105164	NUT, 5/16"	4	
13	492406	BOLT	5	
14	EM506109	WASHER, FLAT 5/8"	5	
15	EM963102	CAP SCREW HX HD 1/2"NC X 1-1/4"	10	
16	6109180	WASHER, LOCK 1/2"	10	
17	6109170	WASHER, FLAT 1/2"	10	
18	518883	MOUNT, ENGINE FOOT	5	
19	800311	BASE, RADIATOR MOUNT	1	
20	801924	COVER, HEAT SHIELD	1	
21	2313C077	STUD	3	
22	2318A634	NUT	6	

ENGINE AIR FILTER ASSY.

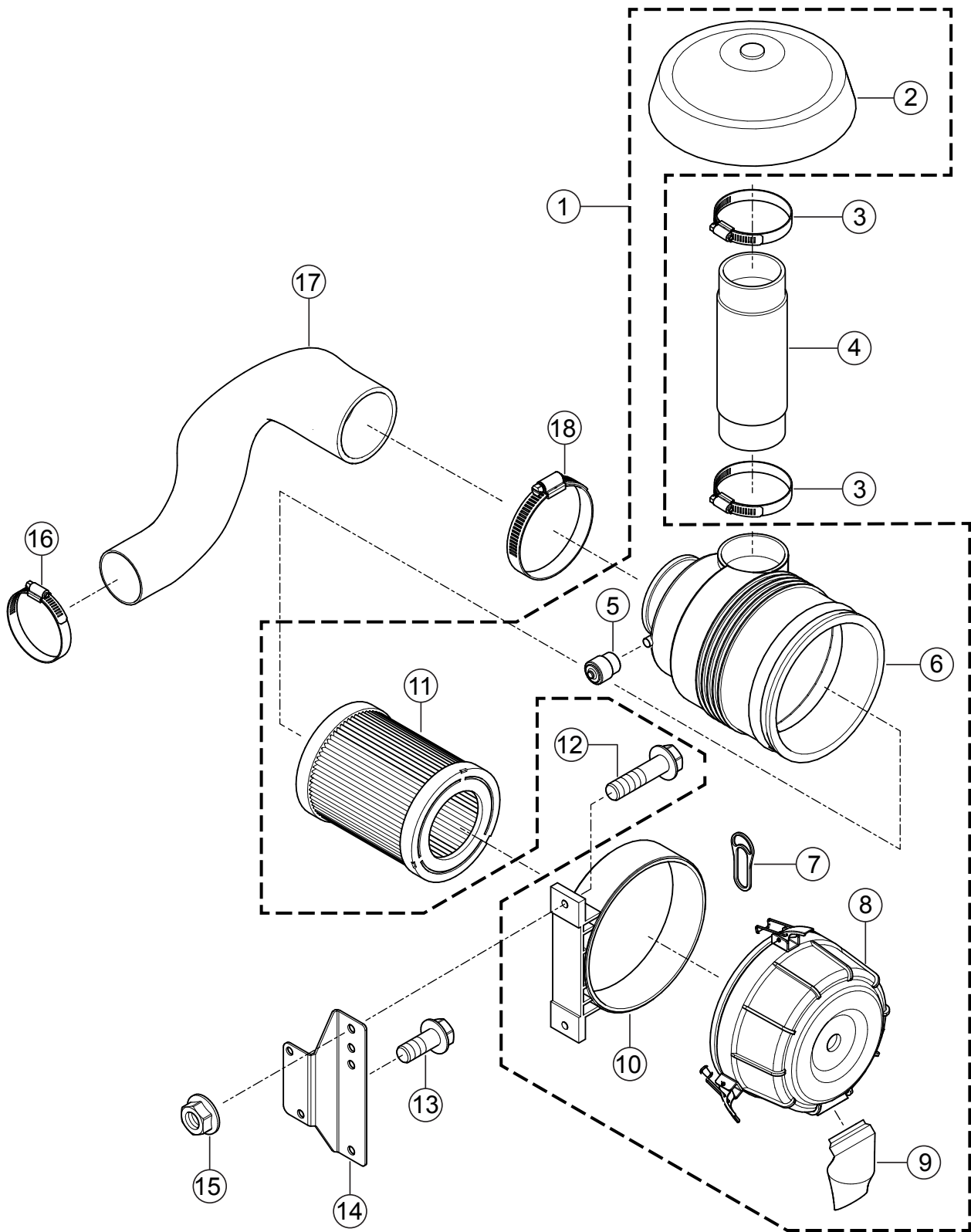

ENGINE AIR FILTER ASSY.

<u>NO.</u>	<u>PART NO.</u>	<u>PART NAME</u>	<u>QTY.</u>	<u>REMARKS</u>
1	2652C202	AIR FILTER ASSY.....	1.....	INCLUDES ITEMS W/\$
2\$	26510411	CAP, AIR FILTER	1	
3	521311	CLAMP	2	
4	800267	PIPE, EXHAUST EXTENSION	1	
5\$	26510385	INDICATOR, AIR FILTER	1	
6\$		AIR FILTER BODY.....	1.....	NOT SOLD SEPERATELY
7\$	26510407	RUBBER STRAP	1	
8\$		COVER, AIR FILTER	1.....	NOT SOLD SEPERATELY
9\$	26510386	VALVE, AIR FILTER	1	
10\$	26510382	MOUNTING BRACKET	1	
11\$	26510380	AIR FILTER	1	
12	2314H005	SCREW	2	
13	2314J002	SCREW	2	
14	3653A051	BRACKET	1	
15	2318A603	NUT	2	
16	21825194	CLAMP	1	
17	3783R007	HOSE, AIR FILTER	1	
18	0180074	CLAMP	1	

THROTTLE ASSY.

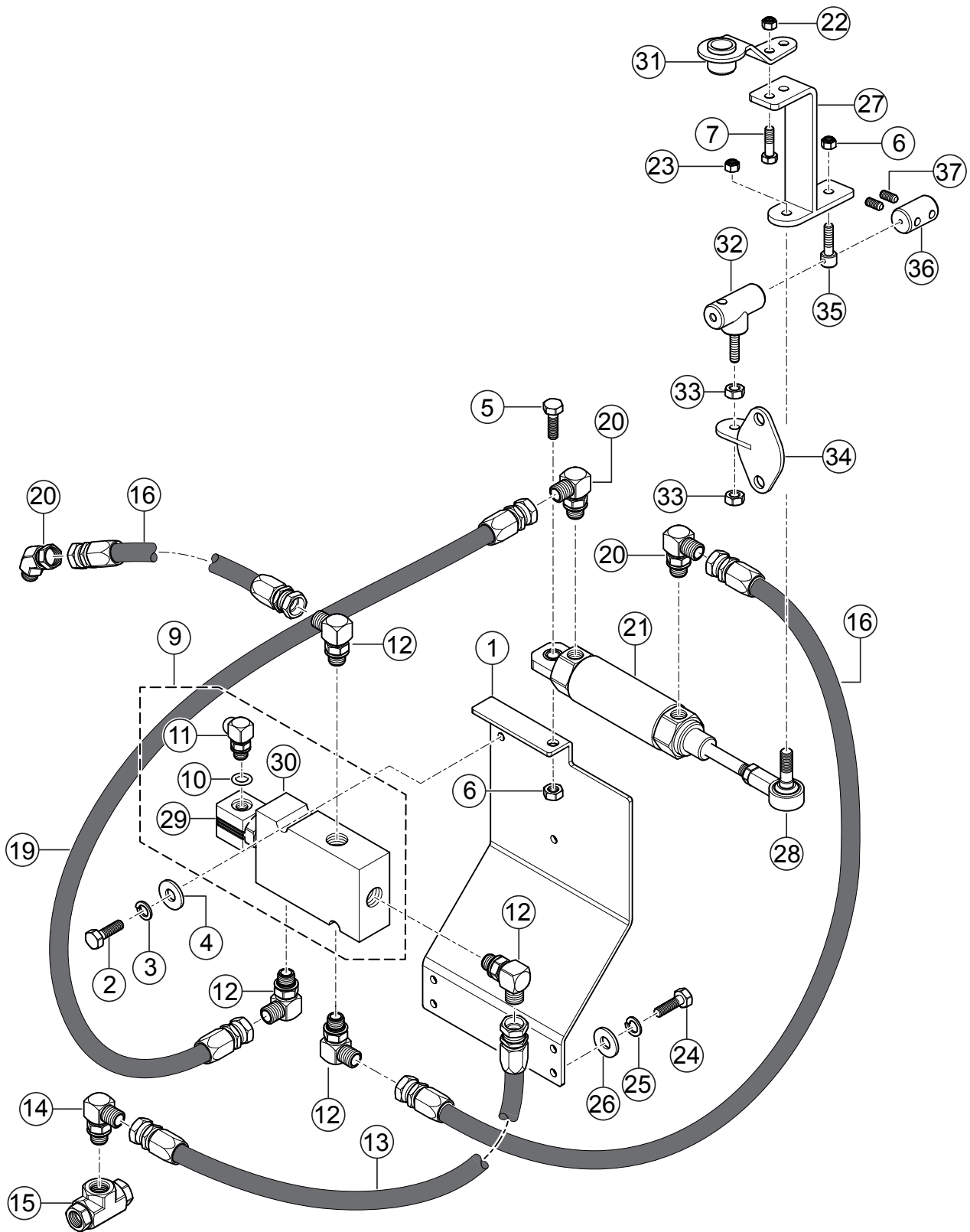

THROTTLE ASSY.

<u>NO.</u>	<u>PART NO.</u>	<u>PART NAME</u>	<u>QTY.</u>	<u>REMARKS</u>
1	800377	SUPPORT BASE, ACCELERATOR	1	
2	EM167	BOLT, 1/4-20 X 1-3/4" SOCK. HD.	2	
3	2101402	WASHER, LOCK 1/4"	2	
4	EM923057	WASHER, 1/4"	2	
5	512185	SCREW, HHC 1/4-20 X 1-3/4"	1	
6	492581	NUT, HEX 1/4"	1	
7	EM506599	BOLT, HEX 6MM X 15	2	
9	EM98168	VALVE SOLENOID, THROTTLE BLOCK.....	1.....	INCLUDES ITEMS W/\$
10\$	EM98167	SEAL CONNECTOR	1	
11\$	EM98166	CONNECTOR, DIN PG9	1	
12	EM25429	ELBOW, ADAPTER 90° MALE	7	
13	516875	HOSE, 500MM LONG	1	
14	EM50449	FITTING ELBOW, 90°	1	
15	EM25577	TEE STREET, SAE1404	1	
16	EM509366	HOSE, 13-3/4" LONG	2	
19	EM25576	HOSE, 20" LONG	1	
20	EM50449	ELBOW, ADAPTER 90° MALE	3	
21	EMCC700	HYDRAULIC CYLINDER	1	
22	100078	NUT, M6 P-1 NYLON INSERT	2	
23	508451	NUT, LOCK 1/4-28 NF	1	
24	EM506886	BOLT, M8X20 X 1-1/4"	4	
25	030208200	WASHER, LOCK M8	4	
26	040150080	WASHER, FLAT SS M8	4	
27	800141	LEVER, ACCELERATOR	1	
28	516487	END, ROD	1	
29\$	EM98228	COIL, 12V	1	
30\$	EM98232	CARTRIDGE VALVE	1	
31	EM505201	SHOCK MOUNT	1	
32	520180	PIVOT, ACCELERATOR LINKAGE	1	
33	2101428	NUT, HEX 1/4-20	2	
34	801838	BASE, MOUNTING	1	
35	513213	GUIDE, THROTTLE CABLE	1	
36	802587	ANCHOR, THROTTLE CABLE GUIDE	1	
37	492466	SET SCREW, 1/4"NC X 1/2"	2	

OIL FILTER-WATER SEPARATOR ASSY.

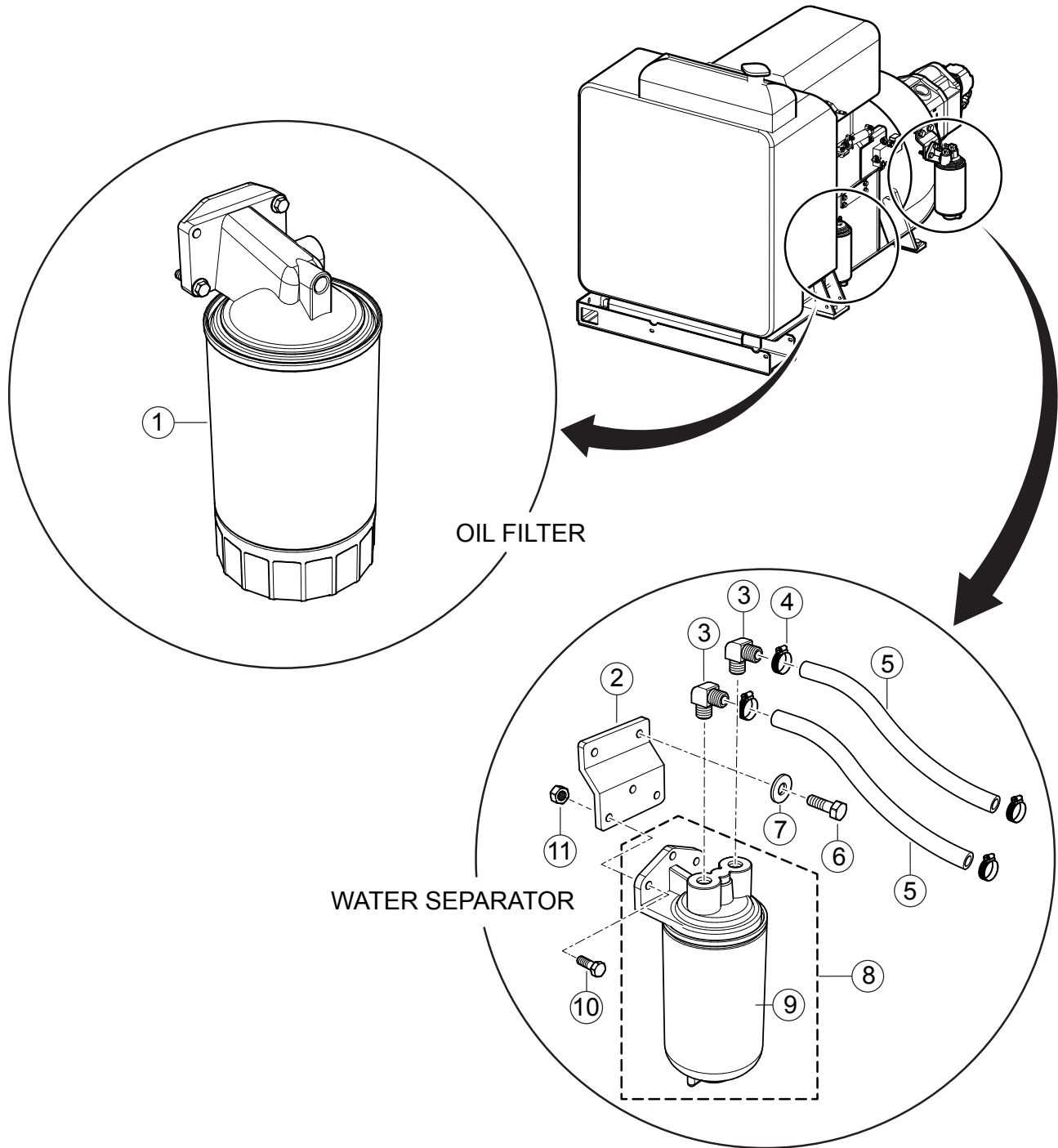

OIL FILTER-WATER SEPARATOR ASSY.

<u>NO.</u>	<u>PART NO.</u>	<u>PART NAME</u>	<u>QTY.</u>	<u>REMARKS</u>
1	2654407	OIL FILTER	1	
2	802661	BRACKET, MTG. WATER SEPARATOR	1	
3	514560	ELBOW, 90°	2	
4	506208	CLAMP	4	
5	514563	HOSE, 4FLH 5/16".....	AR.....	1 PC=1 FT
6	100286	BOLT, M12 X 25P-1.75	2	
7	6109180	WASHER, LOCK 1/2"	2	
8	EM16747	WATER SEPARATOR ASSY.....	1.....	INCLUDES ITEM W/\$
9\$	EM167472	FILTER, WATER SEPARATOR	1	
10	EM963057	CAP SCREW, 3/8" X 1-1/2"	3	
11	EM969013	NUT, NYLOK	3	

HYDRAULIC PUMP ASSY.

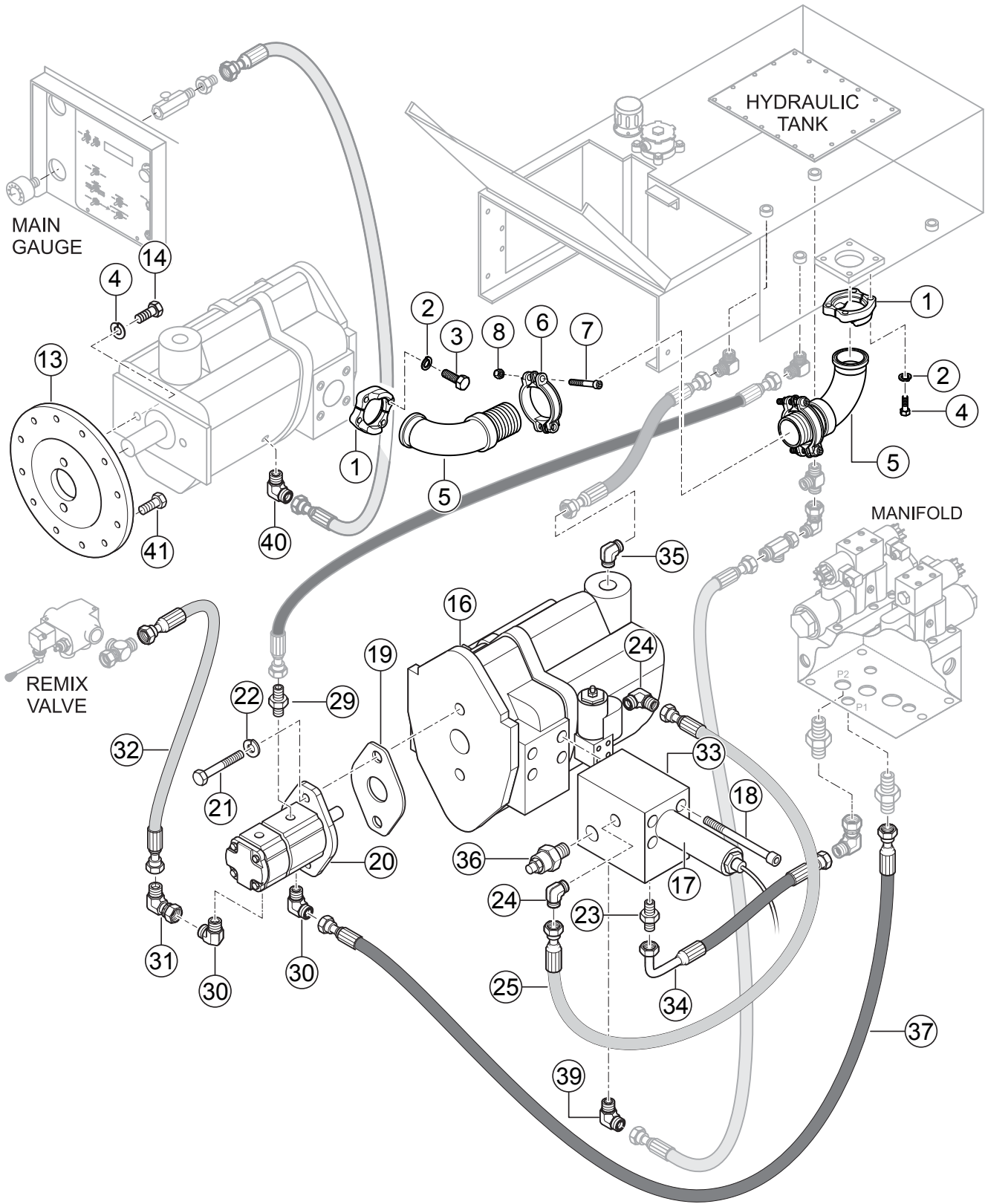

HYDRAULIC PUMP ASSY.

<u>NO.</u>	<u>PART NO.</u>	<u>PART NAME</u>	<u>QTY.</u>	<u>REMARKS</u>
1	EM514719	FLANGE, SUCTION PIPE	2	
2	6109180	WASHER, LOCK 1/2"	8	
3	EM963692	CAP SCREW, HHCS 1/2-13 X1-1/2" GRD 5	4	
4	492444	CAP SCREW, 1/2"NF X 1-1/4" GRD 5	4	
5	801874	SUCTION ELBOW	2	
6	810875	CLAMP, SUCTION ELBOW	2	
7	511428	SCREW, ALLEN HD 1/2-13 X 3" GRD 5	4	
8	492584	NUT, LOCK 1/2"NC, NYLOK GRD 5	4	
13	EM519239	COUPLER, ENGINE ASSY.	1	
14	EM510902	BOLT, 1/2" 1-1/2"	2	
16	EM98257	PUMP, MAIN 100CC	1	
17	EM98273	FLOW CONTROL VALVE	1	
18	511428	SCREW, ALLEN HD. 1/2-13 X 3	4	
19	EM16190	GASKET	1	
20	EM98107	PUMP, SECONDARY	1	
21	EM963610	BOLT, 3/8" X 1"	2	
22	0166 A	WASHER, LOCK 3/8"	2	
23	EM509796	ADAPTER, STRAIGHT	1	
24	EM25429	ELBOW ADAPTER	2	
25	516875	HOSE, 4000 PSI SENSOR	1	
29	EM25498	ADAPTER, STRAIGHT	1	
30	EM16524	ELBOW ADAPTER 90° MALE	2	
31	503200	ELBOW ADAPTER	1	
32	EM514601	HOSE, 2000 PSI, REMIX VALVE	1	
33	EM517650	MANIFOLD W/MOTORIZED FLOW CTRL.	1	
34	EM517032	HOSE, MAIN MANIFOLD	1	
35	EM25459	ELBOW	1	
36	EM98276	VALVE, MAIN RELIEF	1	
37	EM514608	HOSE	1	
39	EM25459	ELBOW	1	
40	EM25429	ELBOW ADAPTER	1	
41	54812	SCREW, ALLEN HD. CAP	12	

MANIFOLD ASSY.

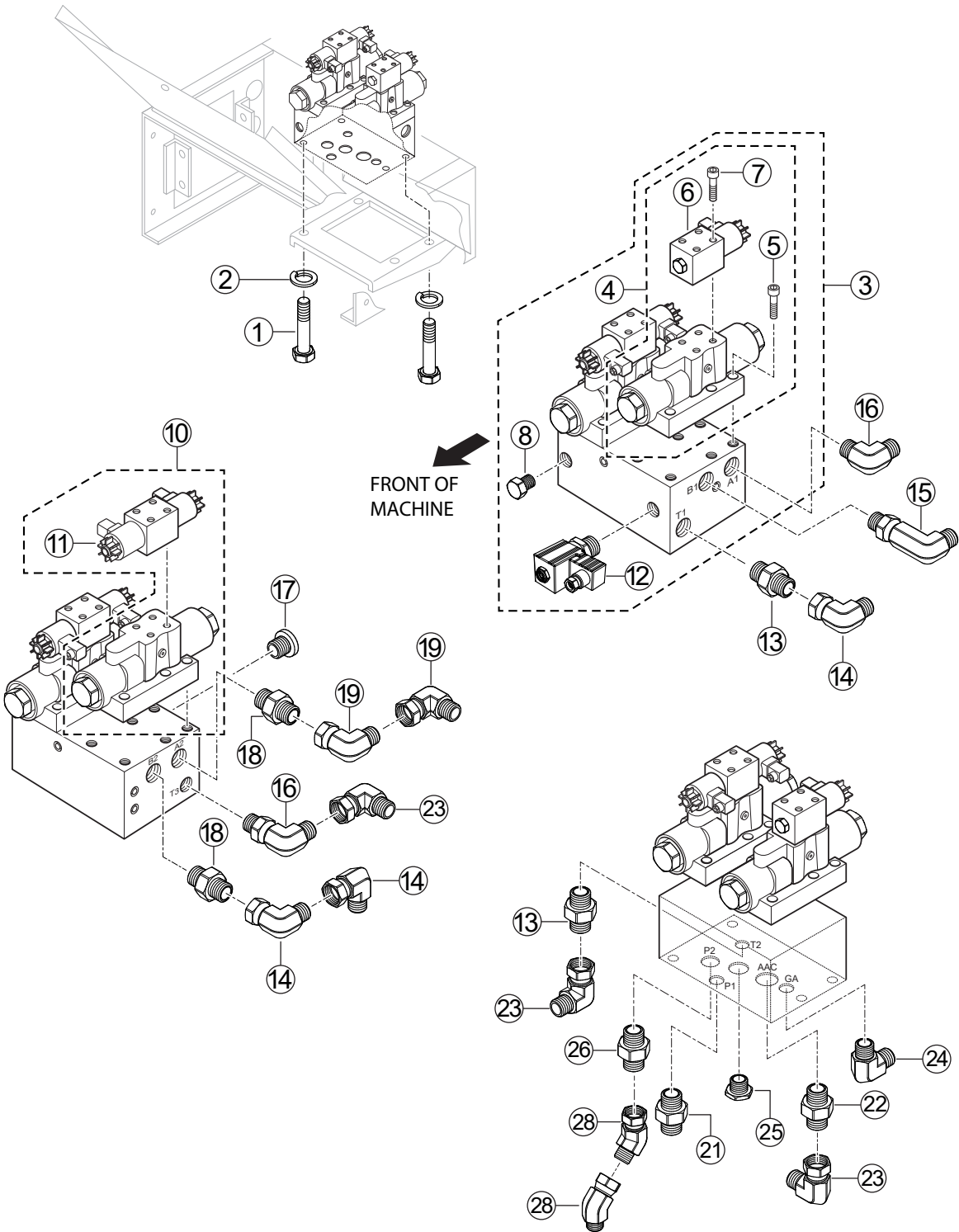

MANIFOLD ASSY.

<u>NO.</u>	<u>PART NO.</u>	<u>PART NAME</u>	<u>QTY.</u>	<u>REMARKS</u>
1	EM963102	BOLT, 1/2" X 1-1/4"	4	
2	6109180	WASHER, LOCK 1/2"	4	
3	EM98261	MANIFOLD ASSY.	1	INCLUDES ITEMS W/%
4%	EM98220	CYCLING VALVE, SWING W/PILOTS.....	1	INCLUDES ITEMS W/#
5%#	EMBK227	BOLT, SHCS 1/2" X 2-1/4"	12	
6%#	EM98223	PILOT VALVE, SHUTTLE	1	
7%#	EMBK2097	BOLT, SHCS 1/2" X 1-1/4"	8	
8%	EM98227	CHECK VALVE	1	
10	EM98221	CYCLING VALVE, MAIN.....	1	INCLUDES ITEM W/\$
11\$	EM98222	PILOT VALVE, MAIN CYL.	1	
12%	EM98307	CARTRIDGE ASSY., ACCUM. UNLOADER	1	
13	EM25498	FITTING HYDRAULIC, ELBOW	3	
14	EM509401	ELBOW	3	
15	EM514488	ADAPTER	1	
16	EM25459	ELBOW, 3/4" 90°	2	
17	519663	ADAPTER, PLUG	1	
18	EM514231	ADAPTER	2	
19	EM514489	ADAPTER	2	
20	EM506193	ADAPTER	1	
21	EM506193	ADAPTER	1	
22	EM25462	STRAIGHT CONNECTOR	1	
23	EM509353	ELBOW	3	
24	EM25497	FITTING, ELBOW	1	
25	EM98227	CHECK VALVE	1	
26	EM509796	ADAPTER, STRAIGHT	1	
27	EM517149	ADAPTER, ELBOW 90°	1	
28	518198	ADAPTER, ELBOW 45°	2	

CONTROL BOX ASSY.

<u>NO.</u>	<u>PART NO.</u>	<u>PART NAME</u>	<u>QTY.</u>	<u>REMARKS</u>
1		CONTROL BOX ASSY.	1.....	CONTACT MQ PARTS DEPT.
2	0202	BOLT, 5/16-18 X 1" ZINC	4	
3	EM923023	WASHER, FLAT 5/16"	8	
4	2105164	NUT, 5/16"	4	
7	EM98206	IGNITION SWITCH ASSY.	1.....	INCLUDES ITEM W/\$
8\$	EM98206K	KEY, IGNITION	1	
9		SCREW.....	6.....	OBTAIN LOCALLY
10		WASHER	6.....	OBTAIN LOCALLY
11	EM97068	RECEPTACLE, REMOTE	1	
12	EM98120	FLOW DIRECTION SWITCH ASSY.	1	
13	EM98119	MAIN CONTROL SWITCH ASSY.	1	
14	EM98121	AUTO/JOG SWITCH ASSY.	1	
15	EM98122	JOG A/B SWITCH ASSY.	1	
16	EM517177	EMERGENCY STOP SWITCH ASSY.	1.....	INCLUDES ITEM W/#
17#	EM517186	CONTACT BLOCK, EMERG. SWITCH	1	
19	EM98122	VOLUME SWITCH ASSY.	1	
20	EM98122	RESET SWITCH ASSY.	1	
21	EM98122	SCROLL SWITCH ASSY.	1	

CONTROL BOX HARNESS ASSY.

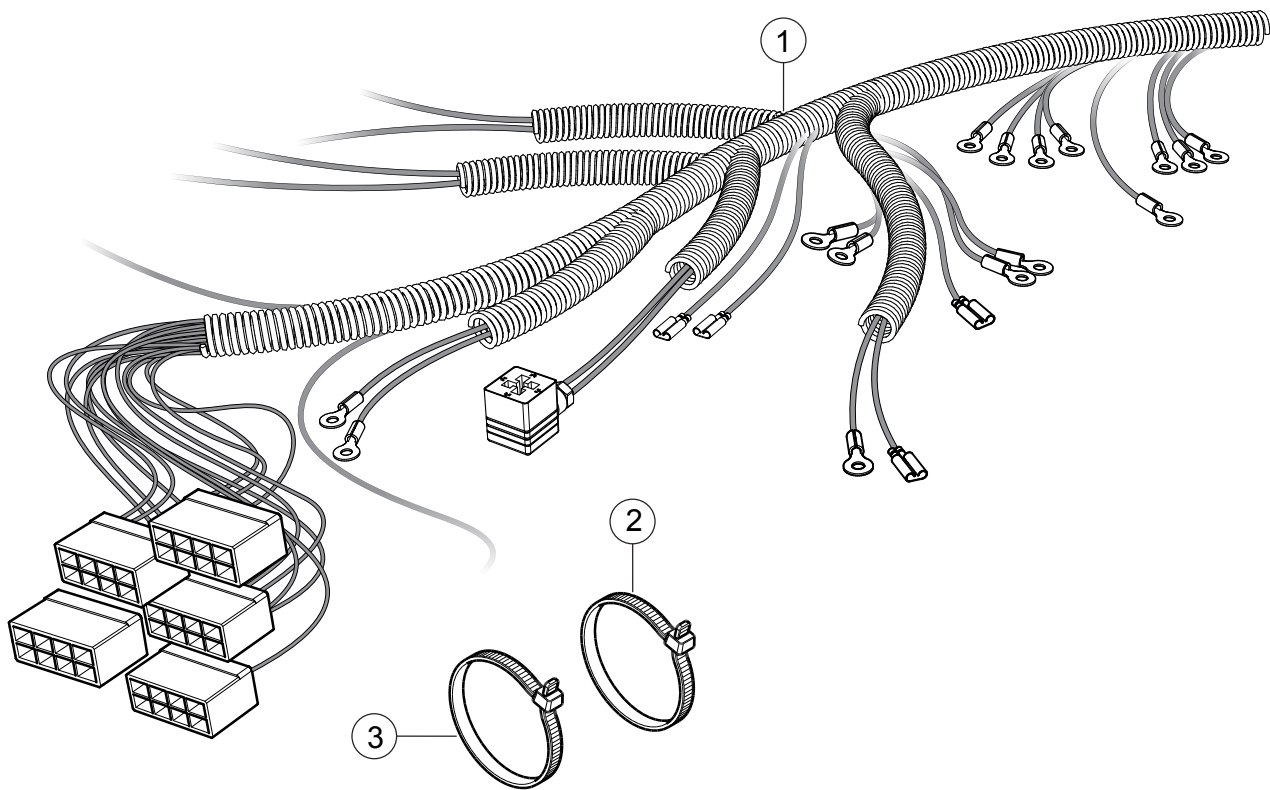

CONTROL BOX HARNESS ASSY.

<u>NO.</u>	<u>PART NO.</u>	<u>PART NAME</u>	<u>QTY.</u>	<u>REMARKS</u>
1	EM800107	WIRE HARNESS, MAIN	1	
2	491030	WRAP, TIE 2.5 X 142MM	5	
3	EM504505	WRAP, TIE 4.6 X 360MM	2	

REMOTE CONTROL CABLE ASSY.

<u>NO.</u>	<u>PART NO.</u>	<u>PART NAME</u>	<u>QTY.</u>	<u>REMARKS</u>
1\$	EM16753	JUNCTION BOX	1	
2\$	EM16754	SWITCH	1	
2A\$	EM97075	SWITCH	1	
3\$	EM491897	CONNECTOR, RING 3/16"	4	
4\$	EM16756	GUARD SWITCH, ALUMINUM.	2	
5\$	EM26791	SEAL, GRIP CORD	1	
6\$	EM26790	CORD, MX P/E 25'	1	
7	EM26793	ADAPTER, CORD GRIP 1/2"	1	
8	EM97065	CORD, 100', REMOTE CONTROL.....	1.....	OPTION
9	EM97099	CABLE REMOTE CONTROL ASSY., 25'	1.....	INCLUDES ITEMS W/\$

HYDRAULIC STABILIZER ASSY.(OPTIONAL)

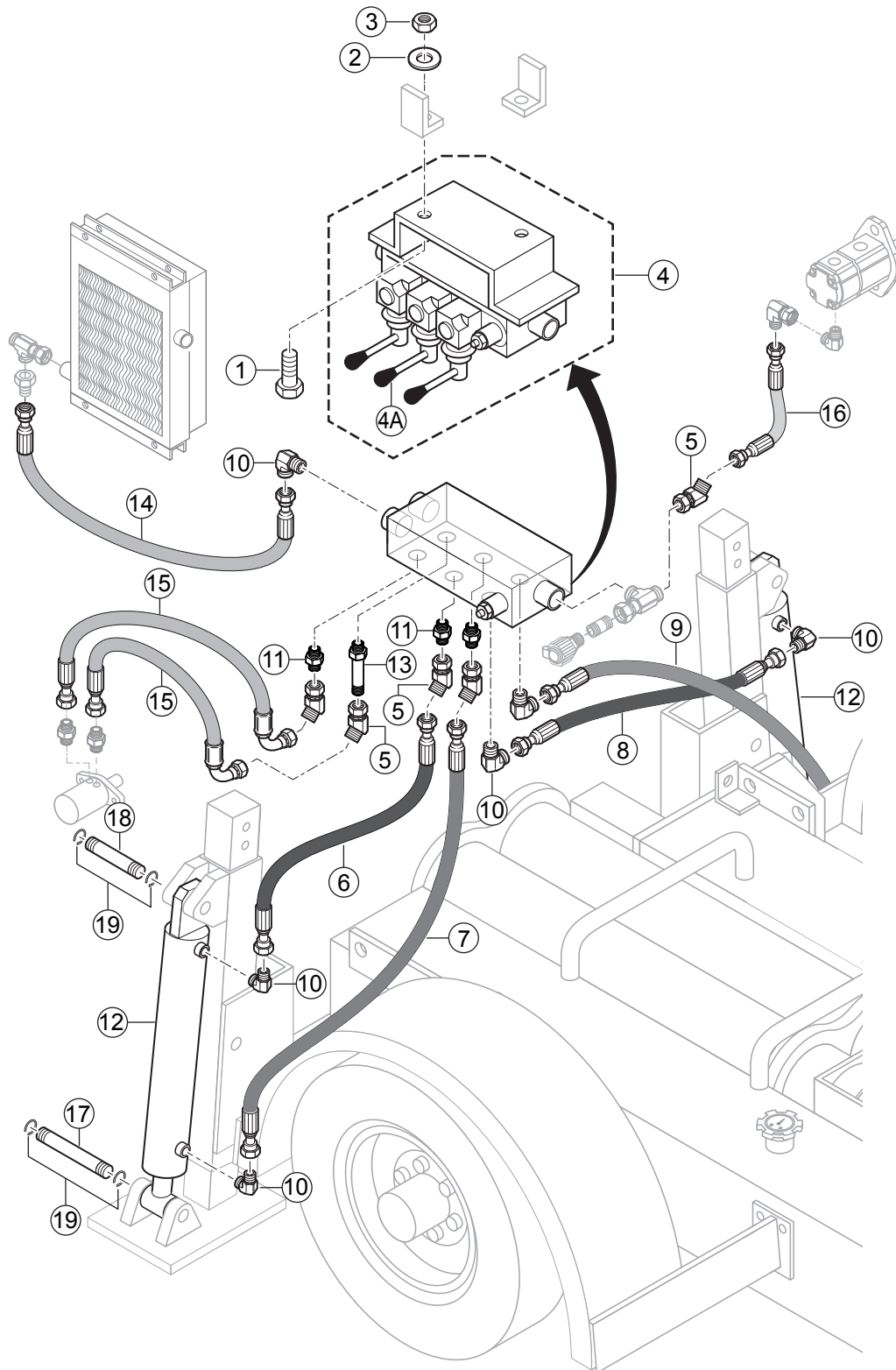

HYDRAULIC STABILIZER ASSY.(OPTIONAL)

<u>NO.</u>	<u>PART NO.</u>	<u>PART NAME</u>	<u>QTY.</u>	<u>REMARKS</u>
1		BOLT.....	2.....	OBTAIN LOCALLY
2		WASHER	2.....	OBTAIN LOCALLY
3		NUT.....	2.....	OBTAIN LOCALLY
4	EM98046	VALVE REMIXER W/3 LEVERS	1.....	INCLUDES ITEM W/\$
4A\$	EM98047	HANDLE, DIRECTIONAL VALVE	3	
5	503200	FITTING, 45°	5	
6	517101	HOSE	1	
7	517102	HOSE	1	
8	517103	HOSE	1	
9	517104	HOSE	1	
10	EM512655	ADAPTER, 90°	7	
11	EM25509	FITTING, STRAIGHT	3	
12	EM516382	HYDRAULIC CYLINDER	2	
13	EM517107	FITTING, STRAIGHT	1	
14	517105	HOSE	1	
15	517100	HOSE	1	
16	517106	HOSE	1	
17	517153	PIPE	2	
18	517154	PIPE	2	
19	JISB2804C25	RING, RETAINING M25	8	

FUEL-WATER SEPARATOR ASSY.

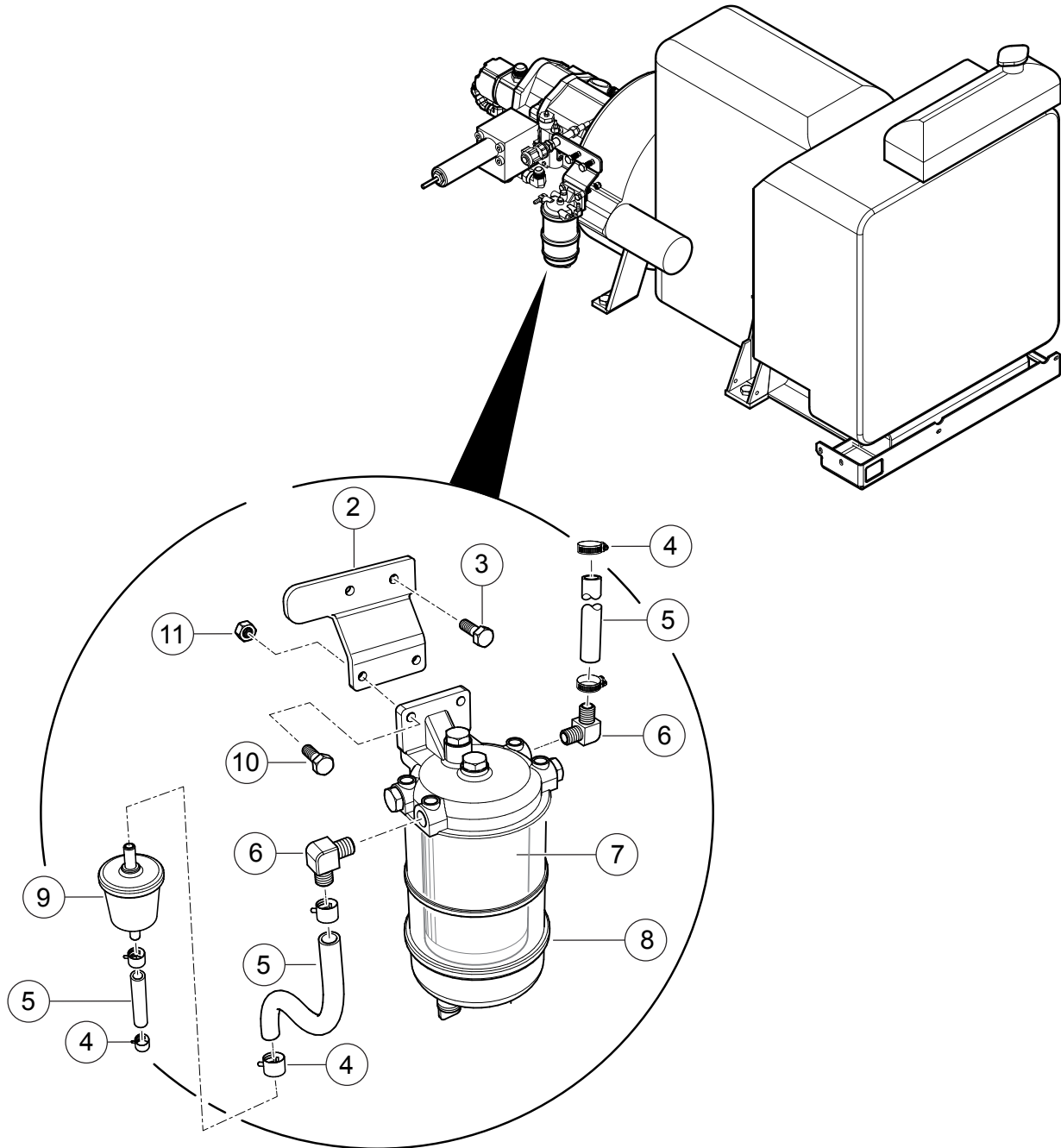

FUEL-WATER SEPARATOR ASSY.

<u>NO.</u>	<u>PART NO.</u>	<u>PART NAME</u>	<u>QTY.</u>	<u>REMARKS</u>
2	803182	BRACKET, FUEL/WATER SEPARATOR	1	
3	100286	BOLT, M12 X 25P-1.75	2	
4	506208	CLAMP	6	
5	514536	HOSE, 4FLH 5/16".....	AR	1 PC=1 FT
6	514560	ELBOW, 90°	2	
7	26560201	FUEL FILTER W/O-RING	1	
8	2656F837	BOWL, PLASTIC F/W SEPARATOR	1	
9	EM20763	FILTER, FUEL IN-LINE	1	
10	EM963057	CAP SCREW, 3/8" X 1-1/2"	2	
11	EM969013	NUT, NYLOK	2	

FUSES AND RELAYS ASSY.

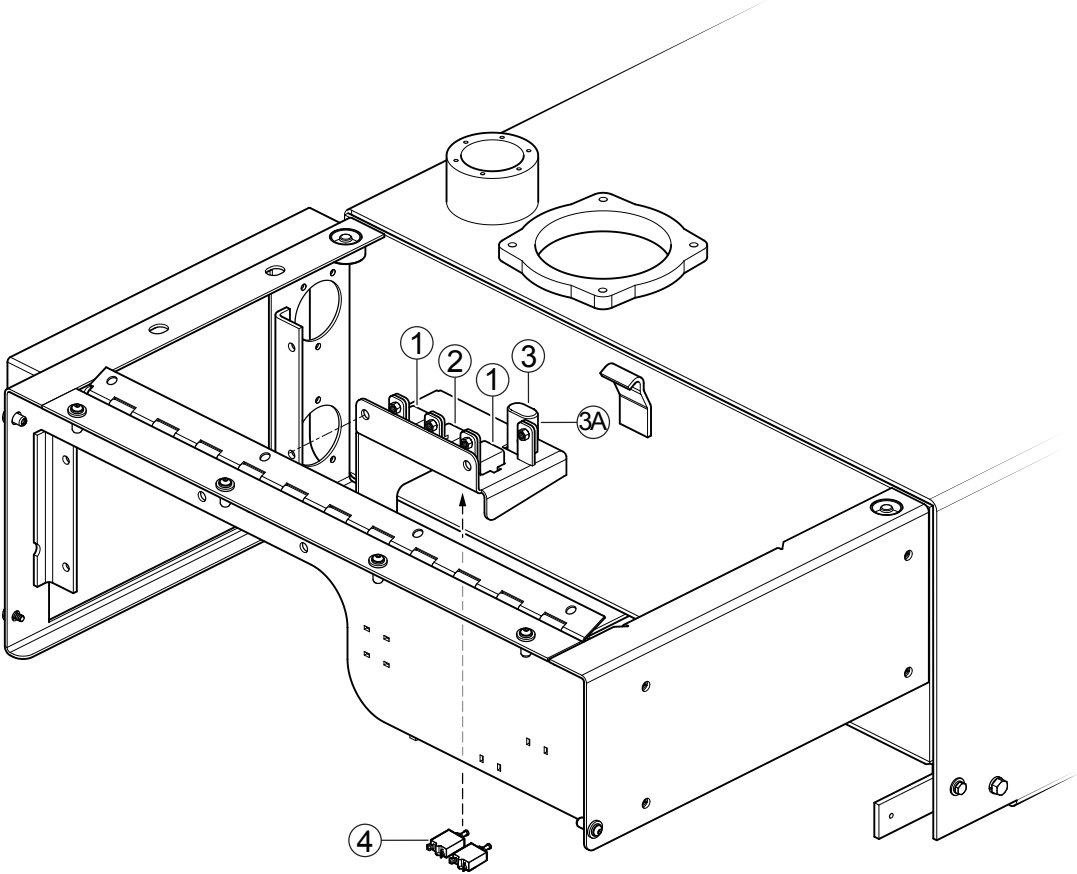

FUSES AND RELAYS ASSY.

<u>NO.</u>	<u>PART NO.</u>	<u>PART NAME</u>	<u>QTY.</u>	<u>REMARKS</u>
1	EM802378	RELAY, 40 AMP, FAN	2	
2	EM802515	RELAY, 80 AMP, ENG. PRE-HEAT	1	
3	EM98066	FUSE HOLDER, 30 AMP MAIN	1	
3A	23284300	FUSE, 30 AMP ATC/ATO	1	
4	515848	CIRCUIT BREAKER, 50 AMP	2	

PARTS MANUAL

HERE'S HOW TO GET HELP

PLEASE HAVE THE MODEL AND SERIAL
NUMBER ON-HAND WHEN CALLING

UNITED STATES

Multiquip Inc.

(310) 537- 3700
6141 Katella Avenue Suite 200
Cypress, CA 90630
E-MAIL: mq@multiquip.com
WEBSITE: www.multiquip.com

CANADA

Multiquip

(450) 625-2244
4110 Industriel Boul.
Laval, Quebec, Canada H7L 6V3
E-MAIL: infocanada@multiquip.com

UNITED KINGDOM

Multiquip (UK) Limited Head Office

0161 339 2223
Unit 2, Northpoint Industrial Estate, Globe Lane,
Dukinfield, Cheshire SK16 4UJ
E-MAIL: sales@multiquip.co.uk

© COPYRIGHT 2026, MULTIQUIP INC.

Multiquip Inc. and the MQ logo are registered trademarks of Multiquip Inc. and may not be used, reproduced, or altered without written permission. All other trademarks are the property of their respective owners and used with permission.

This manual MUST accompany the equipment at all times. This manual is considered a permanent part of the equipment and should remain with the unit if resold.

DISCLAIMER: Product features, descriptions, and specifications are based on published information at the time of publication and are subject to change at any time without notice. Multiquip Inc. and its affiliates reserve the right to change specifications, features, design, and descriptions of products at any time without notice.

