



Service Bulletin No. LT20070720
Subject: Insufficient Welds in A-Frame
Model: LT-12D
Product Group: Light Tower/Generator
Date: July 20, 2007

SERVICE BULLETIN **Group: LT**

THIS SERVICE BULLETIN IS MANDATORY!

Series/Parts Affected:
All LT-12D series Light Towers within VIN range
Machines Affected/Trailer Vehicle Identification Number (VIN)
LT-12D: 904435 to 904772
LT-12D50SA: 904428 to 904712

SERVICE INFORMATION

MANDATORY UPDATE: FAILURE TO FOLLOW INSTRUCTIONS MAY LEAD TO INJURY OR DEATH AND CAUSE SEVERE UNIT DAMAGE!

Problem:

- Multiquip has become aware that improper loading techniques used by some transportation companies may place a severe load on the frame of the light tower and make it susceptible to weld fatigue.
- This condition may cause the frame to **sag** during transport and **may lead to injury or death and severe unit damage!**

Solution: Reinforce welds in and around where the A-frame joins the trailer.

Action Required: AS A PRECAUTION, ALL LT-12D SERIES LIGHT TOWERS WITHIN THE RANGES LISTED ABOVE REQUIRE INSPECTION AND ADDITIONAL WELDING TO REINFORCE THE TRAILER FRAME. Immediately locate any light towers that are deployed (in use) and remove from service until necessary rework is completed. A lockout device is recommended to prevent the light towers from being towed.

Units requiring transportation should **NOT** be towed over the road, street or highway until the necessary updates are completed. Use only a **flatbed trailer** if transport is required.

Action Required: See following pages for inspection and repair procedures.

PARTS INFORMATION			
Quantity	Part #	Description	Remarks
N/A	N/A	N/A	

INSTRUCTIONS FOR SAFELY TRANSPORTING LIGHT TOWER

To minimize risk of damage occurring to the light tower, Multiquip recommends the following procedure when transporting on a flatbed trailer truck.

1. Load the unit on a flatbed trailer truck (Figure 1) with the front jack stand retracted and in the horizontal position so the foot does not make contact with the trailer deck floor.

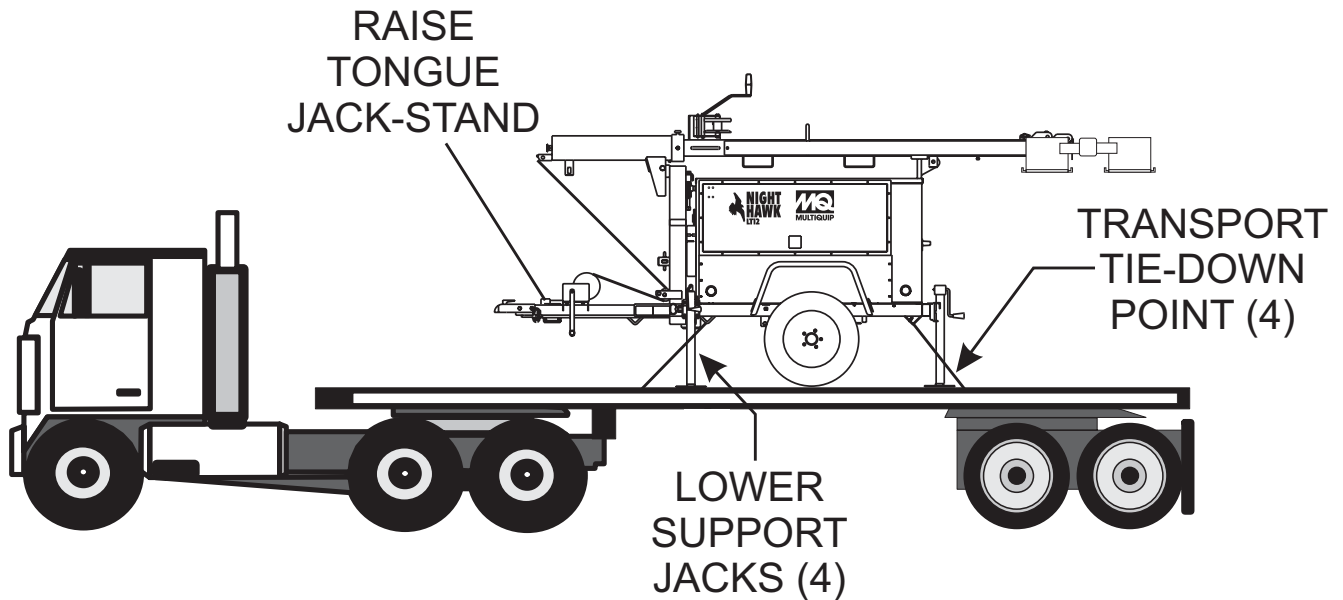

Figure 1. Light Tower Transport

2. The two side (left and right) and two rear jack stands should be in the vertical position slightly extended so each foot makes contact with the trailer deck floor.
3. Straps/Chains should be routed through the tie-down points located beneath each corner of the cabinet. This will allow force to be applied evenly to the front and rear of the machine.

DO NOT SECURE THE UNIT BY RUNNING A STRAP OR CHAIN OVER THE TONGUE OF THE LIGHT TOWER. THIS MAY CAUSE SEVERE DAMAGE TO THE UNIT!

BACKGROUND INFORMATION

Welds at the front end (A-frame) of the light tower are *single-pass* welds. For reinforcement, *triple-pass* welds are required where the angle meets the outrigger tube (mainframe). Circles indicate the critical inspection areas. See Figure 2.

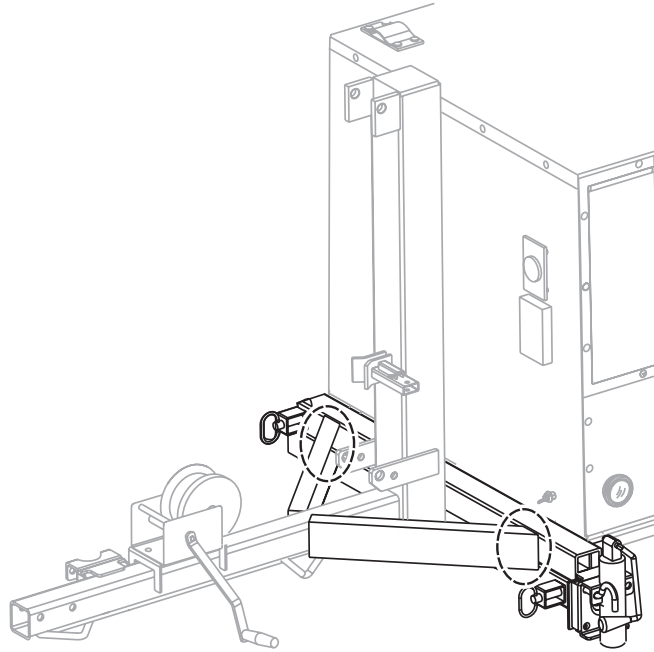

Figure 2

Stresses incurred from improper transport can weaken single-pass welds leading to fatigue and possible separation of the A-frame from the mainframe of the unit.

One method of identifying light towers with single-pass welds is the appearance of a chamfered, or beveled, corner where the A-frame meets the trailer outrigger tube (mainframe).



Figure 3 at right shows a single-pass weld with chamfered corner (circled).

Figure 3. Single Pass Weld

A triple-pass weld will appear similar to the photo at right. Notice the appearance of more weld material in the outside angle. A single pass weld (not shown) can be found on the INSIDE of the angle. If you have questions regarding any of the information in this bulletin contact Multiquip to arrange inspection by an authorized representative.

Figure 4 (right) shows a triple-pass weld. Note the chamfered corner mentioned above is not visible if a triple-weld pass was performed.



Figure 4. Triple Pass Weld

INSTRUCTIONS

WORK SAFELY!

This procedure should be performed only by a **qualified welder** following safe and approved welding techniques.

ALL LT12-series Light Towers within the specified VIN number range listed on page 1 of this bulletin require this update. Use the following guidelines to ensure repairs are performed to factory specifications.

Two sets of instructions are provided. One set addresses how to repair machines that show signs of weld fatigue. Another set addresses applying additional weld to a machine that does NOT exhibit signs of weld fatigue.

Before welding on light tower frame, place light tower in an open work area free of any obstructions and overhead power lines. Make certain light tower is placed on secure level ground and lower each of the stabilization jacks to prevent tipping. Place chock blocks under both wheels to prevent rolling.

CAUTION!

The work detailed in the WELDING INSTRUCTIONS section of this bulletin should be done only by a qualified welder. If a qualified welder is not available to perform the work, or if you have any questions regarding the repair procedure, immediately contact Multiquip technical support at 800-478-1244 for further assistance.

WARNING!

DO NOT ATTEMPT TO REPAIR THE MACHINE IF THE FRAME SHOWS SIGNS OF SEVERE SAG OR IS BEGINNING TO SEPARATE. CONTACT MULTIQUIP TECHNICAL SUPPORT AT 800-478-1244 FOR ASSISTANCE!

WELD RECOMMENDATIONS

Current and voltage settings will vary according to the machine and operator.

Stick Weld Application

Use 7018 stick with a diameter of .125 inch. Welds should be run upward (VERTICAL) and flat (HORIZONTAL). Current should range from 90 to 120 amps.

MIG/Wire Feed Weld Application

Use only .035 or .045 inch diameter hard wire or flux core wire. Welds should be run downward (vertical) and flat (horizontal). Current should range from 22 to 26 amps with a wire feed rate of 400-450 inches/minute (IPM).

Inspect indicated areas for (reference Figure 2) visible weld failures such as cracks or fractures. Carefully inspect areas where the angle iron meets the mast stanchion tube and area around the hitch tube.

CAUTION!

Disconnect the battery located in the light tower cabinet before welding!

CAUTION!

Protect light tower cabinet with a weld blanket or suitable material!

Procedure A —Reinforcing frames that DO NOT exhibit weld fatigue. See Figure 5

1. Remove all the paint in the affected area with an angle grinder. Clean the work surface of any remaining debris or paint to prevent porosity. Weld will be applied both **OUTSIDE** and **INSIDE** the angle.
2. The initial weld bead (*see weld recommendations*) should fill the **OUTSIDE** gap over the original weld materials. This will be your *first pass*. Note: The angle material has a thickness of 3/16" and the outrigger tube material has a thickness of ¼".
3. Allow the material to cool for approximately 10 minutes before further welding. **DO NOT POUR WATER OVER THE WELD TO SPEED THE COOLING PROCESS! THIS WILL RESULT IN WELD FRACTURE!** After allowing the weld to cool use a wire brush to remove any slag from the surface.
4. Apply another weld bead on one side of the previous weld. The pass should cover half of the previous weld and half of the apparent material. This will be your *second pass*. Combined with the original factory weld this will provide three weld passes on the **OUTSIDE** of the angle.
5. Repeat **Step 4**.
6. Apply a single pass on the **INSIDE** of the angle. Be certain the bead wraps around the bottom edge of the angle. This will be the *final pass*.
7. Use a wire brush to prepare the area for paint. Once the weld has cooled apply a coat of primer and allow it to dry. Use black paint for the final finish.
8. Repeat above processes for each affected area.

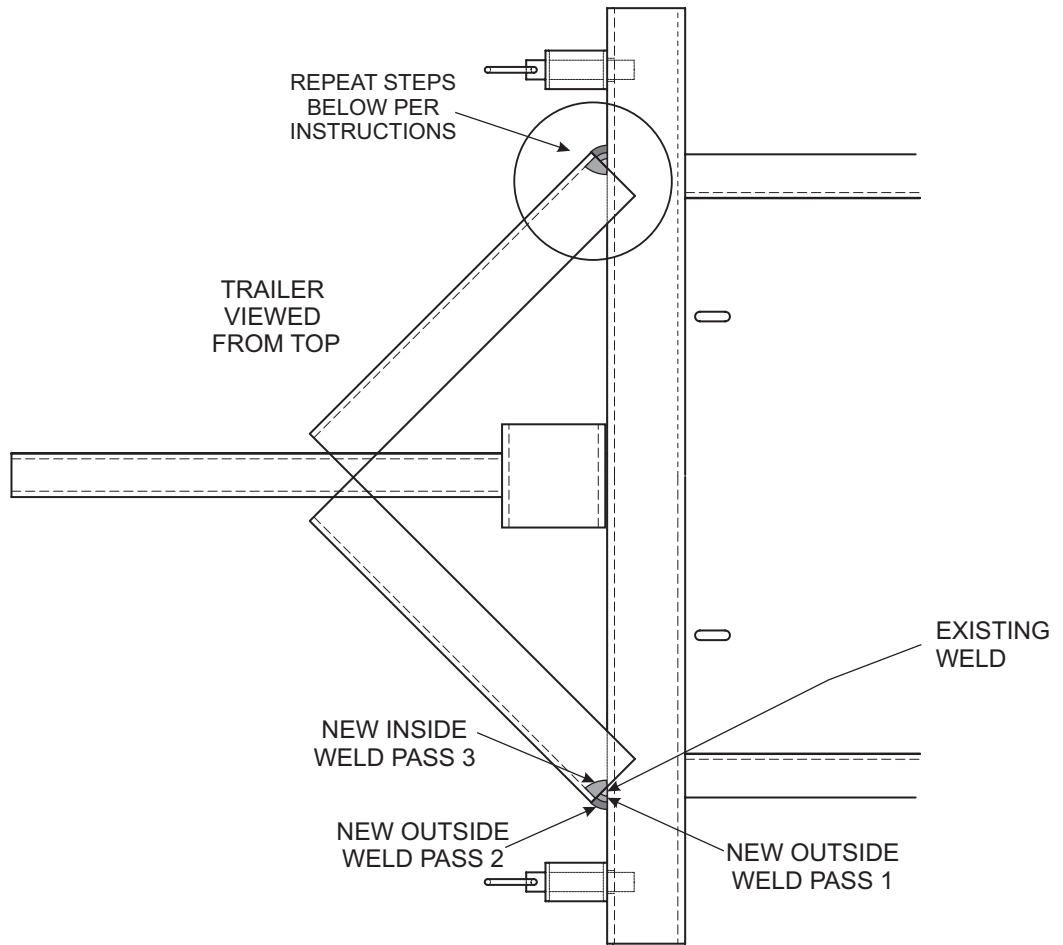

Figure 5. Reinforcing Frames (Procedure A)

WARNING!

DO NOT ATTEMPT TO REPAIR THE MACHINE IF THE FRAME SHOWS SIGNS OF SEVERE SAG OR IS BEGINNING TO SEPARATE. CONTACT THE MULTIQUIP TECHNICAL SUPPORT AT 800-478-1244 FOR ASSISTANCE!

CAUTION!

Disconnect the battery located in the light tower cabinet before welding!

CAUTION!

Protect light tower cabinet with a weld blanket or suitable material!

Procedure B – Repairing a frame that DOES exhibit weld fatigue. See Figure 6.

1. If there are indications of weld failure, such as cracks or fractures in the joint, the existing weld material will need to be removed with an angle grinder. **DO NOT WELD OVER A CRACKED OR FRACTURED WELD!**
2. Remove the existing weld material and the paint in the affected area with an angle grinder. Clean the work surface of any remaining debris or paint to prevent porosity. Weld will be applied both **OUTSIDE** and **INSIDE** the angle.
3. The initial weld bead (*see weld recommendations*) should fill the **OUTSIDE** gap between the two apparent materials. This will be your *first pass*. The angle material has a thickness of 3/16" and the outrigger tube material has a thickness of 1/4".
4. Allow the material to cool for approximately 10 minutes before further welding. **DO NOT POUR WATER OVER THE WELD TO SPEED THE COOLING PROCESS! THIS WILL RESULT IN WELD FRACTURE!** After allowing the weld to cool use a wire brush to remove any slag from the surface.
5. Apply another weld bead on one side of the previous weld. The pass should cover half of the previous weld and half of the apparent material. This will be your *second pass*.
6. Repeat **Step 4**.
7. Apply another weld bead on one side of the previous weld. The pass should cover half of the previous weld and half of the apparent material. This will be your *third OUTSIDE pass*.

8. Repeat **Step 4**.
9. Apply a final pass on the **INSIDE** of the angle. Be certain the bead wraps around the bottom edge of the angle. This will be the *final pass*.
10. Use a wire brush to prepare the area for paint. Once the weld has cooled apply a coat of primer and allow it to dry. Use black paint for the final finish.
11. Repeat process for each affected areas.

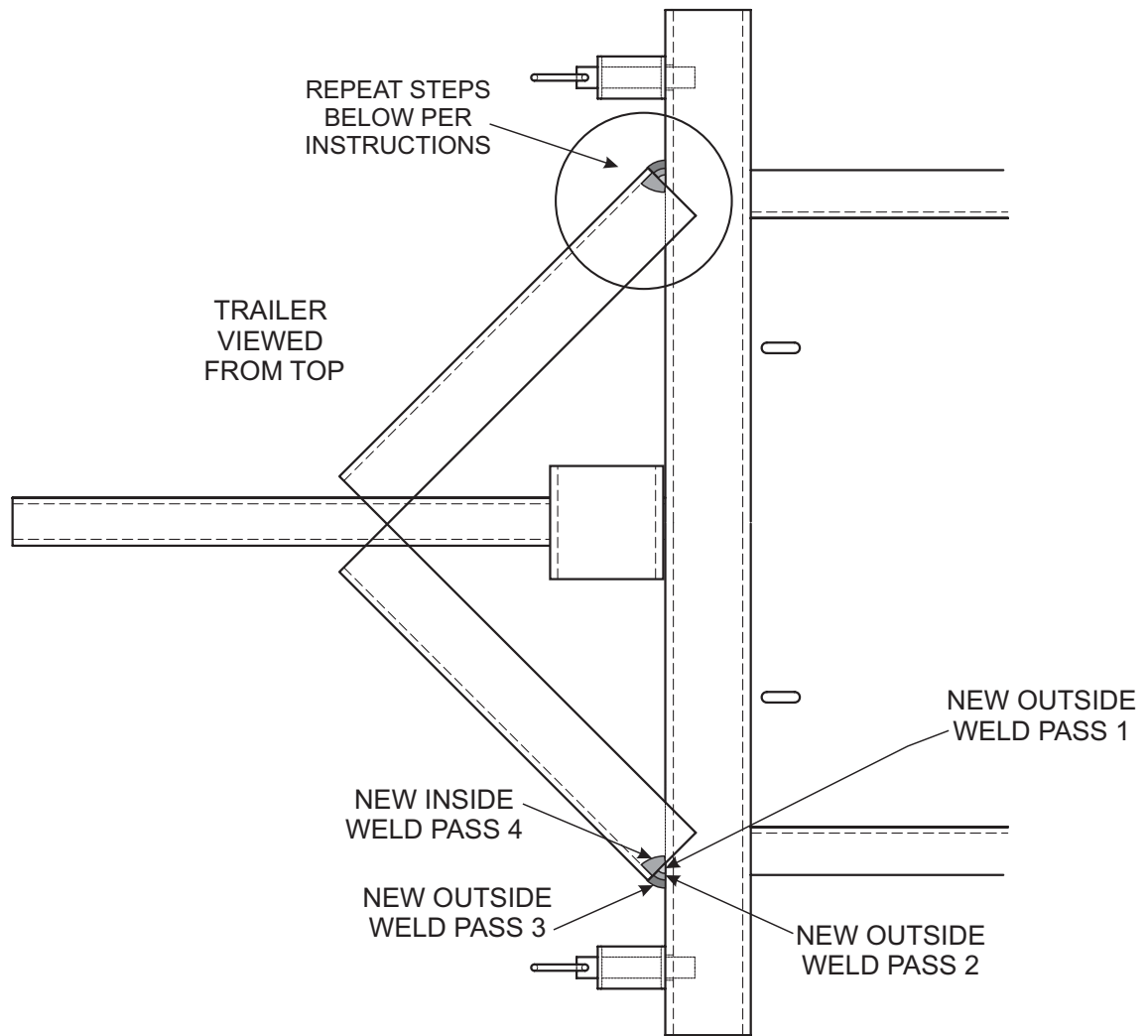

Figure 6. Repairing Frame with Weld Fatigue (Procedure B)

If you have any questions regarding either of the procedures described above contact the Multiquip technical support department at 800-478-1244 for assistance!

WARRANTY INFORMATION

Campaign: Reference No. 20070720

Multiquip will reimburse up to 1.5 hours of labor per machine for this repair.

Contact the Multiquip warranty department for claim number and warranty form.

Multiquip Warranty Department

800-421-1244

Chris Fairchild – Extension 279

Connie Ferrer – Extension 289

Wendy Sanchez - Extension 322