

# OPERATION AND PARTS MANUAL



## **MODEL MB25HD REBAR BENDER (PORTABLE ELECTRIC)**

Revision #0 (04/05/10)

To find the latest revision of this  
publication, visit our website at:  
[www.multiquip.com](http://www.multiquip.com)



**THIS MANUAL MUST ACCOMPANY THE EQUIPMENT AT ALL TIMES.**

# TABLE OF CONTENTS

---

## MB25HD REBAR BENDER

Table of Contents.....	2
Parts Ordering Procedures.....	3
Safety .....	4
Rules and Regulations .....	5-6
Specifications .....	7
General Information.....	8
Components .....	9
Operation.....	10-11
Maintenance.....	12-13
Explanation of Codes in Remarks Column.....	14
Suggested Spare Parts .....	15

## COMPONENT DRAWINGS

Case Assembly.....	16-19
Housing Assembly .....	20-25
Tool Box and Tools Assembly .....	26-27
Wiring Diagram.....	28
Terms and Conditions Of Sale — Parts.....	29

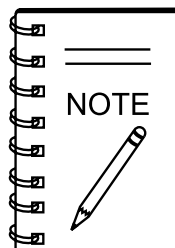

***Specification and part number are subject to change without notice.***

# PARTS ORDERING PROCEDURES

## Ordering parts has never been easier! Choose from three easy options:

Effective:  
January 1<sup>st</sup>, 2006



### Order via Internet (Dealers Only):

Order parts on-line using Multiquip's SmartEquip website!

- View Parts Diagrams
- Order Parts
- Print Specification Information



If you have an MQ Account, to obtain a Username and Password, E-mail us at: [parts@multiquip.com](mailto:parts@multiquip.com).

To obtain an MQ Account, contact your District Sales Manager for more information.

Goto [www.multiquip.com](http://www.multiquip.com) and click on **Order Parts** to log in and save!

Use the **internet** and qualify for a **5% Discount** on *Standard orders* for all orders which include complete part numbers.\*

Note: Discounts Are Subject To Change



### Order via Fax (Dealers Only):

All customers are welcome to order parts via Fax.

**Domestic (US) Customers dial:**

1-800-6-PARTS-7 (800-672-7877)

**Fax** your order in and qualify for a **2% Discount** on *Standard orders* for all orders which include complete part numbers.\*

Note: Discounts Are Subject To Change



**Order via Phone: Domestic (US) Dealers Call:**  
1-800-427-1244

### Non-Dealer Customers:

Contact your local Multiquip Dealer for parts or call 800-427-1244 for help in locating a dealer near you.



**International Customers** should contact their local Multiquip Representatives for Parts Ordering information.

## When ordering parts, please supply:

- |   |  |
|---|--|
| <input type="checkbox"/> Dealer Account Number                                | <input type="checkbox"/> Specify Preferred Method of Shipment:                         |
| <input type="checkbox"/> Dealer Name and Address                              | <input checked="" type="checkbox"/> UPS/Fed Ex <input checked="" type="checkbox"/> DHL |
| <input type="checkbox"/> Shipping Address (if different than billing address) | <input type="checkbox"/> Priority One <input checked="" type="checkbox"/> Truck        |
| <input type="checkbox"/> Return Fax Number                                    | <input type="checkbox"/> Ground  |
| <input type="checkbox"/> Applicable Model Number                              | <input type="checkbox"/> Next Day  |
| <input type="checkbox"/> Quantity, Part Number and Description of Each Part   | <input type="checkbox"/> Second/Third Day  |

### NOTICE

All orders are treated as *Standard Orders* and will ship the same day if received prior to 3PM PST.

WE ACCEPT ALL MAJOR CREDIT CARDS!



www.multiquip.com



## FOR YOUR SAFETY AND SAFETY OF OTHERS!

Safety precautions should be followed at all times when operating this equipment. Failure to read and understand the Safety Messages and Operating Instructions could result in injury to yourself and others.

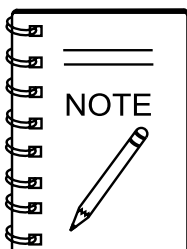

This manual has been developed to provide complete instructions for the safe and efficient operation of this equipment.

Before using this equipment ensure that the operating individual has read and understood all instructions in this manual.

## SAFETY MESSAGE ALERT SYMBOLS

The three Safety Messages shown below will inform you about potential hazards that could injure you or others. The Safety Messages specifically address the level of exposure to the operator, and are preceded by one of three words: **DANGER**, **WARNING**, or **CAUTION**.

### **DANGER**

You **WILL** be **KILLED** or **SERIOUSLY INJURED** if you **DO NOT** follow these directions.

### **WARNING**

You **CAN** be **KILLED** or **SERIOUSLY INJURED** if you **DO NOT** follow these directions.

### **CAUTION**

You **CAN** be **INJURED** if you **DO NOT** follow these directions.

## HAZARD SYMBOLS

Potential hazards associated with the operation of this equipment will be referenced with Hazard Symbols which appear throughout this manual, and will be referenced in conjunction with Safety Message Alert Symbols.

### **WARNING — Respiratory Hazards**



**ALWAYS** wear approved respiratory protection when required.

### **CAUTION — Rotating Parts Hazards**



**NEVER** operate equipment with covers or guards removed. Keep fingers, hands, hair and clothing away from all moving parts to prevent injury.

### **CAUTION — Accidental Starting Hazards**



**ALWAYS** place the equipment ON/OFF switch in the OFF position when the equipment is not in use.

### **CAUTION — Eye and Hearing Hazards**

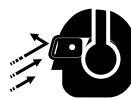

**ALWAYS** wear approved eye and hearing protection.

### **CAUTION — Equipment Damage Hazards**

Other important messages are provided throughout this manual to help prevent damage to your equipment, other property, or the surrounding environment.

# RULES AND REGULATIONS

## **WARNING — Read This Manual**

Failure to follow instructions in this manual may lead to serious injury or even **DEATH!** This equipment is to be operated by trained and qualified personnel only! This equipment is for industrial use only.

### GENERAL SAFETY

- **DO NOT** operate or service this equipment before reading this entire manual.
- This equipment should not be operated by persons under 18 years of age.
- **NEVER** operate this equipment without proper protective clothing, shatterproof glasses, steel-toed boots and other protective devices required by the job.



- **NEVER** operate this equipment when not feeling well due to fatigue, illness or when under medication.
- **NEVER** operate this equipment under the influence of drugs or alcohol.



- **NEVER** use accessories or attachments that are not recommended by Multiquip for this equipment. Damage to the equipment and/or injury to user may result.
- Manufacturer does not assume responsibility for any accident due to equipment modifications. Unauthorized equipment modification will void all warranties.
- Whenever necessary, replace nameplate, operation and safety decals when they become difficult to read.
- **ALWAYS** check the equipment for loosened threads or bolts before starting.
- **MAINTAIN** equipment is a safe operating condition at all times.
- **KEEP** bystanders, children, and visitors away while operating the equipment. Distractions can cause loss of control.

- **DO NOT** wear loose clothing or jewelry. Contain long hair. Keep hair, clothing, and gloves away from moving parts. Rotating parts can cause injury if contacted.
- **ALWAYS** keep work area clean and free of foreign matter and debris. Also keep work area well lit.
- **NEVER** operate the equipment in an explosive atmosphere or near combustible materials. An explosion or fire could result causing severe **bodily harm or even death.**
- **DO NOT** overreach. Keep proper footing and balance at all times.
- **NEVER** leave the equipment unattended. When not in use, before servicing, and when changing accessories, always unplug the equipment from the power source.
- **USE** this equipment for its intended purpose only.
- **KEEP** equipment clean for better and safer performance. Keep handles dry, clean, and free from oil and grease.
- **INSPECT** the equipment after each use. Replace any damaged or worn parts immediately. Do not use equipment if defective.
- If a malfunction occurs, immediately unplug the equipment from the power source and correct the problem. If problem cannot be corrected, contact the nearest MQ service center.
- **ALWAYS** store the equipment in a clean, dry location out of the reach of children.



### EMERGENCIES

- **ALWAYS** know the location of the nearest **fire extinguisher.**
- **ALWAYS** know the location of the nearest **first aid kit.**
- In emergencies, **always** know the location of the nearest phone or **keep a phone on the job site.** Also know the phone numbers of the nearest **ambulance, doctor** and **fire department.** This information will be invaluable in case of emergency.



# RULES AND REGULATIONS







## ELECTRICAL SAFETY

- **ALWAYS** test the **POWER** switch on the equipment before operating. The purpose of this switch is to shut down the power.
- **NEVER** use an extension cord that is frayed or damaged where the insulation has been cut.
- **NEVER** carry the equipment by its power cord or disconnect it by yanking the cord from the power outlet.
- **ALWAYS** make certain that the proper extension cord has been selected for the job. See Extension Cord Gauge Selection Table.
- **NEVER** allow power cord to *lay in water*.
- **NEVER stand in water** while operating the equipment.
- When connecting the unit to a power receptacle, make sure the receptacle circuit is connected to either a GFCI receptacle or a receptacle protected by a 20 amp circuit breaker.
- When plugging the unit into a power receptacle, check the nameplate for the correct operating voltage. Operating the rebar bender at the wrong voltage will damage the electrical components. **ALWAYS** read the nameplate before applying power.
- This unit is equipped with a 3-prong male power plug. **DO NOT** use a 2-prong adapter when plugging into a wall outlet. This will defeat the purpose of the ground circuit. If the plug does not fit into the receptacle, contact a qualified electrician to install a 3-conductor wall receptacle (outlet).
- Avoid body contact with grounded surfaces such as pipes, radiators, ranges and refrigerators. There is an increased risk of electrical shock if your body is grounded.
- **DO NOT** expose the hydraulic power unit to rain or wet conditions. Water entering the power unit will increase the risk of electrical shock.
- When operating the unit outdoors, be sure to use the appropriate outdoor extension cord. This type of extension cord reduces the risk of electrical shock.
- **ALWAYS** remove the AC power cord from the power source before performing any service or maintenance on the unit. This preventative safety measure reduces the possibility of accidental starting.
- When operating near an arc welder, it is important that both the unit and the welding equipment be connected to the same earth ground. If they are not, severe damage to the unit, particularly to the power cord could occur. Personal injury may also occur.

Extension Cord Gauge Selection										
Ampere Rating Range	Volts	Length of Cord in Feet								
	115V	25 Ft.	50 Ft.	100 Ft.	150 Ft.	200 Ft.	250 Ft.	300 Ft.	400 Ft.	500 Ft.
	230V	50 Ft.	100 Ft.	200 Ft.	300 Ft.	400 Ft.	500 Ft.	600 Ft.	800 Ft.	1000 Ft.
0 - 2		18	18	18	16	16	14	14	12	12
2 - 3		18	18	16	14	14	12	12	10	10
3 - 4		18	18	16	14	12	12	10	10	8
4 - 5		18	18	14	12	12	10	10	8	8
5 - 6		18	16	14	12	10	10	8	8	6
6 - 8		18	16	12	10	10	8	6	6	6
8 - 10		18	14	12	10	8	8	6	6	4
10 - 12		16	14	10	8	8	6	6	4	4
12 - 14		16	12	10	8	6	6	6	4	2
14 - 16		16	12	10	8	6	6	4	4	2
16 - 18		14	12	8	8	6	4	4	2	2
18 - 20		14	12	8	6	6	4	4	2	2

# SPECIFICATIONS

TABLE 1. SPECIFICATIONS		
Model	MB25HD	
Capacity	Ø6(1/4") - Ø25(1"), No.2 - No.8	
Range of Bends	0° - 180°	
Motor	Single Phase, 115 V, 60 Hz, 15A	
Standard Equipment	Roller - 3	Allen Wrench - 2
	Collar - 5	Open-End Wrench - 1
	Waterproof Cover - 1	Screwdriver - 1
	Tool Box - 1	Foot Switch - 1

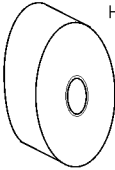
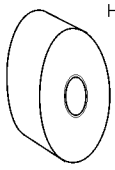
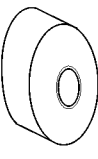
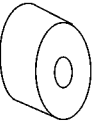
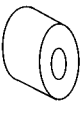
TABLE 2. SIZE OF ROLLERS AND COLLARS						
REBAR DIAMETER	No. 8 1-inch (25.4mm)	No. 7 7/8-inch (22.2mm)	No. 6 3/4-inch (19.0mm)	No. 5 5/8-inch (15.9mm)	No. 4 1/2-inch (12.7mm)	No. 3 3/8-inch (9.52mm)
ROLLER DIAMETER	 H25 DIA. 2.00" (51 MM)	 H22 DIA. 2.82" (72. MM)/OPTION	 H19 DIA. 3.62" (92.0 MM)	 H16 DIA. 5.43" (138 MM)	 H13 DIA. 6.00" (154 MM)/OPTION	 H10 DIA. 6.62" (168 MM)/OPTION
COLLAR DIAMETER	 H25 DIA. 4.92" (125 MM)	 H22 DIA. 4.32" (110 MM)	 H19 DIA. 3.73" (95 MM)	 H16 DIA. 2.20" (56 MM)	 H13 DIA. 1.81" (46 MM)	

**NOTE:** Roller NO. H25 and Collar No. H25 are factory installed on the bender.

## GENERAL INFORMATION

The **MQ MB25HD Rebar Bender** is designed to be used as a portable on-site rebar bender, capable of bending in-place rebar to approved American Concrete Institute (ACI) radius. Labor time and injuries are greatly reduced from manually bending rebar. The MB25HD is capable of bends up to 180°.

The MB25HD comes standard with 3 rollers and 5 collars which can be used in different combinations to match the diameter of the rebar to be bent.

The MB25HD comes with a foot switch which can start the bending procedure with a push of the pedal instead of pressing the start button.

An emergency button is available to immediately stop the machine when something goes wrong during bending. The roller then returns to the starting position.



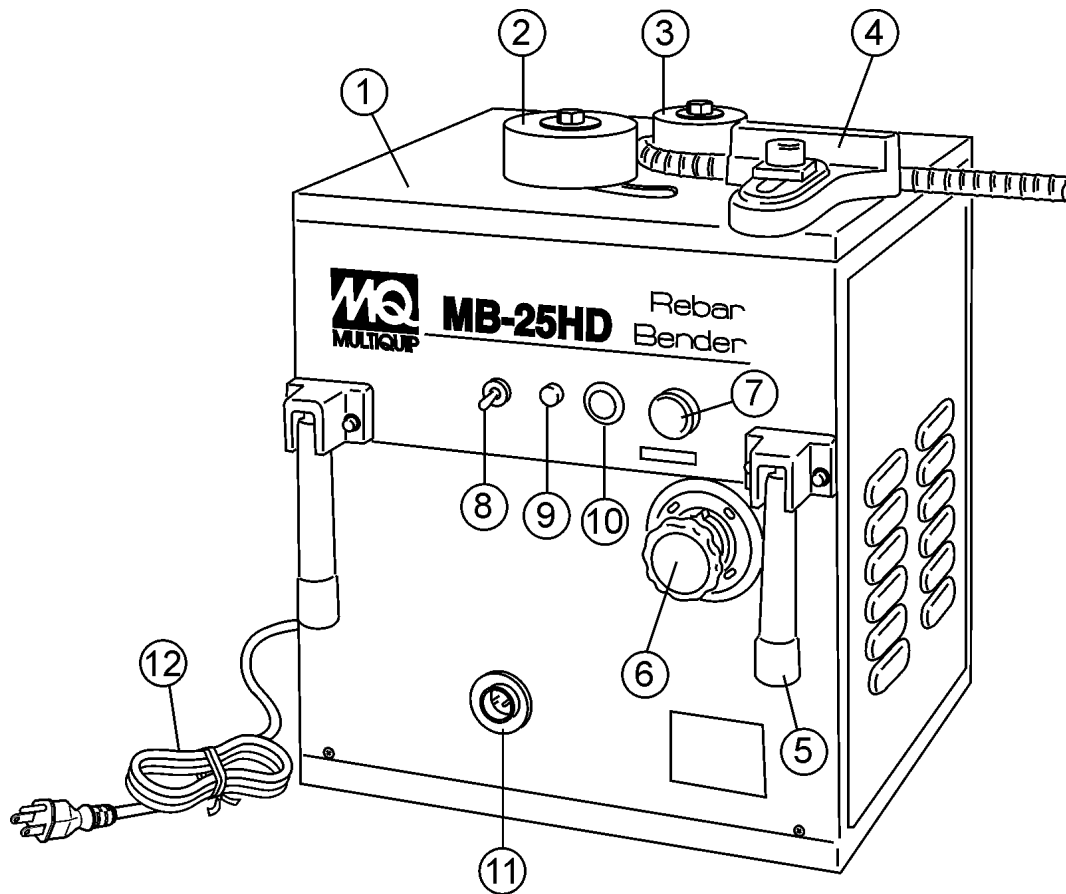

**Figure 1. MB25HD Components**

Figure 1 shows the components of the MB25HD Rebar Bender. These components are described below.

1. **Table** — Holds the roller, collar, stopper and the rebar to be bended.
2. **Roller** — Works in combination with the collar depending on the diameter of the rebar to bend.
3. **Collar** — Works in combination with the roller depending on the diameter of the rebar to bend.
4. **Stopper** — Holds the rebar in place when bending.
5. **Handle** — Used to lift the rebar bender.
6. **Angle Select Dial** — Sets the angle that the rebar is going to be bent.
7. **Emergency Stop Switch** — Stops the rebar bending and moves the roller back to the starting position.
8. **Power Switch** — Turns the power of the rebar bender on or off.
9. **Pilot Lamp** — Indicates rebar unit is on.
10. **Start Switch** — Starts the bending process.
11. **Connector (for foot switch)** — Connects to the foot switch to start the machine with a push of the pedal.
12. **Power Cord** — Connect to a 120V, 60 Hz receptacle.

## SELECTION AND INSTALLATION OF ROLLER AND COLLAR

### **WARNING**

Keep fingers from the bending area. Moving parts can cause serious injury.

Do not drop anything into the machine from the bending area as this may damage the machine.

1. Select the roller and corresponding collar to match the diameter of the rebar to be bent. See Table 2 for the different combinations.
2. Apply multi-purpose grease to the roller.
3. Install the collar and the roller as shown in Figure 2.

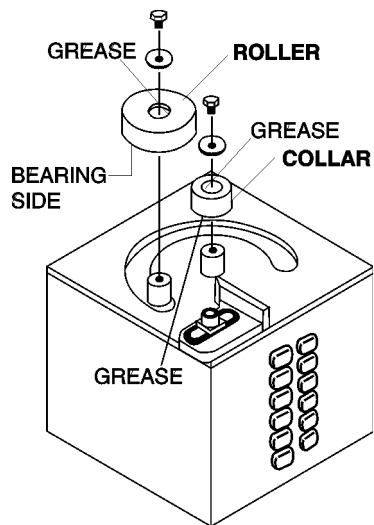

**Figure 2. Roller and Collar Installation**

4. When using a roller with a bearing, bearing must face downward.
5. When using a collar with a bearing, bearing must face downward.
6. To prevent the roller and the collar from coming off, attach the washer securely with the bolt.
7. Position the stopper so that rebar to be bent is parallel to the front of the stopper and tighten the rebar securely in place. If the rebar is not parallel to the front, the bending angle will be incorrect. See Figure 3.

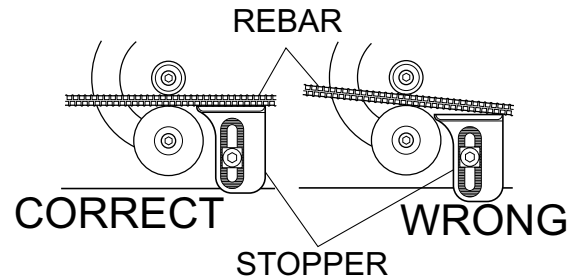

**Figure 3. Stopper Position**

8. Rotate the Angle Select Dial to the desired angle that the rebar is to be bent (Figure 4).

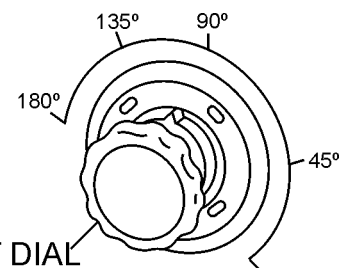
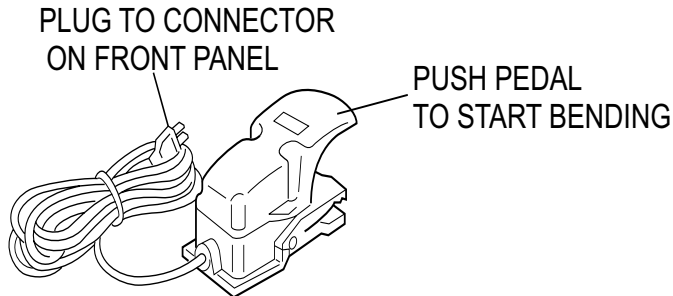

**Figure 4. Selecting the Bending Angle**

9. Plug the power cord into a proper single-phase power source. Make sure that the rebar bender is properly grounded.
10. Turn the power switch on.
11. Hold the rebar firmly and press the Start Switch. This will engage the clutch and the roller to bend the rebar.
12. After the rebar is bent to the desired angle, the roller will automatically spring back to the starting position.

## USING THE FOOT SWITCH

Instead of the Start Switch, the Foot Switch can be used to start the bending process. See Figure 5.

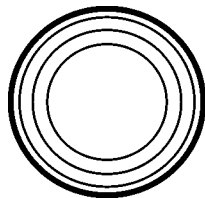

**Figure 5. Starting with the Foot Switch**

1. Insert the plug of the foot switch to the Foot Switch Connector on the front panel of the rebar bender.
2. Press the pedal on the foot switch to start bending.
3. When the bending angle is achieved, the roller will automatically spring back to the start position.

## EMERGENCY STOP SWITCH

1. To stop the rebar bender immediately in case anything goes wrong in the bending process, press the Emergency Stop Button (Figure 6). The roller on the rebar bender will immediately stop and return to the start position.



**Figure 6. Emergency Stop Switch**

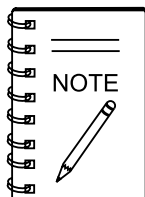

It is not necessary to press the pedal continuously while bending. Once the pedal is pressed bending will start and pedal can be released.

### **WARNING**

The roller goes back to start position very quickly after bending because of the spring mechanism. Keep away from the machine until the roller is completely back in the start position to prevent any injury.

### **DANGER**

During operation of this rebar bender, there exists the possibility of **electrocution, electrical shock or burn**, which can cause **severe bodily harm** or even **DEATH!**



To avoid these hazards:

**NEVER** use damaged or worn cables when plugging the rebar bender into an AC power receptacle.

**NEVER** grab or touch a live power cord with wet hands.

**NEVER** stand in water and touch a live power cord.

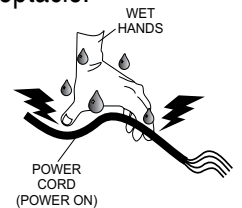

## REMOVING STEEL DEBRIS

1. To remove steel debris from the machine, tilt it and clear all debris from the outlet.

### **WARNING**

Do not let debris or rust accumulate inside the machine as this could lead to malfunction of the machine.

## REPLACING CARBON BRUSHES

### **WARNING**

Unplug unit from power source before replacing carbon brushes.

When the carbon becomes less than 5 or 6 mm (1/4 inch) the motor force deteriorates because of low rectification (Figure 7). The carbon brushes need to be replaced.

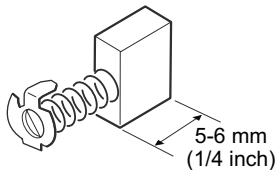

**Figure 7. Carbon Brush Size**

1. Make sure that the power plug is not connected to the power source.

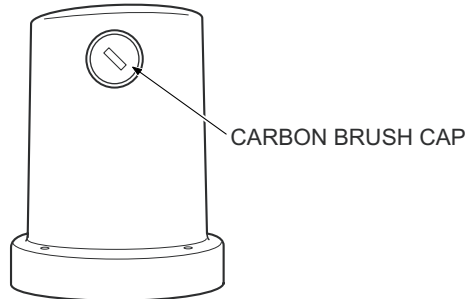

**Figure 8. Replacing Carbon Brushes**

2. Remove the rear panel and the bottom plate of the machine so that the outer frame of the motor is visible (Figure 8).
3. Remove the carbon brush cap of the motor outer frame using a standard screwdriver.
4. Replace the carbon brushes with new ones.
5. Put back the cap and reinstall the rear and end panels of the machine.

**⚠ WARNING**

Unplug unit from power source before troubleshooting.

**TABLE 4. TROUBLESHOOTING**

SYMPTOM	POSSIBLE PROBLEM	SOLUTION
Steel bar will not end because of clutch slipping.	Is clutch worn out?	Replace clutch.
	Is there an abnormal voltage drop?	Check cause of abnormal voltage drop.
	Are steel bars too hard?	Use steel bars with correct hardness.
Motor and clutch do not work while the current is on.	Are dust deposits on magnet switch contact?	Polish magnet switch.
	Is magnet switch contact worn out?	Replace magnet switch.
	Is lead wire disconnected?	Connect lead wire.
	Is electric motor weak or defective?	Replace or repair motor.
Irregularity in bending angles.	Is the stopper improperly positioned or not tightened enough?	Correct positioning and tightness of stopper.
	Is there an irregularity in the steel bar hardness?	Use steel bars with correct hardness.
Abnormal noise from motor.	Are armature cooling vanes broken or deformed?	Replace a defective armature and its bearings.
	Are armature bearings worn out?	Replace with new bearings.
	Is armature out of balance?	Replace with a new armature.
Power output motor is not sufficient.	Are carbon brushes worn out?	Replace with new ones.
	Is insulation of coils broken?	Replace armature or motor.
	Is there a drop in voltage?	Check the cause of the voltage drop.

# EXPLANATION OF CODE IN REMARKS COLUMN

The following section explains the different symbols and remarks used in the Parts section of this manual. Use the help numbers found on the back page of the manual if there are any questions.

## NOTICE

The contents and part numbers listed in the parts section are subject to change **without notice**. Multiquip does not guarantee the availability of the parts listed.

## SAMPLE PARTS LIST

NO.	PART NO.	PART NAME	QTY.	REMARKS
1	12345	BOLT.....	1	INCLUDES ITEMS W/%
2%		WASHER, 1/4 IN.....		NOT SOLD SEPARATELY
2%	12347	WASHER, 3/8 IN....	1	MQ-45T ONLY
3	12348	HOSE .....		A/R ...MAKE LOCALLY
4	12349	BEARING .....	1	S/N 2345B AND ABOVE

## NO. Column

**Unique Symbols** — All items with same unique symbol

(@, #, +, %, or >) in the number column belong to the same assembly or kit, which is indicated by a note in the “Remarks” column.

**Duplicate Item Numbers** — Duplicate numbers indicate multiple part numbers, which are in effect for the same general item, such as different size saw blade guards in use or a part that has been updated on newer versions of the same machine.

## NOTICE

When ordering a part that has more than one item number listed, check the remarks column for help in determining the proper part to order.

## PART NO. Column

**Numbers Used** — Part numbers can be indicated by a number, a blank entry, or TBD.

TBD (To Be Determined) is generally used to show a part that has not been assigned a formal part number at the time of publication.

A blank entry generally indicates that the item is not sold separately or is not sold by Multiquip. Other entries will be clarified in the “Remarks” Column.

## QTY. Column

**Numbers Used** — Item quantity can be indicated by a number, a blank entry, or A/R.

A/R (As Required) is generally used for hoses or other parts that are sold in bulk and cut to length.

A blank entry generally indicates that the item is not sold separately. Other entries will be clarified in the “Remarks” Column.

## REMARKS Column

Some of the most common notes found in the “Remarks” Column are listed below. Other additional notes needed to describe the item can also be shown.

**Assembly/Kit** — All items on the parts list with the same unique symbol will be included when this item is purchased.

Indicated by:

“INCLUDES ITEMS W/(unique symbol)”

**Serial Number Break** — Used to list an effective serial number range where a particular part is used.

Indicated by:

“S/N XXXXX AND BELOW”

“S/N XXXX AND ABOVE”

“S/N XXXX TO S/N XXX”

**Specific Model Number Use** — Indicates that the part is used only with the specific model number or model number variant listed. It can also be used to show a part is NOT used on a specific model or model number variant.

Indicated by:

“XXXXX ONLY”

“NOT USED ON XXXX”

**“Make/Obtain Locally”** — Indicates that the part can be purchased at any hardware shop or made out of available items. Examples include battery cables, shims, and certain washers and nuts.

**“Not Sold Separately”** — Indicates that an item cannot be purchased as a separate item and is either part of an assembly/kit that can be purchased, or is not available for sale through Multiquip.

## MB25HD REBAR BENDER

*1 to 3 Units*

Qty.	P/N	Description
2.....	M5CBC65D00 .....	HOLDER CAP
2.....	M5CBS65D00.....	CARBON BRUSH

# MB25HD — CASE ASSEMBLY

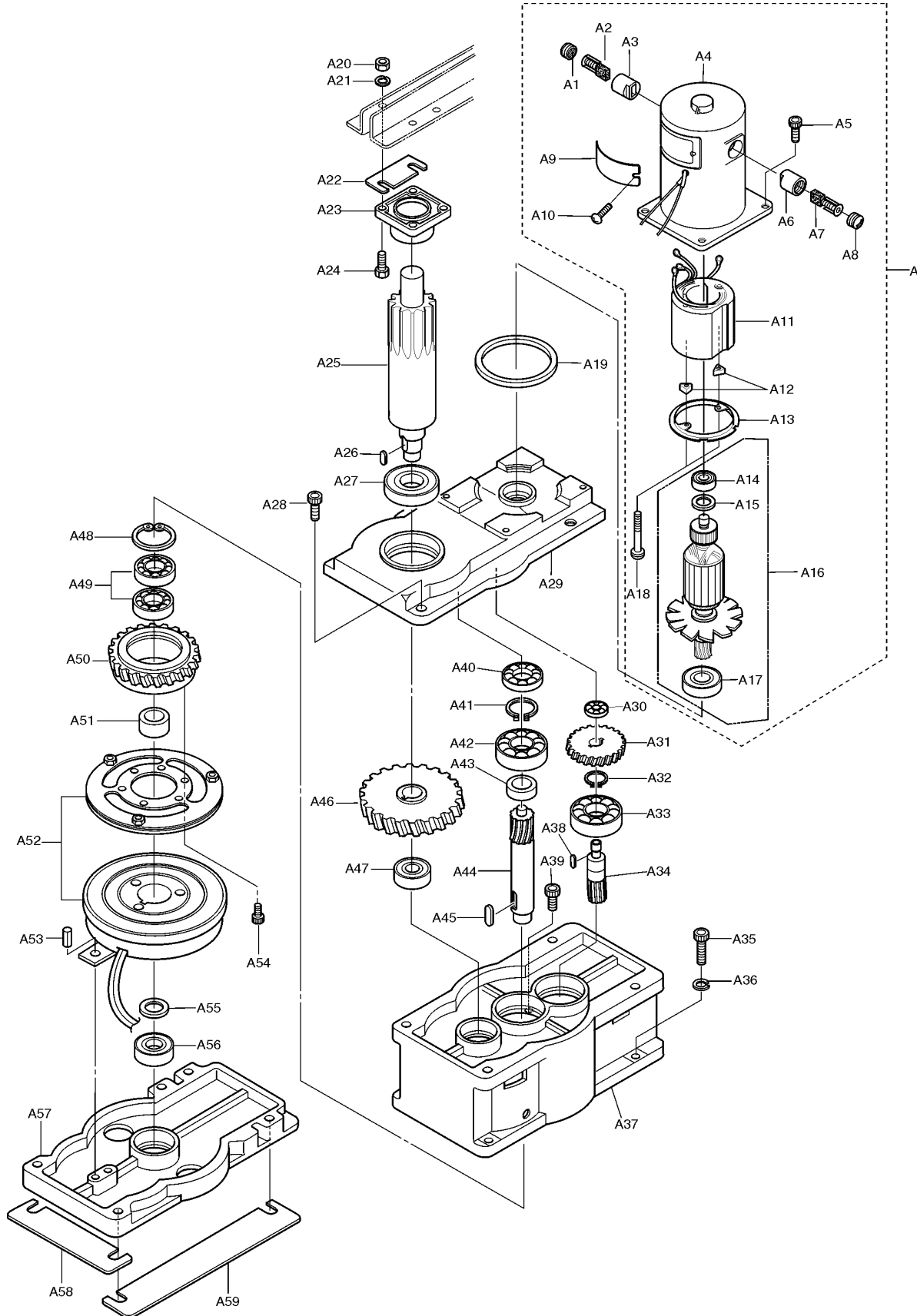



## MB25HD — CASE ASSEMBLY

<u>NO.</u>	<u>PART NO.</u>	<u>PART NAME</u>	<u>QTY.</u>	<u>REMARKS</u>
A	M5M0115V00	MOTOR ASSY., 115V .....	1	INCLUDES ITEMS W/#
A1#	M5CBC65D00	CARBON BRUSH CAP	1	
A2#	M5CBS65D00	CARBON BRUSH .....	1	INCLUDES ITEM A7 (SET)
A3#	6070020	CARBON BRUSH HOLDER	1	
A4#	M5T2059400	MOTOR CASE	1	
A5#	M5HB0520M0	BOLT HB 5X20	4	
A6#	6070020	CARBON BRUSH HOLDER	1	
A7#	M5CBS65D00	CARBON BRUSH .....	1	INCLUDES ITEM A2 (SET)
A8#	M5CBC65D00	CARBON BRUSH CAP	1	
A9#	C5T4225600	HALF OPEN COVER	1	
A10#	H9XR0410M0	BOLT XR 4X6	2	
A11#	M5STR65D00	STATOR, 115V	1	
A12#	6077110	TRIANGLE WASHER	2	
A13#	6077070	FAN GUIDE	1	
A14#%	M5B608ZZ00	BALL BEARING 608ZZNC	1	
A15#%	M5T4248200	WASHER, ARMATURE	1	
A16#	M5AM115V00	ARMATURE, 115V .....	1	INCLUDES ITEMS W/%
A17#%	M5B6201Z00	BALL BEARING 6201ZZNC	1	
A18#	M5XR051100	BOLT W/LOCK WASHER XR 5X110	4	
A19	M5T4230400	MOTOR RING	1	
A20	M5NM101M00	NUT NM10	4	
A21	M5SW1001M0	WASHER SW10	4	
A22	3300080	LINER (PILLOW BLOCK)	2	
A23	M5UCF20500	PILLOW BLOCK UCF205	1	
A24	M5SB1030M0	BOLT SB 10X35	4	
A25	3600380	SHAFT WITH GEAR	1	
A26	3701200	KEY FOR SHAFT WITH GEAR	1	
A27	M5B6006Z00	BALL BEARING 6006Z	1	
A28	C5HB0830M0	BOLT HB 8X30	4	
A29	M5T2073300	MOTOR BASE	1	
A30	H9B6080000	BALL BEARING 608	1	
A31	C5T4217900	GEAR NO.2	1	
A32	M5SNR20S00	STOP RING S20	1	
A33	M5B6204Z00	BALL BEARING 6204Z	1	
A34	M5T4329800	GEAR NO.3	1	
A35	M5HB084500	BOLT HB 8X50	4	
A36	C5SW0801M0	WASHER SW8	4	
A37	M5T2073400	GEAR CASE	1	
A38	M5K0404060	KEY FOR GEAR NO.3	1	
A39	M5HB082500	BOLT HB 8X25	1	
A40	C5B6202000	BALL BEARING 6202	1	

# MB25HD — CASE ASSEMBLY (CONTINUED)

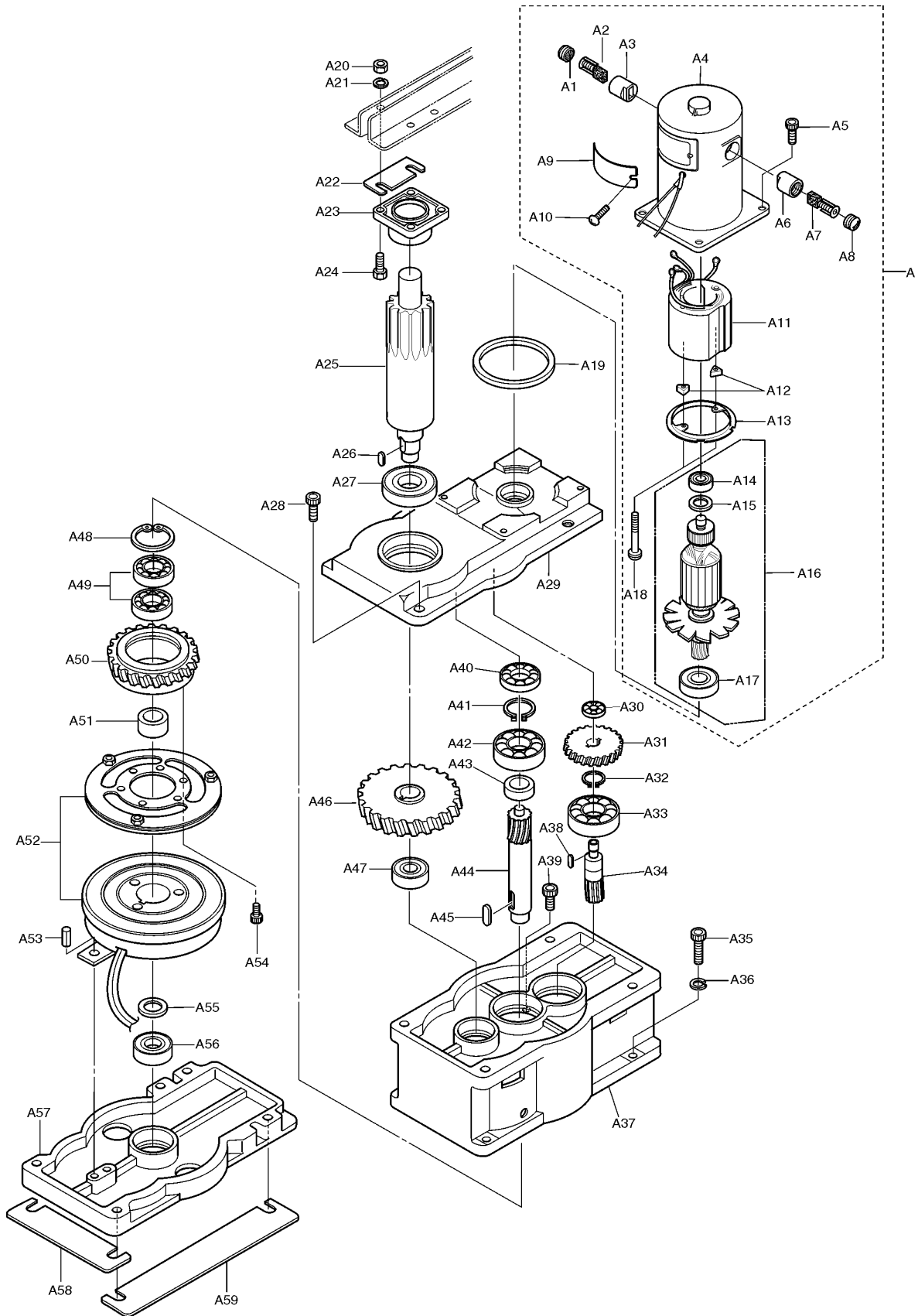

## **MB25HD — CASE ASSEMBLY (CONTINUED)**

---

<b><u>NO.</u></b>	<b><u>PART NO.</u></b>	<b><u>PART NAME</u></b>	<b><u>QTY.</u></b>	<b><u>REMARKS</u></b>
A41	7410040	STOP RING S24	1	
A42	M5B6205Z00	BALL BEARING 6205Z	1	
A43	3503500	COLLAR NO.1 FOR GEAR NO.5	1	
A44	3601890	GEAR NO.5	1	
A45	M5K0707300	KEY FOR GEAR NO.5	1	
A46	3602180	GEAR NO.6	1	
A47	M5B6004000	BALL BEARING 6004Z	1	
A48	M5SNR47H00	STOP RING H47	1	
A49	M5B6005Z00	BALL BEARING 6005Z	2	
A50	M5T4330000	GEAR NO.4	1	
A51	M5T4329600	COLLAR NO.2 (CLUTCH)	1	
A52	M5CLMMC500	MAGNET CLUTCH (MMC-5)	1	
A53	M5SRP05260	SPRING PIN SRP5530	1	
A54	7513000	BOLT HB 6X10	6	
A55	M5T4336300	LINER B	1	
A56	M5B6004000	BALL BEARING 6004Z	1	
A57	M5T2073500	GEAR CASE COVER	1	
A58	3300100	LINER S (GEAR CASE COVER)	2	
A59	3300090	LINER L (GEAR CASE COVER)	2	

# MB25HD — HOUSING ASSEMBLY

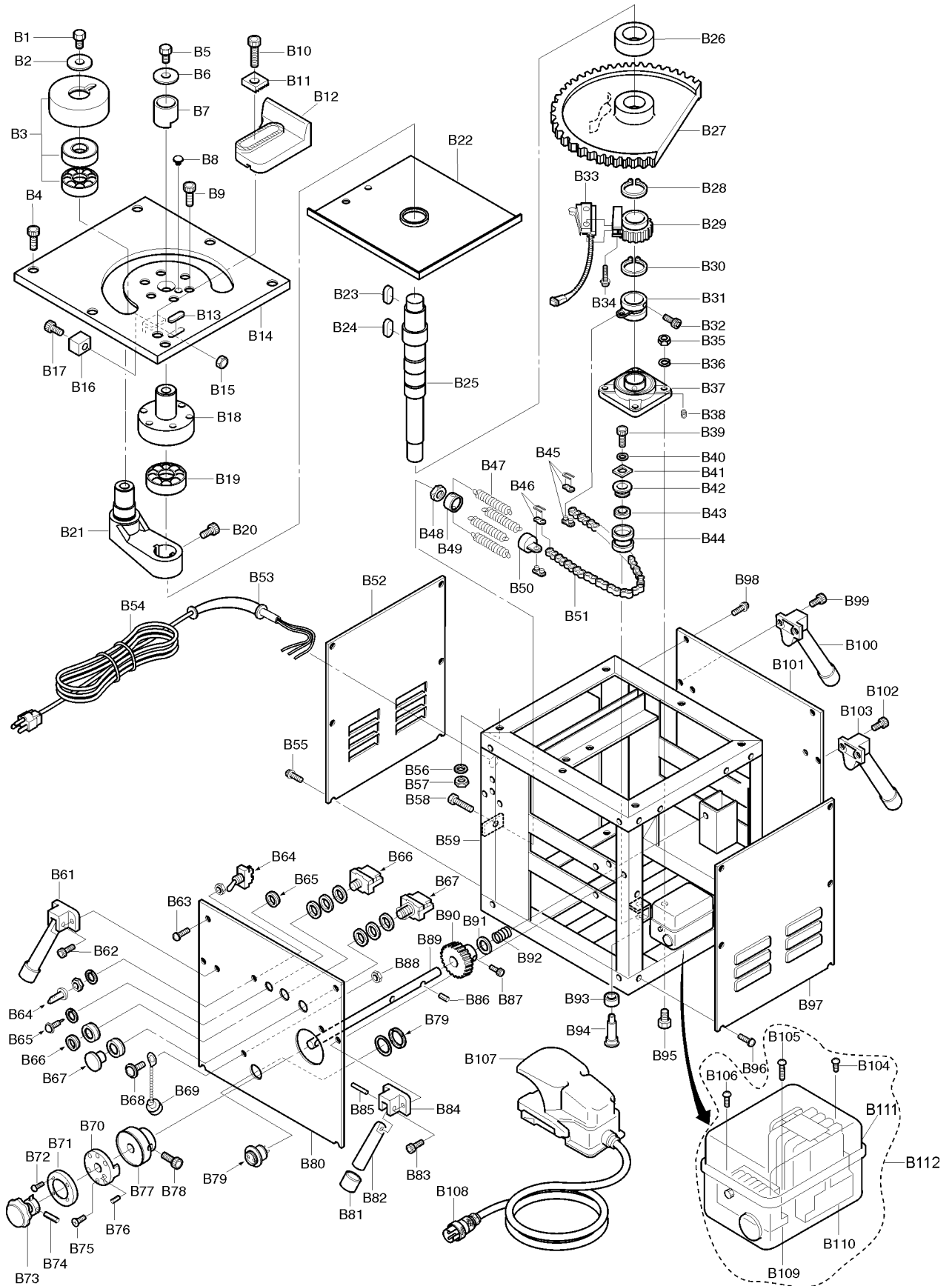

## MB25HD — HOUSING ASSEMBLY

<u>NO.</u>	<u>PART NO.</u>	<u>PART NAME</u>	<u>QTY.</u>	<u>REMARKS</u>
B1	M5SB122000	BOLT SB12520	1	
B2	M5T4273800	WASHER A	1	
B3	9000850	ROLLER NO.10 (ø168) .....	1	.....OPTION
B3	9000870	ROLLER NO.13 (ø154) .....	1	.....OPTION
B3	9000840	ROLLER NO.16 (ø138)	1	
B3	9000850	ROLLER NO.19 (ø92)	1	
B3	9000880	ROLLER NO. 22 (ø72).....	1	.....OPTION
B3	3150570	ROLLER NO. 25 (ø51)	1	
B4	014212030	BOLT, 12X30	1	
B5	012012020	BOLT, 12X20	1	
B6	M5T4273800	WASHER A	1	
B7	3505750	COLLAR NO.13 (ø46)	1	
B7	3505740	COLLAR NO.16 (ø56)	1	
B7	3505730	COLLAR NO.19 (ø95)	1	
B7	3505720	COLLAR NO.22 (ø110)	1	
B7	9000890	COLLAR NO.25 (ø125)	1	
B8	M5T4266000	PIN	1	
B9	M5HB102500	BOLT HB 10X25	6	
B10	M5HB205000	BOLT HB 20X50	1	
B11	M5T4267800	WASHER B	1	
B12	M5T42640N1	STOPPER	1	
B13	M5K1008500	KEY FOR STOPPER	1	
B14	M5T4331400	TABLE	1	
B15	M5NM080100	NUT NM8	1	
B16	M5T4269700	SHOCK ABSORBER	1	
B17	C5HB0830M0	BOLT HB8530	1	
B18	M5T4273600	ATTACH PIN	1	
B19	M5B6308Z00	BALL BEARING 6308Z	1	
B20	C5HB0830M0	BOLT HB8530	1	
B21	9000230	ARM	1	
B22	M5T4331900	DUST PLATE	1	
B23	M5K1208440	KEY FOR GEAR WHEEL	1	
B24	M5K1208440	KEY FOR GEAR WHEEL	1	
B25	M5T43289N1	OUTPUT SHAFT	1	
B26	M5T4338100	BUSHING	1	
B27	9000740	GEAR WHEEL	1	
B28	M5SNR45S00	STOP RING S45	1	
B29	M5T43308N2	SPIRAL GEAR B	1	
B30	M5SNR40S00	STOP RING S40	1	
B31	M5T44829N1	CHAIN FITTING COLLAR	1	

# MB25HD — HOUSING ASSEMBLY (CONTINUED)

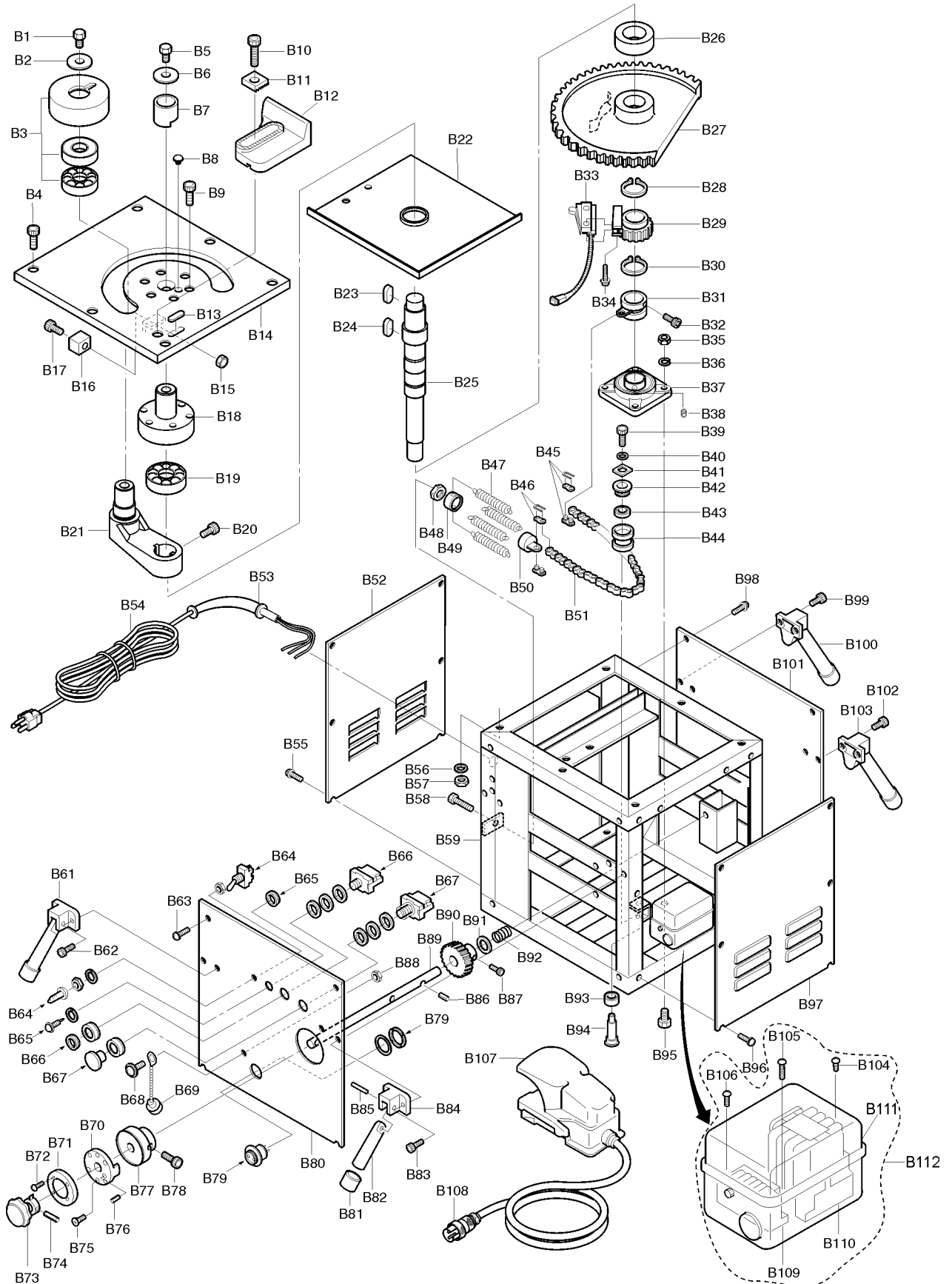

## MB25HD — HOUSING ASSEMBLY (CONTINUED)

<b>NO.</b>	<b>PART NO.</b>	<b>PART NAME</b>	<b>QTY.</b>	<b>REMARKS</b>
B32	M5HB082500	BOLT HB8525	1	
B33	M5AZ714100	LIMIT SWITCH	1	
B34	7538140	BOLT W/WASHER, LOCK XR4530	2	
B35	M5NM120100	NUT NM12-1	4	
B36	M5SW1201M0	WASHER SW12	4	
B37	M5UCF20700	PILLOW BLOCK UCF-207	1	
B38	7521000	BOLT HS858	2	
B39	7513010	BOLT HB6512	1	
B40	H9SW060100	WASHER SW6	1	
B41	7651000	PLAIN WASHER M6	1	
B42	M5T4464900	BEARING WASHER	1	
B43	7101040	BALL BEARING 6002Z	1	
B44	M5T44598N1	CHAIN ROLLER	1	
B45	6600100	JOINT LINK SET	1	
B46	6600100	JOINT LINK SET	1	
B47	M5T4484000	RETURN SPRING C	4	
B48	7700100	NUT NM12-3	1	
B49	M5T4481200	RETURN SPRING FITTING A	1	
B50	M5T4481300	RETURN SPRING FITTING B	1	
B51	M5T4484500	ROLLER CHAIN B	1	
B52	M5T4332800	PANEL B	1	
B53	H9Y8411000	RUBBER BUSHING	1	
B54	H9EC115V00	CORD WITH PLUG (UL)	1	
B55	M5XR0410M0	BOLT W/WASHER, LOCK XR4510	6	
B56	M5SW1201M0	WASHER SW12	6	
B57	M5NM120100	NUT NM12	6	
B58	M5SB127000	BOLT SB12570	1	
B59	M5T1048000	FRAME	1	
B60	8103030	TOOL BOX	1	
B61	90003000	HANDLE SET	1	
B62	C5HB0830M0	BOLT HB8530	2	
B63	M5XR0410M0	BOLT W/WASHER, LOCK XR4510	4	
B64	C5ST52K000	TOGGLE SWITCH	1	
B65	M5BN564000	PILOT LAMP	1	
B66	M518331N00	START SWITCH	1	
B67	M518920N00	EMERGENCY STOP SWITCH	1	
B68	7538000	BOLT W/WASHER, LOCK XR358	1	
B69	M5HS25RC00	FOOT SWITCH CONNECTOR CAP	1	
B70	3503600	ANGLE SELECT GUIDE A	1	
B71	M5T4334200	ANGLE DIAL PLATE	1	

# MB25HD — HOUSING ASSEMBLY (CONTINUED)

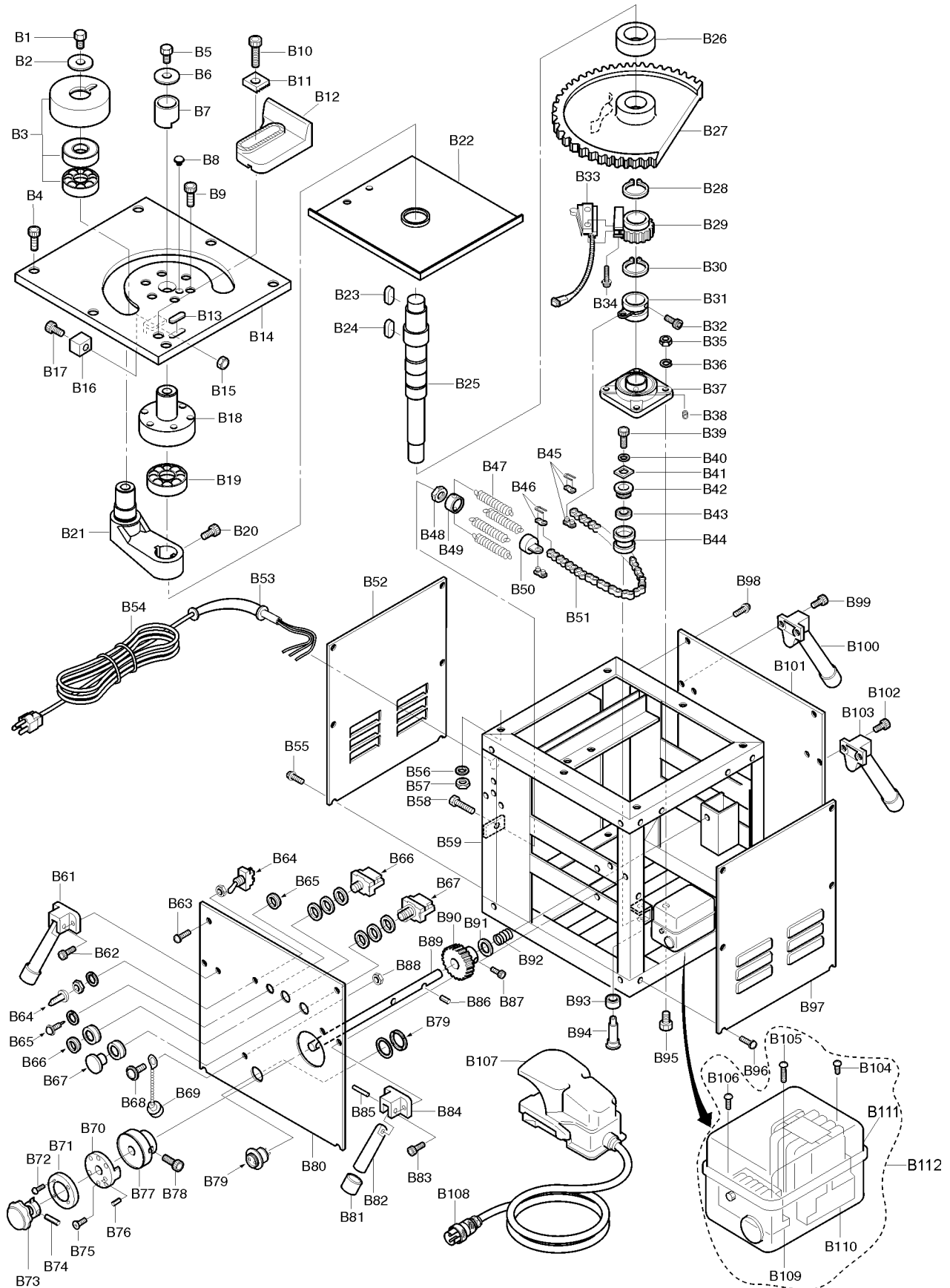



## MB25HD — HOUSING ASSEMBLY (CONTINUED)

<u>NO.</u>	<u>PART NO.</u>	<u>PART NAME</u>	<u>QTY.</u>	<u>REMARKS</u>
B72	H9XR0410M0	BOLT XR456	4	
B73	M5T4328300	ANGLE SELECT KNOB	1	
B74	MSRP054000	SPRING PIN SRP5540	1	
B75	7540020	BOLT XF 5X15	2	
B76	7810040	SPRING PIN SRP 4X16	2	
B77	3503610	ANGLE SELECT GUIDE B	1	
B78	M5HB082500	BOLT HB 8X25	1	
B79	M5SCNH3002	FOOT SWITCH CONNECTOR F	1	
B80	3302320	PANEL A	1	
B81	M5HDLCP272	RUBBER CAP (ø27.2)	1	
B82	M5T4269000	HANDLE	1	
B83	C5HB0830M0	BOLT HB 8X30	2	
B84	M5T42272N1	HANDLE BRACKET	1	
B85	M5SRP10350	SPRING PIN SRP10X36 (STAINLESS)	1	
B86	M5SRP05260	SPRING PIN SRP 5X25	1	
B87	M5HB082000	BOLT HB 8X20	1	
B88	7700020	NUT NM3	1	
B89	M5T43284N1	ANGLE SELECT BAR	1	
B90	M5T4330700	SPIRAL GEAR A	1	
B91	M5WM160100	WASHER WM16	1	
B92	M5T4328800	COIL SPRING	1	
B93	7101040	BALL BEARING 6002Z	1	
B94	M5T4459900	ROLLER SHAFT	1	
B95	M5SB123500	BOLT SB 12X35	4	
B96	M5XR0410M0	BOLT W/WASHER, LOCK XR4510	6	
B97	M5T4332800	PANEL B	1	
B98	M5XR0410M0	BOLT W/WASHER, LOCK XR4510	4	
B99	C5HB0830M0	BOLT HB 8X30	2	
B100	90003000	HANDLE SET	1	
B101	M5T4332900	PANEL C	1	
B102	C5HB0830M0	BOLT HB 8X30	2	
B103	90003000	HANDLE SET	1	
B104#	7538090	BOLT W/WASHER, LOCK XR 5X10	1	
B105#	7538160	BOLT W/WASHER, LOCK XR 5X25	1	
B106#	7538190	BOLT W/WASHER, LOCK XR 5X15	1	
B107	M5KOKUSFM1	FOOT SWITCH ASSEMBLY	1	
B108	M5SCH3002P	FOOT SWITCH CONNECTOR	1	
B109#	M5OPR10900	RECTIFIER	1	
B110#	6200410	MAGNET SWITCH	1	
B111#	M5MGSWBOX0	MAGNET SWITCH BOX	1	
B112	M5SK20ASSY	MAGNET SWITCH ASSEMBLY .....	1	INCLUDES ITEMS W/#

# MB25HD — TOOL BOX AND TOOLS ASSEMBLY

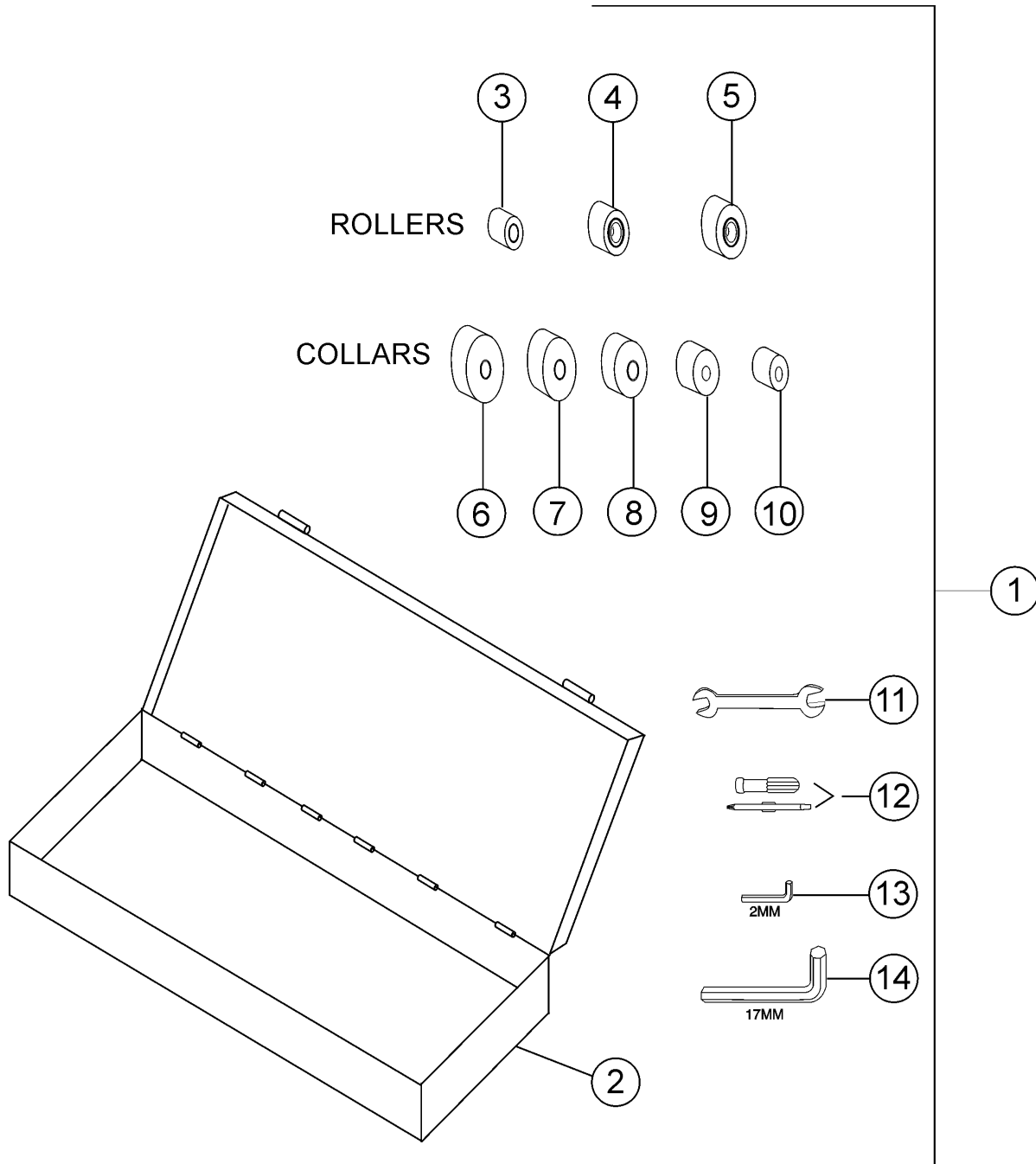

## MB25HD — TOOL BOX AND TOOLS ASSEMBLY

---

<u>NO.</u>	<u>PART NO.</u>	<u>PART NAME</u>	<u>QTY.</u>	<u>REMARKS</u>
1	9010060	TOOL BOX SET.....	1	INCLUDES ITEMS W/#
2*	8103030	TOOL BOX	1	
3	3150570	ROLLER NO. 25 (ø51)	1	
4	9000850	ROLLER NO.19 (ø92)	1	
5	9000840	ROLLER NO.16 (ø138)	1	
6	9000890	COLLAR NO.25 (ø125)	1	
7	3505720	COLLAR NO.22 (ø110)	1	
8	3505730	COLLAR NO.19 (ø95)	1	
9	3505740	COLLAR NO.16 (ø56)	1	
10	3505750	COLLAR NO.13 (ø46)	1	
11*	8201020	OPEN END WRENCH 17 X19 MM	1	
12*	8201510	SCREWDRIVER	1	
13*	8200020	ALLEN WRENCH M2	1	
14*	8200120	ALLEN WRENCH M17	1	

# MB25HD — WIRING DIAGRAM

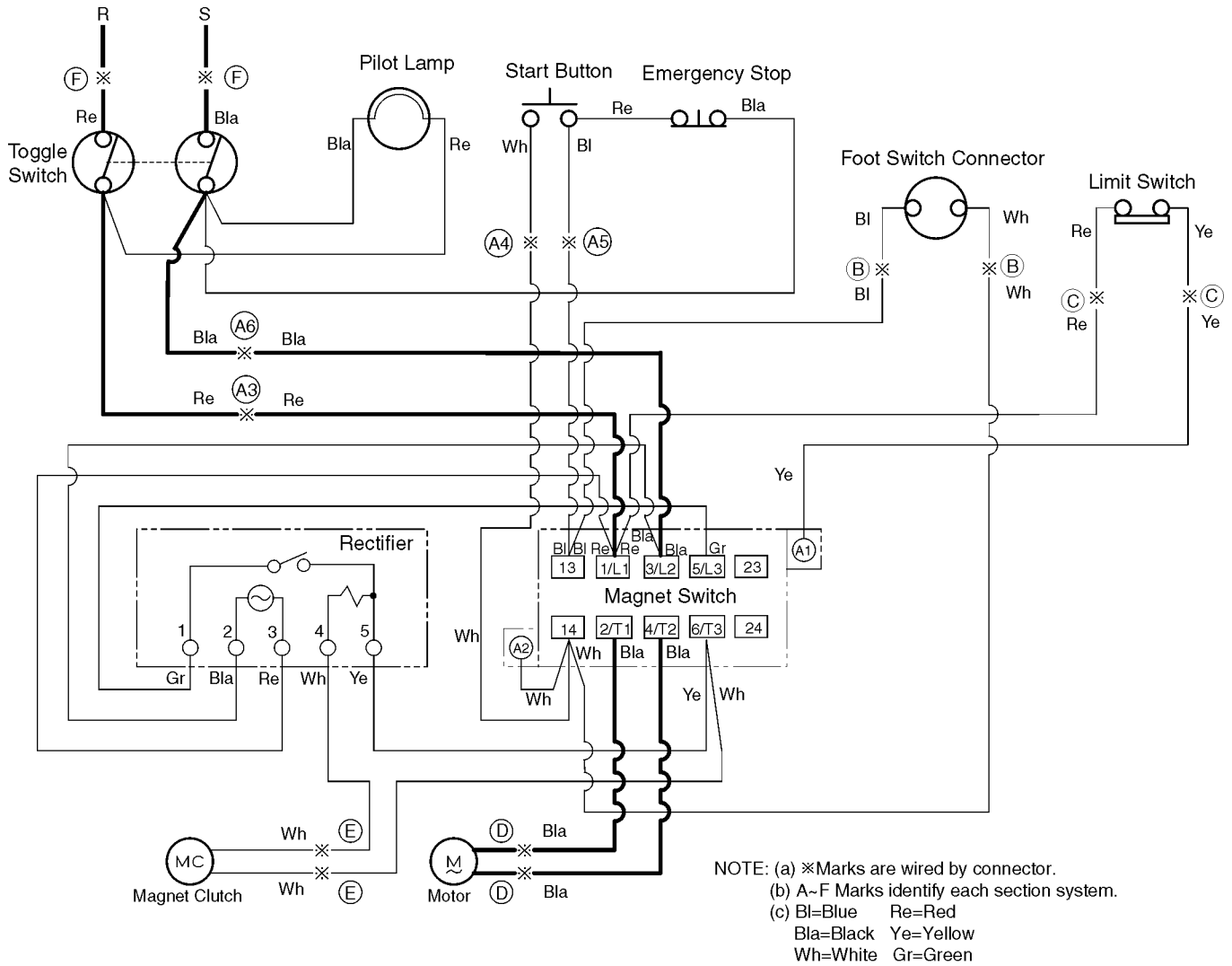

# TERMS AND CONDITIONS OF SALE — PARTS

---

## PAYMENT TERMS

Terms of payment for parts are net 30 days.

## FREIGHT POLICY

All parts orders will be shipped collect or prepaid with the charges added to the invoice. All shipments are F.O.B. point of origin. Multiquip's responsibility ceases when a signed manifest has been obtained from the carrier, and any claim for shortage or damage must be settled between the consignee and the carrier.

## MINIMUM ORDER

The minimum charge for orders from Multiquip is \$15.00 net. Customers will be asked for instructions regarding handling of orders not meeting this requirement.

## RETURNED GOODS POLICY

Return shipments will be accepted and credit will be allowed, subject to the following provisions:

1. A Returned Material Authorization must be approved by Multiquip prior to shipment.
2. To obtain a Return Material Authorization, a list must be provided to Multiquip Parts Sales that defines item numbers, quantities, and descriptions of the items to be returned.
  - a. The parts numbers and descriptions must match the current parts price list.
  - b. The list must be typed or computer generated.
  - c. The list must state the reason(s) for the return.
  - d. The list must reference the sales order(s) or invoice(s) under which the items were originally purchased.
  - e. The list must include the name and phone number of the person requesting the RMA.
3. A copy of the Return Material Authorization must accompany the return shipment.
4. Freight is at the sender's expense. All parts must be returned freight prepaid to Multiquip's designated receiving point.

5. Parts must be in new and resalable condition, in the original Multiquip package (if any), and with Multiquip part numbers clearly marked.
6. The following items are not returnable:
  - a. Obsolete parts. (If an item is in the price book and shows as being replaced by another item, it is obsolete.)
  - b. Any parts with a limited shelf life (such as gaskets, seals, "O" rings, and other rubber parts) that were purchased more than six months prior to the return date.
  - c. Any line item with an extended dealer net price of less than \$5.00.
  - d. Special order items.
  - e. Electrical components.
  - f. Paint, chemicals, and lubricants.
  - g. Decals and paper products.
  - h. Items purchased in kits.
7. The sender will be notified of any material received that is not acceptable.
8. Such material will be held for five working days from notification, pending instructions. If a reply is not received within five days, the material will be returned to the sender at his expense.
9. Credit on returned parts will be issued at dealer net price at time of the original purchase, less a 15% restocking charge.
10. In cases where an item is accepted, for which the original purchase document can not be determined, the price will be based on the list price that was effective twelve months prior to the RMA date.
11. Credit issued will be applied to future purchases only.

## PRICING AND REBATES

Prices are subject to change without prior notice. Price changes are effective on a specific date and all orders received on or after that date will be billed at the revised price. Rebates for price declines and added charges for price increases will not be made for stock on hand at the time of any price change.

Multiquip reserves the right to quote and sell direct to Government agencies, and to Original Equipment Manufacturer accounts who use our products as integral parts of their own products.

## SPECIAL EXPEDITING SERVICE

A \$35.00 surcharge will be added to the invoice for special handling including bus shipments, insured parcel post or in cases where Multiquip must personally deliver the parts to the carrier.

## LIMITATIONS OF SELLER'S LIABILITY

Multiquip shall not be liable hereunder for damages in excess of the purchase price of the item with respect to which damages are claimed, and in no event shall Multiquip be liable for loss of profit or good will or for any other special, consequential or incidental damages.

## LIMITATION OF WARRANTIES

No warranties, express or implied, are made in connection with the sale of parts or trade accessories nor as to any engine not manufactured by Multiquip. Such warranties made in connection with the sale of new, complete units are made exclusively by a statement of warranty packaged with such units, and Multiquip neither assumes nor authorizes any person to assume for it any other obligation or liability whatever in connection with the sale of its products. Apart from such written statement of warranty, there are no warranties, express, implied or statutory, which extend beyond the description of the products on the face hereof.

Effective: February 22, 2006

# OPERATION AND PARTS MANUAL

## HERE'S HOW TO GET HELP

PLEASE HAVE THE MODEL AND SERIAL  
NUMBER ON-HAND WHEN CALLING

### UNITED STATES

#### *Multiquip Corporate Office*

18910 Wilmington Ave. Tel. (800) 421-1244  
Carson, CA 90746 Fax (800) 537-3927  
Contact: mq@multiquip.com

#### *Mayco Parts*

800-306-2926 Fax: 800-672-7877  
310-537-3700 Fax: 310-637-3284

#### *Service Department*

800-421-1244 Fax: 310-537-4259  
310-537-3700

#### *MQ Parts Department*

800-427-1244 Fax: 800-672-7877  
310-537-3700 Fax: 310-637-3284

#### *Warranty Department*

800-421-1244, Ext. 279 Fax: 310-537-1173  
310-537-3700, Ext. 279

#### *Technical Assistance*

800-478-1244 Fax: 310-631-5032

### MEXICO

#### *MQ Cipsa*

Carr. Fed. Mexico-Puebla KM 126.5 Tel: (52) 222-225-9900  
Momoxpan, Cholula, Puebla 72760 Mexico Fax: (52) 222-285-0420  
Contact: pmastretta@cipsa.com.mx

### CANADA

#### *Multiquip*

4110 Industriel Boul. Tel: (450) 625-2244  
Laval, Quebec, Canada H7L 6V3 Tel: (877) 963-4411  
Contact: jmartin@multiquip.com Fax: (450) 625-8664

### UNITED KINGDOM

#### *Multiquip (UK) Limited Head Office*

Unit 2, Northpoint Industrial Estate, Tel: 0161 339 2223  
Global Lane, Fax: 0161 339 3226  
Dukinfield, Cheshire SK16 4UJ  
Contact: sales@multiquip.co.uk

© COPYRIGHT 2010, MULTIQUIP INC.

Multiquip Inc and the MQ logo are registered trademarks of Multiquip Inc. and may not be used, reproduced, or altered without written permission. All other trademarks are the property of their respective owners and used with permission.

This manual MUST accompany the equipment at all times. This manual is considered a permanent part of the equipment and should remain with the unit if resold.

The information and specifications included in this publication were in effect at the time of approval for printing. Illustrations, descriptions, references and technical data contained in this manual are for guidance only and may not be considered as binding. Multiquip Inc. reserves the right to discontinue or change specifications, design or the information published in this publication at any time without notice and without incurring any obligations.

Your Local Dealer is:

