

# OPERATION AND PARTS MANUAL



## **MODEL MC12PH CONCRETE MIXER (HONDA GX340UT2QA2/GX340UT2QAP2 GASOLINE ENGINES)**

Revision #4 (08/03/23)

To find the latest revision of this  
publication, visit our website at:  
[www.multiquip.com](http://www.multiquip.com)



THIS MANUAL MUST ACCOMPANY THE EQUIPMENT AT ALL TIMES.

# PROPOSITION 65 WARNING

---



# SILICOSIS/RESPIRATORY WARNINGS

## ⚠️ WARNING

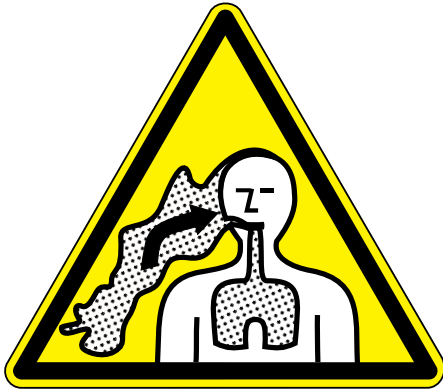

### SILICOSIS WARNING

Grinding/cutting/drilling of masonry, concrete, metal and other materials with silica in their composition may give off dust or mists containing crystalline silica. Silica is a basic component of sand, quartz, brick clay, granite and numerous other minerals and rocks. Repeated and/or substantial inhalation of airborne crystalline silica can cause serious or fatal respiratory diseases, including silicosis. In addition, California and some other authorities have listed respirable crystalline silica as a substance known to cause cancer. When cutting such materials, always follow the respiratory precautions mentioned above.

## ⚠️ WARNING

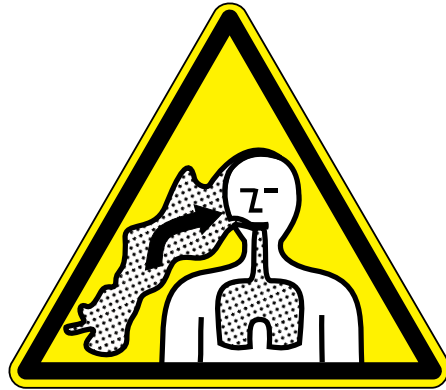

### RESPIRATORY HAZARDS

Grinding/cutting/drilling of masonry, concrete, metal and other materials can generate dust, mists and fumes containing chemicals known to cause serious or fatal injury or illness, such as respiratory disease, cancer, birth defects or other reproductive harm. If you are unfamiliar with the risks associated with the particular process and/or material being cut or the composition of the tool being used, review the material safety data sheet and/or consult your employer, the material manufacturer/supplier, governmental agencies such as OSHA and NIOSH and other sources on hazardous materials. California and some other authorities, for instance, have published lists of substances known to cause cancer, reproductive toxicity, or other harmful effects.

Control dust, mist and fumes at the source where possible. In this regard use good work practices and follow the recommendations of the manufacturers or suppliers, OSHA/NIOSH, and occupational and trade associations. Water should be used for dust suppression when wet cutting is feasible. When the hazards from inhalation of dust, mists and fumes cannot be eliminated, the operator and any bystanders should always wear a respirator approved by NIOSH/MSHA for the materials being used.

# TABLE OF CONTENTS

## MC12PH Concrete Mixer

Fuel and Chemical Exposure Warnings .....	2
Silicosis/Respiratory Warnings .....	3
Table of Contents .....	4
Training Checklist .....	5
Safety Information .....	6–11
Specifications/Dimensions .....	12
Engine Specifications .....	13
General Information .....	14
Basic Components .....	15
Engine Components .....	16
Towing Guidelines .....	17
Safety Chain Connection .....	18
Inspection .....	19–20
Start-Up .....	21
Start-Up/Operation .....	22
Operation .....	23
Maintenance (Engine) .....	24–29
Troubleshooting .....	30–31
Explanation of Code in Remarks Column .....	32
Suggested Spare Parts .....	33

## Component Drawings

Nameplate and Decals Assembly .....	34–35
Drum Assembly .....	36–37
Frame Assembly .....	38–39
Axle Assembly .....	40–41
Cabinet Assembly .....	42–43
Mounting Plate Assembly .....	44–45

## Honda GX340UT2QA2/QAP2 Gasoline Engines

Recoil Starter Assembly .....	46–47
Fan Cover Assembly .....	48–49
Carburetor Assembly .....	50–51
Air Cleaner Assembly .....	52–53
Muffler Assembly .....	54–55
Fuel Tank Assembly .....	56–57
Flywheel Assembly .....	58–59
Cylinder Head Assembly .....	60–61
Ignition Coil Assembly .....	62–63
Control Assembly .....	64–65
Cylinder Barrel Assembly .....	66–67
Crankcase Cover Assembly .....	68–69
Crankshaft Assembly .....	70–71
Piston Assembly .....	72–73
Camshaft Assembly .....	74–75
Label Assembly .....	76–77

### NOTICE

Specifications and part numbers are subject to change without notice.

# TRAINING CHECKLIST

Training Checklist			
No,	Description	OK?	Date
1	Read operation manual completely.		
2	Machine layout, location of components, checking of engine oil levels.		
3	Fuel system, refueling procedure.		
4	Operation of controls (machine not running).		
5	Safety controls, safety stop switch operation.		
6	Emergency stop procedures.		
7	Machine transport and storage.		

# SAFETY INFORMATION

Do not operate or service the equipment before reading the entire manual. Safety precautions should be followed at all times when operating this equipment. Failure to read and understand the safety messages and operating instructions could result in injury to yourself and others.



## SAFETY MESSAGES

The four safety messages shown below will inform you about potential hazards that could injure you or others. The safety messages specifically address the level of exposure to the operator and are preceded by one of four words: **DANGER**, **WARNING**, **CAUTION** or **NOTICE**.

## SAFETY SYMBOLS

**!** **DANGER**

Indicates a hazardous situation which, if not avoided, **WILL** result in **DEATH** or **SERIOUS INJURY**.

**!** **WARNING**

Indicates a hazardous situation which, if not avoided, **COULD** result in **DEATH** or **SERIOUS INJURY**.





**!** **CAUTION**

Indicates a hazardous situation which, if not avoided, **COULD** result in **MINOR** or **MODERATE INJURY**.

**NOTICE**

Addresses practices not related to personal injury.

Potential hazards associated with the operation of this equipment will be referenced with hazard symbols which may appear throughout this manual in conjunction with safety messages.

Symbol	Safety Hazard
	Lethal Exhaust Gas Hazards
	Explosive Fuel Hazards
	Burn Hazards
	Rotating Parts Hazards

# SAFETY INFORMATION

## GENERAL SAFETY

### ⚠ CAUTION

- **NEVER** operate this equipment without proper protective clothing, shatterproof glasses, respiratory protection, hearing protection, steel-toed boots and other protective devices required by the job or city and state regulations.



- Avoid wearing jewelry or loose-fitting clothes that may snag on the controls or moving parts as this can cause serious injury.
- **NEVER** operate this equipment when not feeling well due to fatigue, illness or when on medication. 
- **NEVER** operate this equipment under the influence of drugs or alcohol.



- **ALWAYS** clear the work area of any debris, tools, etc. that would constitute a hazard while the equipment is in operation.
- **ALWAYS** check the equipment for loosened threads or bolts before starting.
- **DO NOT** use the equipment for any purpose other than its intended purposes or applications.

### NOTICE

- This equipment should only be operated by trained and qualified personnel 18 years of age or older.
- Whenever necessary, replace nameplate, operation and safety decals when they become difficult to read.
- Manufacturer does not assume responsibility for any accident due to equipment modifications. Unauthorized equipment modification will void all warranties.
- **NEVER** use accessories or attachments that are not recommended by Multiquip for this equipment. Damage to the equipment and/or injury to the user may result.
- **ALWAYS** know the location of the nearest fire extinguisher. 
- **ALWAYS** know the location of the nearest first aid kit. 
- **ALWAYS** know the location of the nearest phone or **keep a phone on the job site**. Also, know the phone numbers of the nearest **ambulance, doctor and fire department**. This information will be invaluable in the case of an emergency.

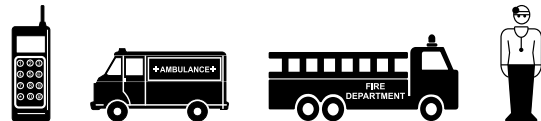

## MIXER SAFETY

### ⚠ DANGER

- **NEVER** operate the equipment in an explosive atmosphere or near combustible materials. An explosion or fire could result causing **severe bodily harm or even death**. 
- **DO NOT** mix **flammable** or **explosive** substances.

# SAFETY INFORMATION

## ⚠ WARNING

- **NEVER** place your hands inside the drum while starting or operating this equipment.
- **NEVER** disconnect any **emergency or safety devices**. These devices are intended for operator safety. Disconnection of these devices can cause **severe injury, bodily harm or even death**. Disconnection of any of these devices will void all warranties.
- Before operating the mixer, ensure that the safety grate is in position and correctly fitted.



## ⚠ CAUTION

- **NEVER** lubricate components or attempt service on a running machine.

## NOTICE

- **ALWAYS** keep the machine in proper running condition.
- **ALWAYS** ensure the mixer is on level ground before mixing.
- Fix damage to the machine and replace any broken parts immediately.
- **DO NOT** tip the mixer onto the drum mouth when the drum is rotating.
- Ensure the drum is rotating while filling and emptying the drum.
- **ALWAYS** store equipment properly when it is not being used. Equipment should be stored in a clean, dry location out of the reach of children and unauthorized personnel.
- **ALWAYS** make sure the mixer is clean of dried materials. **DO NOT** allow material to build up inside the drum. Keep the drum, frame and wheels clean. Excess debris can fall off on the highway and/or build up on the frame and wheels, creating an unbalanced condition leading to premature metal fatigue.

## ENGINE SAFETY (GASOLINE MODELS ONLY)

### ⚠ DANGER

- Engine fuel exhaust gases contain poisonous carbon monoxide. This gas is colorless and odorless, and can cause death if inhaled.
- The engine of this equipment requires an adequate free flow of cooling air. **NEVER** operate this equipment in any enclosed or narrow area where the free flow of air is restricted. If the air flow is restricted it will cause injury to people and property and serious damage to the equipment or engine.



### ⚠ WARNING

- **DO NOT** place hands or fingers inside the engine compartment when the engine is running.
- **NEVER** operate the engine with heat shields or guards removed.
- Keep fingers, hands, hair and clothing away from all moving parts to prevent injury.
- **DO NOT** remove the engine oil drain plug while the engine is hot. Hot oil will gush out of the oil tank and severely scald any persons in the general area of the mixer.



### ⚠ CAUTION

- **NEVER** touch the hot exhaust manifold, muffler or cylinder. Allow these parts to cool before servicing the equipment.
- Make certain the operator knows how to and is capable of turning the engine **OFF** in case of an emergency.



## NOTICE

- **NEVER** run the engine without an air filter or with a dirty air filter. Severe engine damage may occur. Service the air filter frequently to prevent engine malfunction.
- **NEVER** tamper with the factory settings of the engine or engine governor. Damage to the engine or equipment can result if operating in speed ranges above the maximum allowable.





# SAFETY INFORMATION

## FUEL SAFETY (GASOLINE MODELS ONLY)

### DANGER

- **DO NOT** start the engine near spilled fuel or combustible fluids. Fuel is **extremely flammable** and its vapors can cause an **explosion** if ignited.
- **ALWAYS** refuel in a well-ventilated area, away from sparks and open flames.
- **ALWAYS** use extreme caution when working with **flammable** liquids.
- **DO NOT** fill the fuel tank while the engine is running or hot.
- **DO NOT** overfill the tank, since spilled fuel can ignite if it comes into contact with hot engine parts or sparks from the ignition system.
- Store fuel in appropriate containers, in well-ventilated areas and away from sparks and flames.
- **NEVER** use fuel as a cleaning agent.
- **DO NOT** smoke around or near the equipment. **Fire or explosion** could result from fuel vapors or if fuel is spilled on a hot engine.



## GENERATOR SAFETY

If using a generator to power the mixer, refer to the applicable generator manual safety information section.



## ELECTRIC MOTOR SAFETY (ELECTRIC MODELS ONLY)

### NOTICE

- Operate the electric motor only at the specified voltage indicated on the nameplate.
- **DO NOT** spray water onto the electric motor.
- **ALWAYS** disconnect the AC power plug from the power source before moving the mixer.
- **ALWAYS** make sure the ON/OFF switch on the electric motor is in the **OFF** position when not in use and before inserting the mixer's power plug into an AC receptacle.



## Power Cord/Cable Safety

### DANGER

- **NEVER** let power cords or cables **lay in water**.
- **NEVER** use **damaged** or **worn** cables or cords when connecting the equipment to a generator. Inspect the insulation for cuts.
- **NEVER** grab or touch a live power cord or cable with wet hands. The possibility exists of **electrical shock, electrocution or death**.
- Make sure power cables are securely connected. Incorrect connections may cause electrical shock and damage to the mixer.

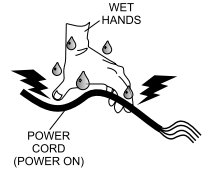

### CAUTION

- Ensure that cables and cords will not be tripped over or trapped underneath the mixer.

### NOTICE

- **ALWAYS** make certain that the proper power or extension cord has been selected for the job.

## TRANSPORTING SAFETY

### CAUTION

- **NEVER** allow any person or animal to stand underneath the equipment while lifting.

### NOTICE

- **ALWAYS** make sure forklift forks are inserted as far as possible into the pockets (if applicable) when lifting the mixer.
- **ALWAYS** shut down the engine before transporting.
- **NEVER** lift the equipment while the engine is running.
- Tighten the fuel tank cap securely and close the fuel cock to prevent fuel from spilling.
- **DO NOT** lift the machine to unnecessary heights.
- **ALWAYS** tie down equipment during transport by securing the equipment with rope.
- **NEVER** tip the engine to extreme angles during lifting as this may cause oil to gravitate into the cylinder head, making the engine difficult to start.

# SAFETY INFORMATION

## TOWING SAFETY

### ⚠ CAUTION

- In addition to meeting **Department of Transportation (DOT) safety towing regulations**, check your local county or state safety towing regulations before towing the mixer.
- In order to reduce the possibility of an accident while transporting the mixer on public roads, **ALWAYS** make sure the towing vehicle is mechanically sound and in good operating condition.
- **ALWAYS** shut down the engine before transporting and place the fuel valve in the **OFF** position.
- **ALWAYS** inspect the hitch and coupling for wear. **NEVER** tow a mixer with defective hitches, couplings, chains, etc.
- Check the tire air pressure on both towing vehicle and mixer. **Mixer tires should be inflated to 50 psi cold.** Also check the tire tread wear on the vehicle and mixer.
- **ALWAYS** make sure the mixer is equipped with a **safety chain**.
- **ALWAYS** properly attach the mixer's safety chains to the towing vehicle.
- The maximum speed for highway towing is **55 MPH** unless posted otherwise. Recommended off-road towing is not to exceed **15 MPH** or less depending on type of terrain.
- Avoid sudden stops and starts. These can cause skidding or jackknifing. Smooth, gradual starts and stops will improve towing.
- Avoid sharp turns to prevent rolling.
- The mixer should be adjusted to a level position at all times when towing.
- Raise and lock the mixer wheel stand in the **UP** position when towing.
- Place **chock blocks** underneath the mixer wheels to prevent **rolling** while parked.

## ENVIRONMENTAL SAFETY/DECOMMISSIONING

### NOTICE

Decommissioning is a controlled process used to safely retire a piece of equipment that is no longer serviceable. If the equipment poses an unacceptable and unrepairable safety risk due to wear or damage or is no longer cost effective to maintain (beyond life-cycle reliability) and is to be decommissioned (demolition and dismantlement), follow the rules below.

- **DO NOT** pour waste or oil directly onto the ground, down a drain or into any water source.
- Contact your country's Department of Public Works or a recycling agency in your area and arrange for proper disposal of any electrical components, waste or oil associated with this equipment.
- When the life cycle of this equipment is over, remove the battery (if equipped) and bring it to an appropriate facility for lead reclamation. Use safety precautions when handling batteries that contain sulfuric acid.
- When the life cycle of this equipment is over, it is recommended that the mixer frame and all other metal parts be sent to a recycling center.



Metal recycling involves the collection of metal from discarded products and its transformation into raw materials to use in manufacturing a new product.

Recyclers and manufacturers alike promote the process of recycling metal. Using a metal recycling center promotes energy cost savings.

## EMISSIONS INFORMATION

### NOTICE

The gasoline engine used in this equipment has been designed to reduce harmful levels of carbon monoxide (CO), hydrocarbons (HC) and nitrogen oxides (NOx) contained in gasoline exhaust emissions.

This engine has been certified to meet US EPA evaporative emissions requirements in the installed configuration.

Attempting to modify or make adjustments to the engine emission system by unauthorized personnel without proper training could damage the equipment or create an unsafe condition.

Additionally, modifying the fuel system may adversely affect evaporative emissions, resulting in fines or other penalties.

### Emission Control Label

The emission control label is an integral part of the emission system and is strictly controlled by regulation(s).

The label must remain with the engine for its entire life.

If a replacement emission label is needed, please contact your authorized engine distributor.

# SPECIFICATIONS/DIMENSIONS

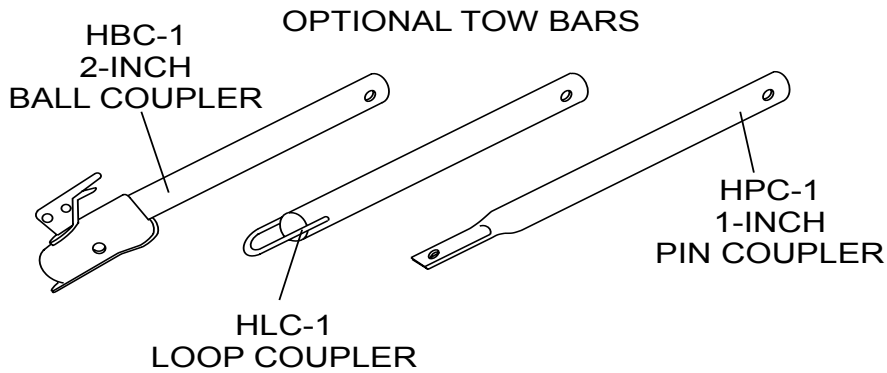
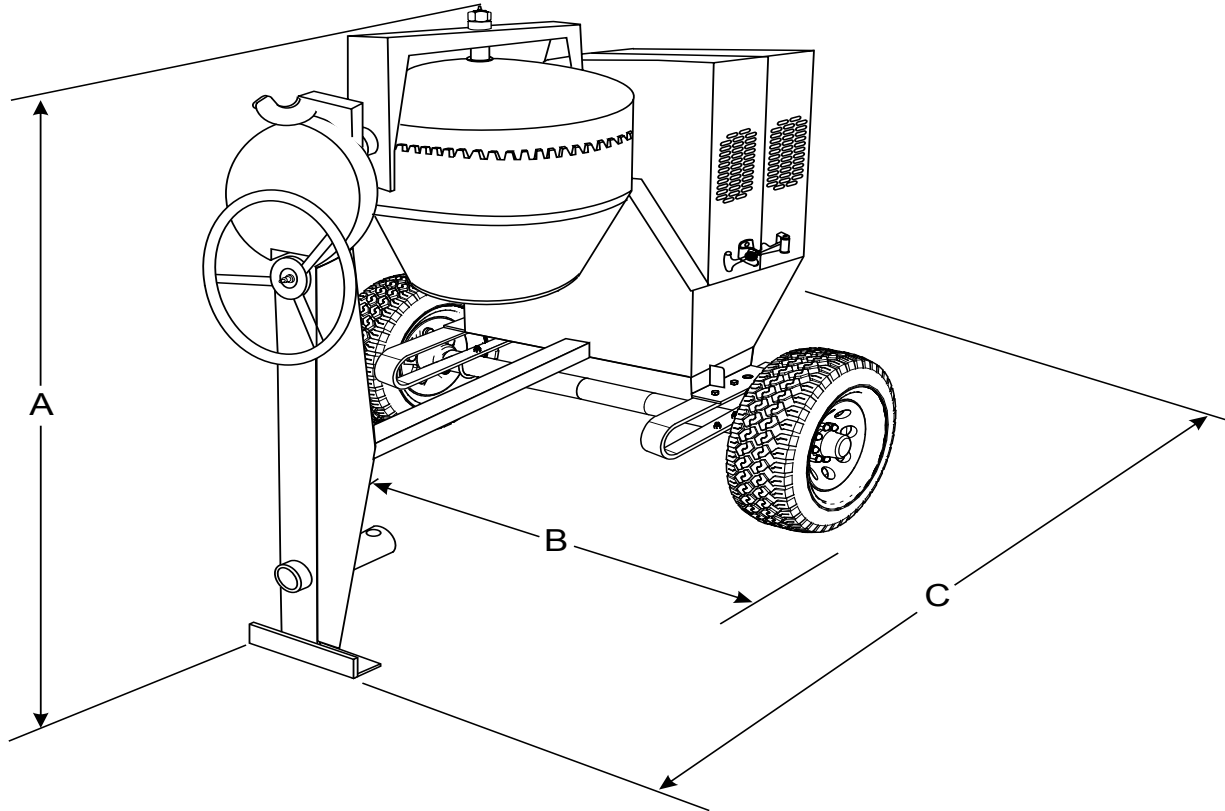

**Figure 1. Dimensions**

<b>Table 1. MC12PH Concrete Mixer Specifications</b>	
Height (A)	67.5 in. (1,460.5 mm)
Width (B)	56 in. (1,422.4 mm)
Length (C)	83 in. (2,108.2 mm)
Maximum Mixing Capacity	12 cu. ft. (339.8 liters)
Drum Opening	20 in. (508 mm)
Bag Capacity	1.5 ~ 2 bags
Weight	1,000 lbs. (543.59 Kg)

# ENGINE SPECIFICATIONS

<b>Table 2. MC12PH Noise</b>	
<b>Model</b>	<b>MC12PH</b>
Guaranteed ISO 11201:2010 Based Sound Pressure Level at Operator Station in dB(A)	TBD

**NOTES:**

1. *Sound Pressure and Power Levels are “A” weighted Measures per ISO 226:2003 (ANSI S1.4-1981). They are measured with the operating condition of the machine which generates the most repeatable but highest values of the sound levels. Under normal circumstances, the sound level will vary depending on the condition of the material being worked upon..*

<b>Table 3. Engine Specifications/Dimensions</b>	
<b>Model</b>	<b>GX340UT2QA2/GX340UT2QAP2</b>
Type	Air cooled 4-stroke OHV petrol engine, 25° inclined cylinder, horizontal shaft, cast iron sleeve
Bore X Stroke	3.2 in. X 2.5 in. (88 mm x 64 mm)
Displacement	389 cm <sup>3</sup>
Max. Output	10.7 H.P. (7.9 kW) @ 3600 RPM
Continuous Rated Power	5.6 kW (7.5 HP)/3,000 rpm 6.3 kW (8.4 HP)/3,600 rpm
Max. Net Torque	26.4 Nm/2.69 kgfm/2,500 rpm
Ignition System	Digital CDI with variable ignition timing
Fuel Tank Capacity	1.61 U.S. Gallons (Approx. 6.1 Liters)
Fuel	Unleaded Gasoline
Lube Oil Capacity	1.06 qt. (1.1 liters)
Oil Type	4-Stroke API, SF or SG SAE 10W-30 General Use
Speed Control Method	Centrifugal Flyweight Type
Cooling System	Forced Air
Starting Method	Recoil Start
Spark Plug Type	BPR6ES NGK
Spark Plug Gap	0.028-0.031 in. (0.70 - 0.80 mm)
Dimension (L x W x H)	16.0 x 18.1 X 17.6 in. (406 X 460 X 448 mm)
Dry Net Weight	69.9 lbs (31.7 Kg.)

## APPLICATION

This mixer is intended ***only*** for the production of **concrete**. The mixer must be used for its intended purpose and is not suitable for the mixing of **flammable** or **explosive** substances. The mixer ***must not be used*** in an explosive atmosphere.

## POWER PLANTS

The Multiquip MC12PH mixer is powered by a 10.7 HP, air-cooled, 4-stroke gasoline engine. Refer to Table 3 to for specific engine.

## HARDWARE

Check all hardware on the mixer before starting. Periodically inspect all hardware. Loose hardware can contribute to early component failure and poor performance. Use Table 4 as general guideline when the torquing of mixer hardware is required. Remember to keep all mixer hardware components tight.

**Table 4. Hardware Torque Recommendations**

Hardware Diameter	Torque (ft-lbs)
5/16-inch x 18	14
3/8-inch x 16	24
3/8-inch x 24	37
1/2-inch x 13	39
1/2-inch x 13 (Grade 8)	90

## ENGINE MAINTENANCE

For basic engine maintenance, refer to the engine maintenance section in this manual. For more detailed engine maintenance, refer to the Honda Engine Owner's manual furnished with the engine.

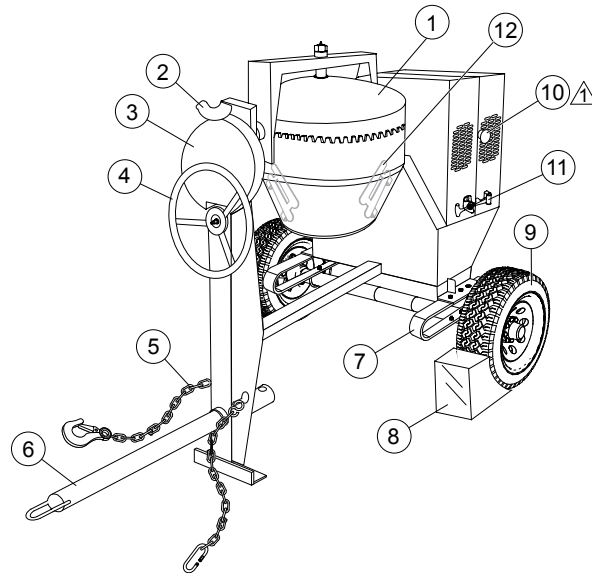

NOTE:  
▲ SHOWN FOR CLARITY  
ACTUAL LOCATION IS ON OPPOSITE SIDE

**Figure 2. Mixer Major Components**

1. **Plastic Mixing Drum** — The Multiquip MC12PH uses a 12 cu. ft **plastic** mixing drum. This drum is to be used for mixing of concrete. Always clean the drum after each use. **DO NOT** use this mixing drum for the mixing of **volatile or hot liquids**.
2. **Dump Latch** — To rotate the mixing drum, this latch must be in the up position. To lock the drum, place the latch in the down position.
3. **Dump Gear Guard** — **NEVER** operate the mixer with this guard removed. Its purpose is to prevent dirt and debris from entering the dump gear. In addition operator clothing could become entangled in the dump gear, causing severe injury and bodily harm.
4. **Handwheel** — Turn this wheel clockwise or counterclockwise to rotate the mixing drum. Remember the dump latch must be in the **up position** in order for the mixing drum to be rotated.
5. **Safety Chain** — This mixer uses a 3/16-inch thick, 72 inches long zinc-plated safety chain. **ALWAYS** connect the safety chain when towing.
6. **Tow Bar** — This mixer uses various towing bars, please reference the frame assembly drawing and parts list in this manual to determine which tow bar meets your requirements.
7. **Cantilever Suspension** — This mixer uses a cantilever type suspension. Check the mounting hardware for bolt hole elongation and tightness. See maintenance section of this manual for recommended maintenance.
8. **Chock Blocks** — Place these blocks (not included as part of the mixer package) under each mixer wheel to prevent rolling, when mixer is not connected to the towing vehicle.
9. **Tires Ply** — The tire ply (layers) number is rated in letters. This mixer uses 13-inch 2-ply tires. Replace with only recommended type tires.
10. **ON/OFF Switch** — This switch is located on the side of the mixer frame. When activated it will shut down the engine. Pull out when starting the engine.
11. **Cabinet/Latch** — Encloses engine and electric motor. **NEVER** run mixer with cabinet removed. Use latches to secure engine compartment cabinet.
12. **Mixing Blades** — Used for the mixing of concrete. When blades show signs of wear, replace the blades.

# ENGINE COMPONENTS

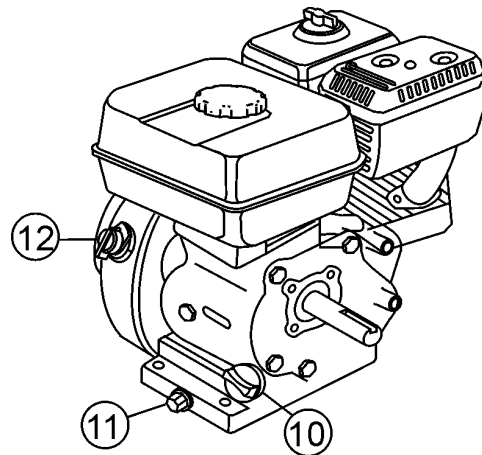
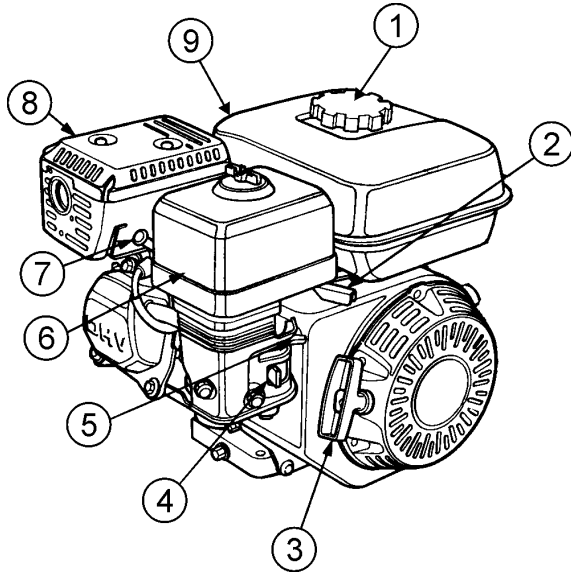

Figure 3. Engine Components

## INITIAL SERVICING

The engine (Figure 3) must be checked for proper lubrication and filled with fuel prior to operation. Refer to the manufacturer's engine manual for instructions and details of operation and servicing.

1. **Fuel Filler Cap** – Remove this cap to add unleaded gasoline to the fuel tank. Make sure cap is tightened securely. **DO NOT** over fill.

### DANGER



Add fuel to the tank only when the engine is stopped and has had an opportunity to cool down. In the event of a fuel spill, **DO NOT** attempt to start the engine until the fuel residue has been completely wiped up and the area surrounding the engine is dry.

2. **Throttle Lever** – Used to adjust engine RPM speed. This lever is connect to the throttle lever cable located on the handle bars. Reference throttle cable installation procedure in this manual.
3. **Recoil Starter (pull rope)** – Manual-starting method. Pull the starter grip until resistance is felt, then pull briskly and smoothly.
4. **Fuel Valve Lever** – **OPEN** to let fuel flow, **CLOSE** to stop the flow of fuel.
5. **Choke Lever** – Used in the starting of a cold engine, or in cold weather conditions. The choke enriches the fuel mixture.

6. **Air Cleaner** – Prevents dirt and other debris from entering the fuel system. Remove wing-nut on top of air filter canister to gain access to filter element.

### NOTICE

Operating the engine without an air filter, with a damaged air filter, or a filter in need of replacement will allow dirt to enter the engine, causing rapid engine wear.

7. **Spark Plug** – Provides spark to the ignition system. Set spark plug gap according to engine manufacturer's instructions. Clean spark plug once a week.
8. **Muffler** – Used to reduce noise and emissions. **NEVER** touch when **hot!**
9. **Fuel Tank** – Fill with unleaded gasoline. Refer to Table 3 for fuel tank capacity. For additional information refer to Honda engine owner's manual.
10. **Dipstick/Oil Filler Cap** – Remove this cap to determine if the engine oil is low. Add oil through this filler port as recommended in Table 5.
11. **Oil Drain Plug** – Remove this plug to remove oil from the engine's crankcase.
12. **Engine ON/OFF Switch** – **ON** position permits engine starting, **OFF** position stops engine operation.



# TOWING GUIDELINES

## TOWING SAFETY PRECAUTIONS

### CAUTION

Check with your county or state safety towing regulations department before towing your *mixer*.

To reduce the possibility of an accident while transporting the mixer on public roads, always make sure that the mixer towing components and the towing vehicle are in good operating condition and both units are mechanically sound.

The following list of suggestions should be used when towing the mixer:

- Make sure that the hitch and coupling of the towing vehicle are rated equal to, or greater than the trailer "gross vehicle weight rating" (GVWR).
- **ALWAYS** inspect the hitch and coupling for wear. **NEVER** tow the mixer with defective hitches, couplings, chains etc.
- **CHECK** the tire air pressure on both the towing vehicle and the trailer. Also check the tire tread wear on both vehicles.
- **ALWAYS** make sure the mixer is equipped with a "**Safety Chain.**"
- **ALWAYS** attach trailer's safety chain to the frame of towing vehicle.
- **ALWAYS** make sure that the towing vehicle's directional, backup, and brake lights are working properly.
- Remember in most cases the maximum speed unless otherwise posted for highway towing is 45 MPH, however before towing your mixer, check your local state, and county vehicle towing requirements. Recommended off-road towing is not to exceed **10 MPH** or less depending on type of terrain.
- Place **chocked blocks** underneath wheels to prevent **rolling**, while parked, if disconnected from towing vehicle.
- Inflate tires to correct pressure, inspect tires for cuts, and excessive wear. See Table 16 (Tire Wear Troubleshooting).
- When towing of the mixer is required, place the drum in the up position (mouth facing upwards).

- **ALWAYS** make sure that the fuel valve lever is in the OFF position (gasoline models only).
- Check wheel mounting lug nuts with a torque wrench. Torque wheel lug nuts as described in the maintenance section of this manual.
- Check tightness of U-clamp nuts, torque suspension hardware as referenced in the maintenance section of this manual.
- Avoid sudden stops and starts. This can cause skidding, or jackknifing. Smooth, gradual starts and stops will improve gas mileage.
- Avoid sharp turns to prevent rolling.

### CAUTION

If the mixer tow bar is deformed or damaged replace entire tow bar. **NEVER** tow the mixer with a defective tow bar. There exist the possibility of the trailer separating from the **towing vehicle**.

## TOW BAR TO VEHICLE (COUPLER ONLY)

1. Check the vehicle hitch ball, and mixer's coupler for signs of wear or damage. Replace any parts that are worn or damaged before towing.
2. Use only a 2-inch ball diameter (towing vehicle), this will match the mixer's 2-inch coupler. Use of any other ball diameter will create an extremely dangerous condition which can result in separation of the coupler and ball or ball failure.
3. After tow bar has been connected to mixer (see next page), attach mixer's coupler to the hitch ball on the towing vehicle securely and make sure the lock lever is in the down position (locked).

## MIXER TOW BAR VEHICLE (PINTLE AND LOOP)

1. Make sure the bumper on the towing vehicle is equipped to handle either a pintle or loop type tow bar configuration.
2. After tow bar has been connected to mixer (see next page), secure either type of tow bar to the towing vehicle, following state and county towing regulations
3. As a minimum, use a 1/2-inch bolt and nylock nut grade 5 when securing either tow bar to the towing vehicle.

# SAFETY CHAIN CONNECTION

## CAUTION

**NEVER** tow the mixer with the safety chain removed. The safety chain is intended to prevent complete separation of the mixer from the towing vehicle in the event of a tow bar failure.

## TOW BAR TO MIXER CONNECTION

Reference Figure A for the installation of the safety chain.

1. Insert the tow bar through the round opening at the bottom of the mixer stand.

Align the hole on the tow bar with the hole on the mixer frame, and insert 1/2-inch bolt through tow bar and frame. Secure tow bar to frame with 1/2-inch nylock nut. Tighten to 40 ft.-lbs.

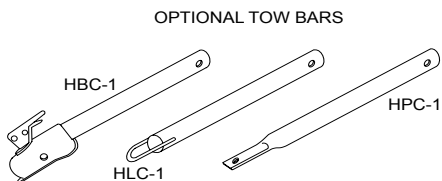
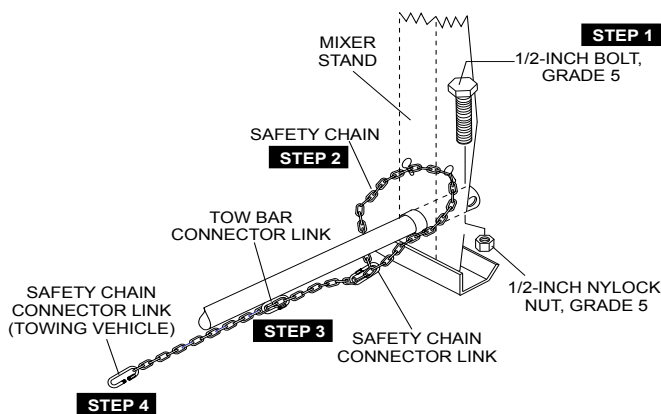

Figure A. Tow Bar and Safety Chain Installation

2. Route the safety chain through the holes just above the tow bar, located on each side of the mixer stand.

Loop the chain together and place under the tow bar. Secure the loop with the connector link.

3. Extend the safety chain along the length of the tow bar, looping it through the tow bar's connector link. Remove any excess chain slack.

4. Connect the free end of (connector link) the safety chain to the towing vehicle. Remember it is critical that the length of the chain be properly adjusted, to prevent the draw bar and the front of the mixer stand from dropping to the the ground (contact) in the event the draw bar becomes disconnected from the towing vehicle.

## CAUTION

**DO NOT** tow or lift the mixer unless the mixing drum is completely empty.

## CAUTION

Use a lifting device to lift tow bar onto vehicle coupler. If lifting device is not available, have 2 persons of similar height lift the tow bar. When lifting, do not attempt to lift by bending forward. Bend hips and knees to squat down to your load, keep it close to your body, and straighten your legs to lift.

## BEFORE STARTING

1. Read all safety instructions at the beginning of manual.
2. Clean the unit, removing dirt and dust, particularly the engine cooling air inlet, carburetor and air cleaner.
3. Check the air filter for dirt and dust. If air filter is dirty, replace air filter with a new one as required.
4. Check carburetor for external dirt and dust. Clean with dry compressed air.
5. Check fastening nuts and bolts for tightness.

### CAUTION



**ALWAYS** wear approved eye and hearing protection while operating the mixer.

### CAUTION



**NEVER** place hands or feet inside the engine guard cover while the engine is running. **ALWAYS** shut the engine down before performing any kind of maintenance service on the mixer.

## ENGINE OIL CHECK

1. To check the engine oil level, place the unit on secure level ground with the engine stopped.
2. Remove the filler dipstick from the engine oil filler hole (Figure 4) and wipe it clean.

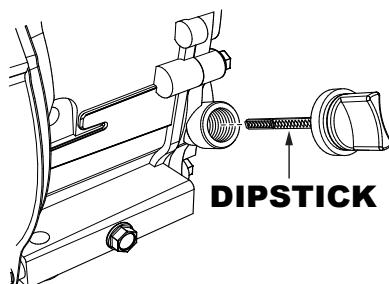
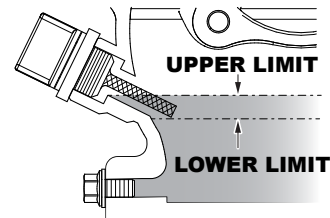

**Figure 4. Engine Oil Dipstick (Removal)**

3. Insert and remove the dipstick without screwing it into the filler neck. Check the oil level shown on the dipstick.
4. If the oil level is low (Figure 5), fill to the edge of the oil filler hole with the recommended oil type (Table 5). Maximum oil capacity is 2.33 pints (1.09 liters).

### NOTICE

Reference engine manufacturer's manual for specific servicing instructions.



**Figure 5. Engine Oil Dipstick (Oil Level)**

**Table 5. Oil Type**

Season	Temperature	Oil Type
Summer	25°C or Higher	SAE 10W-30
Spring/Fall	25°C ~ 10°C	SAE 10W-30/20
Winter	0°C or Lower	SAE 10W-10

## FUEL CHECK

### DANGER



Motor fuels are highly flammable and can be dangerous if mishandled. **DO NOT** smoke while refueling. **DO NOT** attempt to refuel the mixer if the engine is hot or running.

1. Remove the gasoline cap located on top of fuel tank.
2. Visually inspect to see if fuel level is low. If fuel is low, replenish with unleaded fuel.
3. When refueling, be sure to use a strainer for filtration. **DO NOT** top-off fuel. Wipe up any spilled fuel immediately.

## BLADE CHECK

Check for worn blades.

If using a plastic drum, replace the blades using the part numbers referenced in the parts section of this manual.

## V-BELT CHECK

Visually examine the V-belt (Figure 6) and determine if it is full of tiny cracks, frayed, has pieces of rubber missing, is peeling or otherwise damaged.

Also, examine the belt and determine if it is **oil soaked** or **"glazed"** (hard shiny appearance on the sides of the belt). Either of these two conditions can cause the belt to run hot, which can weaken it and increase the danger of it breaking.

If the V-belt exhibits any of the above wear conditions replace the V-belt immediately.

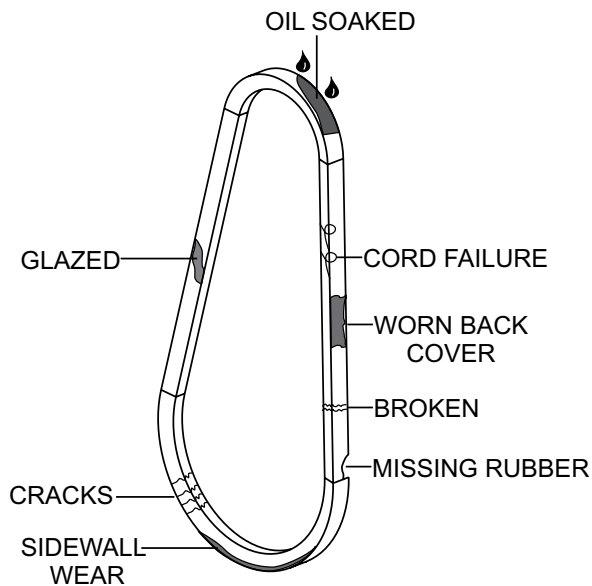

Figure 6. V-Belt Inspection

## START/STOP SWITCH

This unit has been equipped with a start/stop switch (Figure 7), which should be tested every time the unit is started.

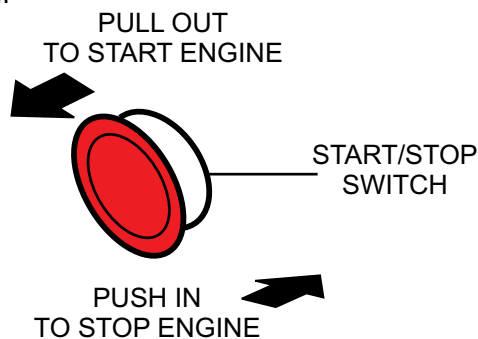

Figure 7. Start/Stop Switch

# START-UP

This section is intended to assist the operator with the initial start-up of the unit. It is extremely important that this section be read carefully before attempting to use the mixer in the field. **DO NOT** use your mixer until this section is thoroughly understood.



## WARNING

Failure to understand the operation of the mixer could result in severe damage to the mixer or personal injury. Reference Figure 2 for the location of any components referenced in this manual.

## CAUTION



**NEVER** operate the mixer in a confined area or enclosed area structure that does not provide ample free flow of air.

The following steps outline the procedure for starting the engine.

1. Move the fuel shut-off lever (Figure 8) to the ON position.

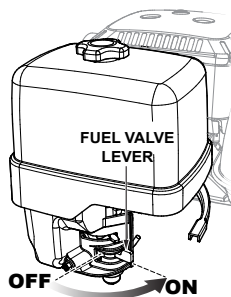

Figure 8. Fuel Shut-Off Lever

2. To start a cold engine, move the choke lever (Figure 9) to the CLOSED position.

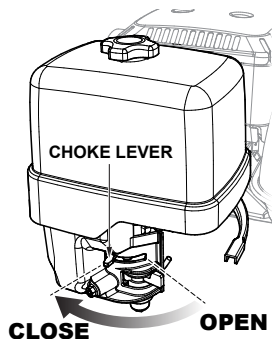

Figure 9. Choke Lever

3. Move the throttle lever (Figure 10) away from the slow position, about 1/3 of the way toward the fast position.

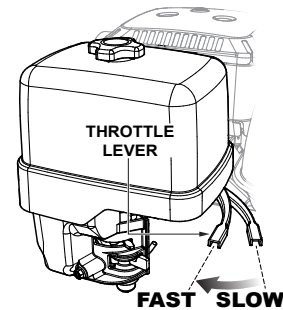

Figure 10. Throttle Lever

4. Turn the engine switch (Figure 11) to the ON position.

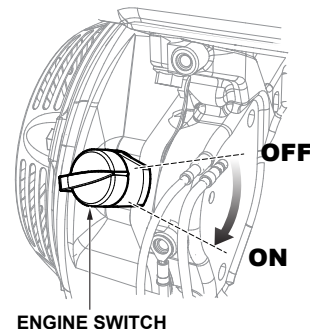

Figure 11. Engine On/Off Switch

5. Located at the rear of the mixer frame is the main **start/stop** button (Figure 12). Pull this button outward to start the engine.

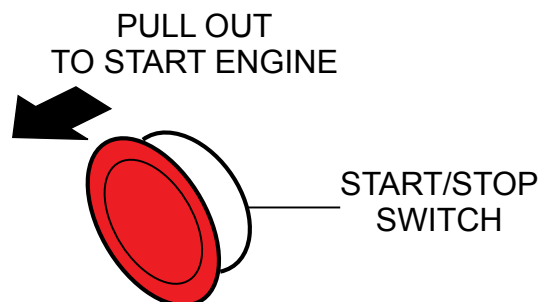

Figure 12. Engine Start/Stop Button

## START-UP/OPERATION

6. Pull the **starter grip** (Figure 13) lightly until you feel resistance, then pull briskly. Return the starter grip gently.

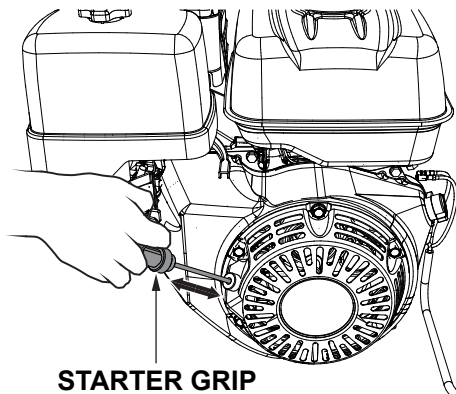

Figure 13. Starter Grip

### OPERATION

1. To position the drum, make sure the mixer is placed on firm level ground, then **pull up** on the **dump latch** (Figure 14) and turn the **hand wheel** until the drum is at the desired position. Once the drum is at the desired position, **pull down** on the dump latch to lock the drum in position.

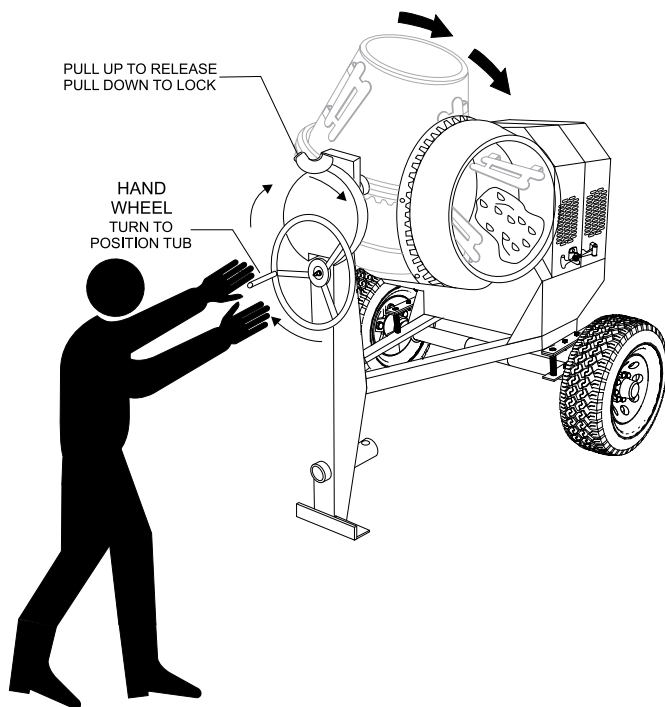

Figure 14. Mixing Drum Positioning

### CAUTION



**NEVER** stand in front or behind the mixing drum while it is being placed in the dump position. Stay clear of the mixing drum while it is being positioned.

2. As the drum rotates, use a shovel (Figure 15) to place the cement mix inside the drum, add water as required. Be careful to only place the **tip** of the shovel inside the drum.

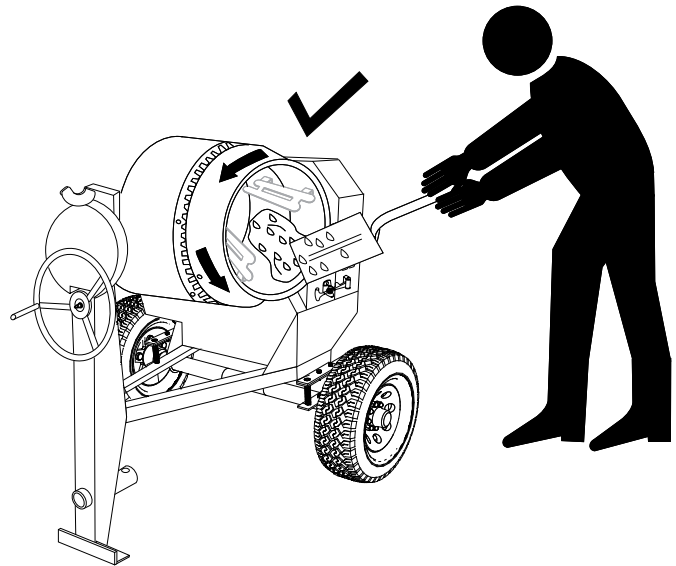
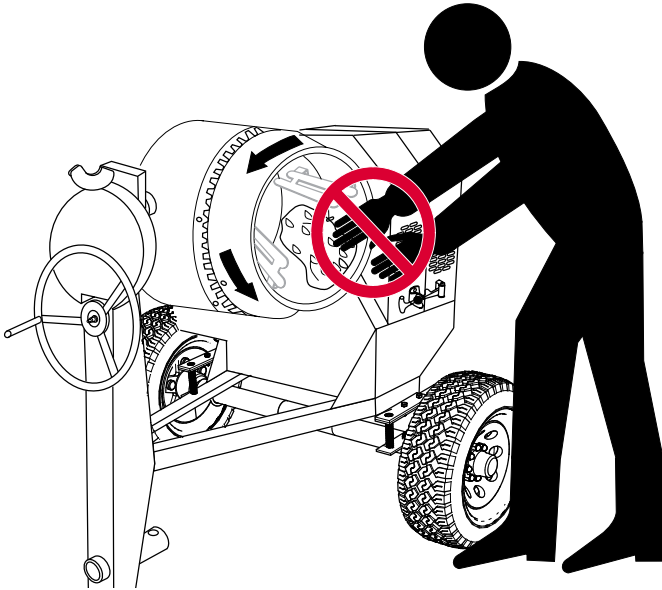

Figure 15. Filling Mix Drum

3. Placing the shovel all the way inside the drum (Figure 16) will cause the shovel to strike the blades. This condition will make the shovel rotate, and could cause injury to personnel. NEVER place hands inside the mixing drum while it is rotating.



**Figure 16. Filling Mixing Drum**

## STOPPING THE MIXER

1. Push the main **start/stop** switch (Figure 17) inward to stop the engine.

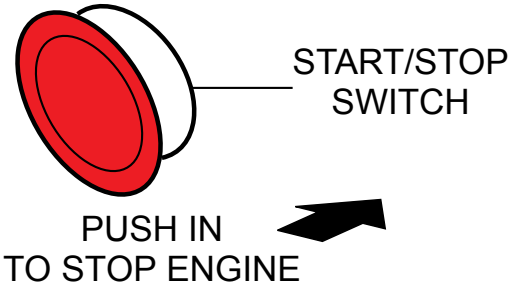

**Figure 17. Start/Stop Button (Stop Position)**

2. Place fuel shut-off lever in the OFF position.
3. Clean drum of all debris and foreign matter.

## MAINTENANCE (ENGINE)

Use Table 6 as a general maintenance guideline when servicing your engine. For more detail engine maintenance information, refer to the engine owner's manual supplied with your engine.

<b>Table 6. Engine Maintenance Schedule</b>							
DESCRIPTION (3)	OPERATION	BEFORE	FIRST MONTH OR 10 HRS.	EVERY 3 MONTHS OR 25 HRS.	EVERY 6 MONTHS OR 50 HRS.	EVERY YEAR OR 100 HRS.	EVERY 2 YEARS OR 200 HRS.
Engine Oil	Check	X					
	Change		X				
Air Cleaner	Check	X					
	Change			X (1)			
All Nuts and Bolts	Re-tighten if necessary	X					
Spark Plugs	Check/Clean				X		
	Replace						X
Cooling Fins	Check				X		
Spark Arrester	Clean					X	
Fuel Tank	Clean					X	
Fuel Filter	Check					X	
Idle Speed	Check/ Adjust					X (2)	
Valve Clearance	Check/ Adjust						X (2)
Fuel Lines	Check	Every 2 years (replace if necessary) (2)					

(1) Service more frequently when used in **DUSTY** areas.

(2) These items should be serviced by your service dealer, unless you have the proper tools and are mechanically proficient. Refer to the HONDA Shop Manual for service procedures.

(3) For commercial use, log hours of operation to determine proper maintenance intervals.



# MAINTENANCE (ENGINE)

## MAINTENANCE

Perform the scheduled maintenance procedures as defined by Table 6 and below:

### DAILY

- Thoroughly remove dirt and oil from the engine and control area. Clean or replace the air cleaner elements as necessary. Check and retighten all fasteners as necessary. Check the gearbox for oil leaks. Repair or replace as needed.

### WEEKLY

- Remove the fuel filter cap and clean the inside of the fuel tank.
- Remove or clean the filter at the bottom of the tank.
- Remove and clean the spark plug (Figure 18), then adjust the spark gap to 0.024 ~0.028 inch (0.6~0.7 mm). This unit has electronic ignition, which requires no adjustments.

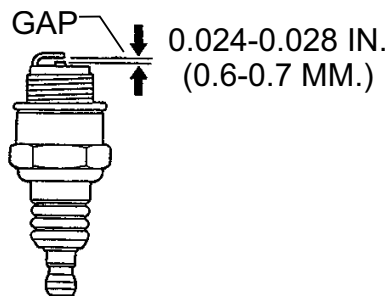

Figure 18. Spark Plug Gap

## ENGINE OIL

- Drain the engine oil when the oil is warm as shown in Figure 19.
- Remove the oil drain bolt and sealing washer and allow the oil to drain into a suitable container.
- Replace engine oil with recommended type oil as listed in Table 5. For engine oil capacity, see Table 3 (Engine Specifications). **DO NOT** overfill.
- Install drain bolt with sealing washer and tighten securely.

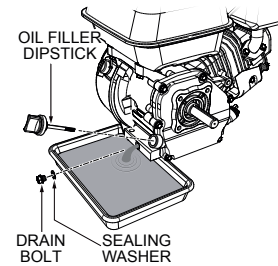

Figure 19. Engine Oil (Draining)

## ENGINE AIR CLEANER

- Remove the air cleaner cover and foam filter element as shown in Figure 20.
- Tap the paper filter element (Figure 20) several times on a hard surface to remove dirt, or blow compressed air [not exceeding 30 psi (207 kPa, 2.1 kgf/cm<sup>2</sup>)] through the filter element from the air cleaner case side. **NEVER** brush off dirt. Brushing will force dirt into the fibers. Replace the paper filter element if it is excessively dirty.
- Clean foam element in warm, soapy water or nonflammable solvent. Rinse and dry thoroughly. Dip the element in clean engine oil and completely squeeze out the excess oil from the element before installing.

### **! DANGER**

**DO NOT** use gasoline as a cleaning solvent to avoid creating the risk of fire or an explosion.

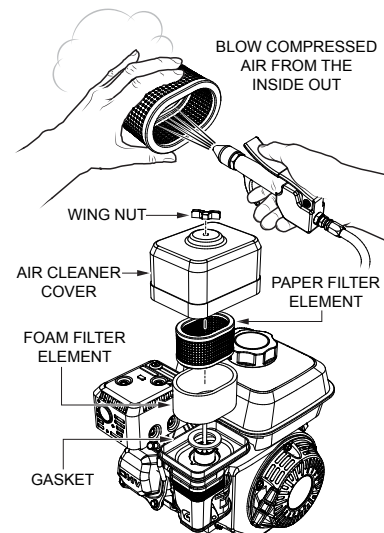

Figure 20. Engine Air Cleaner

# MAINTENANCE (ENGINE)

## BALL SOCKET AND CLAMP FACE MAINTENANCE

1. If the towing vehicle is equipped with a ball socket, smear socket periodically with multi-purpose grease. This will keep the ball socket well lubricated.
2. Periodically oil **pivot points** and **clamp face** surfaces of coupler with SAE 30 WT. motor oil.
3. When parking or storing your mixer. Keep the coupler off the ground so dirt will not build up in the ball socket.

## GREASE FITTINGS (ZERK) MAINTENANCE (MIXER)

There are grease fittings (Figure 21) that will require lubrication. Lubricate these fittings **once a month**. Use lithium base grease, grade NO.1.

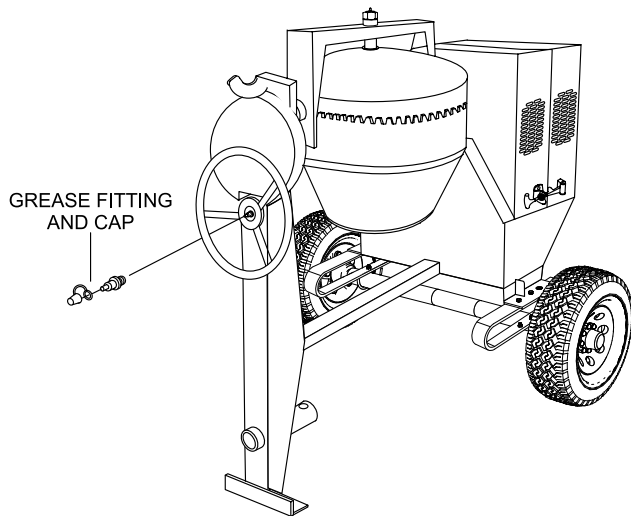

Figure 21. Grease Fittings Mixer

## WHEEL BEARINGS

1. After every 3 months of operation, remove the hub dust cap and inspect the wheel bearings (Figure 22). Once a year, or when required, disassemble the wheel hubs remove the old grease and repack the bearings forcing grease between rollers, cone and cage with a good grade of high speed wheel bearing grease (never use grease heavier than 265 A.S.T.M. penetration ("No. 2.")).

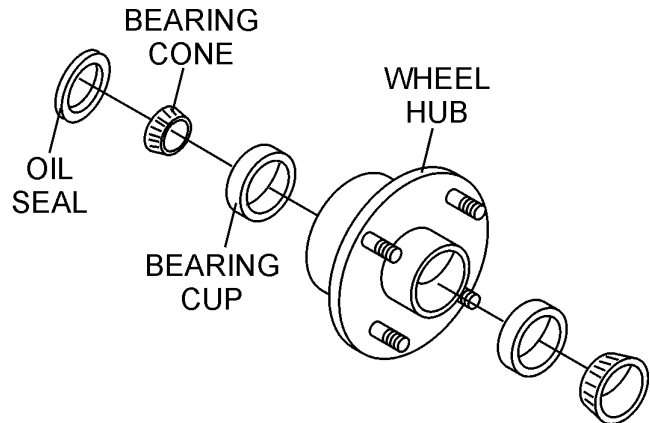

Figure 22. Wheel Hub and Bearings

2. Fill the wheel hub (Figure 22) with grease to the inside diameter of the outer races and also fill the hub grease cap. Reassemble the hub and mount the wheel. Then tighten the adjusting nut, at the same time turn the wheel in both directions, until there is a slight bind to be sure all the bearing surfaces are in contact.

Then back-off the adjusting nut 1/6 to 1/4 turn or to the nearest locking hole or sufficiently to allow the wheel to rotate freely within limits of .001" to .010" end play. Lock the nut at this position. Install the cotter pin and dust cap, and tighten all hardware.

## MIXER CLEANING

1. For thorough mix and longer drum life, **always** wash drum out after each use.

# MAINTENANCE (ENGINE)

- NEVER!** pour or spray water over the engine or electric motor.

## Tires/Wheels/Lug Nuts

Tires and wheels are a very important and critical components of the trailer. When specifying or replacing the trailer wheels it is important the wheels, tires, and axle are properly matched.

**WARNING**



**DO NOT** attempt to repair or modify a wheel.  
**DO NOT** install an inter-tube to correct a leak through the rim. If the rim is cracked, the air pressure in the inter-tube may cause pieces of the rim to explode (break-off) with great force and can cause serious eye or bodily injury.

## Tires Wear/Inflation





Tire inflation pressure is the most important factor in tire life. Pressure should be checked cold before operation. **DO NOT** bleed air from tires when they are hot. Check inflation pressure weekly during use to insure the maximum tire life and tread wear.

**WARNING**



**ALWAYS** wear safety glasses when removing or installing force fitted parts. Failure to comply may result in serious injury.

Table 7 (Tire Wear Troubleshooting) will help pinpoint the cause of tire wear.

Table 7. Tire Wear Troubleshooting			
Wear Pattern		Cause	Solution
	Center Wear	Over Inflation	Adjust pressure to particular load per tire manufacturer
	Edge Wear	Under Inflation	Adjust pressure to particular load per tire manufacturer.
	Side Wear	Loss of chamber or	Make sure load does not exceed axle rating. Align wheels.
	Toe Wear	Incorrect toe-in	Align wheels.
		Out of balance	Check bearing adjustment and balance tires.

# MAINTENANCE (ENGINE)

## Suspension

The cantilever suspension springs and associated components (Figure 23) should be visually inspected every 6,000 miles for signs of excessive wear, elongation of bolt holes, and loosening of fasteners. Replace all damaged parts (suspension) immediately. Torque locknut securing U-clamp to spring leaf between 45 and 50 ft.-lbs.

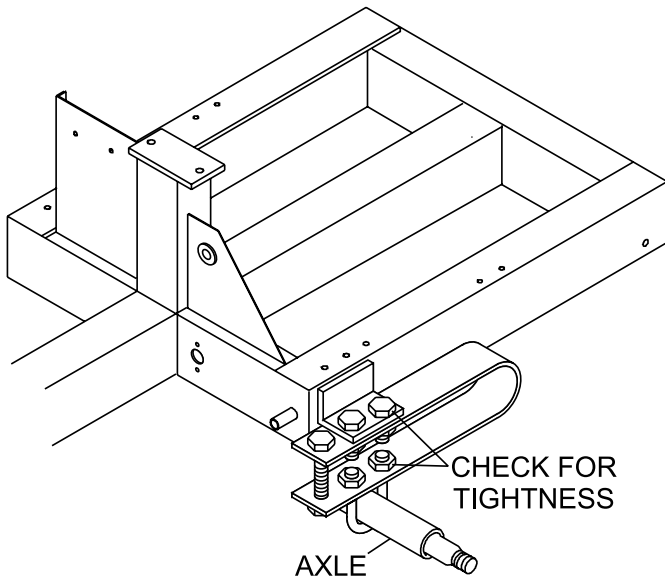

Figure 23. Suspension Components

## Lug Nut Torque Requirements

It is extremely important to apply and maintain proper wheel mounting torque. Be sure to use only the fasteners matched to the cone angle of the wheel. Proper procedure for attachment of the wheels is as follows:

1. Start all wheel lug nuts by hand.
2. Torque all lug nuts in sequence. See Figure 24. **DO NOT** torque the wheel lug nuts all the way down. Tighten each lug nut in 3 separate passes as defined by Figure 24.

Table 8. Tire Torque Requirements

Wheel Size	First Pass FT-LBS	Second Pass FT-LBS	Third Pass FT-LBS
12"	20-25	35-40	50-65
13"	20-25	35-40	50-65
14"	20-25	50-60	90-120
15"	20-25	50-60	90-120
16"	20-25	50-60	90-120

### NOTICE

**NEVER** use an pneumatic air gun to tighten wheel lug nuts.

3. After first road use, retorque all lug nuts in sequence. Check all wheel lug nuts periodically.

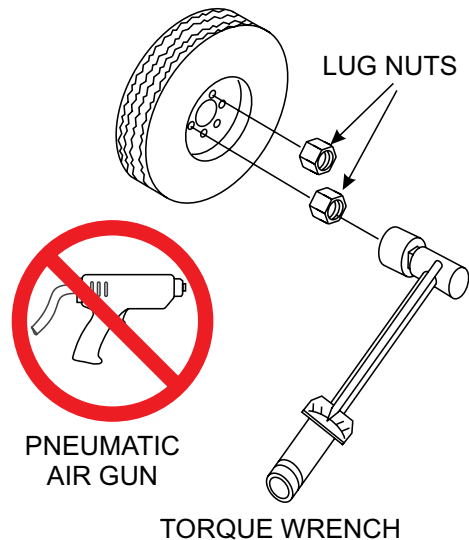
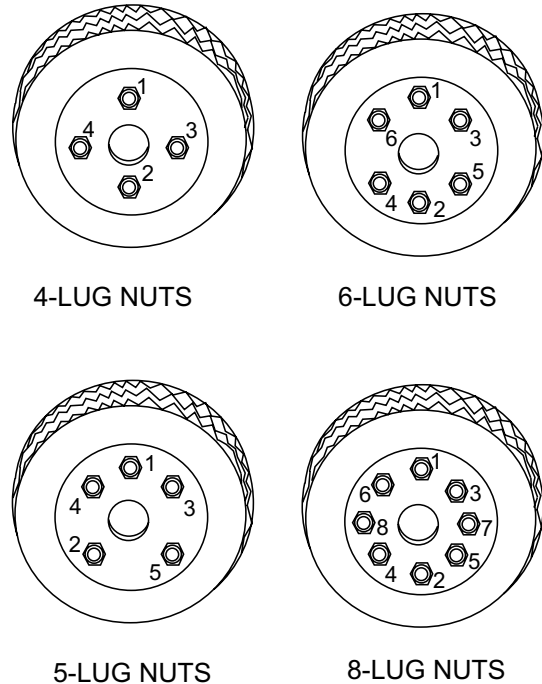

Figure 24. Lug Nuts Tightening Sequence

### **MIXER STORAGE**

For storage of the mixer for over 30 days, the following is recommended:

- Drain the fuel tank completely, or add STA-BIL to the fuel.
- Run the engine until the fuel is completely consumed.
- Completely drain used oil from the engine crankcase and fill with fresh clean oil, then follow the procedures described in the engine manual for engine storage.
- Clean the entire mixer and engine compartment.
- Place the mixing drum in the down position (mouth facing downward).
- Cover the mixer and place it a clean dry area, that is protected from harsh elements.

# TROUBLESHOOTING

<b>Troubleshooting (Engine)</b>		
<b>Symptom</b>	<b>Possible Problem</b>	<b>Solution</b>
Difficult to start, fuel is available, but no spark at spark plug.	Spark plug bridging?	Check gap, insulation or replace spark plug.
	Carbon deposit on spark plug?	Clean or replace spark plug.
	Short circuit due to deficient spark plug insulation?	Check spark plug insulation, replace if worn.
	Improper spark plug gap?	Set to proper gap.
	Fuel reaching carburetor?	Check fuel line.
	Water in fuel tank?	Flush or replace fuel tank.
	Fuel filter clogged?	Replace fuel filter.
	Stuck carburetor?	Check float mechanism.
	Spark plug is red?	Check transistor ignition unit.
	Spark plug is bluish white?	If insufficient compression, repair or replace engine. If injected air leaking, correct leak. If carburetor jets clogged, clean carburetor.
	No spark present at tip of spark plug?	Check transistor ignition unit is broken, and replace defective unit. Check if voltage cord cracked or broken and replace. Check if spark plug if fouled and replace.
	No oil?	Add oil as required.
	Oil pressure alarm lamp blinks upon starting? (if applicable)	Check automatic shutdown circuit, "oil sensor". (if applicable)
Difficult to start, fuel is available, and spark is present at the spark plug.	ON/OFF switch is shorted?	Check switch wiring, replace switch.
	Ignition coil defective?	Replace ignition coil.
	Improper spark gap, points dirty?	Set correct spark gap and clean points.
	Condenser insulation worn or short circuiting?	Replace condenser.
	Spark plug wire broken or short circuiting?	Replace defective spark plug wiring.
Difficult to start, fuel is available, spark is present and compression is normal.	Wrong fuel type?	Flush fuel system, and replace with correct type of fuel.
	Water or dust in fuel system?	Flush fuel system.
	Air cleaner dirty?	Clean or replace air cleaner.
	Choke open?	Close choke.
Difficult to start, fuel is available, spark is present and compression is low.	Suction/exhaust valve stuck or protruded?	Reseat valves.
	Piston ring and/or cylinder worn?	Replace piston rings and/or piston.
	Cylinder head and/or spark plug not tightened properly?	Torque cylinder head bolts and spark plug.
	Head gasket and/or spark plug gasket damaged?	Replace head and spark plug gaskets.
No fuel present at carburetor.	No fuel in fuel tank?	Fill with correct type of fuel.
	Fuel cock does not open properly?	Apply lubricant to loosen fuel cock lever, replace if necessary.
	Fuel filter/lines clogged?	Replace fuel filter.
	Fuel tank cap breather hole clogged?	Clean or replace fuel tank cap.
	Air in fuel line?	Bleed fuel line.

# TROUBLESHOOTING

<b>Troubleshooting (Engine) - continued</b>		
<b>Symptom</b>	<b>Possible Problem</b>	<b>Solution</b>
Weak in power, compression is proper and does not misfire.	Air cleaner dirty?	Clean or replace air cleaner.
	Improper level in carburetor?	Check float adjustment, rebuild carburetor.
	Defective spark plug?	Clean or replace spark plug.
	Improper spark plug?	Set to proper gap.
Weak in power, compression is proper but misfires.	Water in fuel system?	Flush fuel system and replace with correct type of fuel.
	Dirty spark plug?	Clean or replace spark plug.
	Ignition coil defective?	Replace ignition coil.
Engine overheats.	Spark plug heat value incorrect?	Replace with correct type of spark plug.
	Wrong type of fuel?	Replace with correct type of fuel.
	Cooling fins dirty?	Clean cooling fins.
	Intake air restricted?	Clear intake of dirt and debris. Replace air cleaner elements as necessary.
	Oil level too low or too high?	Adjust oil to proper level.
Rotational speed fluctuates.	Governor adjusted incorrectly?	Adjust governor.
	Governor spring defective?	Replace governor spring.
	Fuel flow restricted?	Check entire fuel system for leaks or clogs.
Recoil starter malfunctions. (if applicable)	Recoil mechanism clogged with dust and dirt?	Clean recoil assembly with soap and water.
	Spiral spring loose?	Replace spiral spring.
Starter malfunctions.	Loose, damaged wiring?	Ensure tight, clean connections on battery and starter.
	Battery insufficiently charged?	Recharge or replace battery.
	Starter damaged or internally shorted?	Replace starter.
Burns too much fuel.	Over-accumulation of exhaust products?	Check and clean valves. Check muffler and replace if necessary.
	Wrong spark plug?	Replace spark plug with manufacturer's suggested type.
Exhaust color is continuously "white".	Lubricating oil is wrong viscosity?	Replace lubricating oil with correct viscosity.
	Worn rings?	Replace rings.
Exhaust color is continuously "black".	Air cleaner clogged?	Clean or replace air cleaner.
	Choke valve set to incorrect position?	Adjust choke valve to correct position.
	Carburetor defective, seal on carburetor broken?	Replace carburetor or seal.
	Poor carburetor adjustment, engine runs too rich?	Adjust carburetor.
Will not start, no power with key "ON". (if applicable)	ON/OFF device not activated ON?	Turn on ON/OFF device.
	Battery disconnected or discharged?	Check cable connections. Charge or replace battery.
	Ignition switch/wiring defective?	Replace ignition switch. Check wiring.

# EXPLANATION OF CODE IN REMARKS COLUMN

The following section explains the different symbols and remarks used in the Parts section of this manual. Use the help numbers found on the back page of the manual if there are any questions.

**NOTICE**

The contents and part numbers listed in the parts section are subject to change **without notice**. Multiquip does not guarantee the availability of the parts listed.

## SAMPLE PARTS LIST

NO.	PART NO.	PART NAME	QTY.	REMARKS
1	12345	BOLT.....	1	INCLUDES ITEMS W/%
2%		WASHER, 1/4 IN.....		NOT SOLD SEPARATELY
2%	12347	WASHER, 3/8 IN....	1	MQ-45T ONLY
3	12348	HOSE .....	A/R	MAKE LOCALLY
4	12349	BEARING .....	1	S/N 2345B AND ABOVE

## NO. Column

**Unique Symbols** — All items with same unique symbol

(@, #, +, %, or >) in the number column belong to the same assembly or kit, which is indicated by a note in the “Remarks” column.

**Duplicate Item Numbers** — Duplicate numbers indicate multiple part numbers, which are in effect for the same general item, such as different size saw blade guards in use or a part that has been updated on newer versions of the same machine.

**NOTICE**

When ordering a part that has more than one item number listed, check the remarks column for help in determining the proper part to order.

## PART NO. Column

**Numbers Used** — Part numbers can be indicated by a number, a blank entry, or TBD.

TBD (To Be Determined) is generally used to show a part that has not been assigned a formal part number at the time of publication.

A blank entry generally indicates that the item is not sold separately or is not sold by Multiquip. Other entries will be clarified in the “Remarks” Column.

## QTY. Column

**Numbers Used** — Item quantity can be indicated by a number, a blank entry, or A/R.

A/R (As Required) is generally used for hoses or other parts that are sold in bulk and cut to length.

A blank entry generally indicates that the item is not sold separately. Other entries will be clarified in the “Remarks” Column.

## REMARKS Column

Some of the most common notes found in the “Remarks” Column are listed below. Other additional notes needed to describe the item can also be shown.

**Assembly/Kit** — All items on the parts list with the same unique symbol will be included when this item is purchased.

Indicated by:  
 “INCLUDES ITEMS W/(unique symbol)”

**Serial Number Break** — Used to list an effective serial number range where a particular part is used.

Indicated by:  
 “S/N XXXXX AND BELOW”  
 “S/N XXXX AND ABOVE”  
 “S/N XXXX TO S/N XXX”

**Specific Model Number Use** — Indicates that the part is used only with the specific model number or model number variant listed. It can also be used to show a part is NOT used on a specific model or model number variant.

Indicated by:  
 “XXXXX ONLY”  
 “NOT USED ON XXXX”

**“Make/Obtain Locally”** — Indicates that the part can be purchased at any hardware shop or made out of available items. Examples include battery cables, shims, and certain washers and nuts.

**“Not Sold Separately”** — Indicates that an item cannot be purchased as a separate item and is either part of an assembly/kit that can be purchased, or is not available for sale through Multiquip.



## SUGGESTED SPARE PARTS

### MC12PH CONCRETE MIXER

1 to 3 units

Qty.	P/N	Description
4.....	521458.....	V-BELT
1.....	29173-001 .....	STOPSWITCHW/GASENGINE
2.....	491010.....	LATCH SET
1.....	803270.....	O-RING
2.....	EM914288 .....	SEAL, AXLE
4.....	EM903012 .....	BEARING CLIP
4.....	EM903113 .....	BEARING CONE
2.....	3469.....	DUST CAP, AXLE

#### NOTICE

Part numbers on this Suggested Spare Parts list may supersede/replace the part numbers shown in the following parts lists.

### GX340UT2QA2/GX340UT2QAP2 ENGINES

1 to 3 units

Qty.	P/N	Description
3.....	17210ZE2515 .....	ELEMENT, AIR CLEANER
3.....	9807956846.....	SPARK PLUG, BPR6ES
1.....	28462ZV7003.....	ROPE, RECOIL STARTER
1.....	17620Z4H030.....	CAP, FUEL TANK, CHROME
1.....	17672Z4H000.....	FILTER, FUEL

# NAMEPLATE AND DECALS ASSY.

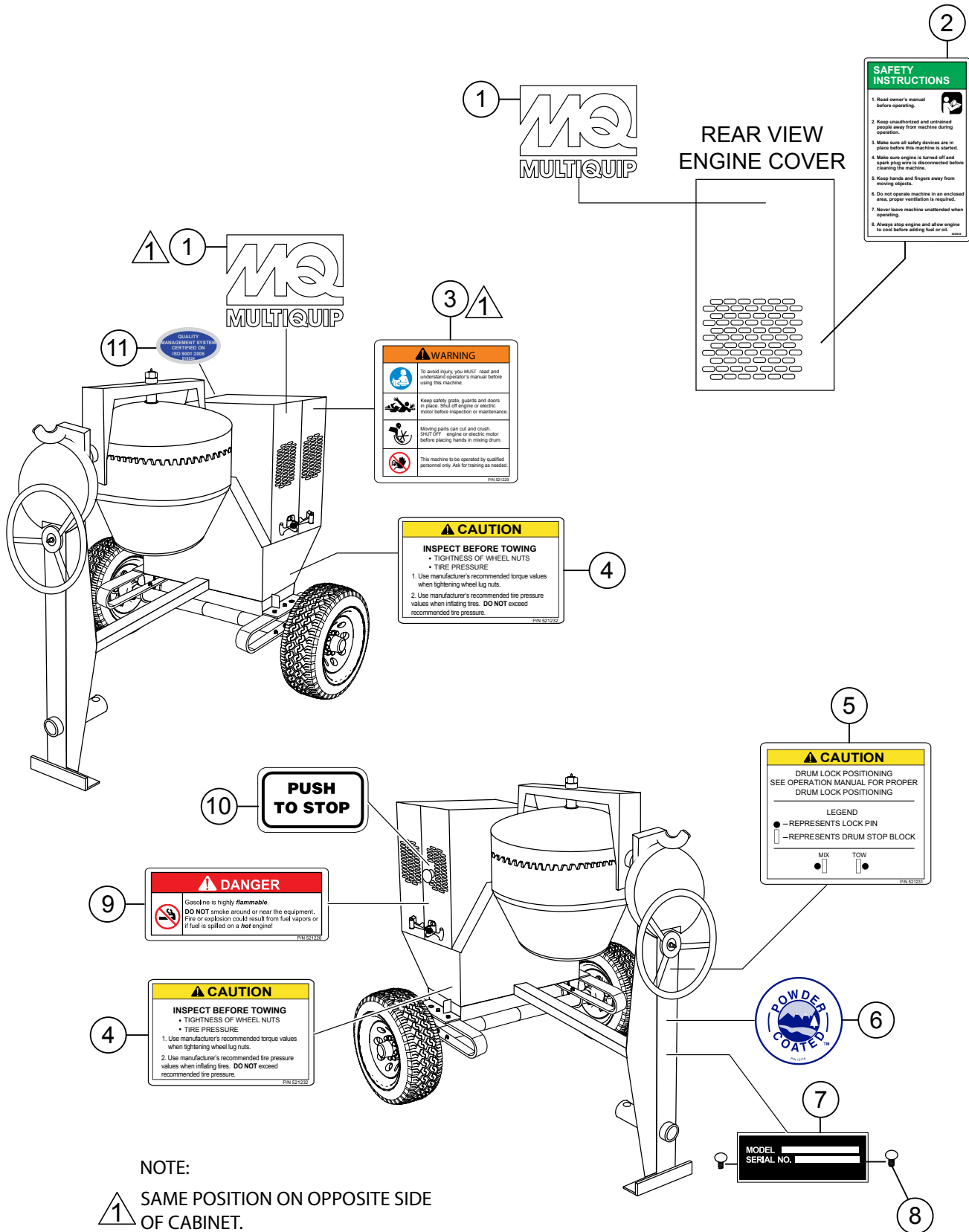

**SAFETY INSTRUCTIONS**

1. Read owner's manual before operating.
2. Keep unauthorized and untrained people away from machine during operation.
3. Make sure all safety devices are in place before this machine is started.
4. Make sure engine is turned off and spark plug wire is disconnected before cleaning the machine.
5. Keep hands and fingers away from moving objects.
6. Do not operate machine in an enclosed area, proper ventilation is required.
7. Never leave machine unattended when operating.
8. Always stop engine and allow engine to cool before adding fuel or oil.

**WARNING**

To avoid injury you MUST read and understand operator's manual before using this machine.

Keep safety gate, guards and doors in place. Shut off engine or electric motor before inspection or maintenance.

Moving parts can cut and crush. UNPLUG engine or electric motor before placing hands in mixing drum.

This machine is to be operated by qualified personnel only. Ask for training as needed.

PN 521228

**CAUTION**

**INSPECT BEFORE TOWING**

- TIGHTNESS OF WHEEL NUTS
- TIRE PRESSURE

1. Use manufacturer's recommended torque values when tightening wheel lug nuts.
2. Use manufacturer's recommended tire pressure values when inflating tires. **DO NOT** exceed recommended tire pressure.

PN 521228

**CAUTION**

**DRUM LOCK POSITIONING**  
 SEE OPERATION MANUAL FOR PROPER DRUM LOCK POSITIONING

LEGEND

- - REPRESENTS LOCK PIN
- - REPRESENTS DRUM STOP BLOCK

MIX TOW

PN 521228

**DANGER**

Gasoline is highly *flammable*. **DO NOT** smoke around or near the equipment. Fire or explosion could result from fuel vapors or if fuel is spilled on a *hot* engine!

PN 521228

**CAUTION**

**INSPECT BEFORE TOWING**

- TIRE PRESSURE

1. Use manufacturer's recommended torque values when tightening wheel lug nuts.
2. Use manufacturer's recommended tire pressure values when inflating tires. **DO NOT** exceed recommended tire pressure.

PN 521228

## NAMEPLATE AND DECALS ASSY.

<u>NO.</u>	<u>PART NO.</u>	<u>PART NAME</u>	<u>QTY.</u>	<u>REMARKS</u>
1	512910	MQ MULTIQUIP LOGO	3	
2	520935	DECAL, SAFETY INSTRUCTIONS	1	
3	521229	DECAL, WARNING READ MANUAL	2	
4	521232	DECAL, TOWING INSTRUCTIONS	2	
5	521231	DECAL, DRUM LOCK POSITION	1	
6	13118	DECAL, POWDER COATED	1	
7		NAMEPLATE .....	1	.....CONTACT MQ PARTS DEPT.
8	491757	POP RIVET	2	
9	521228	DECAL, DANGER NO SMOKING	2	
10	948630	DECAL, PUSH TO STOP	1	
11	518524	DECAL, ISO 9001:2000, EXPORT	1	

# DRUM ASSY.

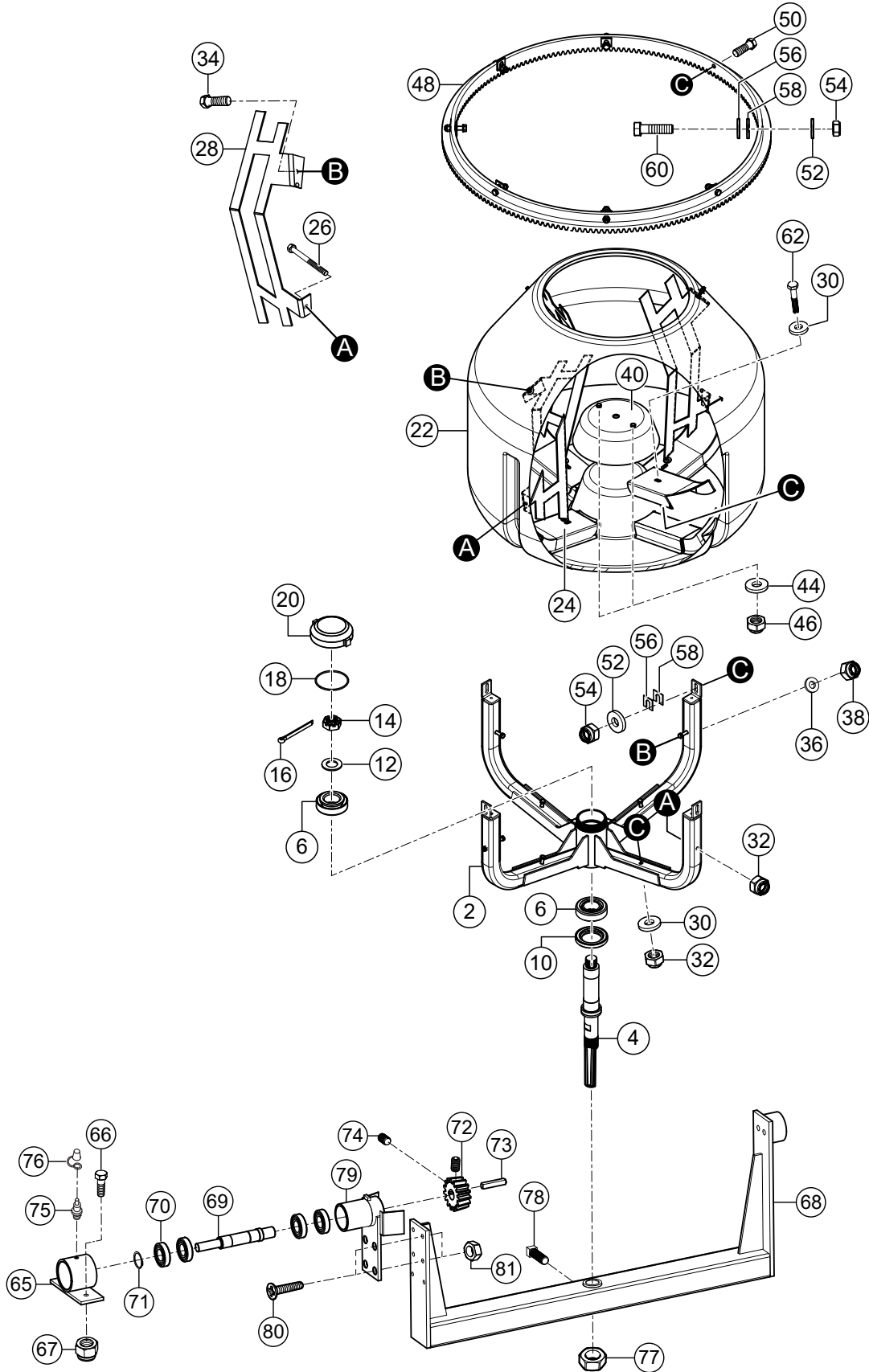

# DRUM ASSY.

<u>NO.</u>	<u>PART NO.</u>	<u>PART NAME</u>	<u>QTY.</u>	<u>REMARKS</u>
2\$	802294	SUPPORT SPIDER	1	
4\$	802803	KING PIN	1	
6\$	803269	BEARING, BARREL	2	
10\$	521573	OIL SEAL	1	
12\$	504447	WASHER	1	
14\$	516678C	NUT, KING PIN	1	
16\$	EM924006	PIN, COTTER .....	1	REPLACES P/N 491690
18\$	803270	O-RING, BARREL	1	
20\$	803267	CAP, BARREL	1	
22\$	802291	BARREL, 12 CF PLASTIC	1	
24\$	803076	GUARD, BARREL	4	
26\$	490166	BOLT, HEX 3/8" X 3-1/2", G5	4	
28\$	803181	BLADE, STEEL	4	
30\$	512193	WASHER FLAT 3/8" LARGE	4	
32\$	EM969013	NUT, HEX 3/8" NC .....	8	REPLACES P/N 492583
34\$	EM963057	BOLT, 3/8" .....	4	REPLACES P/N 492313
36\$	3019092	WASHER, FLAT 3/8" .....	4	REPLACES P/N 492598
38\$	EM969013	NUT, HEX 3/8" .....	4	REPLACES P/N 492583
40\$	804161	GUARD, BARREL CENTER	1	
44\$	3019092	WASHER, FLAT 3/8" .....	2	REPLACES P/N 492598
46\$	EM969013	NUT, HEX 3/8" .....	2	REPLACES P/N 492583
48\$	802799	RING GEAR	1	
50\$	492396	SCREW, HEX, 1/2" NC X 2" G5	4	
52\$	6109170	WASHER, FLAT 1/2" .....	8	REPLACES P/N 504322
54\$	492584	NUT, LOCK 1/2"	8	
56\$	803503	SHIM, PLASTIC #14	8	
58\$	803504	SHIM, PLASTIC #16	8	
60\$	492397	SCREW, HEX, 1/2" NC X 2-1/2" G5	4	
62\$	492388	SCREW, HEX, 3/8" NC X 3-1/4" G5	4	
65	803356	DRUM BEARING BRACKET	1	
66	EM963692	BOLT 1/2" UNC X 1-1/2" .....	2	REPLACES P/N 492394
67	492584	NUT, LOCK 1/2"	2	
68	802286	YOKE	1	
69	803396	JACKSHAFT	1	
70	803631	BEARING, JACKSHAFT	4	
71	EM926036	RING RETAINING.....	1	REPLACES P/N 490962
72	803344	PINION GEAR	1	
73	500246	KEY SQUARE	1	
74	492468	SCREW SET 5/16"	2	
75	EM916001	FITTING GREASE, 1/8" NPT.....	2	REPLACES P/N 491698
76	491008	CAP, GREASE FITTING	2	
77	07037-024	NUT, HEX 1-1/2-12 .....	1	REPLACES P/N 492579
78	492491	SCREW SET	1	
79	803635	BEARING SUPP. BRKT/GR. PROTECTOR	1	
80	EM512618	BOLT, ALLEN 1/2" X 2" .....	4	REPLACES P/N 512618
81	492589	NUT, 1/2"	4	

# FRAME ASSY.

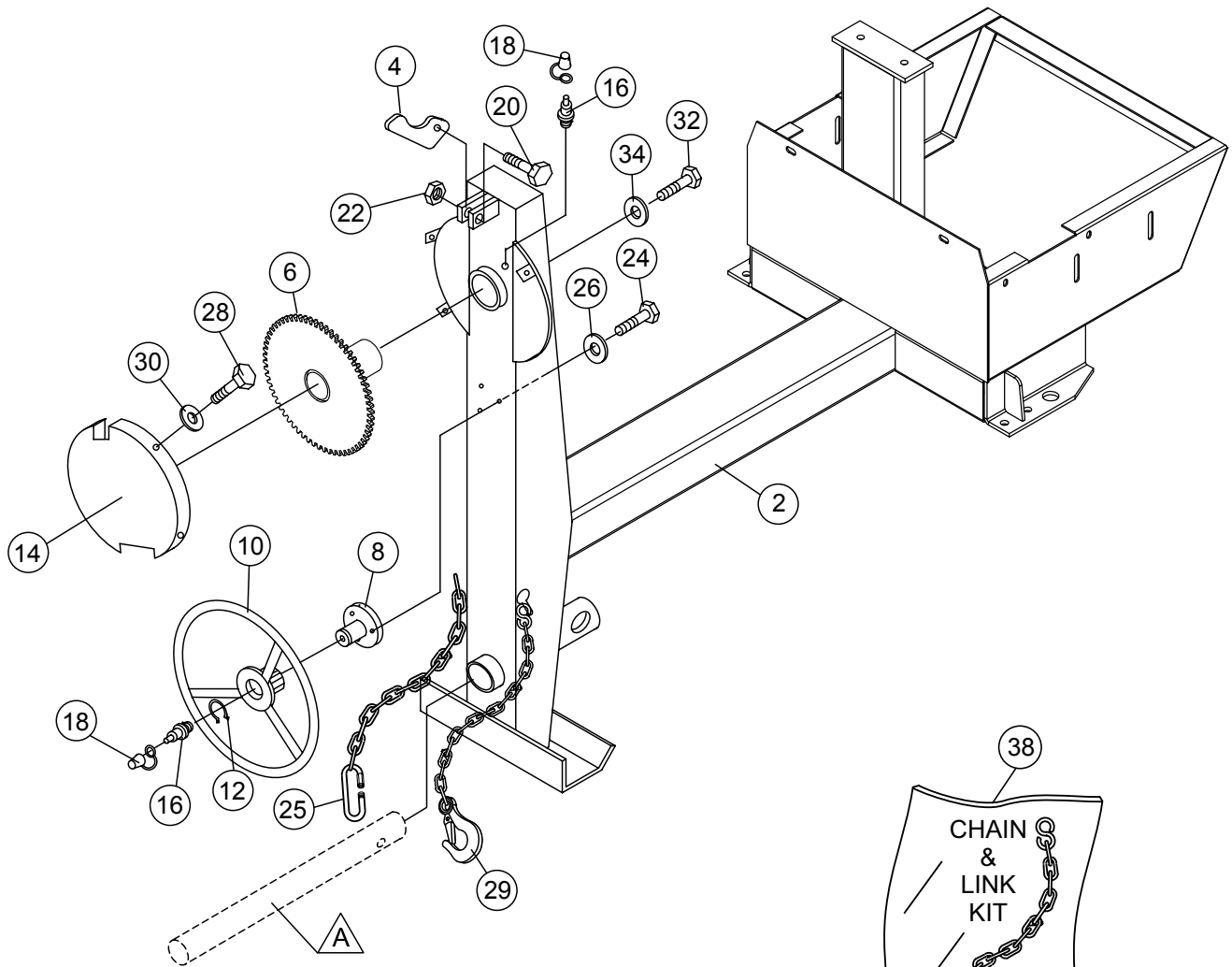

**A** OPTIONAL TOW BARS

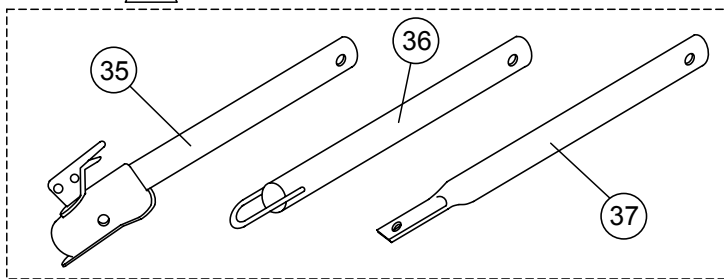

## FRAME ASSY.

<u>NO.</u>	<u>PART NO.</u>	<u>PART NAME</u>	<u>QTY.</u>	<u>REMARKS</u>
2	803346	FRAME	1	
4	490895	DUMP LATCH	1	
6	803350	DUMP GEAR	1	
8	514723	SHAFT HANDWHEEL	1	
10	803640	DUMP WHEEL	1	
12	490961	RING RETAINING	1	
14	514245	GUARD GEAR	1	
16	EM916001	FITTING GREASE .....	2.....	REPLACES P/N 491698
18	491008	FITTING PROTECTOR	2	
20	492395	BOLT, G5	1	
22	492584	NUT, LOCK 1/2"	1	
24	EM963055	BOLT, 3/8" .....	3.....	REPLACES P/N 492373
25\$	01004	CONNECTOR LINK	1	
26	0166 A	WASHER, LOCK 3/8" .....	3.....	REPLACES P/N 492624
28	492278	BOLT, HEAD ROUND 1/4" NC 3/8" G2.....	4	
29\$	516580	CLEVIS SAFETY HOOK, 1/4"	1	
30	3103160	WASHER, LOCK 3/16" .....	4.....	REPLACES P/N 492621
32	492410	BOLT, 5/8" NC X 2-1/2" G5	2	
34	EM923348	WASHER, LOCK 5/8" .....	2.....	REPLACES P/N 492627
35	HBC-1	BALL HITCH 2" .....	1.....	CONTACT UNIT SALES
36	HLC-1	LOOP HITCH .....	1.....	CONTACT UNIT SALES
37	HPC-1	PIN HITCH 1" .....	1.....	CONTACT UNIT SALES
38	13363KIT	CHAIN AND LINK KIT .....	1.....	INCLUDES ITEMS W/\$

# AXLE ASSY.

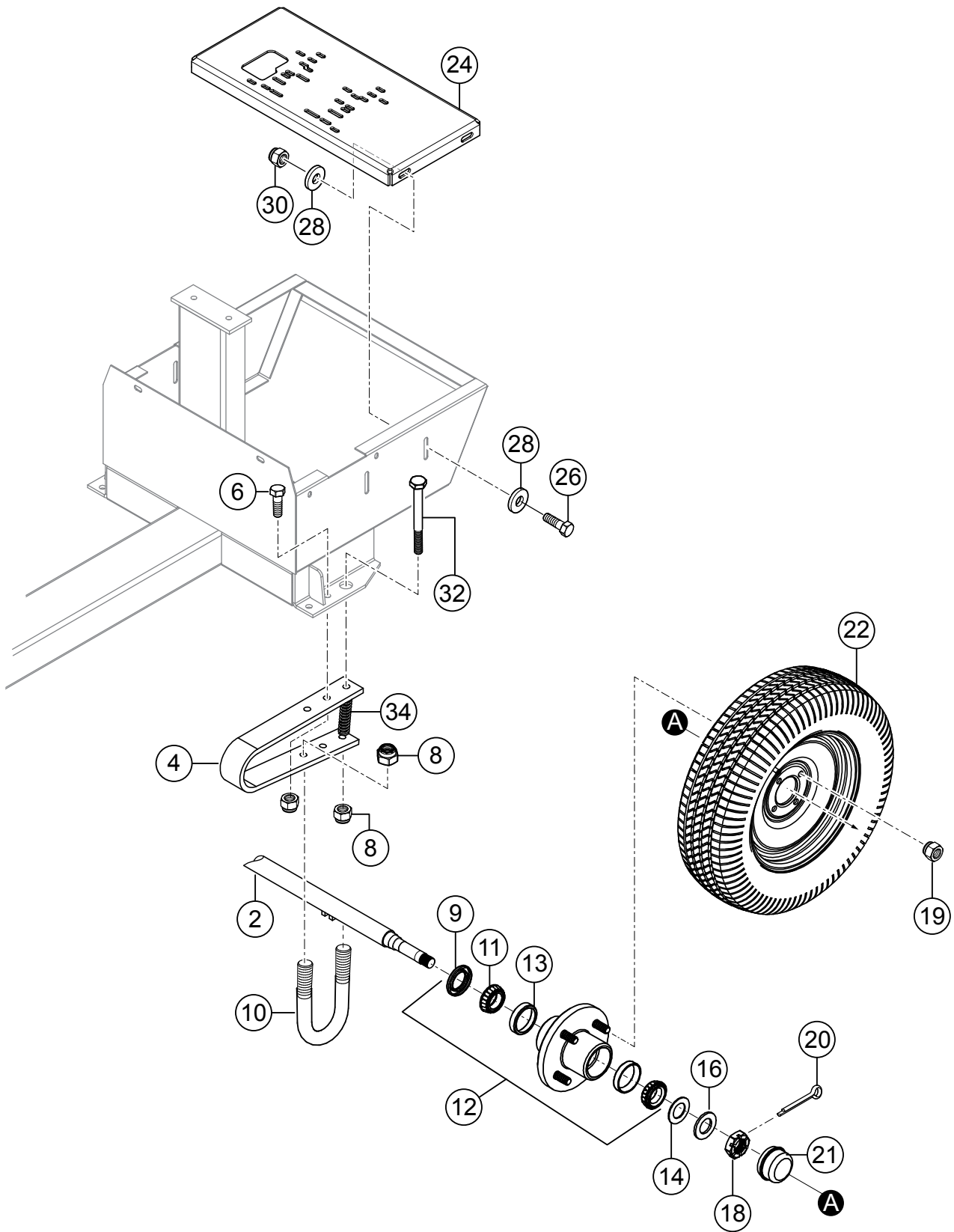



## AXLE ASSY.

<u>NO.</u>	<u>PART NO.</u>	<u>PART NAME</u>	<u>QTY.</u>	<u>REMARKS</u>
2	803393	AXLE	1	
4	3018	SPRING, LEAF	2	
6	EM963692	BOLT, 1/2" UNCX1-1/2" .....	4	REPLACES P/N 492394
8	492584	NUT, LOCK 1/2"	10	
9\$	EM914288	OIL SEAL	2	
10	3028	U-BOLT	2	
11\$	EM903113	BEARING CONE	4	
12	EM941306A	HUB ASSY., 4-BOLT .....	2	INCLUDES ITEMS W/\$
13\$	EM903012	BEARING CUP	4	
14	511159	WASHER, FLAT, .087" THICKNESS	2	
16	501299	WASHER, FLAT, .135" THICKNESS	2	
18	8164	NUT, CASTLE 1" DIA. 20.....	2	REPLACES P/N 502246
19	8115	LUG NUTS	8	
20	EM924008	PIN, COTTER 1/8"X1-1/2" .....	2	REPLACES P/N 491688
21	3469	DUST CAP	2	
22	516476	WHEEL/TIRE ASSY. 4-HOLE	2	
24	514810	BASE PLATE, ENGINE	1	
26	EM963692	BOLT, 1/2"UNCX1-1/2" .....	4	REPLACES P/N 492394
28	6109170	WASHER, FLAT 1/2".....	8	REPLACES P/N 492600
30	492584	NUT, LOCK 1/2" DIA. NC	4	
32	3043	BOLT, 1/2" X 6" G5 .....	2	REPLACES P/N 510721
34	3076	SPRING, AXLE	2	

# CABINET ASSY.

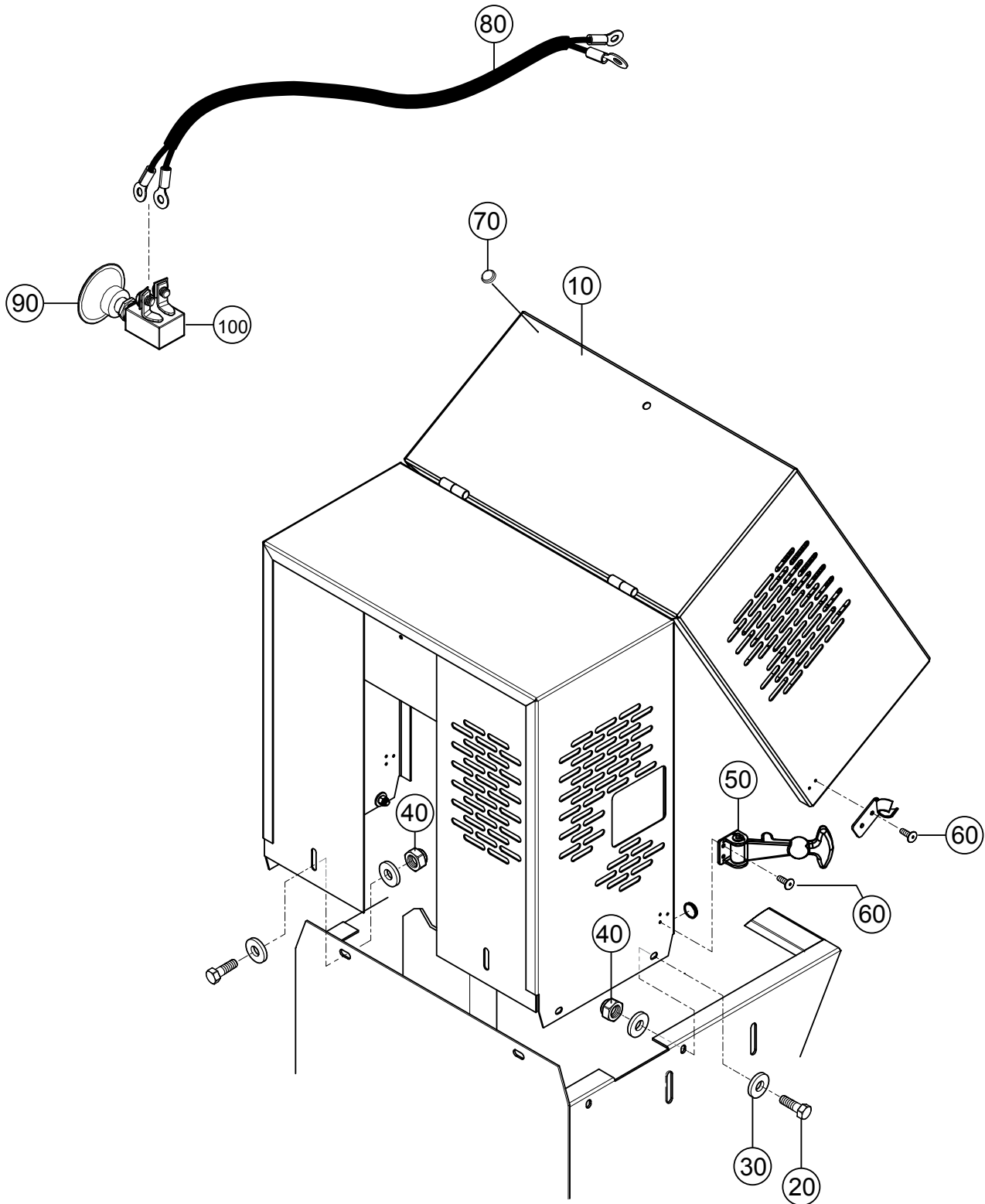

## CABINET ASSY.

---

<u>NO.</u>	<u>PART NO.</u>	<u>PART NAME</u>	<u>QTY.</u>	<u>REMARKS</u>
10	803502	ENGINE, COVER	1	
20	EM963610	CAP, SCREW.....	6.....	REPLACES P/N 492375
30	3019092	WASHER, FLAT 3/8".....	12.....	REPLACES P/N 492598
40	EM969013	NUT, HEX 3/8" NC.....	6.....	REPLACES P/N 492583
50	491010	LATCH ASSY., COMPLETE	2	
60	512881	RIVET.....	10.....	REPLACES P/N 503723
70	EM505186	CUSHION RUBBER.....	4.....	REPLACES P/N 505186
80	510573	ENGINE, CABLE HARNESS	1	
90	29174-001	BUTTON, STOP	1	
100	29173-001	SWITCH, STOP	1	

# MOUNTING PLATE ASSY.

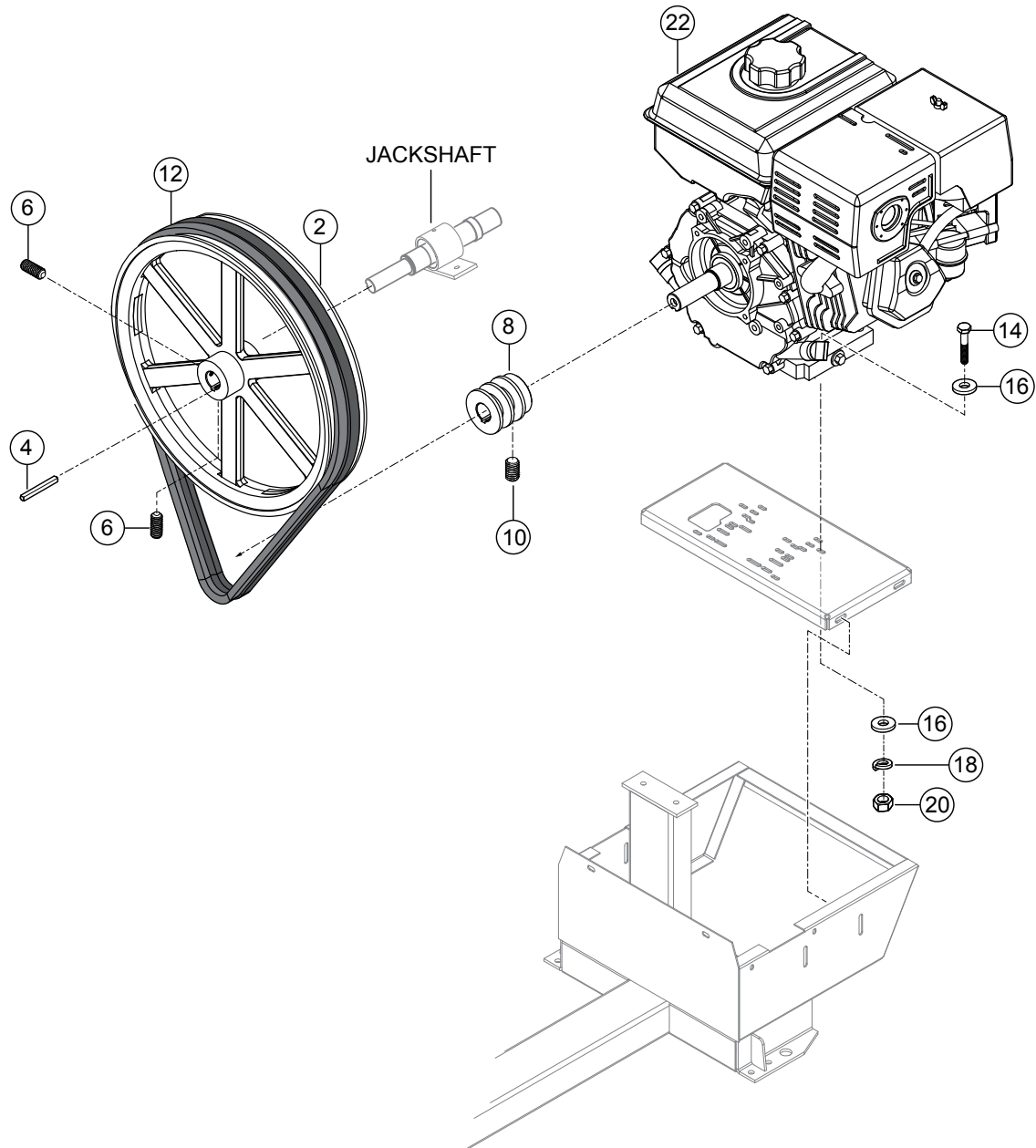

## MOUNTING PLATE ASSY.

---

<u>NO.</u>	<u>PART NO.</u>	<u>PART NAME</u>	<u>QTY.</u>	<u>REMARKS</u>
2	520232	DRIVEN PULLEY	1	
4	EM502644	KEY, JACKSHAFT	1	
6	492468	SCREW SET 5/16" .....	2.....	REPLACES P/N 492476
8	519940	PULLEY	1	
10	492468	SCREW SET 5/16"	1	
12	521458	V-BELT BX58	2	
14	492378	HHCS, G5	4	
16	3019092	WASHER FLAT 3/8" .....	8.....	REPLACES P/N 492598
18	0166 A	WASHER LOCK 3/8" DIA .....	4.....	REPLACES P/N 492624
20	1456	NUT HEX 3/8" .....	4.....	REPLACES P/N 492554
22	1388	ENG., HONDA 11HP, GX340UT2QA2/QAP2	1	

# RECOIL STARTER ASSY.

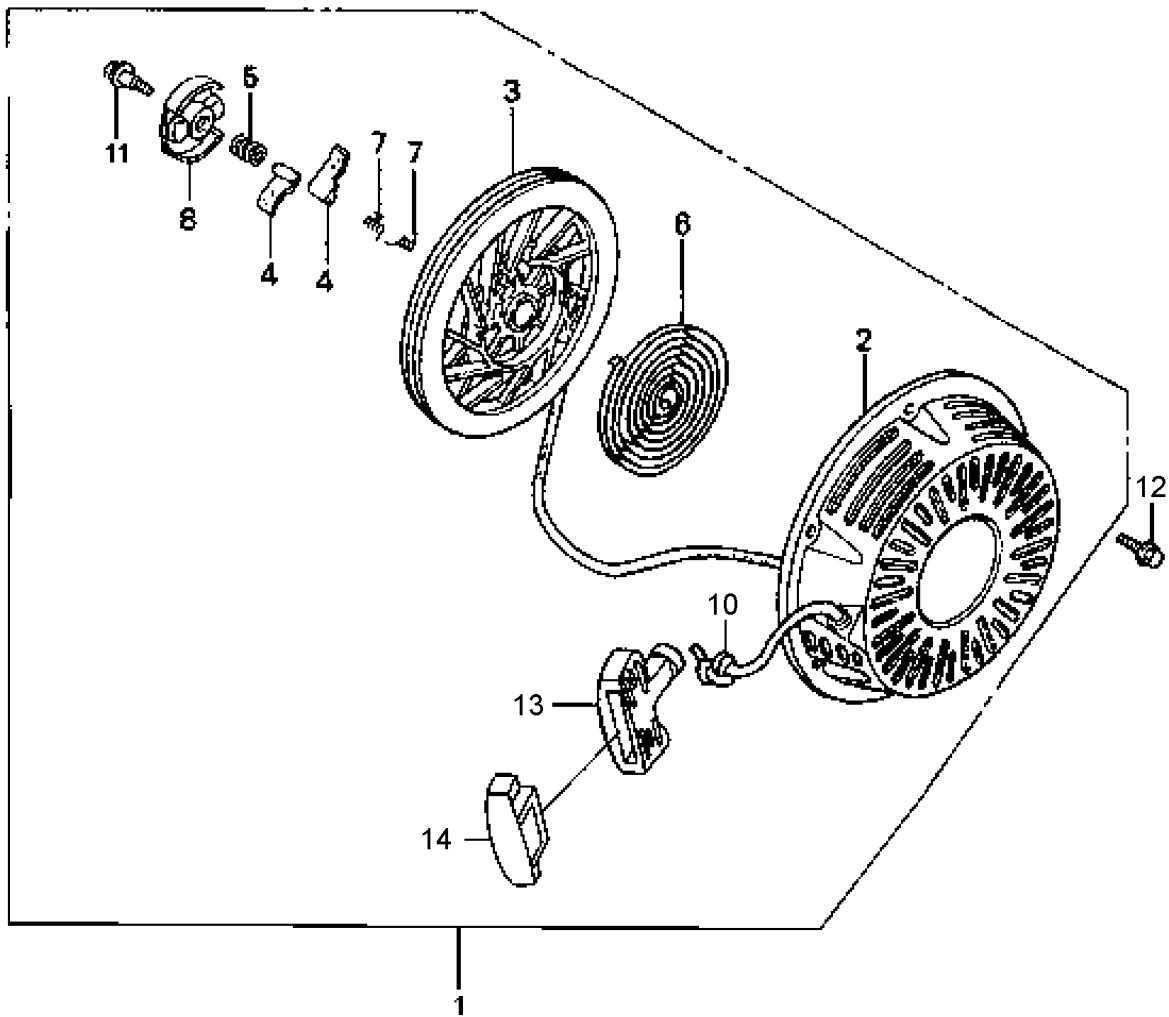

## RECOIL STARTER ASSY.

<u>NO.</u>	<u>PART NO.</u>	<u>PART NAME</u>	<u>QTY.</u>	<u>REMARKS</u>
1	28400Z5T305ZB	STARTER ASSY., RECOIL, BLK .....	1.....	INCLUDES ITEMS W/# REPLACES P/N 28400Z5T003ZB
2#	28410ZE3W01ZB	CASE COMP., RECOIL STARTE, NH1, BLK	1	
3#	28421ZE3W01	PULLEY, RECOIL STARTER	1	
4#	28422ZE2W01	RATCHET, STARTER	2	
5#	28441ZE2W01	SPRING, FRICTION	1	
6#	28442ZE2W01	SPRING, STARTER RETURN	1	
7#	28443ZE2W01	SPRING, RATCHET	2	
8#	28444ZE2W01	RETAINER, SPRING	1	
10#	28462ZV7003	ROPE, RECOIL STARTER .....	1.....	REPLACES P/N 28462ZE3W01
11#	90004ZE2W01	SCREW, CENTER	1	
12	90008ZE2003	BOLT, FLANGE, 6X10	3	
13#	28461Z5T305	GRIP, STARTER	1	
14#	28463Z5T003	GRIP, REINFORCEMENT	1	

**FAN COVER ASSY.**

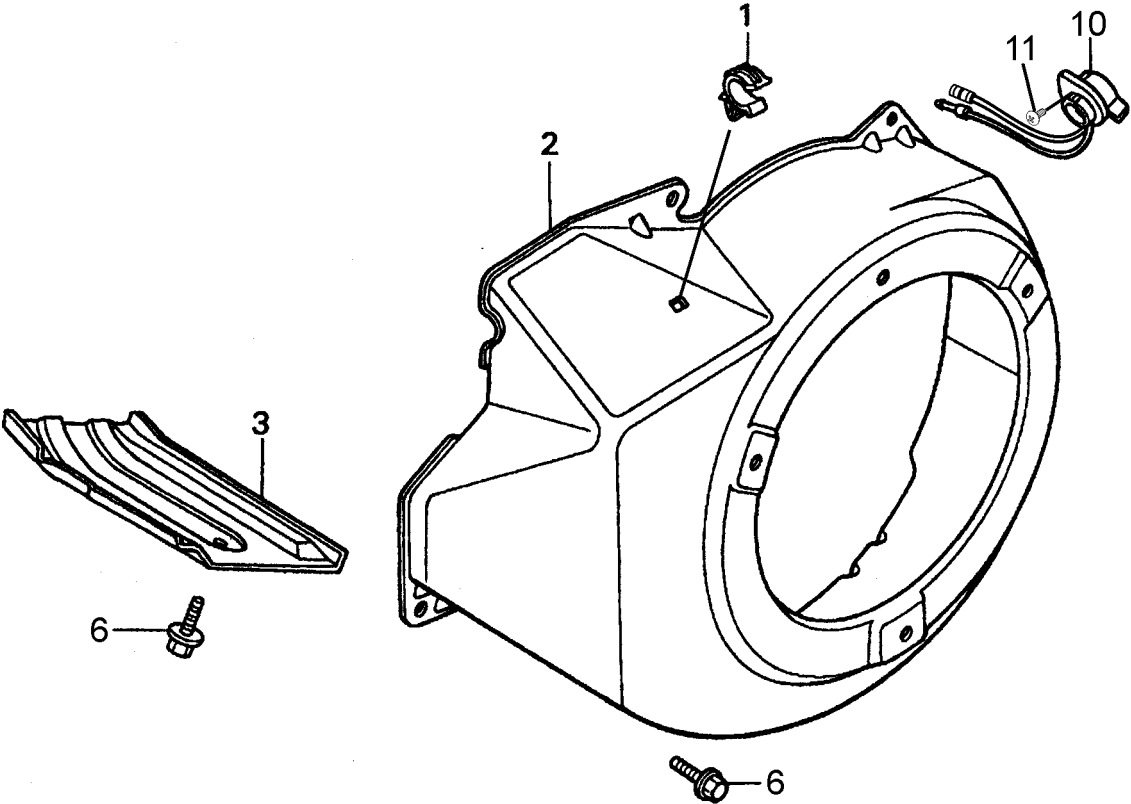



## FAN COVER ASSY.

---

<u>NO.</u>	<u>PART NO.</u>	<u>PART NAME</u>	<u>QTY.</u>	<u>REMARKS</u>
1	16731ZE2003	CLIP, TUBE	1	
2	19610Z5T000ZB	COVER COMP., FAN, NH1, BLACK	1	
3	19631Z5T000	SHROUD	1	
6	90013883000	BOLT, FLANGE, 6X12	6	
10	35120Z5T003	SWITCH ASSY., ENGINE STOP	1	
11	90004Z5T000	SCREW, TAPPING, 3X6	2	

# CARBURETOR ASSY.

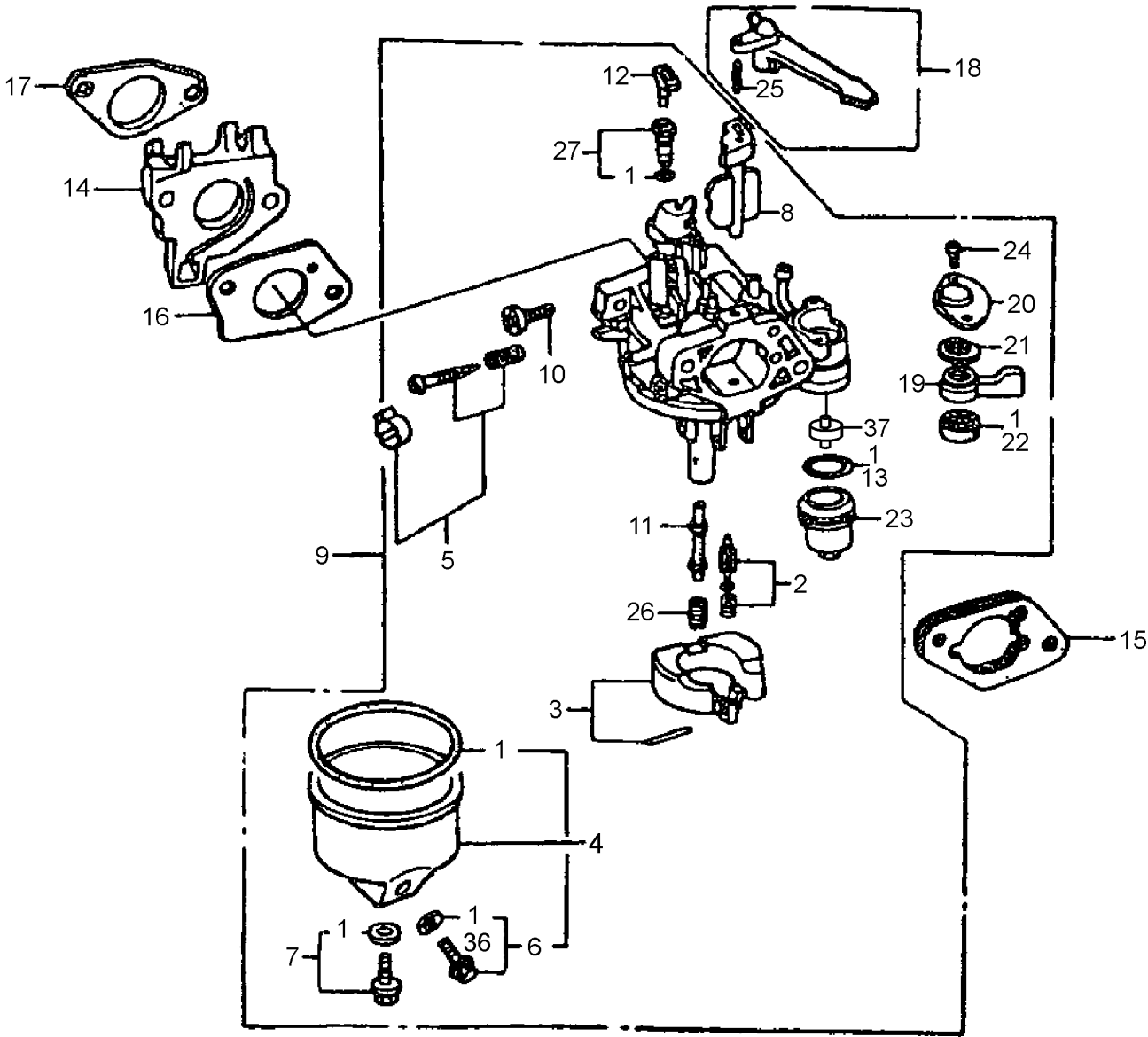

**NOTICE**  
 Gasket Set, item 1 included with items 6, 7, 13, 22, 27 and 36.

## CARBURETOR ASSY.

<u>NO.</u>	<u>PART NO.</u>	<u>PART NAME</u>	<u>QTY.</u>	<u>REMARKS</u>
1#	16010ZE2812	GASKET SET	1	
2#	16011ZA0931	VALVE SET, FLOAT	1	
3#	16013ZA0931	FLOAT SET	1	
4#	16015Z5T901	CHAMBER SET, FLOAT	1	
5#	16016ZH7W01	SCREW SET, PILOT	1	
6#	16024Z5T901	SCREW SET, DRAIN	1	
7#	16028Z5T901	SCREW SET	1	
8#	16044ZE3811	CHOKE SET	1	
9	16100Z8T911	CARBURETOR ASSY. (BE80M A) .....	1	INCLUDES ITEMS WITH #
10#	16124ZE0005	SCREW, THROTTLE STOP	1	
11#	16166Z8T911	NOZZLE, MAIN	1	
12#	16172ZE3W10	COLLAR, SETTING	1	
13	16955283000	PACKING, FUEL STRAINER CUP .....	1	REPLACES P/N 16173001004
14	16211Z8T000	INSULATOR, CARBURETOR	1	
15	16220ZA0702	SPACER COMP., CARBURETOR	1	
16	16221Z8T000	PACKING, CARBURETOR	1	
17	16212Z5T000	PACKING, CARBURETOR INSULATOR	2	
18	16610ZE1000	LEVER COMP., CHOKE (STD.) .....	1	INCLUDES ITEMS W/\$
19#	16953ZE1812	LEVER, COCK	1	
20#	16954ZE1812	PLATE, LEVER SETTING	1	
21#	16956ZE1811	SPRING, COCK LEVER	1	
22#	16957ZE1812	PACKING, FUEL COCK	1	
23#	16967ZE0811	CUP, FUEL STRAINER	1	
24#	93500030060H	SCREW, PAN, 3X6 .....	2	REPLACES P/N 93500030061H
25\$	9430520122	PIN, SPRING, 2X12	1	
26#	99101ZH80900	JET, MAIN, #90	1	
26#	99101ZH80950	JET, MAIN, #95	1	
26#	99101ZH80980	JET, MAIN, #98	1	
27#	99204ZE00380	JET SET, PILOT, #38	1	
36#	16141Z0S003	WASHER, FLAT .....	1	GX340UT2QAP2
37#	16959Z5T901	FILTER, CUP	1	

# AIR CLEANER ASSY.

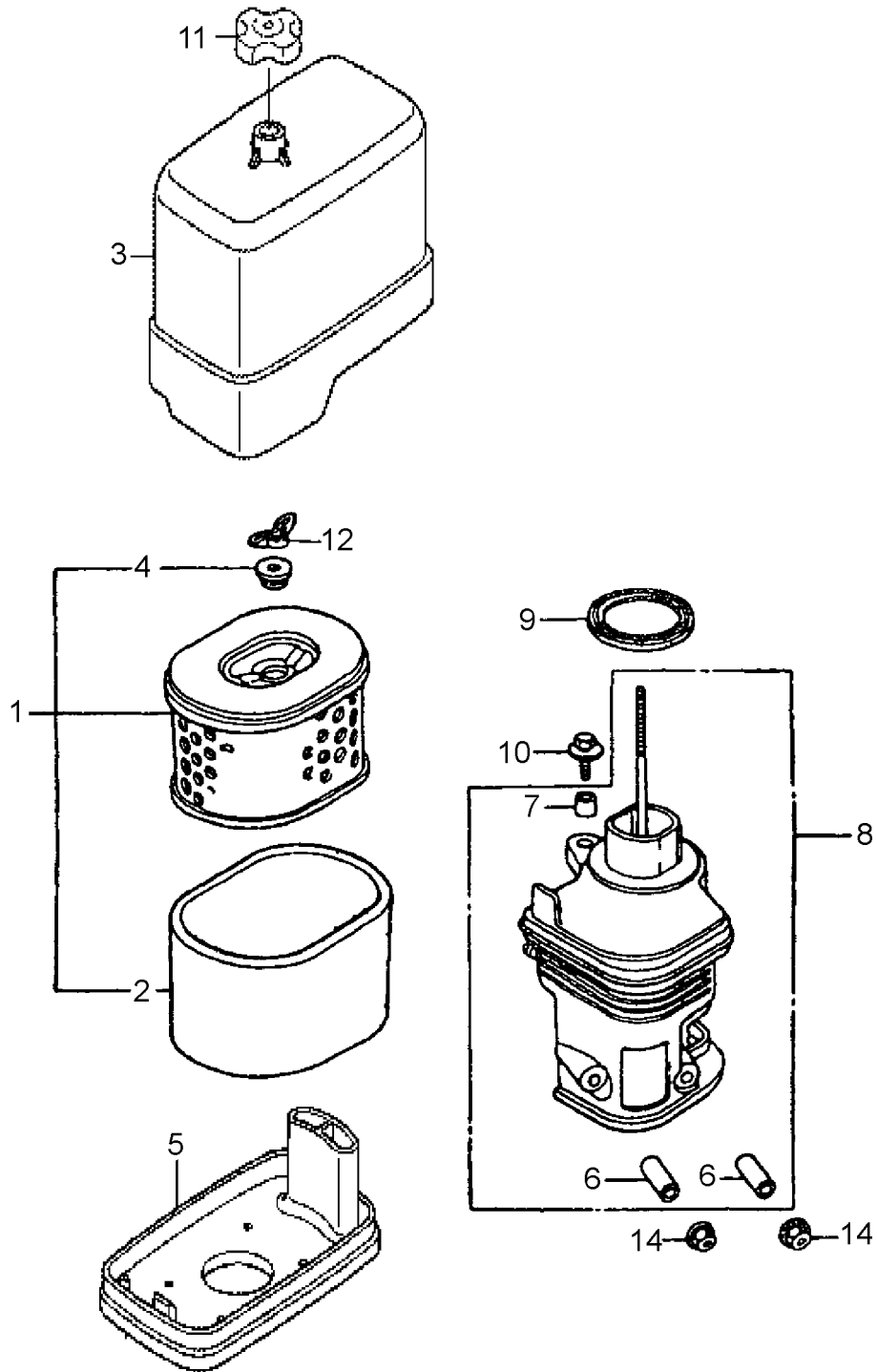

## AIR CLEANER ASSY.

---

<u>NO.</u>	<u>PART NO.</u>	<u>PART NAME</u>	<u>QTY.</u>	<u>REMARKS</u>
1	17210ZE2515	ELEMENT, AIR CLEANER .....	1.....	INCLUDES ITEMS W/#
2#	17218ZE3505	FILTER, OUTER .....	1.....	REPLACES P/N 17218ZE3000
3	17231Z5T000	COVER, AIR CLEANER CASE	1	
4#	17232891000	GROMMET, AIR CLEANER	1	
5	17235Z5T000	NOSE, SILENCER	1	
6%	17238ZE2310	COLLAR, AIR CLEANER	2	
7%	17239ZE1000	COLLAR B, AIR CLEANER	1	
8	17410Z5T000	ELBOW COMP., AIR CLEANER .....	1.....	INCLUDES ITEMS W/%
9	17417Z5T000	PACKING, AIR CLEANER CASE	1	
10	90009Z1C000	BOLT-WASHER, 6X22	1	
11	90202Z2E000	NUT, AIR CLEANER COVER	1	
12	90325044000	NUT, TOOL BOX SETTING	1	
13	9405006000	NUT, FLANGE, 6MM	2	

# MUFFLER ASSY.

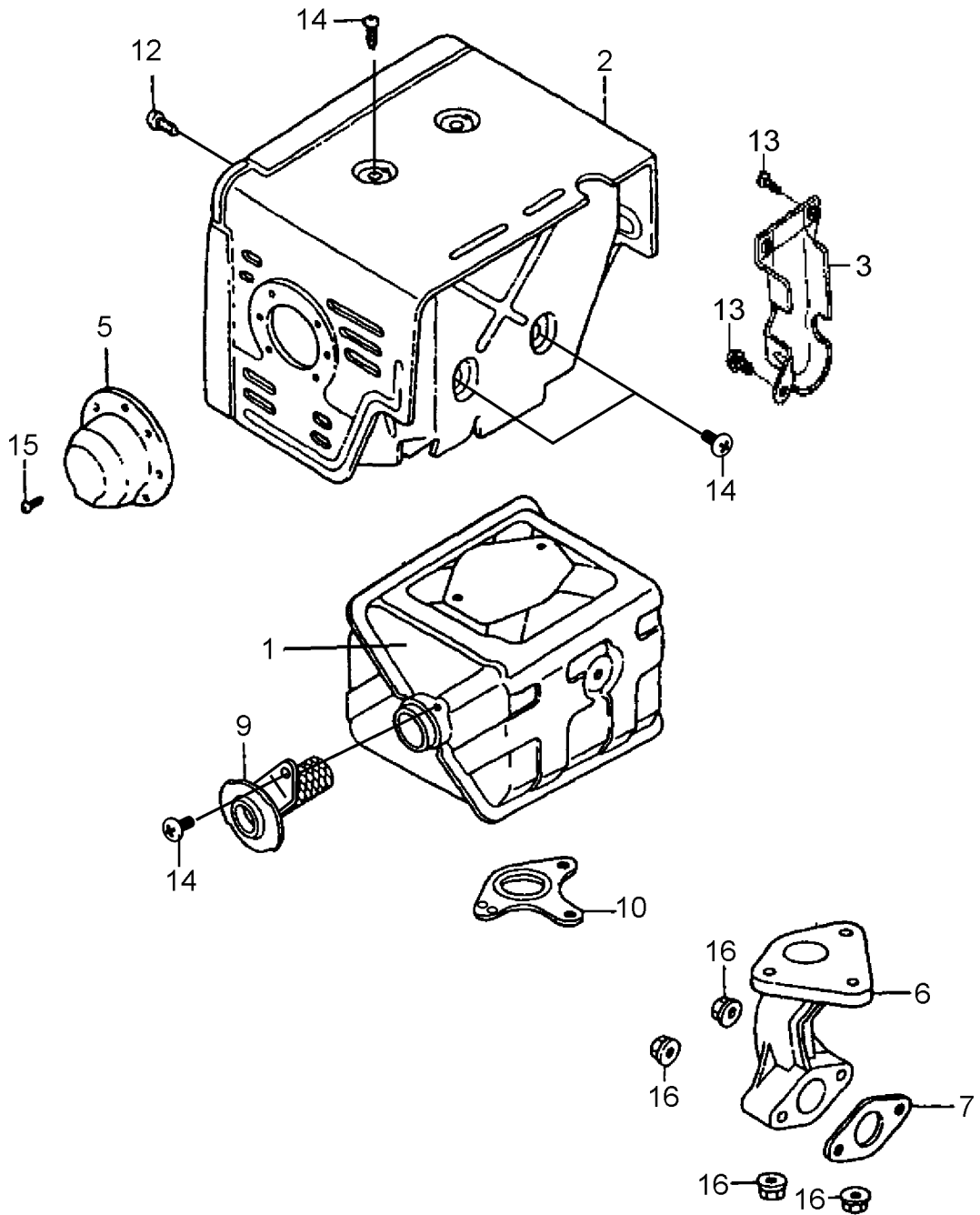

## MUFFLER ASSY.

---

<u>NO.</u>	<u>PART NO.</u>	<u>PART NAME</u>	<u>QTY.</u>	<u>REMARKS</u>
1	18310Z5T000	MUFFLER COMP.	1	
2	18320Z5T000	PROTECTOR COMP., MUFFLER	1	
3	18205Z5T000	PROTECTOR, EX. PIPE	1	
5	18331ZE3811	CAP, MUFFLER	1	
6	18331Z5T000	PIPE, EX.	1	
7	18333ZF6W01	GASKET, EX. PIPE	1	
9	18350Z5T800	ARRESTER COMP., SPARK	1	
10	18381ZE2W10	GASKET, MUFFLER (ARRESTER)	1	
12	90006ZE2000	SCREW, TAPPING, 6X10	1	
13	90013883000	BOLT, FLANGE, 6X12	1	
14	90050ZE1000	SCREW, TAPPING, 5X8	8	
15	90055ZE1000	SCREW, TAPPING, 4X6	3	
16	9405008000	NUT, FLANGE, 8MM	5	

# FUEL TANK ASSY.

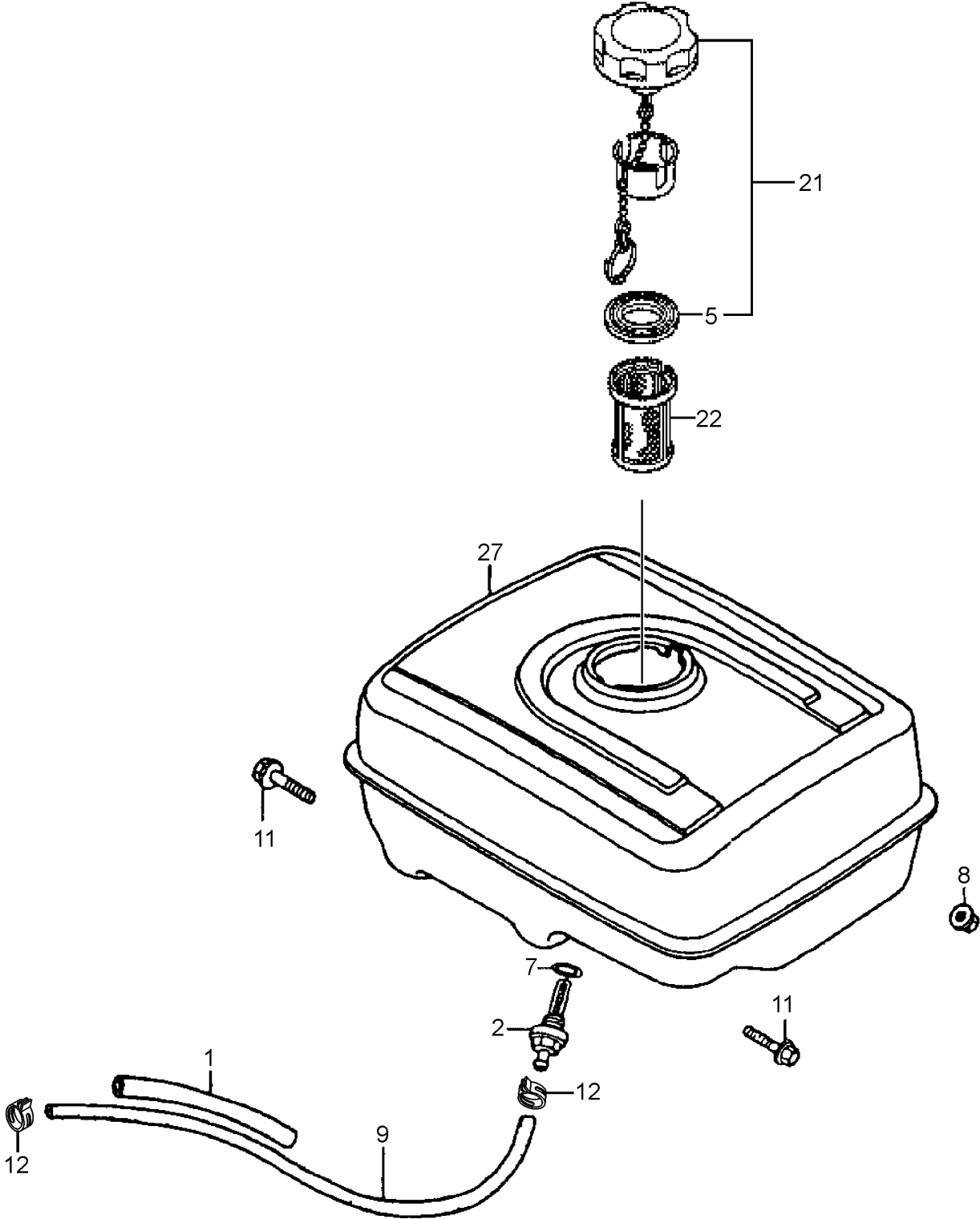



## FUEL TANK ASSY.

---

<u>NO.</u>	<u>PART NO.</u>	<u>PART NAME</u>	<u>QTY.</u>	<u>REMARKS</u>
1	16854ZH8000	RUBBER, SUPPORTER (107 MM)	1	
2	16955ZE1010	JOINT, FUEL TANK	1	
5 #	17631Z0T801	PACKING, FUEL FILL. CAP	1	
7	91353671003	O-RING, 14MM .....	1	REPLACES P/N 91353671004
8	9405008000	NUT, FLANGE, 8MM	2	
9	91424Z5T003	TUBE, FUEL, 4.5X235	1	
11	957010802500	BOLT, FLANGE, 8X25	2	
12	950024080008	CLAMP, TUBE	2	
21	17620Z4H030	CAP COMP., FUEL FILL. (CHROME PLT.) .....	1	INCLUDES ITEM W/#
22	17672Z4H000	FILTER, FUEL	1	
27	17510Z5T000ZA	TANK COMP., FUEL, WHITE	1	

**FLYWHEEL ASSY.**

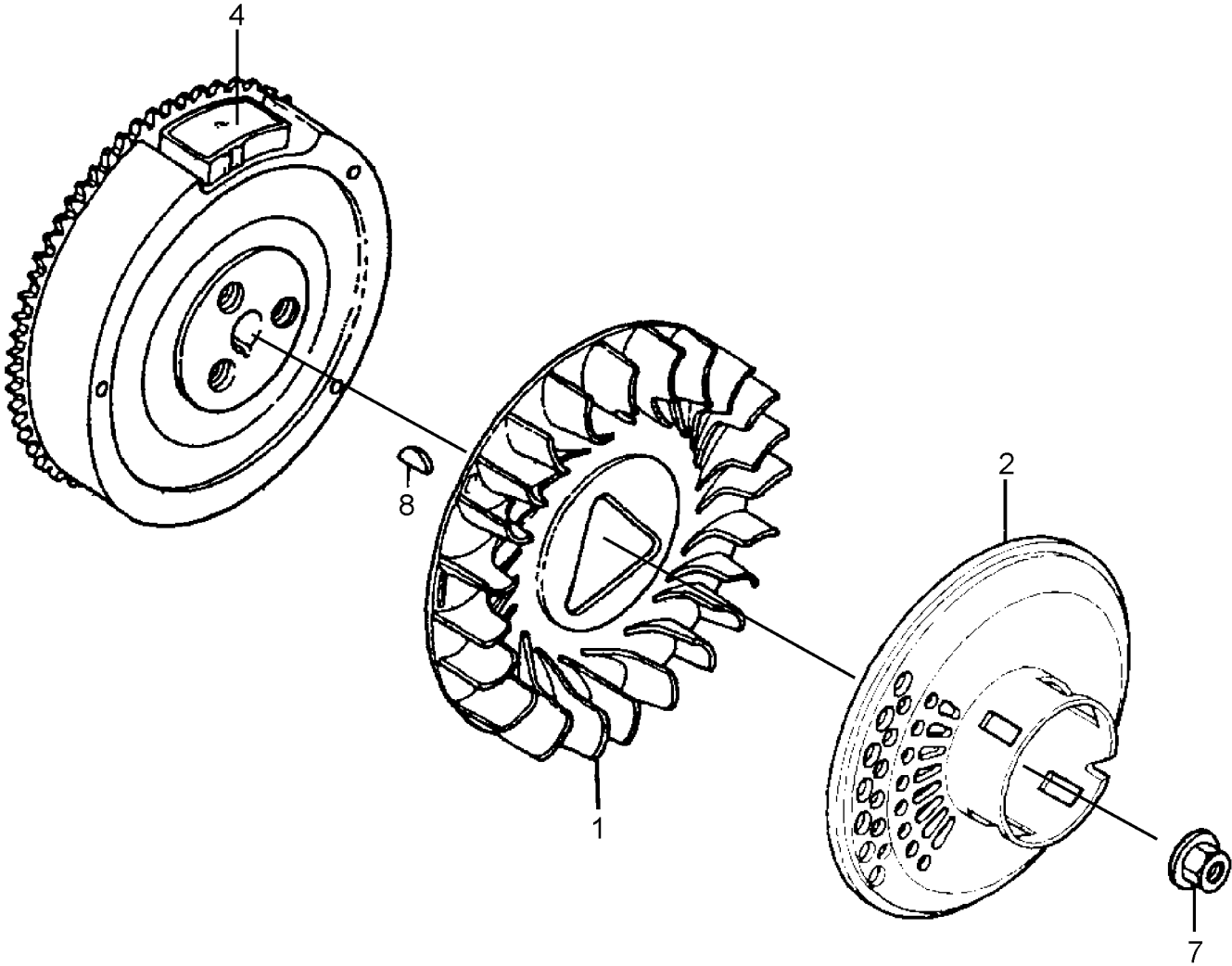

## FLYWHEEL ASSY.

---

<u>NO.</u>	<u>PART NO.</u>	<u>PART NAME</u>	<u>QTY.</u>	<u>REMARKS</u>
1	19511ZE3000	FAN, COOLING	1	
2	28450ZE3W11	PULLEY COMP., STARTER	1	
4	31110Z5T000	FLYWHEEL COMP.	1	
7	90201ZE3790	NUT, SPECIAL, 16MM	1	
8	90741ZE2000	KEY, SPECIAL WOODRUFF, 25X18	1	

# CYLINDER HEAD ASSY.

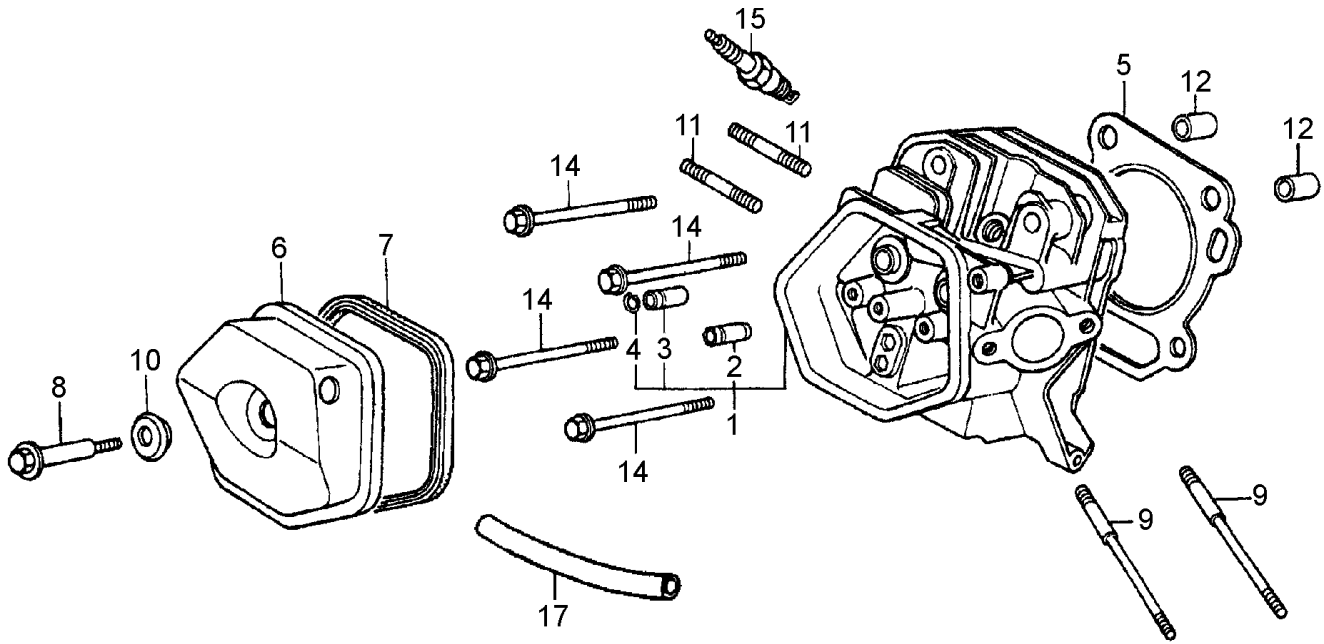

## CYLINDER HEAD ASSY.

<u>NO.</u>	<u>PART NO.</u>	<u>PART NAME</u>	<u>QTY.</u>	<u>REMARKS</u>
1	12210Z5T406	HEAD COMP., CYLINDER .....	1.....	INCLUDES ITEMS W/#
2#	12204ZE2306	GUIDE, IN. VALVE (O.S.)	1	
3#	12205ZE2305	GUIDE, EX. VALVE (O.S.)	1	
4#	12216ZE2300	CLIP, VALVE GUIDE	1	
5	12251Z5T003	GASKET, CYLINDER HEAD	1	
6	12310ZE2020	COVER COMP., HEAD	1	
7	12391ZE2020	PACKING, HEAD COVER	1	
8	90014Z5T000	BOLT, HEAD COVER	1	
9	90042ZE2000	BOLT, STUD, 8X123	2	
10	90441ZE2010	WASHER COMP., HEAD COVER	1	
11	92900080320E	BOLT, STUD, 8X32	2	
12	9430112200	DOWEL PIN, 12X20	2	
14	957011008000	BOLT, FLANGE, 10X80	4	
15	9807956846	PLUG, SPARK (BPR5ES) .....	1.....	REPLACES P/N 9807956876
15	9807955855	PLUG, SPARK (W16EPR-U)	1	
17	12357Z5T020	TUBE, BREATHER	1	

# IGNITION COIL ASSY.

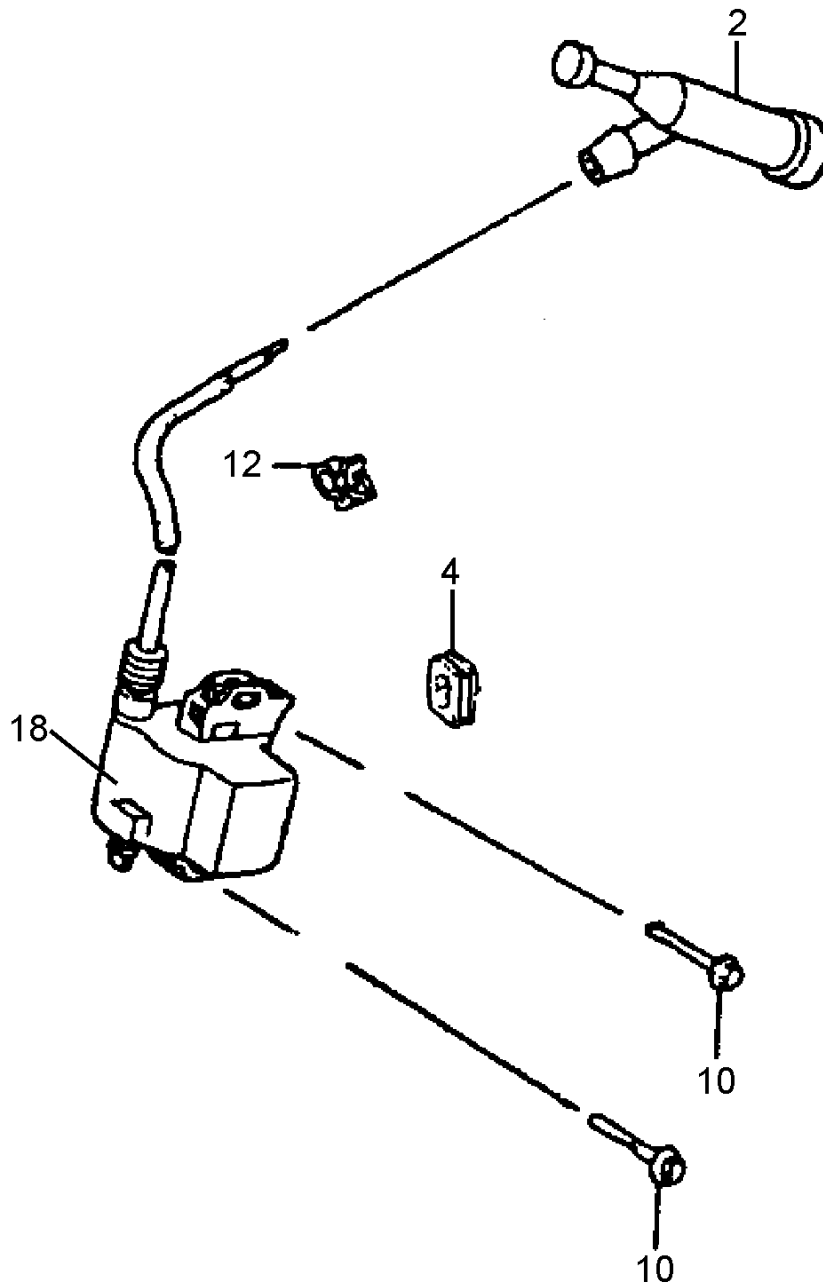

## IGNITION COIL ASSY.

---

<u>NO.</u>	<u>PART NO.</u>	<u>PART NAME</u>	<u>QTY.</u>	<u>REMARKS</u>
2	30700Z1C811	CAP ASSY., NOISE SUPPRESSOR	1	
4	31512ZE2000	GROMMET, CORD	1	
10	90015883000	BOLT, FLANGE, 6X28	2	
12	90684ZA0601	CLIP, HARNESS	1	
18	30500Z5T003	COIL ASSY., IGNITION	1	

# CONTROL ASSY.

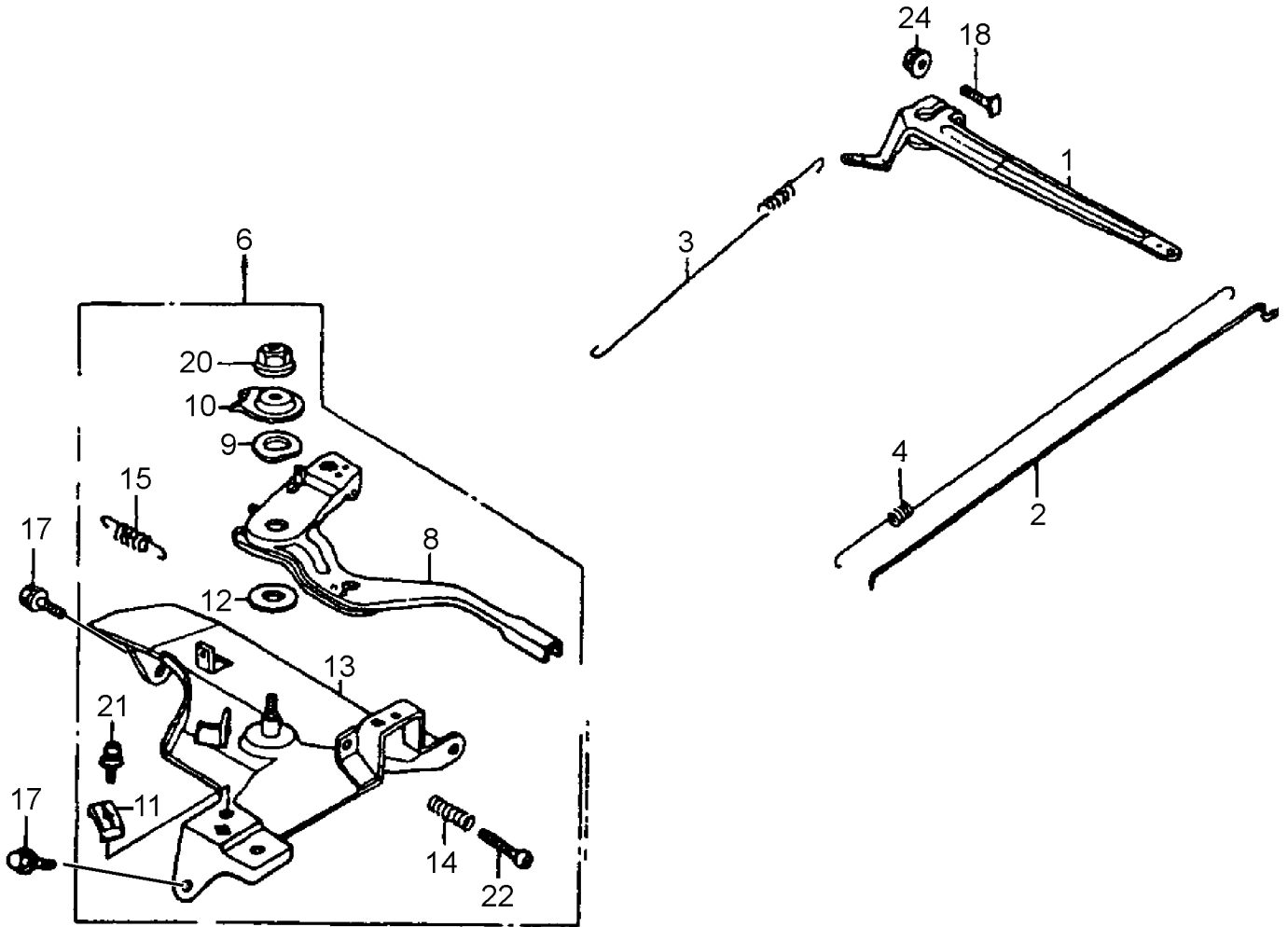



## CONTROL ASSY.

<u>NO.</u>	<u>PART NO.</u>	<u>PART NAME</u>	<u>QTY.</u>	<u>REMARKS</u>
1	16551ZE3000	ARM, GOVERNOR	1	
2	16555ZE3000	ROD, GOVERNOR	1	
3	16561ZE3000	SPRING, GOVERNOR (L=145.0MM)	1	
4	16562ZE3000	SPRING, THROTTLE RETURN	1	
6	16500Z5T810	CONTROL ASSY. (REMOTE) .....	1	INCLUDES ITEMS W/#
8#	16571ZE2W00	LEVER, CONTROL	1	
9#	16574ZE1000	SPRING, LEVER	1	
10#	16575ZE2W00	WASHER, CONTROL LEVER	1	
11#	16576891000	HOLDER, CABLE	1	
12#	16578ZE1000	SPACER, CONTROL LEVER	1	
13#	16580Z5T000	BASE COMP., CONTROL	1	
14#	16584883300	SPRING, CONTROL ADJUSTING	1	
15#	16592883310	SPRING, CABLE RETURN	1	
17	90013883000	BOLT, FLANGE, 6X12	2	
18	90015Z5T000	BOLT, GOVERNOR ARM	1	
20#	90114SA0000	NUT, SELFLOCK, 6MM	1	
21#	0202005T125	SCREW, PAN, 5X16 .....	1	REPLACES P/N 93500050160A
22#	93500050280A	SCREW, PAN, 5X32	1	
24	9405006000	NUT, FLANGE, 6MM	1	

# CYLINDER BARREL ASSY.

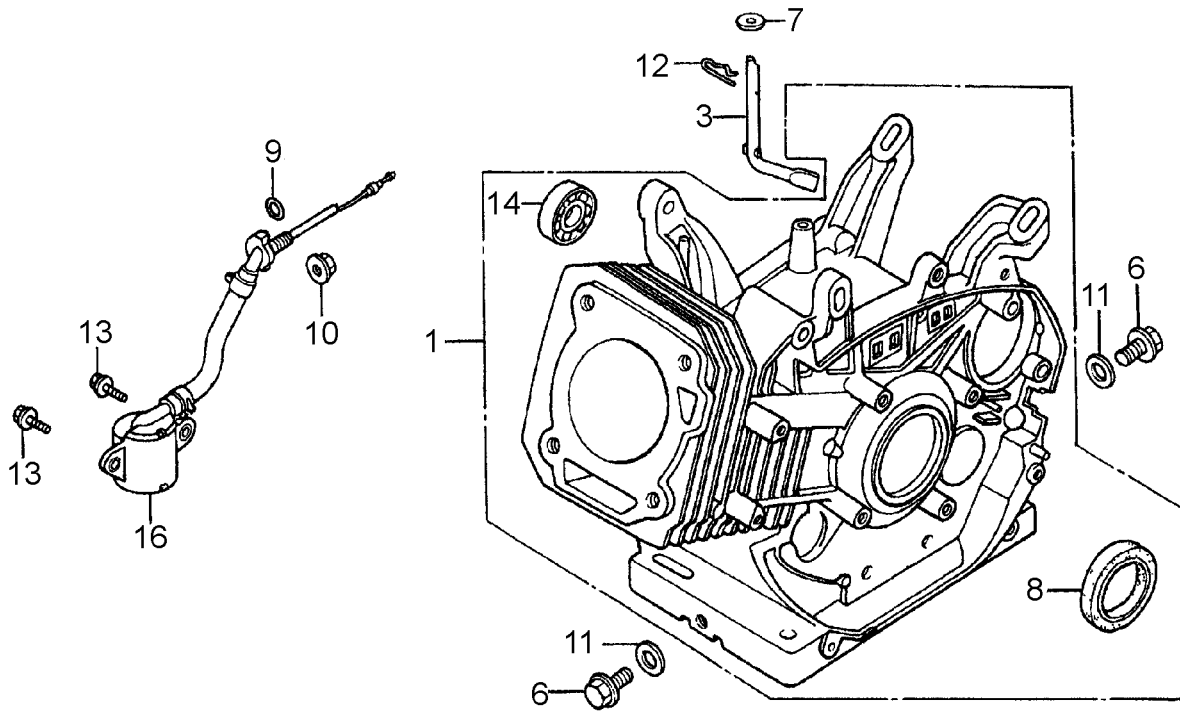

## CYLINDER BARREL ASSY.

---

<u>NO.</u>	<u>PART NO.</u>	<u>PART NAME</u>	<u>QTY.</u>	<u>REMARKS</u>
1	12000Z5T407	BARREL ASSY., CYLINDER .....	1.....	INCLUDES ITEMS W/#
3	16541ZE3010	SHAFT, GOVERNOR ARM	1	
6	90131896650	BOLT, DRAIN PLUG, 12X15 .....	2.....	REPLACES P/N 90131883000
7	90446KE1000	WASHER, 8.2X17X0.8	1	
8#	91201Z1C003	OIL SEAL, 35X52X8	1	
9	91353671003	ORING, 14MM .....	1.....	REPLACES P/N 91353671004
10	9405010000	NUT, FLANGE, 10MM	1	
11	031112230	WASHER, DRAIN PLUG, 12MM .....	2.....	REPLACES P/N 9410912000
12	9425110000	PIN, LOCK, 10MM	1	
13	957010601200	BOLT, FLANGE, 6X12	2	
14#	96100-6202000	BEARING, RADIAL BALL, 6202	1	
16	35480ZF6003	SWITCH ASSY., OIL LEVEL	1	

# CRANKCASE COVER ASSY.

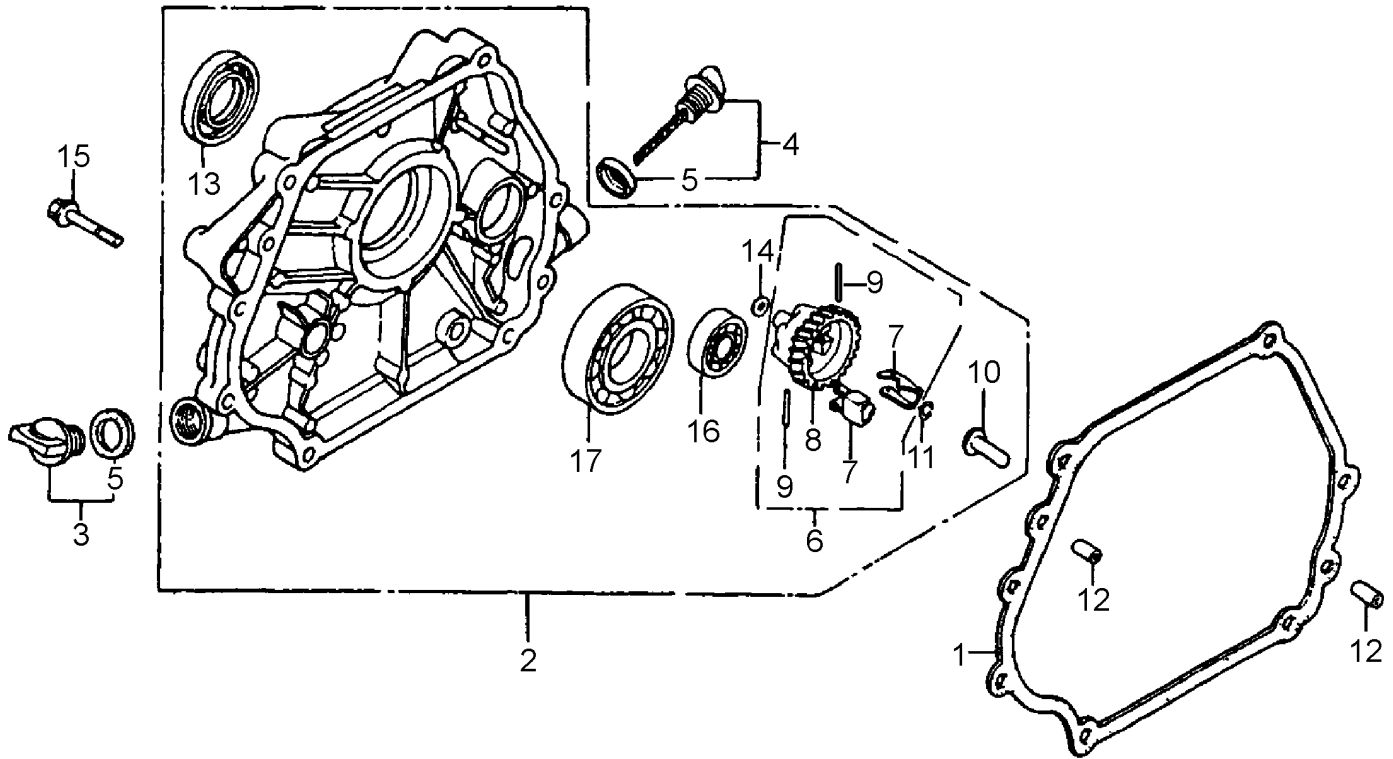

## CRANKCASE COVER ASSY.

<u>NO.</u>	<u>PART NO.</u>	<u>PART NAME</u>	<u>QTY.</u>	<u>REMARKS</u>
1	11381Z5T000	PACKING, CASE COVER	1	
2	11300Z1C600	COVER ASSY., CRANKCASE .....	1.....	INCLUDES ITEMS W/#
3	15600Z0T820	CAP ASSY., OIL FILLER .....	1.....	INCLUDES ITEMS W/%
4	15600Z1C000	CAP ASSY., OIL FILLER .....	1.....	INCLUDES ITEMS W/\$
5%\$	15625Z0T800	PACKING, OIL FILLER CAP	2	
6#	16510ZE3000	GOVERNOR ASSY. ....	1.....	INCLUDES ITEMS W/@
7#@	16511ZE8000	WEIGHT, GOVERNOR	2	
8#@	16512ZE3000	HOLDER, GOVERNOR WEIGHT	1	
9#@	16513ZE2000	PIN, GOVERNOR WEIGHT	2	
10#	16531Z0A000	SLIDER, GOVERNOR	1	
11#	90602ZE1000	CLIP, GOVERNOR HOLDER	1	
12	90701HC4000	DOWEL PIN, 8X12	2	
13#	91201Z1C003	OIL SEAL, 35X52X8	1	
14#	58176	WASHER, FLAT 6MM .....	1.....	REPLACES P/N 9410106800
15	957010804000	BOLT, FLANGE, 8X40	7	
16#	961006202000	BEARING, RADIAL BALL, 6202	1	
17#	961006207000	BEARING, RADIAL BALL, 6206	1	

**CRANKSHAFT ASSY.**

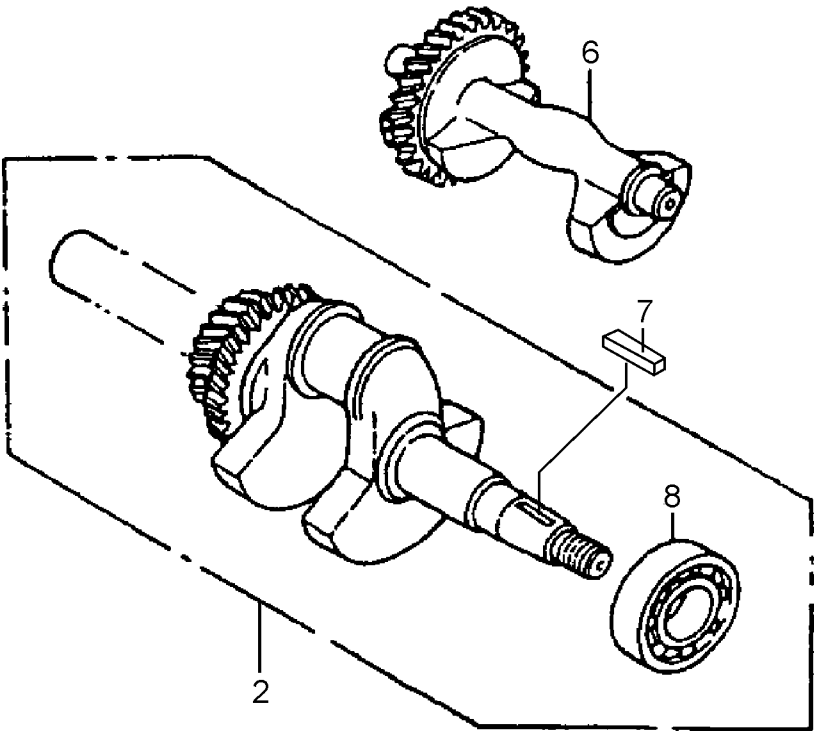

## **CRANKSHAFT ASSY.**

---

<u>NO.</u>	<u>PART NO.</u>	<u>PART NAME</u>	<u>QTY.</u>	<u>REMARKS</u>
2	13310ZF6W12	CRANKSHAFT COMP. ....	1.....	INCLUDES ITEM W/#
6	13351ZE3010	WEIGHT, BALANCER	1	
7	90745ZE2600	KEY, 6.3X6.3X43	1	
8#	91001ZF6013	BEARING, RADIAL BALL	1	

# PISTON ASSY.

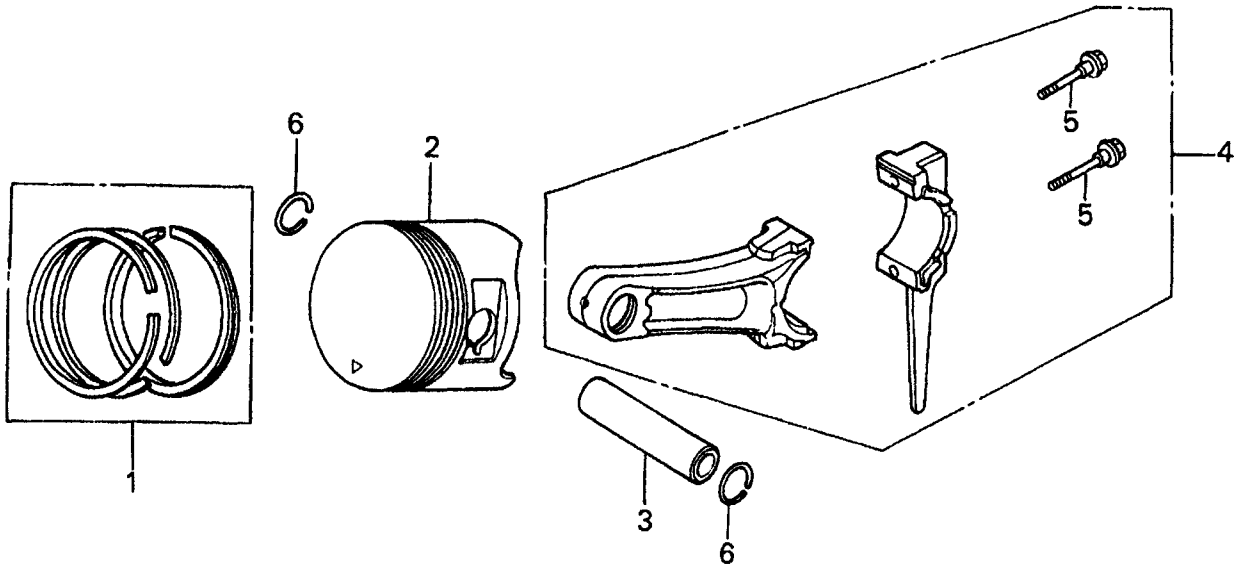



## PISTON ASSY.

---

<u>NO.</u>	<u>PART NO.</u>	<u>PART NAME</u>	<u>QTY.</u>	<u>REMARKS</u>
1	13010Z5K004	RING SET, PISTON (STD.)	1	
1	13011Z5K004	RING SET, PISTON (0.25)	1	
1	13012Z5K004	RING SET, PISTON (0.50)	1	
1	13013Z5K004	RING SET, PISTON (0.75)	1	
2	13101Z5T800	PISTON (STD.)	1	
2	13102Z5T800	PISTON (0.25)	1	
2	13103Z5T800	PISTON (0.50)	1	
2	13104Z5T800	PISTON (0.75)	1	
3	13111Z5T000	PIN, PISTON	1	
4	13200Z1C000	ROD ASSY., CONNECTING (STD.) .....	1.....	INCLUDES ITEMS W/#
4	13200Z1C305	ROD ASSY., CONNEC. (0.25 UNDER SIZE) ....	1.....	INCLUDES ITEMS W/#
5#	90001ZE8000	BOLT, CONNECTING ROD	2	
6	90601ZE3000	CLIP, PISTON PIN, 18MM	2	

# CAMSHAFT ASSY.

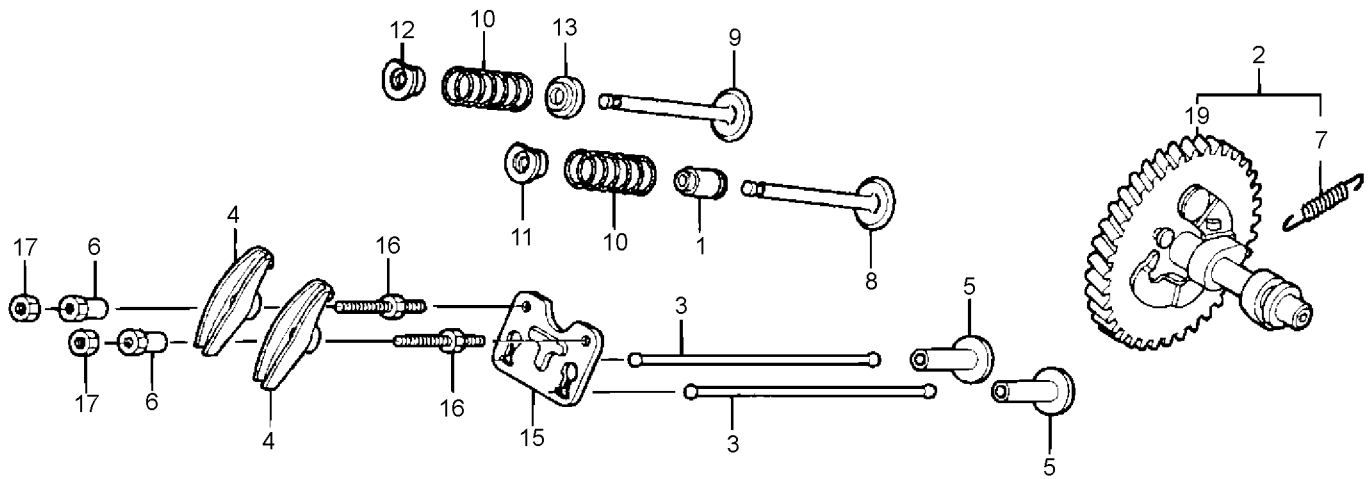

## CAMSHAFT ASSY.

<u>NO.</u>	<u>PART NO.</u>	<u>PART NAME</u>	<u>QTY.</u>	<u>REMARKS</u>
1	12209ZE8003	SEAL, VALVE STEM	1	
2	14100Z5K810	CAMSHAFT ASSY.....	1.....	INCLUDES ITEMS W/#
3	14410Z1C000	ROD, PUSH	2	
4	14431ZE2010	ARM, VALVE ROCKER	2	
5	14441ZE2000	LIFTER, VALVE	2	
6	14451ZE1013	PIVOT, ROCKER ARM	2	
7#	14568ZE1000	SPRING, WEIGHT RETURN	1	
8	14711Z5T000	VALVE, IN.	1	
9	14721Z5T000	VALVE, EX.	1	
10	14751Z1C000	SPRING, VALVE	2	
11	14771Z8S000	RETAINER, IN. VALVE SPRING	1	
12	14771Z8S000	RETAINER, IN. VALVE SPRING	1	
13	14775ZE2010	SEAT, VALVE SPRING	1	
15	14791Z1D000	GUIDE, PUSH ROD	1	
16	90012ZE0010	BOLT, PIVOT, 8MM	2	
17	90206ZE1000	NUT, PIVOT ADJUSTING	2	
19#	14100Z5K910	CAMSHAFT COMP.	1	

# LABEL ASSY.

---

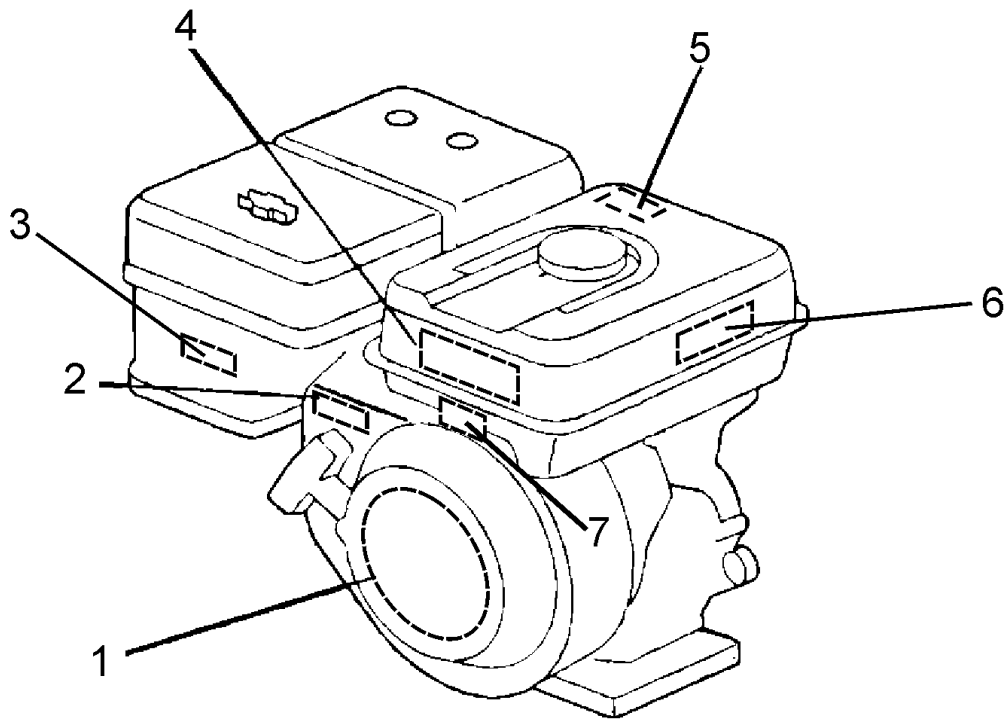

## **LABEL ASSY.**

---

<u>NO.</u>	<u>PART NO.</u>	<u>PART NAME</u>	<u>QTY.</u>	<u>REMARKS</u>
1	87521Z8T000	EMBLEM (GX340)	1	
2	87532ZH7000	MARK, THROTTLE INDICATION	1	
3	87528Z5T000	MARK, CHOKE	1	
4	87519Z4H000	MARK, OPERATOR CAUTION	1	
5	87539Z0J000	MARK, EX, CAUTION	1	
6	87516Z4H010	MARK, OPERATOR CAUTION	1	
7	87539Z0J800	MARK, EX. CAUTION	1	

# OPERATION AND PARTS MANUAL

## HERE'S HOW TO GET HELP

PLEASE HAVE THE MODEL AND SERIAL  
NUMBER ON-HAND WHEN CALLING

### UNITED STATES

#### *Multiquip Inc.*

(310) 537- 3700  
6141 Katella Avenue Suite 200  
Cypress, CA 90630  
E-MAIL: [mq@multiquip.com](mailto:mq@multiquip.com)  
WEBSITE: [www.multiquip.com](http://www.multiquip.com)

---

### CANADA

#### *Multiquip*

(450) 625-2244  
4110 Industriel Boul.  
Laval, Quebec, Canada H7L 6V3  
E-MAIL: [infocanada@multiquip.com](mailto:infocanada@multiquip.com)

### UNITED KINGDOM

#### *Multiquip (UK) Limited Head Office*

0161 339 2223  
Unit 2, Northpoint Industrial Estate, Globe Lane,  
Dukinfield, Cheshire SK16 4UJ  
E-MAIL: [sales@multiquip.co.uk](mailto:sales@multiquip.co.uk)

© COPYRIGHT 2023, MULTIQUIP INC.

Multiquip Inc, the MQ logo are registered trademarks of Multiquip Inc. and may not be used, reproduced, or altered without written permission. All other trademarks are the property of their respective owners and used with permission.

This manual MUST accompany the equipment at all times. This manual is considered a permanent part of the equipment and should remain with the unit if resold.

The information and specifications included in this publication were in effect at the time of approval for printing. Illustrations, descriptions, references and technical data contained in this manual are for guidance only and may not be considered as binding. Multiquip Inc. reserves the right to discontinue or change specifications, design or the information published in this publication at any time without notice and without incurring any obligations.

