

OPERATION MANUAL



MIX N' GO MODEL MC3PBAT MINI CONCRETE PLASTIC DRUM MIXER (BATTERY OPERATED)

Revision #0 (04/09/24)

To find the latest revision of this publication or associated parts manual, visit our website at:
www.multiquip.com



THIS MANUAL MUST ACCOMPANY THE EQUIPMENT AT ALL TIMES.



SILICOSIS/RESPIRATOR WARNINGS

WARNING



SILICOSIS WARNING

Grinding/cutting/drilling of masonry, concrete, metal and other materials with silica in their composition may give off dust or mists containing crystalline silica. Silica is a basic component of sand, quartz, brick clay, granite and numerous other minerals and rocks. Repeated and/or substantial inhalation of airborne crystalline silica can cause serious or fatal respiratory diseases, including silicosis. In addition, some authorities have listed respirable crystalline silica as a substance known to cause cancer. When cutting such materials, always follow the respiratory precautions mentioned above.

WARNING

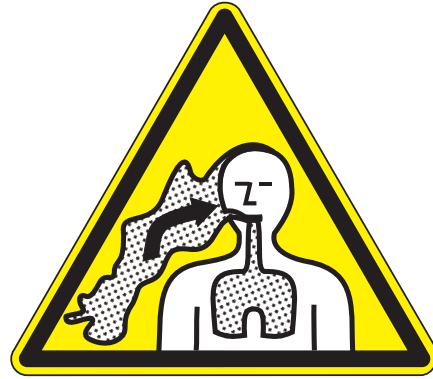

RESPIRATORY HAZARDS

Grinding/cutting/drilling of masonry, concrete, metal and other materials can generate dust, mists and fumes containing chemicals known to cause serious or fatal injury or illness, such as respiratory disease, cancer, birth defects or other reproductive harm. If you are unfamiliar with the risks associated with the particular process and/or material being cut or the composition of the tool being used, review the material safety data sheet and/or consult your employer, the material manufacturer/supplier, responsible governmental agencies and other sources on hazardous materials. Some authorities have published lists of substances known to cause cancer, reproductive toxicity, or other harmful effects.

Control dust, mist and fumes at the source where possible. In this regard use good work practices and follow the recommendations of the manufacturers or suppliers, and occupational and trade associations. Water should be used for dust suppression when wet cutting is feasible. When the hazards from inhalation of dust, mists and fumes cannot be eliminated, the operator and any bystanders should always wear approved respirators for the materials being used.

TABLE OF CONTENTS

Multiquip Mix N' Go Portable Concrete Mixer

Proposition 65..... 2
Silicosis/Respirator Warnings..... 3
Safety Information 6-9
Operation And Safety Decal 10
Specifications 11
Dimensions..... 12
General Information..... 13
Components 14
Assembly Instructions..... 15-17
Startup/Operation 18-20
Maintenance 21-23
Troubleshooting 24-25

NOTICE
Specifications and part numbers are subject to change without notice.

SAFETY INFORMATION

Do not operate or service the equipment before reading the entire manual. Safety precautions should be followed at all times when operating this equipment. Failure to read and understand the safety messages and operating instructions could result in injury to yourself and others.



SAFETY MESSAGES

The four safety messages shown below will inform you about potential hazards that could injure you or others. The safety messages specifically address the level of exposure to the operator and are preceded by one of four words: **DANGER**, **WARNING**, **CAUTION** or **NOTICE**.

SAFETY SYMBOLS

! **DANGER**

Indicates a hazardous situation which, if not avoided, **WILL** result in **DEATH** or **SERIOUS INJURY**.

! **WARNING**

Indicates a hazardous situation which, if not avoided, **COULD** result in **DEATH** or **SERIOUS INJURY**.





! **CAUTION**

Indicates a hazardous situation which, if not avoided, **COULD** result in **MINOR** or **MODERATE INJURY**.

NOTICE

Addresses practices not related to personal injury.

Potential hazards associated with the operation of this equipment will be referenced with hazard symbols which may appear throughout this manual in conjunction with safety messages.

Symbol	Safety Hazard
	Explosion hazards
	Fire hazards
	Burn hazards
	Rotating parts hazards

SAFETY INFORMATION

GENERAL SAFETY

CAUTION

- **NEVER** operate this equipment without proper protective clothing, shatterproof glasses, respiratory protection, hearing protection, steel-toed boots and other protective devices required by the job or city and state regulations.



- Avoid wearing jewelry or loose fitting clothes that may snag on the controls or moving parts as this can cause serious injury.

- **NEVER** operate this equipment when not feeling well due to fatigue, illness or when under medication.



- **NEVER** operate this equipment under the influence of drugs or alcohol.



- **ALWAYS** clear the work area of any debris, tools, etc. that would constitute a hazard while the equipment is in operation.

- **ALWAYS** check the equipment for loosened threads or bolts before starting.

- **DO NOT** use the equipment for any purpose other than its intended purposes or applications.

NOTICE

- This equipment should only be operated by trained and qualified personnel 18 years of age and older.

- Whenever necessary, replace nameplate, operation and safety decals when they become difficult read.

- Manufacturer does not assume responsibility for any accident due to equipment modifications. Unauthorized equipment modification will void all warranties.

- **NEVER** use accessories or attachments that are not recommended by Multiquip for this equipment. Damage to the equipment and/or injury to user may result.

- **ALWAYS** know the location of the nearest **fire extinguisher**.



- **ALWAYS** know the location of the nearest **first aid kit**.



- **ALWAYS** know the location of the nearest phone or **keep a phone on the job site**. Also, know the phone numbers of the nearest **ambulance, doctor and fire department**. This information will be invaluable in the case of an emergency.



SAFETY INFORMATION

MIXER SAFETY

DANGER

- **NEVER** operate the equipment in an explosive atmosphere or near combustible materials. An explosion or fire could result causing severe **bodily harm or even death.**



- **DO NOT** mix **flammable** or **explosive** substances.

WARNING

- **NEVER** place your hands inside the drum while starting or operating this equipment.
- **NEVER** disconnect any **emergency or safety devices.** These devices are intended for operator safety. Disconnection of these devices can cause severe injury, bodily harm or even death. Disconnection of any of these devices will void all warranties.



CAUTION

- **NEVER** lubricate components or attempt service on a running machine.
- **NEVER** place hands inside mixing drum while drum is rotating.

NOTICE

- **ALWAYS** keep the machine in proper running condition.
- **ALWAYS** ensure mixer is on level ground before mixing.
- Fix damage to machine and replace any broken parts immediately.
- **DO NOT** tip mixer onto drum mouth when the drum is rotating.
- Ensure the drum is rotating while filling and emptying the drum.
- **NEVER** operate mixer with drive belt cover removed.
- **ALWAYS** store equipment properly when it is not being used. Equipment should be stored in a clean, dry location out of the reach of children and unauthorized personnel.
- **DO NOT** spray water onto electronic components such as the controller or battery.

BATTERY SAFETY

DANGER

- **NEVER** disassemble, crush, or puncture the battery.
- **NEVER** expose the battery to fire or water to prevent potential hazards such as explosion, damage, or injury due to chemical reactions or short circuits.

CAUTION

- If the battery is leaking fluids or bulging, remove battery. **DO NOT** touch any fluids with bare hands. Using protective gloves, safely dispose battery.
- In case of eye contact with battery fluids, **DO NOT** rub eyes. Immediately flush eyes thoroughly with water for at least 15 minutes, lifting upper and lower lids, until no evidence of the fluid remains. Seek medical attention immediately.

NOTICE

- **DO NOT** attempt to modify or tamper with the battery or its components. Any modifications will void warranty.
- **DO NOT** discharge the battery to very low levels. Deep discharges can reduce the life span of lithium-ion batteries
- **DO NOT** expose the battery to extreme temperatures, either too hot or too cold. Safe storage/charging temperatures range from 115°F (46°C) ~ 40°F (4°C).
- **DO NOT** store battery in fully discharged state. It may permanently kill the battery.
- **ONLY** use OEM type battery charger.
- **NEVER** use unauthorized battery charger. Damage to battery may occur.
- **NEVER** store battery in direct sunlight, cover when necessary.
- **DO NOT** overcharge battery.
- **ALWAYS** inspect battery for signs of physical damage. **NEVER** use a bulging or swelling battery.
- **NEVER** spray battery with water.

TRANSPORTING SAFETY

CAUTION

- **NEVER** allow any person or animal to stand underneath the equipment while lifting.

NOTICE

- **ALWAYS** make sure forklift forks are inserted into pockets (if applicable) as far as possible when lifting the mixer.
- **NEVER** lift the equipment while the machine is running.
- **DO NOT** lift machine to unnecessary heights.
- **ALWAYS** tie down equipment during transport by securing the equipment with rope.

ENVIRONMENTAL SAFETY

NOTICE

- Dispose of hazardous waste properly. Examples of potentially hazardous waste is used gear oil, 
- **DO NOT** use food or plastic containers to dispose of hazardous waste.
- **DO NOT** pour waste or gear oil directly onto the ground, down a drain or into any water source.

OPERATION AND SAFETY DECAL

Machine Safety Decal

The Mix N' Go mixer is equipped with an operation and safety decal (Figure 1). This decal is provided for operator safety and maintenance information. The illustration below shows the decal as it appears on the machine. If the decal becomes unreadable a replacement decal can be ordered from the MQ Parts Dept.



Figure 1. Machine Operation/Safety Decal

Table 1. Battery Specifications

Type	48V 30Ah Lithium-Ion Battery
Dimensions (L x W x H)	3.5 x 5.25 x 18.25 in (88.9 x 133.35 x 463.55 mm)
Approximate Operating Time ¹	3 hour 45 minutes
Charge Time	6.5 hours
Charger Type	115 VAC, 5 Amp
Dry Net Weight:	16 lbs. (7.25 kg)
¹ Based on a 240 lb. (109 kg) load. Less weight equals longer run time.	

Table 2. Mixer Specifications

Height	34 in. (863.6 mm)
Width	23-5/8 in. (584.2 mm)
Length	48-1/2 in. (1,219.2 mm)
Stand Weight	35 lbs. (15.9 Kg)
Maximum Drum Capacity	4.5 cu. ft. (0.13 m ³)
Maximum Mixing Capacity	3.0 cu. ft. (0.08 m ³)
Drum Rotation (Full Load)	25 RPM
Controller	Type: Y, IA40012K-P- 48 Volt, 550 Watt
Gear Box	50:1 Reduction
Gear Box Oil	SAE 80W-90, API GL-5
Electric Motor	48 Volt 550 Watt (3/4 HP) @ 3200 rpm

DIMENSIONS

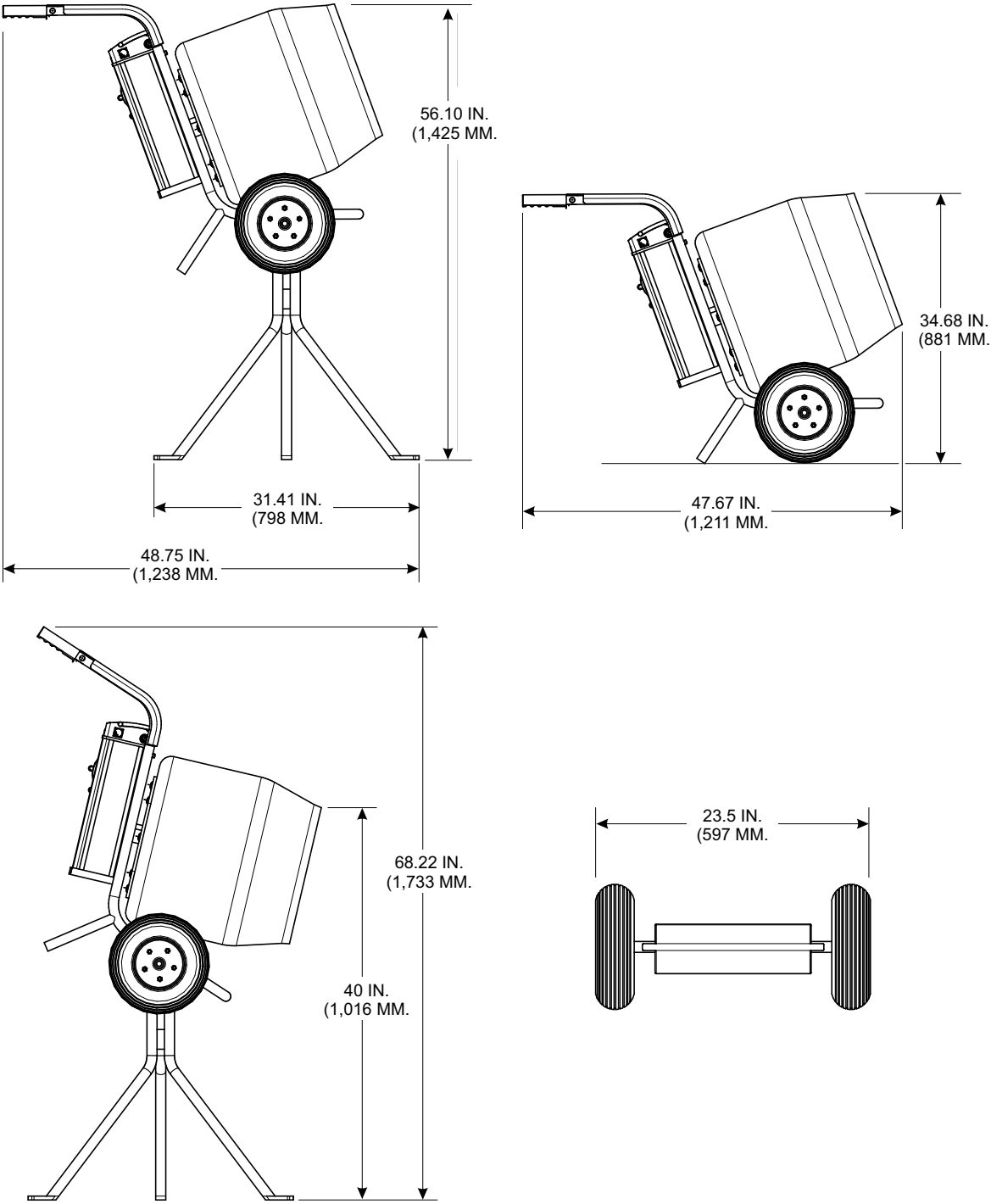

Figure 2. Dimensions

GENERAL INFORMATION

APPLICATION

This mixer is only intended for the production of concrete and mortar. The mixer must be used for its intended purposes and is not suitable for the mixing of flammable or explosive substances. The mixer must not be used in an explosive atmosphere.

POWER PLANT

This portable mixer is powered by a 48V 30Ah lithium-ion battery. Which will allow the mixer drum to rotate at 25 rpm's.

DRUM ASSEMBLY

The drum is instantly removable by unscrewing counter-clockwise. When inserting drum onto gearbox shaft, make sure that drum is fully screwed onto shoulder or threads may be damaged. Use extreme care when screwing on the drum, spinning drum onto the gearbox shaft too fast may damage gearbox.

ELECTRICAL

To ensure complete compatibility, only operate machine with the OEM battery from the manufacturer. Operating the mixer with the specified battery not only optimizes performance but also mitigates risks, ensuring a safer working environment for the operator.

GEARBOX

The gearbox oil level has been preset at the factory prior to shipping. Replace gearbox oil every 6 months. Make sure the gearbox oil is cool before removing the filler plug. Fill up with SAE 80W-90, API GL-5 or similar type gear oil.

TRANSPORTING THE MIXER

Use a ramp (Figure 3) to load and unload the mixer from the transport vehicle. Never drop the mixer onto the ground; damage to the mixer could result.

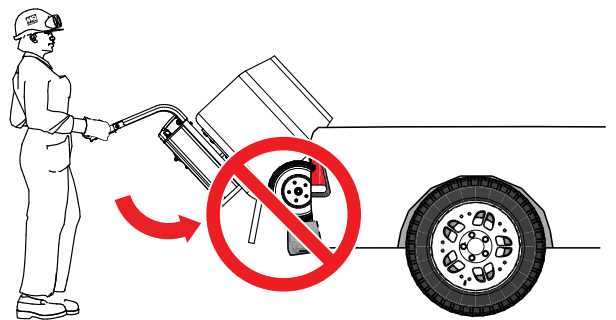
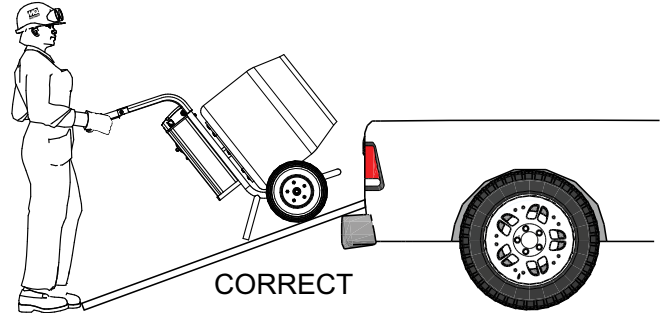

Figure 3. Mixer Loading

COMPONENTS

Figure 4 shows the basic components of the MC3PBAT Mixer. Support stand is optional.

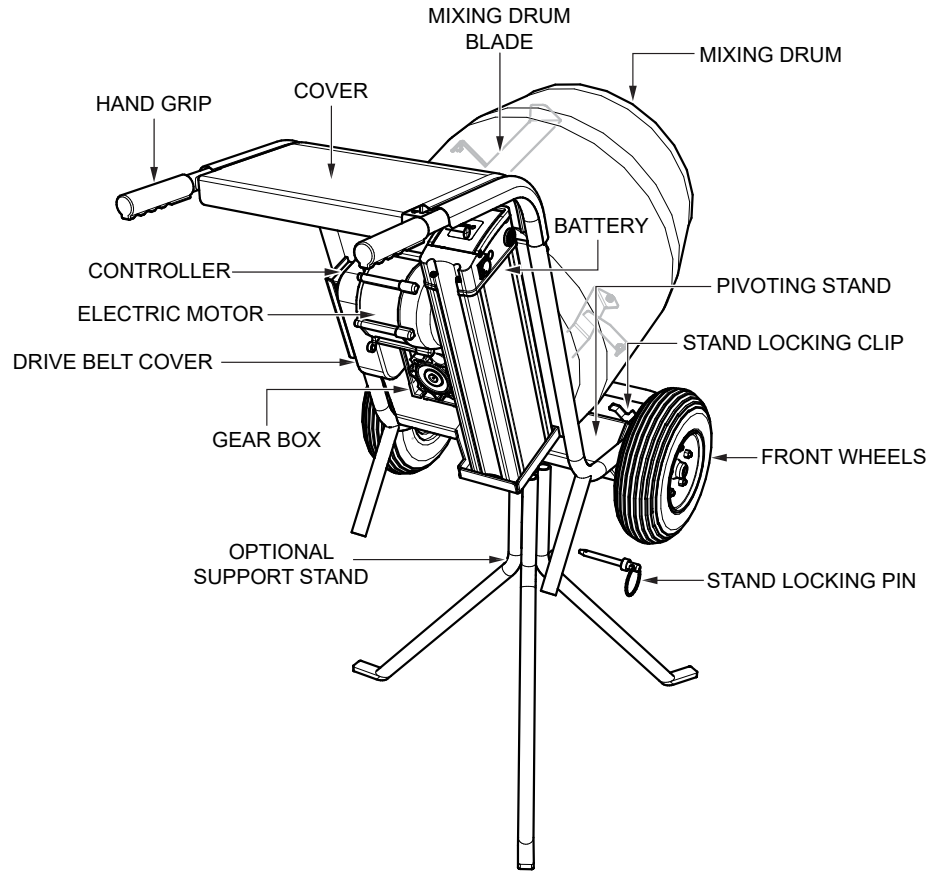

Figure 4. Mixer Components

Table 3. Mixing Hints				
Applications				
Foundations	Driveways Repairs	Floor Slabs and Patios	Sidewalks, Steps, Curbs and Steps	
Concrete Mixing Options (Using Premixed Bag Material)				
Approx. Bags	Bag Size	Approx. Starting Water	Approx. Final Water	Approx. Yield Per Bag
6	40 lbs. (18 kg)	3 pt. (1.5 qt.)	3~4 pt. (1.5~2.0 qt.)	0.30 cu. ft.
4	60 lbs. (27 kg)	4 pt. (2.0 qt.)	4~7 pt. (2.0~3.5 qt.)	0.45 cu. ft.
3	80 lbs (36 kg)	6 pt. (3.0 qt.)	7~9 pt. (3.5~4.5 qt.)	0.60 cu. ft.
Self Field Mixing				
1 part portland cement, 2 parts all purpose sand (ASTM C-33), 3 parts all purpose gravel (ASTM C-33)				

ASSEMBLY INSTRUCTIONS

ASSEMBLY

1. Remove the mixer drum and associated components from the packing container (Figure 5). The following components are enclosed in the shipping container.

- Wheels (2), Cotter Pins (2), Washers (2)
- Mixing Drum, Battery
- Frame (Controller, Gearbox and Axle)

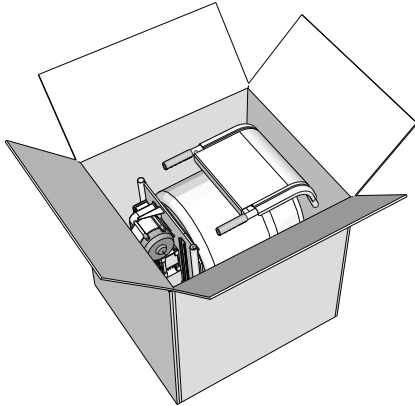

Figure 5. Shipping Container

Wheel Installation

1. Remove both wheels and wheel retaining hardware from the shipping container.
2. Position wheels over axle, install washers, secure with cotter pins Figure 6.

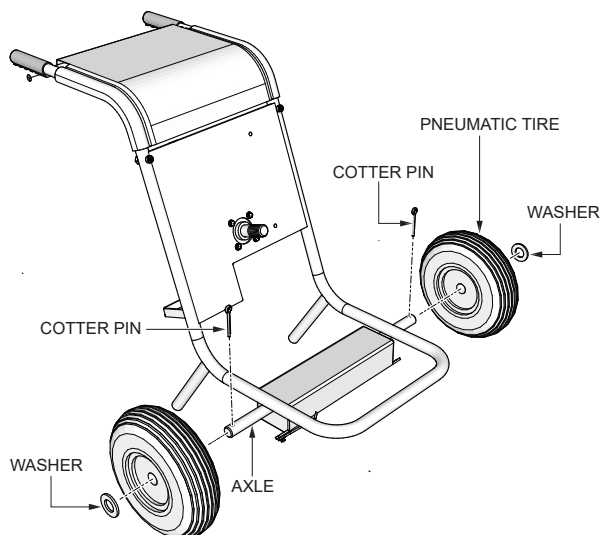

Figure 6. Wheel Installation

Top Cover Installation

1. Place the mixer frame on a secure level surface, and attach the top cover as shown in Figure 7.

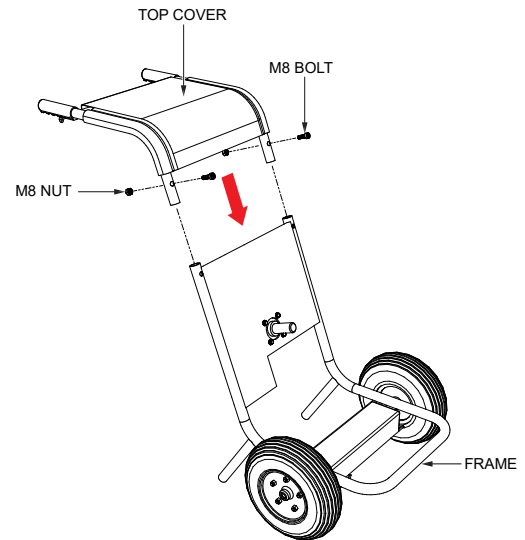

Figure 7. Top Cover Placement

Drum Installation

NOTICE

DO NOT spin the drum on fast, as this may damage the gearbox.

Fit the mixing drum onto gearbox shaft as shown in Figure 8. Rotate drum in a clockwise direction, make sure the drum fits right up to the shoulder on the gearbox shaft.

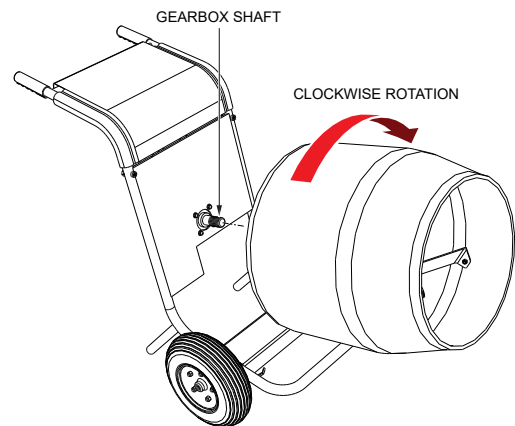

Figure 8. Mixing Drum Installation

ASSEMBLY INSTRUCTIONS

Battery Installation

1. Remove the battery from the packing container. It can be located inside the mixing drum.
2. Fully lift the top cover on the mixer.
3. Make sure key switch (Figure 9) is in the **unlocked** position. Locking pin is **not extended**.

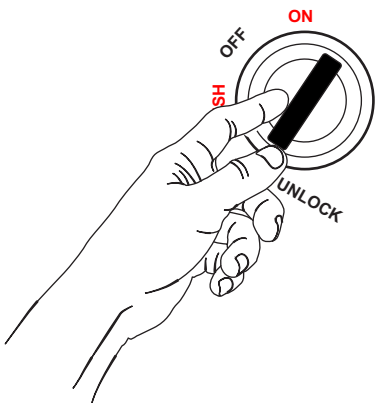

Figure 9. Key Switch Unlocked Position

4. As shown in Figure 10, grip the battery by its handle and align the battery rail with the battery track on the mixer frame.

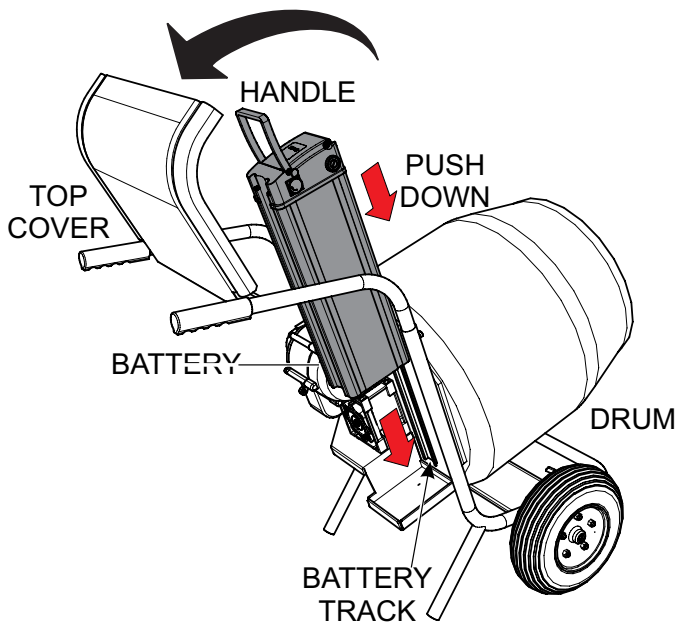

Figure 10. Battery Placement

5. Push down on the battery (Figure 10) until it is **fully seated**.

6. To lock the battery (Figure 11), place the key switch in the **OFF** position, locking pin is **extended**.

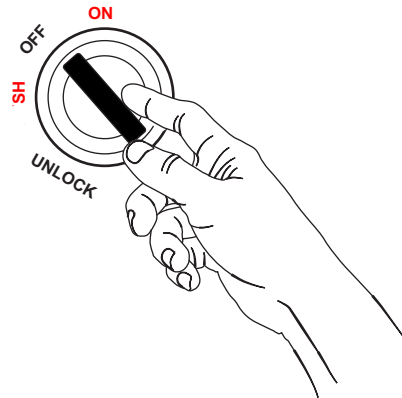

Figure 11. Key Switch OFF Position

Support Stand Installation (Option)

1. Place the two halves of the optional support stand together (Figure 12). The left support stand fits into the center boss on the right support stand.
2. Insert the adapter pin through bosses as shown in Figure 12. Once the adapter pin has been inserted and aligned, insert the locking pin. Place the round part of the locking pin over the bottom section of the adapter pin.

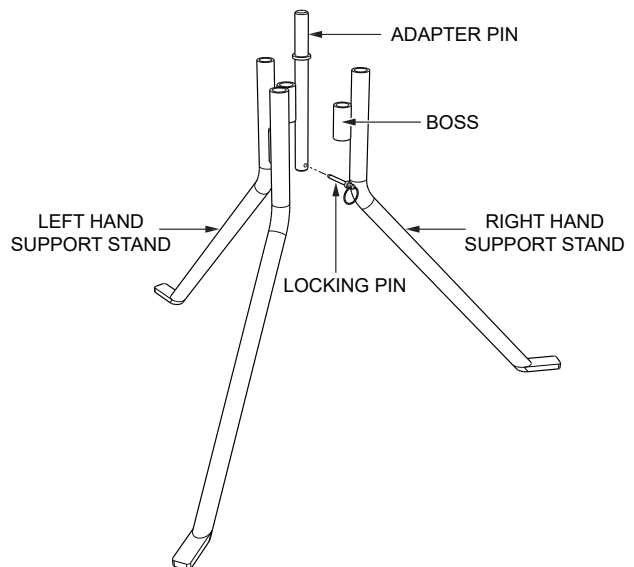

Figure 12. Optional Support Stand

ASSEMBLY INSTRUCTIONS

3. Tip mixer onto mouth as shown in Figure 13, and insert support stand into frame swivel point.

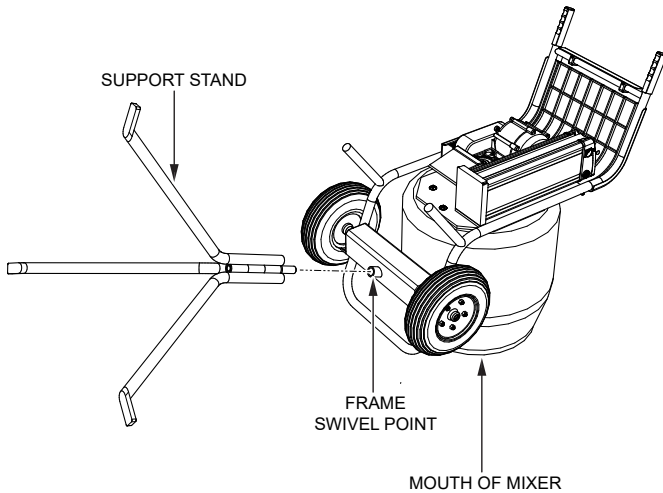

Figure 13. Attaching Support Stand

Locking Mixing Drum

1. Before attempting to lift mixer, locate the frame locking clip. Attach the locking clip as shown in Figure 14. This will prevent the mixing drum from moving when the mixer is positioned in an upright position.

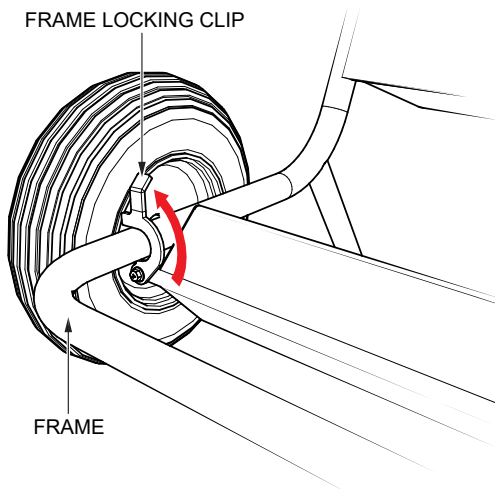

Figure 14. Frame Locking Clip

2. **DO NOT** tilt the mixer on a wet, smooth or slippery surface (Figure 15).



SLIPPERY OR WET SURFACE

Figure 15. Slippery or Wet Surfaces

3. Once the stand has been assembled, and the locking clip has been secured, begin tilting the mixer to an upright position. Remember always tilt from the front of the mixer as shown in Figure 16.

STEP 1

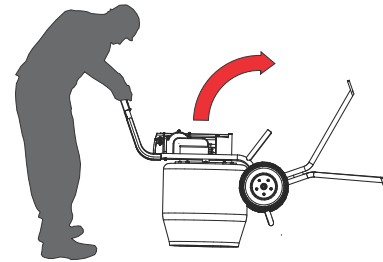

STEP 2

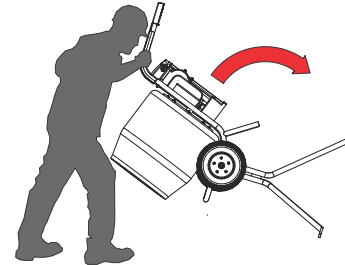

STEP 3

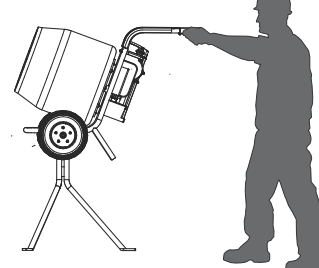

MIX POSITION

Figure 16. Tilting Mixer to Upright Position

STARTUP/OPERATION

STARTING

NOTICE

DO NOT attempt to operate the mixer until the Safety, General Information and Inspection sections have been read and understood.

1. Before starting, make sure mixer is positioned on a secure flat surface to prevent tipping.
2. **NEVER!** operate mixer with the drive belt cover removed.
3. Make sure the **controller power cord** is plugged into the **battery power receptacle** as shown in Figure 17.
4. Make sure the **electric motor power cord** is plugged into the **controller 9-pin receptacle** as shown in Figure 17.

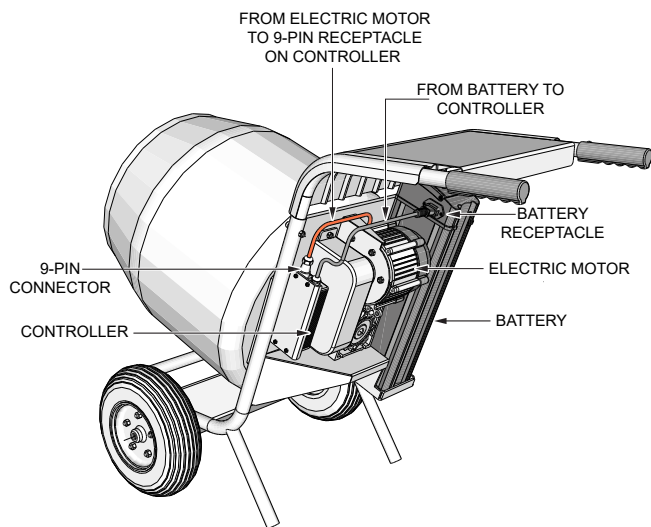

Figure 17. Controller Power Cord

5. Place key switch in the **ON** position (Figure 18) and verify that drum begins to rotate clockwise as viewed from the operator's position.

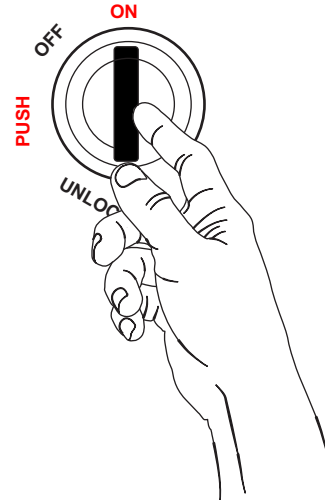

Figure 18. Key Switch ON Position

CAUTION

Be careful to only place the **tip** (Figure 20) of the shovel inside the drum. Placing the shovel all the way inside (Figure 19) the drum will cause the shovel to strike the blades. This condition will make the shovel rotate, and could cause injury to personnel.

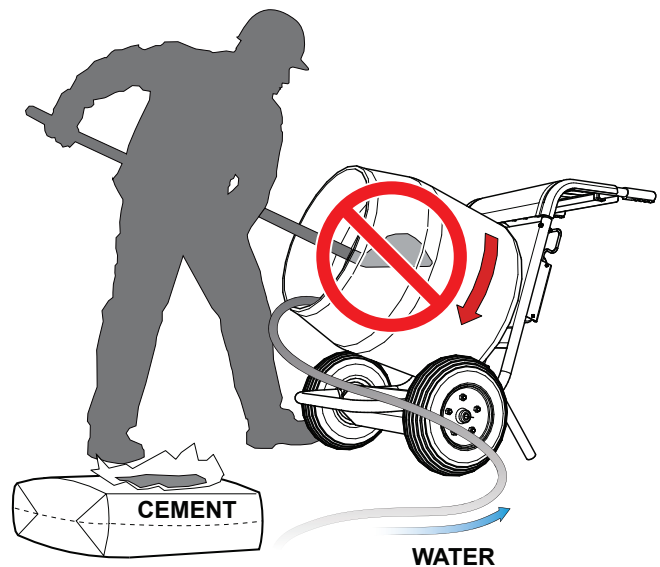

Figure 19. Shovel Inserted Too far

STARTUP/OPERATION

- As the drum rotates, this will allow the mixing process to begin. Use a shovel (Figure 20) to place the cement mix inside the drum, add water as required.

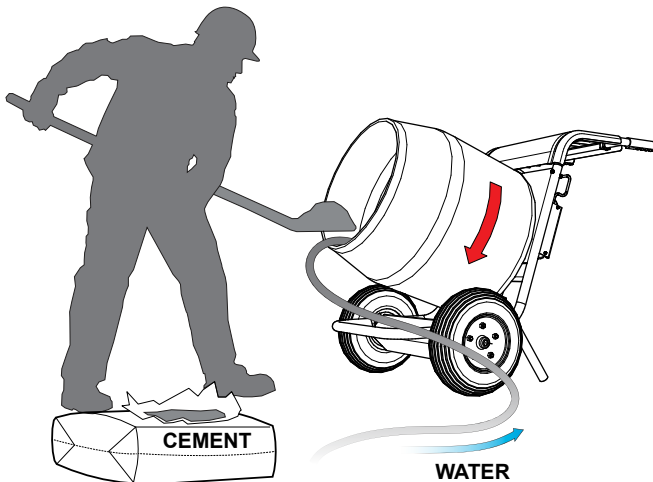

Figure 20. Mixing Process

- See Table 3 for mixing hints. **NEVER!** place hands inside the drum while the drum is rotating.

SHUTDOWN

- Place key switch in the **OFF** position (Figure 21) and verify that the drum stops rotating.

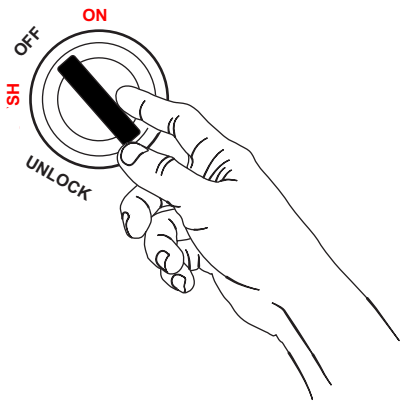

Figure 21. Key Switch OFF Position

Battery Removal

- Place key switch in the **PUSH** position (Figure 22).

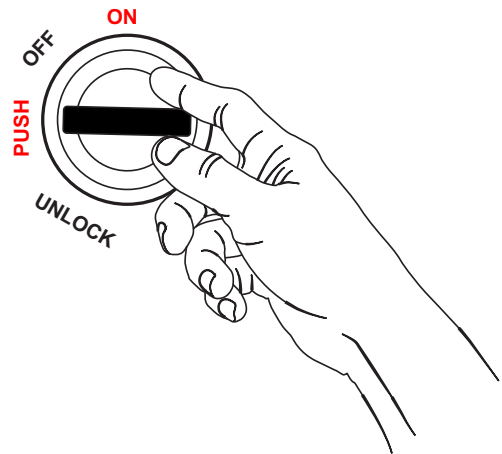

Figure 22. Key Switch **PUSH** Position

- Next, push inward on the key switch and turn to the **UNLOCK** position (Figure 23). This will cause the battery locking pin to be **retracted**.

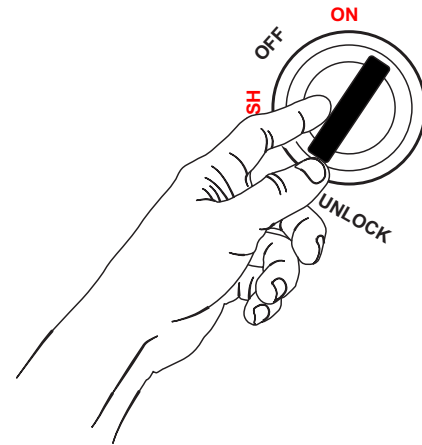

Figure 23. Key Switch UnLock Position

STARTUP/OPERATION

3. Fully lift the top cover on the mixer and remove keys from battery key switch.
4. Next, grip the battery handle (Figure 24) and lift the battery from the mixer's battery track.

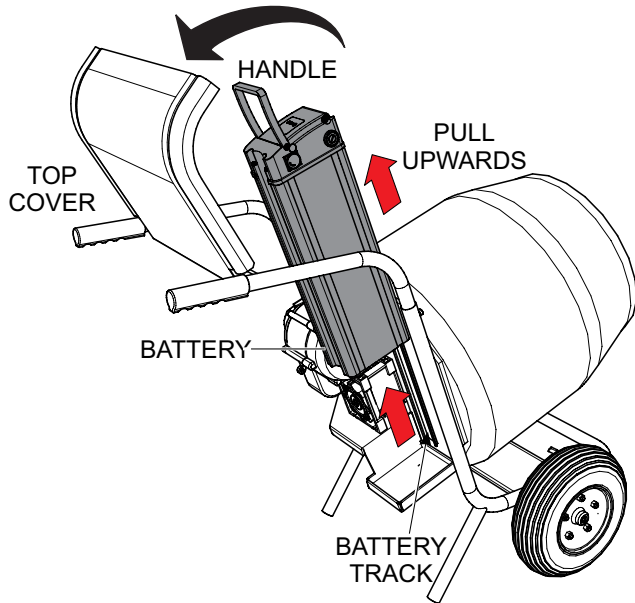

Figure 24. Battery Removal

5. Store battery in a clean dry location, free of dust and debris.

Drum Removal/Cleaning

1. Clean entire mixer inside and out with a mild detergent.
2. If it is desired to remove the drum (Figure 25) from the mixer, turn the drum counterclockwise to remove it from the gearbox shaft.

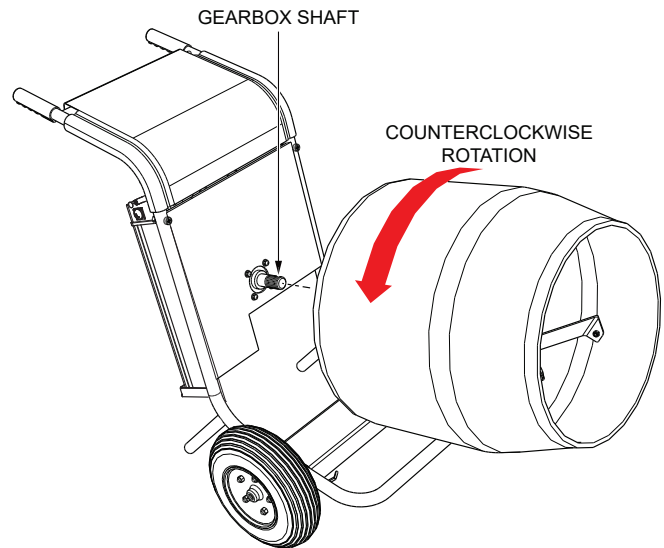

Figure 25. Mixing Drum Removal

3. Store mixer and drum in a clean dry location, free of dust and debris.

DRIVE BELT INSPECTION (ONCE A YEAR)

1. Remove the drive belt cover as shown in Figure 26.
2. Next inspect the drive belt for wear. If it shows signs of wear or cracks, replace drive belt.
3. Reinstall drive belt cover. Tighten retaining screws securely.

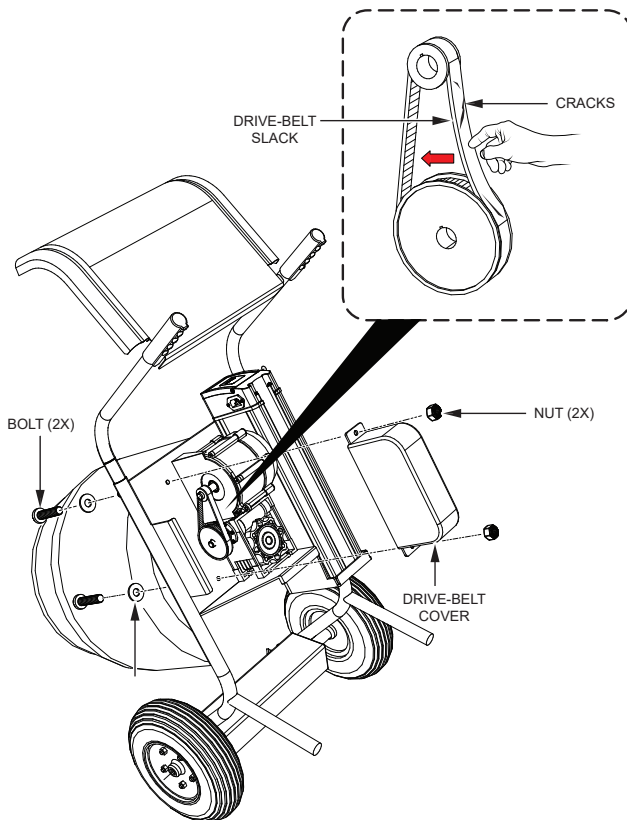

Figure 26. Drive Belt Inspection

BATTERY CHARGER

1. Disconnect/remove controller power cord (Figure 27A) from battery.
2. Slide charger protective receptacle cap (Figure 27B) to open position.
3. Insert battery charger connector (plug) into battery charging receptacle (Figure 27C).
4. Insert battery charger AC plug into a 120 VAC receptacle (Figure 27D).

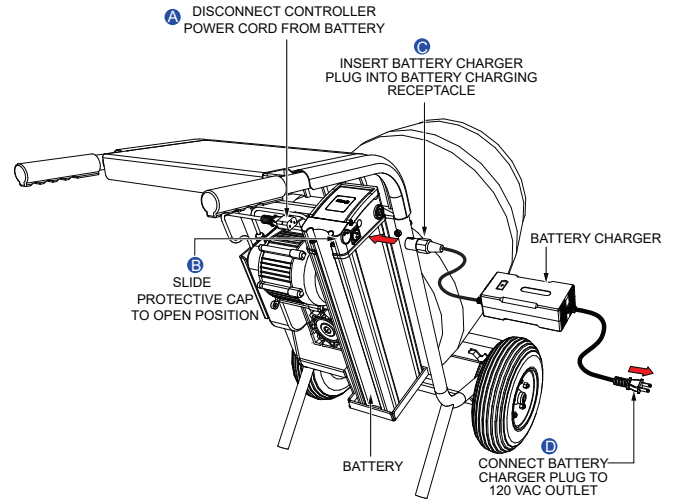

Figure 27. Charging Battery

5. Place key switch in the **ON** position and verify that the battery status LED on the battery charger is **RED** (Figure 28A), indicating battery is charging.
6. Battery is fully charged when the battery status LED on the battery charger is **GREEN** (Figure 28B).

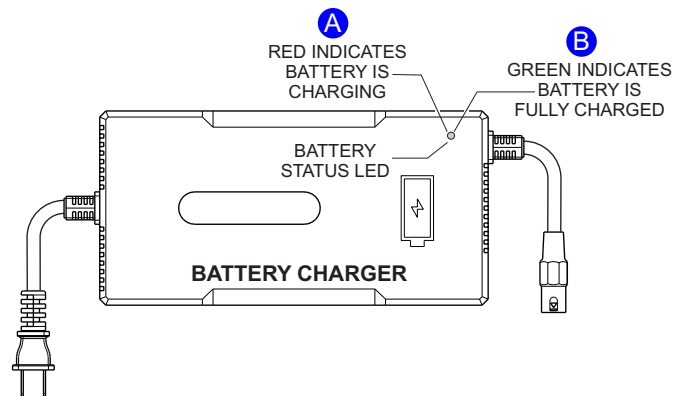

Figure 28. Battery Charger Status LED

MAINTENANCE

GEARBOX OIL REPLACEMENT (EVERY 6 MONTHS)

NOTICE

Replace gearbox oil every 6 months with SAE 80W-90, API GL-5 type gear oil. Make sure oil is cool before draining.

1. Tilt mixer in an upward position so that it is level (not tilted). Place a block of wood (Figure 29) underneath the frame to keep the mixer level.

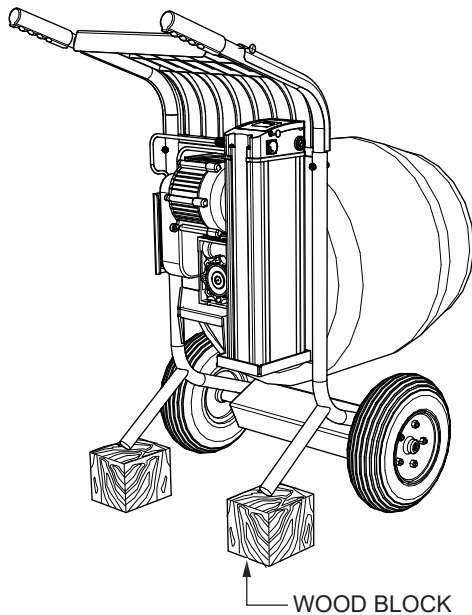

Figure 29. Leveling Mixer

2. Using a 5 mm allen-wrench, remove plug (oil filler port) on top of gearbox as shown in Figure 30.

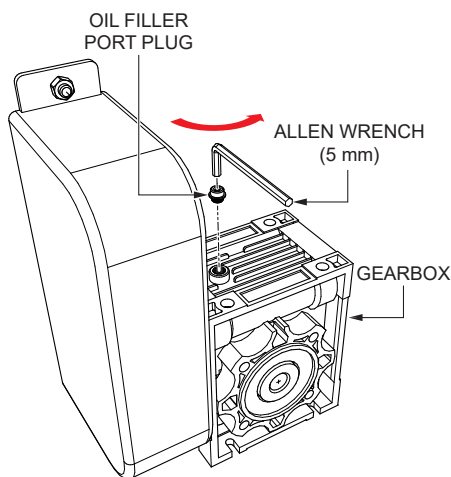

Figure 30. Removing Oil Filler Port Plug

3. Next, place a oil pan (Figure 31) underneath the oil drain plug to catch the oil.

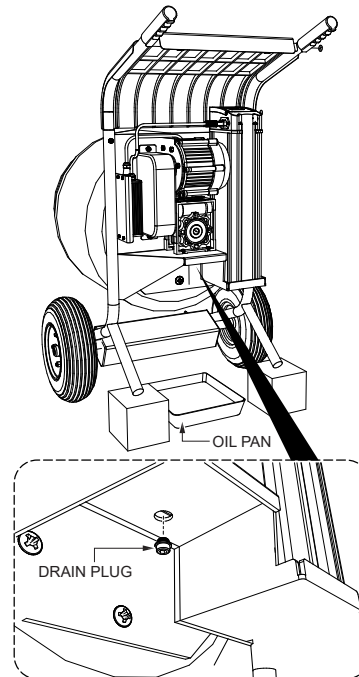

Figure 31. Oil Pan Placement

4. Using a 5 mm allen-wrench, remove *oil drain plug* at the bottom of gearbox as shown in Figure 32.

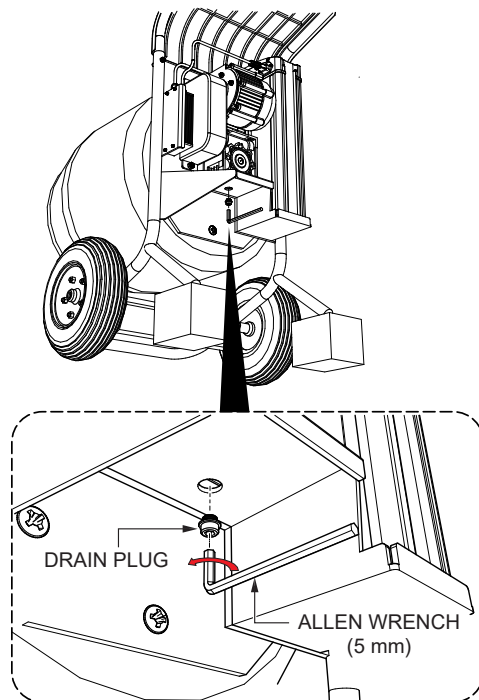

Figure 32. Removing Oil Drain Plug

5. Let oil completely drain into oil pan (Figure 33).

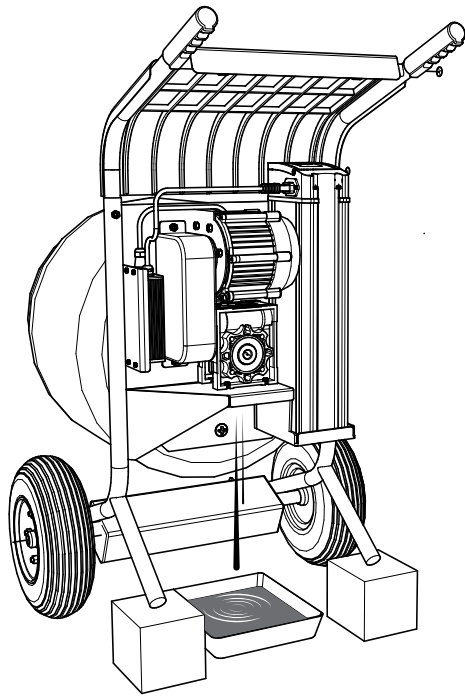

Figure 33. Draining Oil

6. Using a 5 mm allen-wrench, reinstall **oil drain plug** at the bottom of gearbox as shown in Figure 34. Tighten plug securely.

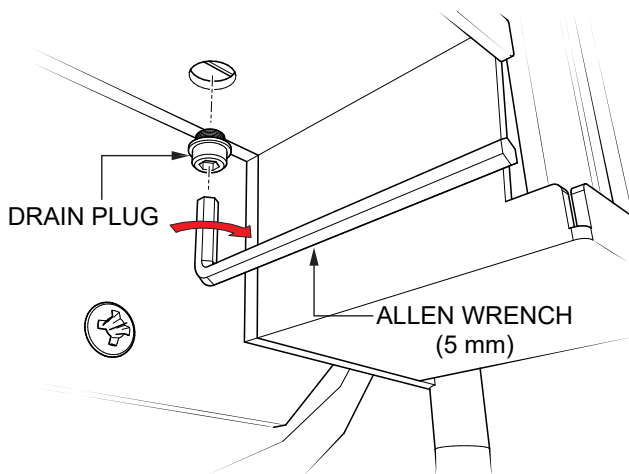

Figure 34. Installing Oil Drain Plug

7. Insert oil filler hose from gear oil canister into **oil filler port** as shown in Figure 35.

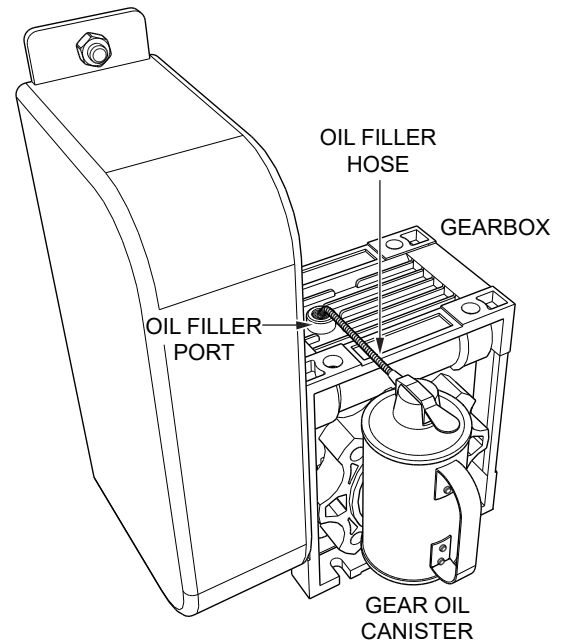

Figure 35. Adding Gear Oil

8. Squeeze lever on oil canister and fill gearbox with SAE 80W-90, API GL-5 type gear oil to a capacity of 3.7~4.0 oz. (110~120 ml.).

9. Reinstall gearbox filler port plug (Figure 36). Tighten securely.

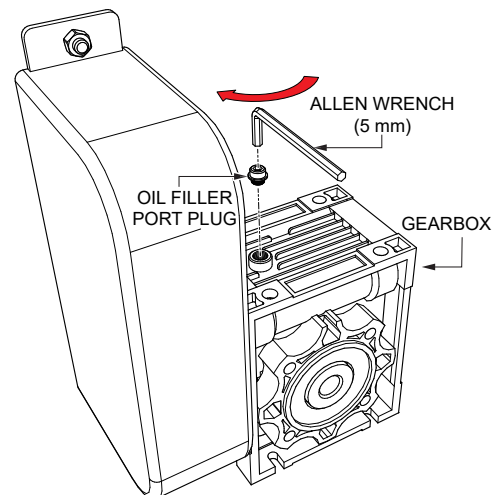

Figure 36. Reinstalling Oil Filler Port Plug

TROUBLESHOOTING

Troubleshooting (Mixer)		
Symptom	Possible Problem	Solution
Drum rotates slow.	Defective electric motor, electric motor pinion gear or bearings?	Check that the electric motor pinion gear and bearings are not worn. Replace components if necessary. Replace electric motor if necessary.
	Defective gearbox or bearings?	Inspect the gearbox and bearings for wear. Replace if necessary.
	Loose or defective pulley?	Inspect pulley. Tighten or replace pulley if necessary.
	Worn drive belt?	Replace drive belt.
	Loose pulley?	Tighten or replace pulley.
Drum does not rotate at all or is slipping.	Incorrect or no voltage being supplied to electric motor?	Check that the electric motor has the correct supply voltage.
	Power to electric motor?	Check if the battery is charged properly. Recharge the battery if necessary.
		Inspect the cable connections between the battery, controller and motor for any loose connections or damage. Tighten or repair as needed.
		Check that battery ignition switch was placed in the ON position.
		Inspect and test ignition switch.
	Broken, noisy or loose drive belt?	Inspect or replace drive belt.
	Defective electric motor?	Replace electric motor.
	Defective controller motor?	Replace controller motor.
Defective gearbox?	Inspect gearbox for proper oil capacity.	
Weak or inconsistent electric motor performance.	Low voltage?	Check the battery voltage with a multimeter to ensure it's within the recommended range. Charge or replace the battery if voltage is low.
	Defective electric motor or gearbox?	Inspect the motor and gearbox for any signs of debris or contamination. Clean or replace if necessary.
	Gearbox oil level low?	Inspect box for proper oil capacity.
	Loose wiring connections?	Check for any loose wiring connections, tighten them securely.

TROUBLESHOOTING

Troubleshooting (Mixer)		
Symptom	Possible Problem	Solution
Electric motor overheating.	Motor running hot?	Allow the motor to cool down by turning off the mixer and letting it rest for awhile.
	Mixer load is too large?	Ensure that the mixer is not overloaded with excessive material. Reduce the load if necessary.
	Concrete debris on cooling fins or motor?	Check for concrete splatter around motor and cooling fins restricting air flow. Remove any contamination with wire brush.
Battery draining quickly.	Can battery hold a charge?	Verify that the battery is holding a charge properly. If not, it may need to be replaced.
	Has ignition key been left in the ON position?	Place ignition key in the OFF position when mixer is not in use.
Intermittent power loss.	Battery cable plug loose?	Make sure battery cable is seated correctly into battery receptacle.
	Battery cable connection at controller is loose?	Clean and tighten battery cable connection at controller end.
	Loose electric motor or battery cables?	Inspect the electric motor and battery cables for any signs of damage. Make sure both cables are secured tightly.

OPERATION MANUAL

HERE'S HOW TO GET HELP

PLEASE HAVE THE MODEL AND SERIAL
NUMBER ON-HAND WHEN CALLING

UNITED STATES

Multiquip Inc.

(310) 537- 3700
6141 Katella Avenue Suite 200
Cypress, CA 90630
E-MAIL: mq@multiquip.com
WEBSITE: www.multiquip.com

CANADA

Multiquip

(450) 625-2244
4110 Industriel Boul.
Laval, Quebec, Canada H7L 6V3
E-MAIL: infocanada@multiquip.com

UNITED KINGDOM

Multiquip (UK) Limited Head Office

0161 339 2223
Unit 2, Northpoint Industrial Estate, Globe Lane,
Dukinfield, Cheshire SK16 4UJ
E-MAIL: sales@multiquip.co.uk

© COPYRIGHT 2024, MULTIQIP INC.

Multiquip Inc, the MQ logo are registered trademarks of Multiquip Inc. and may not be used, reproduced, or altered without written permission. All other trademarks are the property of their respective owners and used with permission.

This manual MUST accompany the equipment at all times. This manual is considered a permanent part of the equipment and should remain with the unit if resold.

The information and specifications included in this publication were in effect at the time of approval for printing. Illustrations, descriptions, references and technical data contained in this manual are for guidance only and may not be considered as binding. Multiquip Inc. reserves the right to discontinue or change specifications, design or the information published in this publication at any time without notice and without incurring any obligations.

