

OPERATION MANUAL



MODELS
MC44SH
MC44SE
CONCRETE MIXER
(HONDA GX160 SERIES GASOLINE ENGINES)

Revision #11 (06/15/26)

To find the latest revision of this publication
or associated parts manual, visit our
website at: www.multiquip.com



THIS MANUAL MUST ACCOMPANY THE EQUIPMENT AT ALL TIMES.

FUEL AND CHEMICAL EXPOSURE WARNINGS



WARNING

Gasoline engine exhaust and some of its constituents, and some dust created by power sanding, sawing, grinding, drilling and other construction activities contains chemicals known to the State of California to cause cancer, birth defects and other reproductive harm. Some examples of these chemicals are:

- Lead from lead-based paints.
- Crystalline silica from bricks.
- Cement and other masonry products.
- Arsenic and chromium from chemically treated lumber.

Your risk from these exposures varies, depending on how often you do this type of work. To reduce your exposure to these chemicals: **ALWAYS** work in a well ventilated area, and work with approved safety equipment, such as dust masks that are specially designed to filter out microscopic particles.

SILICOSIS/RESPIRATORY WARNINGS

⚠️ WARNING

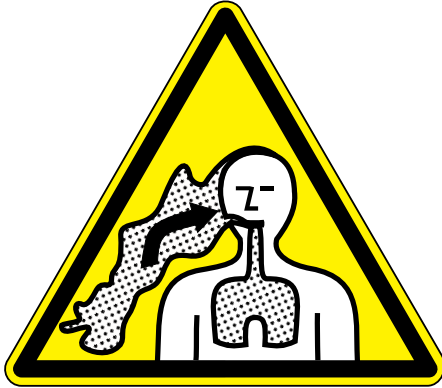

SILICOSIS WARNING

Grinding/cutting/drilling of masonry, concrete, metal and other materials with silica in their composition may give off dust or mists containing crystalline silica. Silica is a basic component of sand, quartz, brick clay, granite and numerous other minerals and rocks. Repeated and/or substantial inhalation of airborne crystalline silica can cause serious or fatal respiratory diseases, including silicosis. In addition, California and some other authorities have listed respirable crystalline silica as a substance known to cause cancer. When cutting such materials, always follow the respiratory precautions mentioned above.

⚠️ WARNING

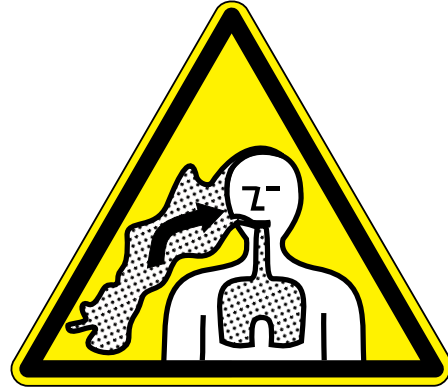

RESPIRATORY HAZARDS

Grinding/cutting/drilling of masonry, concrete, metal and other materials can generate dust, mists and fumes containing chemicals known to cause serious or fatal injury or illness, such as respiratory disease, cancer, birth defects or other reproductive harm. If you are unfamiliar with the risks associated with the particular process and/or material being cut or the composition of the tool being used, review the material safety data sheet and/or consult your employer, the material manufacturer/supplier, governmental agencies such as OSHA and NIOSH and other sources on hazardous materials. California and some other authorities, for instance, have published lists of substances known to cause cancer, reproductive toxicity, or other harmful effects.

Control dust, mist and fumes at the source where possible. In this regard use good work practices and follow the recommendations of the manufacturers or suppliers, OSHA/NIOSH, and occupational and trade associations. Water should be used for dust suppression when wet cutting is feasible. When the hazards from inhalation of dust, mists and fumes cannot be eliminated, the operator and any bystanders should always wear a respirator approved by NIOSH/MSHA for the materials being used.

TABLE OF CONTENTS

MC44S

Concrete Mixer

- Fuel and Chemical Exposure Warnings 2
- Silicosis/Respiratory Warnings 3
- Table of Contents..... 4
- Training Checklist 6
- Safety Information 7–12
- Mixer Specifications/Noise and Vibration 13
- Engine/Electric Motor Specifications 14
- General Information..... 15
- Basic Components (Mixer) 16
- Engine Components 17
- Electric Motor Components 18
- Towing Guidelines 19
- Safety Chain Connection..... 20
- Inspection 21–22
- Start-Up 23–24
- Operation..... 25–26
- Maintenance (Engine) 27–29
- Maintenance (Mixer)..... 30–32
- Troubleshooting (Mixer)..... 33
- Troubleshooting (Engine) 34–35

NOTICE

Specifications and part numbers are subject to change without notice.

TRAINING CHECKLIST

Training Checklist			
No,	Description	OK?	Date
1	Read operation manual completely.		
2	Machine layout, location of components, checking of engine oil levels.		
3	Fuel system, refueling procedure.		
4	Operation of controls (machine not running).		
5	Safety controls, safety stop switch operation.		
6	Emergency stop procedures.		
7	Machine transport and storage.		

SAFETY INFORMATION

Do not operate or service the equipment before reading the entire manual. Safety precautions should be followed at all times when operating this equipment. Failure to read and understand the safety messages and operating instructions could result in injury to yourself and others.





SAFETY MESSAGES

The four safety messages shown below will inform you about potential hazards that could injure you or others. The safety messages specifically address the level of exposure to the operator and are preceded by one of four words: **DANGER**, **WARNING**, **CAUTION** or **NOTICE**.

SAFETY SYMBOLS

 DANGER
<p>Indicates a hazardous situation which, if not avoided, WILL result in DEATH or SERIOUS INJURY.</p>
 WARNING
<p>Indicates a hazardous situation which, if not avoided, COULD result in DEATH or SERIOUS INJURY.</p>
 CAUTION
<p>Indicates a hazardous situation which, if not avoided, COULD result in MINOR or MODERATE INJURY.</p>
NOTICE
<p>Addresses practices not related to personal injury.</p>

Potential hazards associated with the operation of this equipment will be referenced with hazard symbols which may appear throughout this manual in conjunction with safety messages.

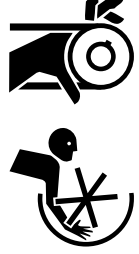
Symbol	Safety Hazard
	Lethal exhaust gas hazards
	Explosive fuel hazards
	Burn hazards
	Rotating parts hazards

SAFETY INFORMATION

GENERAL SAFETY

CAUTION

- **NEVER** operate this equipment without proper protective clothing, shatterproof glasses, respiratory protection, hearing protection, steel-toed boots and other protective devices required by the job or city and state regulations.



- Avoid wearing jewelry or loose-fitting clothes that may snag on the controls or moving parts as this can cause serious injury.

- **NEVER** operate this equipment when not feeling well due to fatigue, illness or when on medication.



- **NEVER** operate this equipment under the influence of drugs or alcohol.



- **ALWAYS** clear the work area of any debris, tools, etc. that would constitute a hazard while the equipment is in operation.

- **ALWAYS** check the equipment for loosened threads or bolts before starting.

- **DO NOT** use the equipment for any purpose other than its intended purposes or applications.

NOTICE

- This equipment should only be operated by trained and qualified personnel 18 years of age or older.
- Whenever necessary, replace nameplate, operation and safety decals when they become difficult to read.
- Manufacturer does not assume responsibility for any accident due to equipment modifications. Unauthorized equipment modification will void all warranties.
- **NEVER** use accessories or attachments that are not recommended by Multiquip for this equipment. Damage to the equipment and/or injury to the user may result.
- **ALWAYS** know the location of the nearest **fire extinguisher**.
- **ALWAYS** know the location of the nearest **first aid kit**.
- **ALWAYS** know the location of the nearest phone or **keep a phone on the job site**. Also, know the phone numbers of the nearest **ambulance, doctor** and **fire department**. This information will be invaluable in the case of an emergency.



MIXER SAFETY

DANGER

- **NEVER** operate the equipment in an explosive atmosphere or near combustible materials. An explosion or fire could result causing **severe bodily harm or even death**.



- **DO NOT** mix **flammable** or **explosive** substances.

SAFETY INFORMATION

WARNING

- **NEVER** place your hands inside the drum while starting or operating this equipment.
- **NEVER** disconnect any **emergency or safety devices**. These devices are intended for operator safety. Disconnection of these devices can cause **severe injury, bodily harm or even death**. Disconnection of any of these devices will void all warranties.
- Before operating the mixer, ensure that the safety grate is in position and correctly fitted.



CAUTION

- **NEVER** lubricate components or attempt service on a running machine.

NOTICE

- **ALWAYS** keep the machine in proper running condition.
- **ALWAYS** ensure the mixer is on level ground before mixing.
- Fix damage to the machine and replace any broken parts immediately.
- **DO NOT** tip the mixer onto the drum mouth when the drum is rotating.
- Ensure the drum is rotating while filling and emptying the drum.
- **ALWAYS** store equipment properly when it is not being used. Equipment should be stored in a clean, dry location out of the reach of children and unauthorized personnel.
- **ALWAYS** make sure the mixer is clean of dried materials. **DO NOT** allow material to build up inside the drum. Keep the drum, frame and wheels clean. Excess debris can fall off on the highway and/or build up on the frame and wheels, creating an unbalanced condition leading to premature metal fatigue.

ENGINE SAFETY (GASOLINE MODELS ONLY)

DANGER

- Engine fuel exhaust gases contain poisonous carbon monoxide. This gas is colorless and odorless, and can cause death if inhaled.
- The engine of this equipment requires an adequate free flow of cooling air. **NEVER** operate this equipment in any enclosed or narrow area where the free flow of air is restricted. If the air flow is restricted it will cause injury to people and property and serious damage to the equipment or engine.



WARNING

- **DO NOT** place hands or fingers inside the engine compartment when the engine is running.
- **NEVER** operate the engine with heat shields or guards removed.
- Keep fingers, hands, hair and clothing away from all moving parts to prevent injury.
- **DO NOT** remove the engine oil drain plug while the engine is hot. Hot oil will gush out of the oil tank and severely scald any persons in the general area of the mixer.



CAUTION

- **NEVER** touch the hot exhaust manifold, muffler or cylinder. Allow these parts to cool before servicing the equipment.
- Make certain the operator knows how to and is capable of turning the engine **OFF** in case of an emergency.



NOTICE

- **NEVER** run the engine without an air filter or with a dirty air filter. Severe engine damage may occur. Service the air filter frequently to prevent engine malfunction.
- **NEVER** tamper with the factory settings of the engine or engine governor. Damage to the engine or equipment can result if operating in speed ranges above the maximum allowable.



SAFETY INFORMATION

FUEL SAFETY (GASOLINE MODELS ONLY)

DANGER

- **DO NOT** start the engine near spilled fuel or combustible fluids. Fuel is **extremely flammable** and its vapors can cause an **explosion** if ignited.
- **ALWAYS** refuel in a well-ventilated area, away from sparks and open flames.
- **ALWAYS** use extreme caution when working with **flammable** liquids.
- **DO NOT** fill the fuel tank while the engine is running or hot.
- **DO NOT** overfill the tank, since spilled fuel can ignite if it comes into contact with hot engine parts or sparks from the ignition system.
- Store fuel in appropriate containers, in well-ventilated areas and away from sparks and flames.
- **NEVER** use fuel as a cleaning agent.
- **DO NOT** smoke around or near the equipment. **Fire or explosion** could result from fuel vapors or if fuel is spilled on a hot engine.



GENERATOR SAFETY

If using a generator to power the mixer, refer to the applicable generator manual safety information section.



ELECTRIC MOTOR SAFETY (ELECTRIC MODELS ONLY)

NOTICE

- Operate the electric motor only at the specified voltage indicated on the nameplate.
- **DO NOT** spray water onto the electric motor.
- **ALWAYS** disconnect the AC power plug from the power source before moving the mixer.
- **ALWAYS** make sure the ON/OFF switch on the electric motor is in the **OFF** position when not in use and before inserting the mixer's power plug into an AC receptacle.



Power Cord/Cable Safety

DANGER

- **NEVER** let power cords or cables **lay in water**.
- **NEVER** use **damaged** or **worn** cables or cords when connecting the equipment to a generator. Inspect the insulation for cuts.
- **NEVER** grab or touch a live power cord or cable with wet hands. The possibility exists of **electrical shock, electrocution or death**.
- Make sure power cables are securely connected. Incorrect connections may cause electrical shock and damage to the mixer.

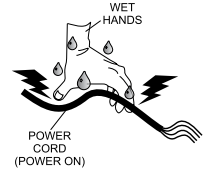

CAUTION

- Ensure that cables and cords will not be tripped over or trapped underneath the mixer.

NOTICE

- **ALWAYS** make certain that the proper power or extension cord has been selected for the job.

TRANSPORTING SAFETY

CAUTION

- **NEVER** allow any person or animal to stand underneath the equipment while lifting.

NOTICE

- **ALWAYS** make sure forklift forks are inserted as far as possible into the pockets (if applicable) when lifting the mixer.
- **ALWAYS** shut down the engine before transporting.
- **NEVER** lift the equipment while the engine is running.
- Tighten the fuel tank cap securely and close the fuel cock to prevent fuel from spilling.
- **DO NOT** lift the machine to unnecessary heights.
- **ALWAYS** tie down equipment during transport by securing the equipment with rope.
- **NEVER** tip the engine to extreme angles during lifting as this may cause oil to gravitate into the cylinder head, making the engine difficult to start.

SAFETY INFORMATION

TOWING SAFETY

CAUTION

- In addition to meeting **Department of Transportation (DOT) safety towing regulations**, check your local county or state safety towing regulations before towing the mixer.
- In order to reduce the possibility of an accident while transporting the mixer on public roads, **ALWAYS** make sure the towing vehicle is mechanically sound and in good operating condition.
- **ALWAYS** shut down the engine before transporting and place the fuel valve in the **OFF** position.
- **ALWAYS** inspect the hitch and coupling for wear. **NEVER** tow a mixer with defective hitches, couplings, chains, etc.
- Check the tire air pressure on both towing vehicle and mixer. **Mixer tires should be inflated to 50 psi cold.** Also check the tire tread wear on the vehicle and mixer.
- **ALWAYS** make sure the mixer is equipped with a **safety chain**.
- **ALWAYS** properly attach the mixer's safety chains to the towing vehicle.
- The maximum speed for highway towing is **55 MPH** unless posted otherwise. Recommended off-road towing is not to exceed **15 MPH** or less depending on type of terrain.
- Avoid sudden stops and starts. These can cause skidding or jackknifing. Smooth, gradual starts and stops will improve towing.
- Avoid sharp turns to prevent rolling.
- The mixer should be adjusted to a level position at all times when towing.
- Raise and lock the mixer wheel stand in the **UP** position when towing.
- Place **chock blocks** underneath the mixer wheels to prevent **rolling** while parked.

ENVIRONMENTAL SAFETY/DECOMMISSIONING

NOTICE

Decommissioning is a controlled process used to safely retire a piece of equipment that is no longer serviceable. If the equipment poses an unacceptable and unrepairable safety risk due to wear or damage or is no longer cost effective to maintain (beyond life-cycle reliability) and is to be decommissioned (demolition and dismantlement), follow the rules below.

- **DO NOT** pour waste or oil directly onto the ground, down a drain or into any water source.
- Contact your country's Department of Public Works or a recycling agency in your area and arrange for proper disposal of any electrical components, waste or oil associated with this equipment. 
- When the life cycle of this equipment is over, remove the battery (if equipped) and bring it to an appropriate facility for lead reclamation. Use safety precautions when handling batteries that contain sulfuric acid.
- When the life cycle of this equipment is over, it is recommended that the mixer frame and all other metal parts be sent to a recycling center.

Metal recycling involves the collection of metal from discarded products and its transformation into raw materials to use in manufacturing a new product.

Recyclers and manufacturers alike promote the process of recycling metal. Using a metal recycling center promotes energy cost savings.

EMISSIONS INFORMATION

NOTICE

The gasoline engine used in this equipment has been designed to reduce harmful levels of carbon monoxide (CO), hydrocarbons (HC) and nitrogen oxides (NOx) contained in gasoline exhaust emissions.

This engine has been certified to meet US EPA evaporative emissions requirements in the installed configuration.

Attempting to modify or make adjustments to the engine emission system by unauthorized personnel without proper training could damage the equipment or create an unsafe condition.

Additionally, modifying the fuel system may adversely affect evaporative emissions, resulting in fines or other penalties.

Emission Control Label

The emission control label is an integral part of the emission system and is strictly controlled by regulation(s).

The label must remain with the engine for its entire life.

If a replacement emission label is needed, please contact your authorized engine distributor.

MIXER SPECIFICATIONS/NOISE AND VIBRATION

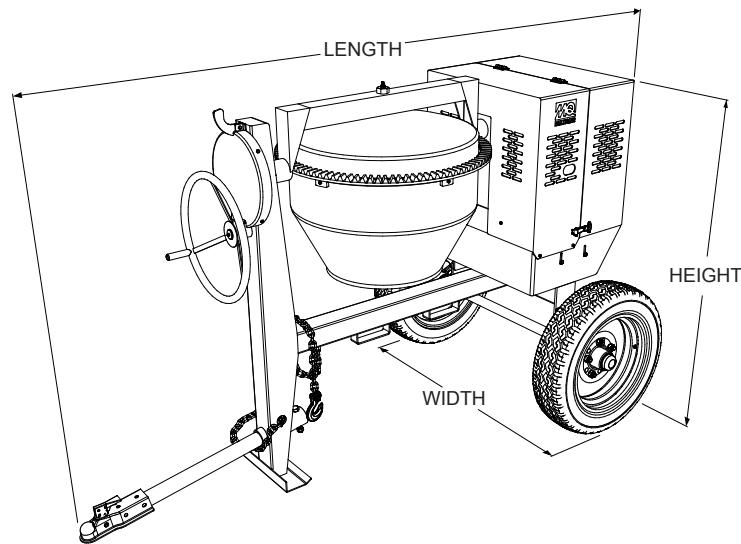

Figure 1. Dimensions

Table 1. MC44S Specifications/Dimensions	
Height	60 in. (1,525 mm)
Width	51 in. (1,296 mm)
Length	66 in. (1,677 mm)
Maximum Mixing Capacity	4 cu. ft. (113 liters)
Bag Capacity	(1/3 to 1/2 bag)
Weight - With Engine/ ElectricMotor	495 lbs. (224 Kg.)

Table 2. MC44S Noise And Vibration (Gasoline)	
Guaranteed ISO 11201:2010 Based Sound Pressure Level at Operator Station in dB(A)	TBD
Guaranteed ISO 3744:2010 Based Sound Power Level in dB(A)	TBD

NOTES:

1. *Sound Pressure and Power Levels are "A" weighted Measures per ISO 226:2003 (ANSI S1.4-1981). They are measured with the operating condition of the machine which generates the most repeatable but highest values of the sound levels. Under normal circumstances, the sound level will vary depending on the condition of the material being worked upon.*
2. *The vibration level indicated is the vector sum of the RMS (Root Mean Square) Values of amplitudes on each axis, standardized to an 8 hour exposure period, and obtained using operating condition of the machine that generates the most repeatable but highest values in accordance with the applicable standards for the machine.*

ENGINE/ELECTRIC MOTOR SPECIFICATIONS

Table 3. Engine/Electric Motor Specifications

Model	HONDA GX120K1QX2/GX120U1QX2 GX120UT1QX2	Baldor 34F324-5596
Type	Air-cooled 4 stroke, Single Cylinder, OHV, Horizontal Shaft Gasoline Engine	1/2 HP, Single-phase 120 VAC, Electric Motor
Bore X Stroke	2.7 in. X 1.7 in. (60 mm x 42 mm)	N/A
Displacement	7.3 cu. in. (119 cc)	N/A
Max Output	3.9 H.P./3,600 rpm	1/2 HP/1725 R.P.M.
Fuel Tank Capacity	0.63 U.S. Gallons (0.60 Liters)	N/A
Fuel	Unleaded Automobile Gasoline	N/A
Lube Oil Capacity	0.63 qt. (0.6 liter)	N/A
Speed Control Method	Centrifugal Fly-weight Type	N/A
Starting Method	Recoil Start	Electric
Input Voltage	N/A	120 VAC Single Phase
Dimension (L x W x H)	11.7 x 13.4 X 12.5 in. (297 X 341 X 318 mm)	13.87 x 7.56 X 8.62 in. (352 X 192 X 219 mm)
Dry Net Weight	28.7 lbs (13.0 Kg.)	Approx. 12 lbs (5.4 kg.)

Table 4. Mixing Hints

Applications	Mix Ratios	Batch Quantities					Approx. Batch Output	
		Cement Bag 112 lb (50 Kg)	Sand		Stone			
			Cu. Ft.	Ltr	Cu. Ft.	Ltr	Cu. Ft.	Ltr
Most Ordinary	1:2:4	1/2 Bag	1¼	35	2½	71	3	85
Foundations	1:3:6	1/3 Bag	1¼	35	2½	71	2¾	78
Rough Mass Concrete	1:4:8	1/4 Bag	1¼	35	2½	71	2¾	78
Watertight Floors, Tanks, Pits, etc.	1:1½:3	2/3 Bag	1¼	35	3	71	3	85

GENERAL INFORMATION

APPLICATION

This mixer is **only** intended for the production of **concrete**. The mixer must be used for its intended purpose and is not suitable for the mixing of **flammable** or **explosive** substances. The mixer **must not be used** in an explosive atmosphere. Use Table 4 (Mixing Hints) as a guide when mixing concrete for various applications.

POWER PLANTS

The mixer can be powered by either a Honda GX120 air-cooled, 4-stroke gasoline engine or a 1/2 HP electric motor. Refer to Table 3 to for specific engine or electric motor data information.

ELECTRICAL

If mixer is equipped with an **electric motor**, make sure that the power being supplied to the motor corresponds to the voltage rating label on the motor. Supplying the wrong voltage to the electric motor will cause severe electrical damage to the motor.

Always make sure the **OFF/ON** switch on the electric motor is in the **OFF** position before applying power.

It is **strongly recommended** when inserting the mixer's power cord into a receptacle, that a G.F.C.I. (**Ground Fault Current Interrupter**) receptacle be used (120 VAC applications).

HARDWARE

Check all hardware on the mixer before starting. Periodically inspect all hardware. Loose hardware can contribute to early component failure and poor performance. Use Table 5 as general guideline when the torqueing of mixer hardware is required. Remember to keep all mixer hardware components tight.

Table 5. Hardware Torque Recommendations

Hardware Diameter	Torque (ft-lbs)
5/16-inch x 18	14
3/8-inch x 16	24
3/8-inch x 24	37
1/2-inch x 13	39
1/2-inch x 13 (Grade 8)	90

ENGINE MAINTENANCE

For basic engine maintenance, refer to the engine maintenance section in this manual. For more detailed engine maintenance, refer to the Honda Engine Owner's manual furnished with the engine.

OPTIONAL TOW BARS

This mixer can be configured for use with various types of tow bars (ball, loop and pin). Reference Figure 2. Contact MQ sales department for the desired tow bar.

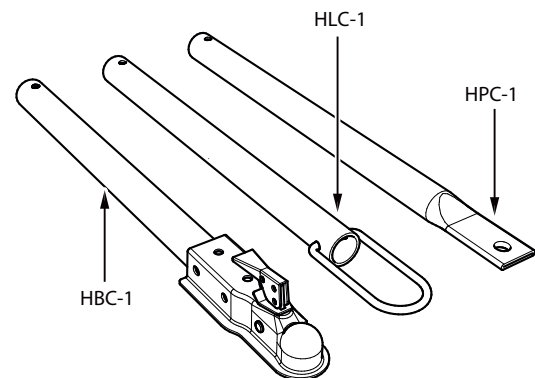

OPTIONAL TOWING BARS

Figure 2. Optional Tow Bars

BASIC COMPONENTS (MIXER)

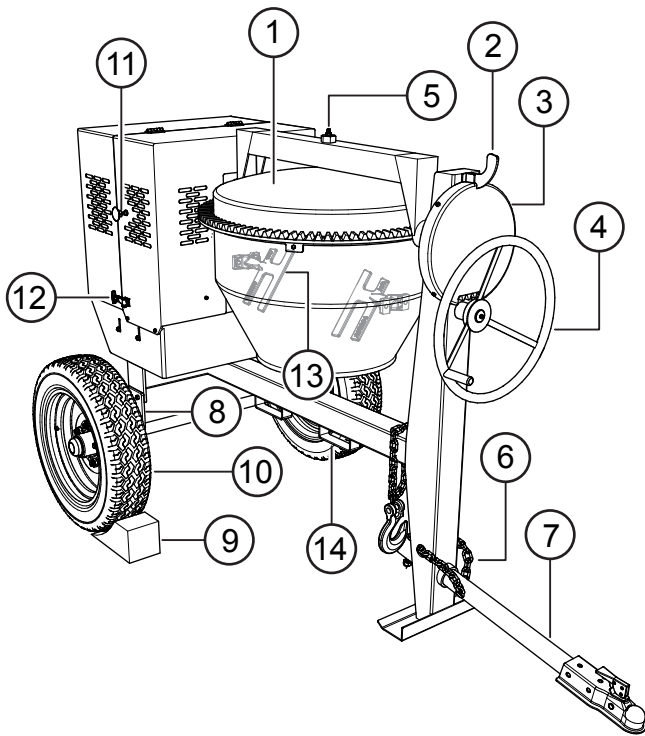

Figure 3. Mixer Major Components

1. **Steel Mixing Drum** — This mixer uses a 4 cu. ft **steel** mixing drum. This drum is to be used for mixing of concrete. Always clean the drum after each use. **DO NOT** use this mixing drum for the mixing of volatile liquids.
2. **Dump Latch** — To rotate the mixing drum, this latch must be in the up position. To lock the drum, place the latch in the down position.
3. **Dump Gear Guard** — **NEVER** operate the mixer with this guard removed. Its purpose is to prevent dirt and debris from entering the dump gear. In addition operator clothing could become entangled in the dump gear, causing severe injury and bodily harm.
4. **Handwheel** — Turn this wheel clockwise or counter-clockwise to rotate the mixing drum. Remember the dump latch must be in the **up position** in order for the mixing drum to be rotated.
5. **Zerk Fittings** — There is, at the bottom and engine side of the **yoke**, and center of the **handwheel** grease zerk fittings. Lubricate these fittings as referenced in the maintenance section of this manual.
6. **Safety Chain** — This mixer uses a 3/16-inch thick, 72-inches long zinc-plated safety chain. **ALWAYS** connect the safety chain when towing.
7. **Tow Bar** — This mixer uses various towing bars, please reference the frame assembly drawing and parts list in this manual to determine which tow bar meets your requirements. inches long zinc-plated safety chain.
8. **Rigid Suspension** — This mixer uses a rigid type suspension. Check the mounting hardware for bolt hole elongation and tightness. See maintenance section of this manual for recommended maintenance.
9. **Chock Blocks** — Place these blocks (not included as part of the mixer package) under each mixer wheel to prevent rolling, when mixer is not connect to the towing vehicle.
10. **Tires Ply** — The tire ply (layers) number is rated in letters; This mixer uses 13-inch 2-ply tires. Replace with only recommended type tires.
11. **ON/OFF Switch (gasoline only)** — This switch is provided on *mixer with gasoline* engines only and is located on the side of the mixer cabinet. When activated it will shut down the engine. Pull out when starting the engine.
12. **Cabinet/Latch** — Encloses engine and electric motor. **NEVER** run mixer with cabinet removed. Use latches to secure engine compartment cabinet.
13. **Mixing Blades (Steel)** — Used for the mixing of concrete. When blades show signs of wear, entire steel mixing drum assembly must be replaced. See steel mixing drum assembly in the parts section of this manual.
14. **Forklift Pockets** — When lifting of the mixer is required, use these fork lift pockets to lift the mixer. Remember to insert the forks of the forklift a minimum of 24 inches into the lift pockets.

ENGINE COMPONENTS

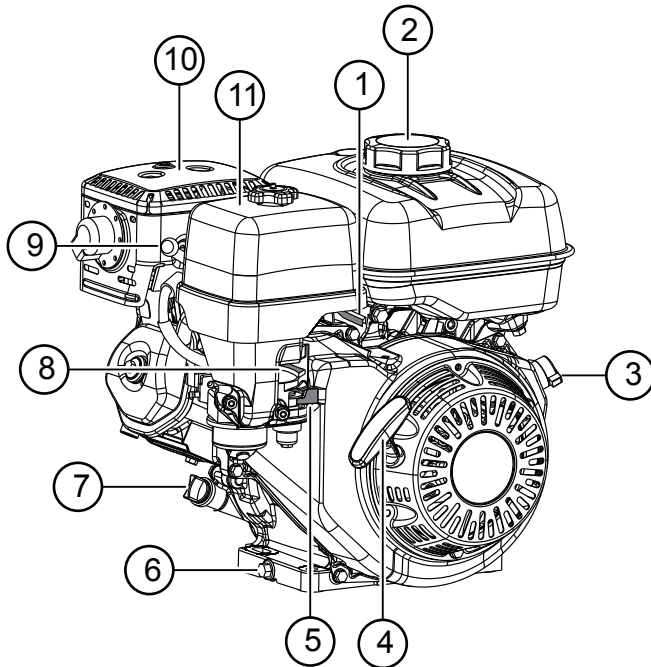

Figure 4. Engine Components

INITIAL SERVICING

The engine (Figure 4) must be checked for proper lubrication and filled with fuel prior to operation. Refer to the manufacturer's engine manual for instructions and details of operation and servicing.

1. **Throttle Lever** – Used to adjust engine RPM speed.
2. **Fuel Filler Cap/Fuel Tank** – Remove this cap to add unleaded gasoline to the fuel tank. Fill with unleaded gasoline. Refer to Table 3 for fuel tank capacity. Make sure cap is tightened securely. **DO NOT** over fill. For additional information refer to Honda engine owner's manual.

DANGER



Add fuel to the tank only when the engine is stopped and has had an opportunity to cool down. In the event of a fuel spill, **DO NOT** attempt to start the engine until the fuel residue has been completely wiped up and the area surrounding the engine is dry.

3. **Engine On/Off Switch** – **ON** position permits engine starting, **OFF** position stops engine operation.
4. **Recoil Starter (pull rope)** – Manual-starting method. Pull the starter grip until resistance is felt, then pull briskly and smoothly.
5. **Fuel Valve Lever** – **OPEN** to let fuel flow, **CLOSE** to stop the flow of fuel.
6. **Oil Drain Plug** – Remove this plug to remove oil from the engine's crankcase.
7. **Dipstick/Oil Filler Cap** – Remove this cap to determine if the engine oil is low. Add oil through this filler port as recommended in Table 6.
8. **Choke Lever** – Used in the starting of a cold engine, or in cold weather conditions. The choke enriches the fuel mixture.
9. **Spark Plug** – Provides spark to the ignition system. Set spark plug gap according to engine manufacturer's instructions. Clean spark plug once a week.
10. **Muffler** – Used to reduce noise and emissions. **NEVER** touch when *hot!*
11. **Air Cleaner** – Prevents dirt and other debris from entering the fuel system. Remove wing-nut on top of air filter canister to gain access to filter element.

NOTICE

Operating the engine without an air filter, with a damaged air filter, or a filter in need of replacement will allow dirt to enter the engine, causing rapid engine wear.

ELECTRIC MOTOR COMPONENTS

ELECTRIC MOTOR

For lubrication care and operation of the electric motor, refer to your electric motor instruction booklet furnished with the motor.

Protect the electric motor from dust as much as possible and keep ventilating openings clean.

CAUTION

DO NOT spray water at any time on the electric motor.
DO NOT operate electric motor in an explosive environment.

The electric motor used on this mixer is single-phase, 1/2 HP @120 VAC motor. Pay special attention to the nameplate on the electric motor when supplying power to the electric motor. Applying incorrect power to the motor can severely damage the motor and **may cause serious bodily injury!**

Always make certain that the correct voltage is being supplied to the motor. The input voltage requirements can be found on the electric motor's nameplate.

ELECTRIC MOTOR POWER CONNECTIONS

A 12-inch electrical cable (Figure 5) is provided with the electrical motor for hookup to a power source.

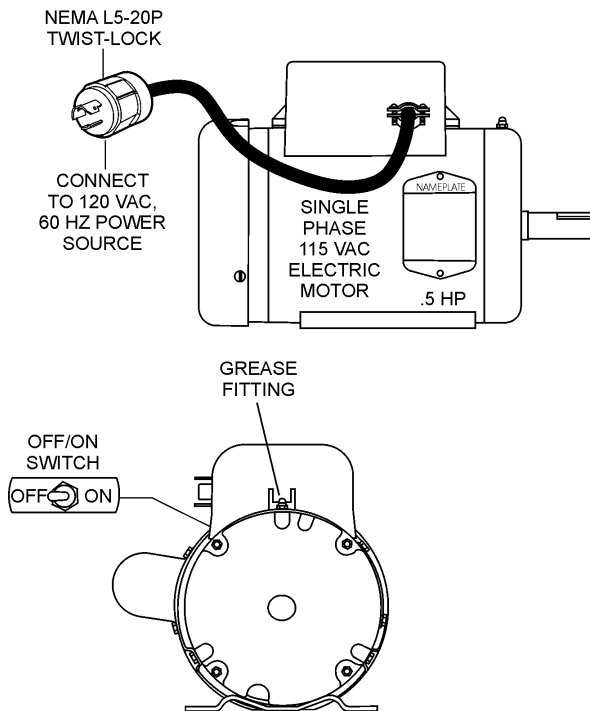

Figure 5. Electric Motor

The electric motor supplied with the mixer is configured from the factory for 120 VAC grounded operation.

Motors can burn out when the line voltage falls 10% below the voltage rating of the motor. Failure to use proper voltage will cause the motor to overheat and actuate the overload switch.

If overload protection should actuate because of improper voltage or any other malfunction, turn the main switch on the motor to the "OFF" position and correct the problem, press the reset switch button, and turn the main switch to the "ON" position.

NOTICE

It is strongly recommended that all electrical wiring be done by a **licensed electrician**. Pay special attention to the nameplate on the electric motor. Make certain that the voltage supplied to the electric motor matches the required operating voltage printed on the nameplate.

NOTICE

ALWAYS make certain the electric motor's **ON/OFF** switch is working properly. When the mixer is not in use, place the **ON/OFF** switch in the "OFF" position and disconnect the power cord from the power source.

CAUTION

NEVER disable or disconnect the **ON/OFF** switch on the electric motor. It is provided for operator safety. Injury may result if it is disabled, disconnected or improperly maintained.

TOWING GUIDELINES

TOWING SAFETY PRECAUTIONS

CAUTION

Check with your county or state safety towing regulations department before towing your *mixer*.

To reduce the possibility of an accident while transporting the mixer on public roads, always make sure that the mixer towing components and the towing vehicle are in good operating condition and both units are mechanically sound.

The following list of suggestions should be used when towing the mixer:

- Make sure that the hitch and coupling of the towing vehicle are rated equal to, or greater than the trailer "gross vehicle weight rating" (GVWR).
- **ALWAYS** inspect the hitch and coupling for wear. **NEVER** tow the mixer with defective hitches, couplings, chains etc.
- **CHECK** the tire air pressure on both the towing vehicle and the trailer. Also check the tire tread wear on both vehicles.
- **ALWAYS** make sure the mixer is equipped with a "Safety Chain."
- **ALWAYS** attach trailer's safety chain to the frame of towing vehicle.
- **ALWAYS** make sure that the towing vehicle's directional, backup, and brake lights are working properly.
- Remember in most cases the maximum speed unless otherwise posted for highway towing is **55 MPH**, however before towing your mixer, check your local state, and county vehicle towing requirements. Recommended off-road towing is not to exceed **15 MPH** or less depending on type of terrain.
- Place **chocked blocks** underneath wheels to prevent **rolling**, while parked, if disconnected from towing vehicle.
- Inflate tires to correct pressure, inspect tires for cuts, and excessive wear. See Table 9 (Tire Wear Troubleshooting).
- When towing of the mixer is required, place the drum in the up position (mouth facing upwards).

- **ALWAYS** make sure that the fuel valve lever is in the **OFF** position (gasoline models only).
- Check wheel mounting lug nuts with a torque wrench. Torque wheel lug nuts as described in the maintenance section of this manual.
- Check tightness of U-clamp nuts, torque suspension hardware as referenced in the maintenance section of this manual.
- Avoid sudden stops and starts. This can cause skidding, or jackknifing. Smooth, gradual starts and stops will improve gas mileage.
- Avoid sharp turns to prevent rolling.

CAUTION

If the mixer tow bar is deformed or damaged replace entire tow bar. **NEVER** tow the mixer with a defective tow bar. There exist the possibility of the trailer separating from the **towing vehicle**.

TOW BAR TO VEHICLE (COUPLER ONLY)

1. Check the vehicle hitch ball, and mixer's coupler for signs of wear or damage. Replace any parts that are worn or damaged before towing.
2. Use only a 2-inch ball diameter (towing vehicle), this will match the mixer's 2-inch coupler. Use of any other ball diameter will create an extremely dangerous condition which can result in separation of the coupler and ball or ball failure.
3. After tow bar has been connected to mixer (see next page), attach mixer's coupler to the hitch ball on the towing vehicle securely and make sure the lock lever is in the down position (locked).

MIXER TOW BAR VEHICLE (PINTLE AND LOOP)

1. Make sure the bumper on the towing vehicle is equipped to handle either a pintle or loop type tow bar configuration.
2. After tow bar has been connected to mixer (see next page), secure either type of tow bar to the towing vehicle, following state and county towing regulations
3. As a minimum, use a 1/2-inch bolt and nylock nut grade 5 when securing either tow bar to the towing vehicle.

SAFETY CHAIN CONNECTION

CAUTION

NEVER tow the mixer with the safety chain removed. The safety chain is intended to prevent complete separation of the mixer from the towing vehicle in the event of a tow bar failure.

TOW BAR TO MIXER CONNECTION

1. Insert the tow bar through the round opening at the bottom of the mixer stand (Figure 6).

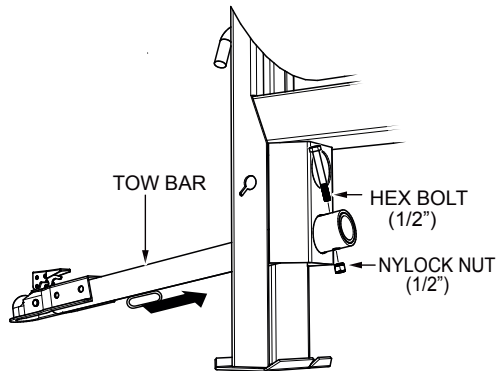

Figure 6. Inserting Tow Bar

2. Align the hole on the tow bar with the hole on the mixer frame (Figure 6), and insert 1/2-inch bolt through tow bar and frame. Secure tow bar to frame with 1/2-inch nylock nut. Tighten to 40 ft.-lbs.
3. Route the safety chain through the holes just above the tow bar, located on each side of the mixer stand.

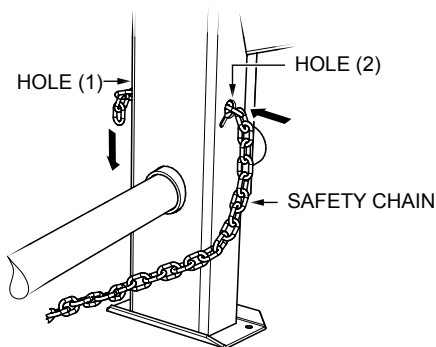

Figure 7. Attaching Safety Chains to Mixer Stand

4. Loop (cross) the safety chain (Figure 8) and place under the tow bar. Secure the loop with the safety chain connector link.

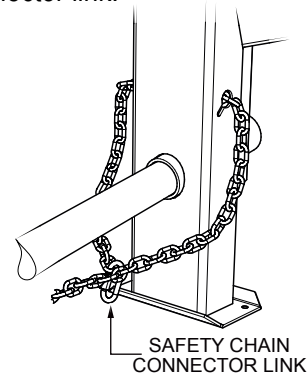

Figure 8. Crossing The Safety Chain

5. Extend the safety chain along the length of the tow bar (Figure 9), looping it through the tow bar's connector link. Remove any excess chain slack.

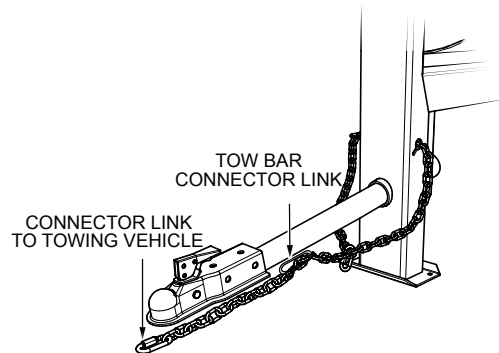

Figure 9. Extending Safety Chain

6. Connect the free end of (connector link) the safety chain to the towing vehicle (Figure 9). Remember it is critical that the length of the chain be properly adjusted, to prevent the draw bar and the front of the mixer stand from dropping to the the ground (contact) in the event the draw bar becomes disconnected from the towing vehicle.

BEFORE STARTING

1. Read all safety instructions at the beginning of manual.
2. Clean the unit, removing dirt and dust, particularly the engine cooling air inlet, carburetor and air cleaner.
3. Check the air filter for dirt and dust. If air filter is dirty, replace air filter with a new one as required.
4. Check carburetor for external dirt and dust. Clean with dry compressed air.
5. Check fastening nuts and bolts for tightness.

CAUTION



ALWAYS wear approved eye and hearing protection while operating the mixer.

CAUTION



NEVER place hands or feet inside the engine guard cover while the engine is running. **ALWAYS** shut the engine down before performing any kind of maintenance service on the mixer.

ENGINE OIL CHECK

1. To check the engine oil level, place the unit on secure level ground with the engine stopped.
2. Remove the filler dipstick from the engine oil filler hole (Figure 10) and wipe it clean.

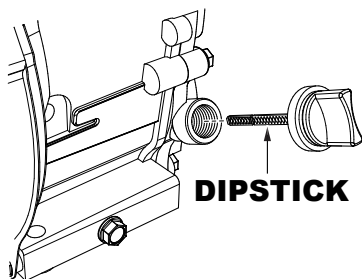

Figure 10. Engine Oil Dipstick (Removal)

3. Insert and remove the dipstick without screwing it into the filler neck. Check the oil level shown on the dipstick.
4. If the oil level is low (Figure 11), fill to the edge of the oil filler hole with the recommended oil type (Table 6). Maximum oil capacity is 2.33 pints (1.09 liters).

NOTICE

Reference engine manufacturer's manual for specific servicing instructions.

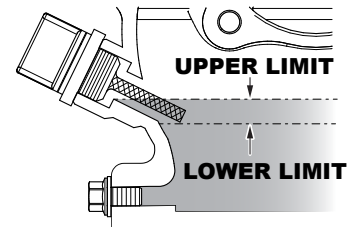

Figure 11. Engine Oil Dipstick (Oil Level)

Table 6. Engine Oil Type

Season	Temperature	Oil Type
Summer	25°C or Higher	SAE 10W-30
Spring/Fall	25°C ~ 10°C	SAE 10W-30/20
Winter	0°C or Lower	SAE 10W-10

FUEL CHECK

DANGER



If your mixer has a gasoline engine, determine if the engine fuel is low. If fuel is low, remove the fuel filler cap and fill it with **unleaded** gasoline. Motor fuels are **highly flammable** and can be dangerous if mishandled. **DO NOT** smoke while refueling. **DO NOT** attempt to refuel the mixer if the engine is **hot** or **running**.

CAUTION

NEVER disable or disconnect the **start/stop switch**. It is provided for operator safety. Injury may result if it is disabled, disconnected or improperly maintained.

1. Remove the gasoline cap located on top of fuel tank.
2. Visually inspect to see if fuel level is low. If fuel is low, replenish with unleaded fuel.
3. When refueling, be sure to use a strainer for filtration. **DO NOT** top-off fuel. Wipe up any spilled fuel immediately.

TIRES

Check for **worn** or **defective** tires (Figure 12). Replace any defective or worn tires immediately.

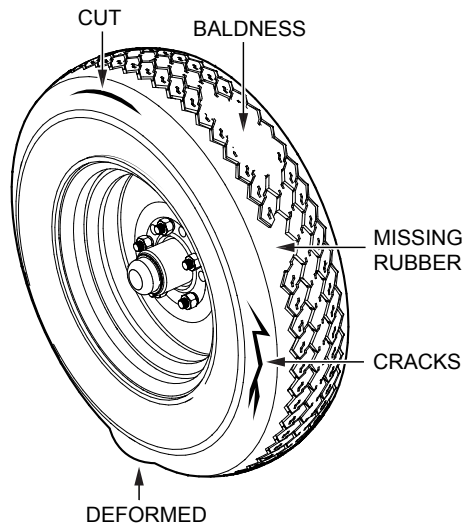

Figure 12. Tire Wear

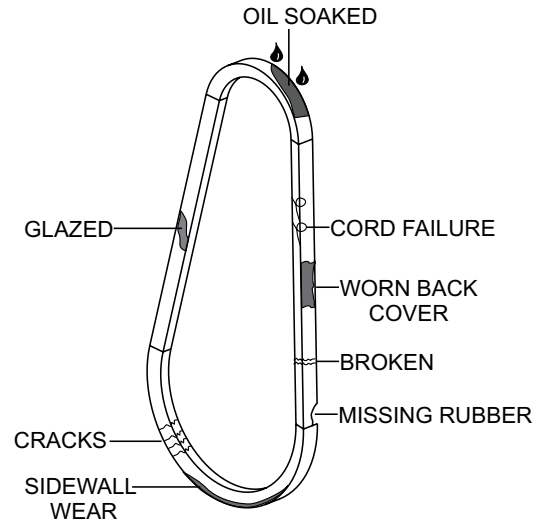

Figure 13. V-Belt Inspection

V-BELT CHECK

Visually examine the V-belt (Figure 13) and determine if it is full of tiny cracks, frayed, has pieces of rubber missing, is peeling or otherwise damaged.

Also, examine the belt and determine if it is **oil soaked** or "**glazed**" (hard shiny appearance on the sides of the belt). Either of these two conditions can cause the belt to run hot, which can weaken it and increase the danger of it breaking.

If the V-belt exhibits any of the above wear conditions replace the V-belt immediately.

START-UP

This section is intended to assist the operator with the initial start-up of the unit. It is extremely important that this section be read carefully before attempting to use the mixer in the field. **DO NOT** use your mixer until this section is thoroughly understood.



WARNING

Failure to understand the operation of the mixer could result in severe damage to the mixer or personal injury. Reference Figure 3 and Figure 4 for the location of any components referenced in this manual.

CAUTION



NEVER operate the mixer in a confined area or enclosed area structure that does not provide ample free flow of air.

STARTING THE MIXER (GASOLINE ENGINE)

The following steps outline the procedure for starting the engine.

1. Place the fuel shut-off lever (Figure 14) in the **ON** position.

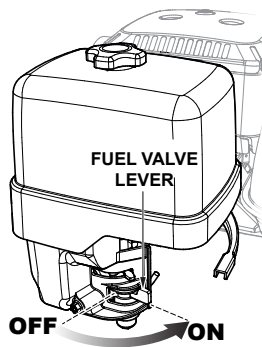

Figure 14. Fuel Shut-Off Lever

2. To start a cold engine, move the choke lever (Figure 15) to the **CLOSED** position.

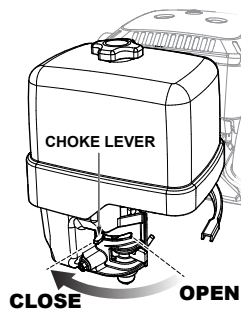

Figure 15. Choke Lever

3. Move the throttle lever (Figure 16) away from the slow position, about 1/3 of the way toward the fast position.

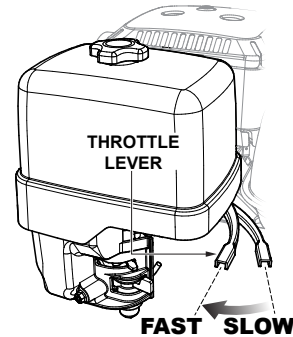

Figure 16. Throttle Lever

4. Turn the engine switch (Figure 17) to the **ON** position.

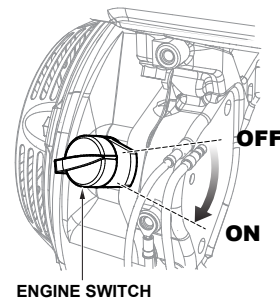

Figure 17. Engine On/Off Switch

5. Located at the rear of the mixer frame is the main **start/stop** button (Figure 18). Pull this button outward to start the engine.

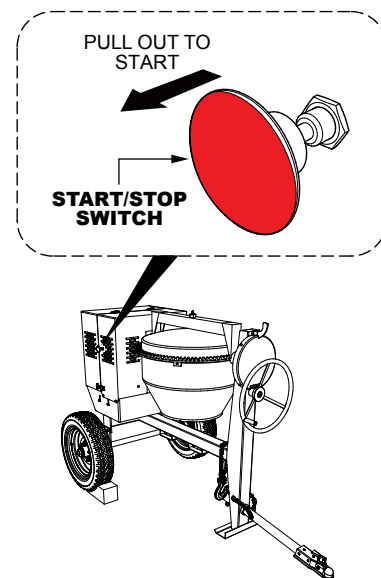
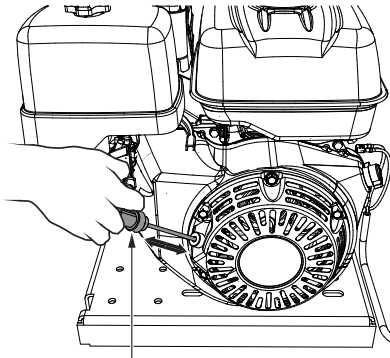

Figure 18. Engine Start/Stop Button

6. Pull the **starter grip** (Figure 19) lightly until you feel resistance, then pull briskly. Return the starter grip gently.



STARTER GRIP

Figure 19. Starter Grip

STARTING THE MIXER (ELECTRIC MOTOR)

The following steps outline the procedure for starting the electric motor.

1. Using an adequate size extension cord (Table 7), connect one end of the extension cord to the plug on the electric motor, connect the other end to the power source. Make sure the motor is configured for the proper operating voltage.

Table 7. Cable Selection (60 Hz, Single Phase Operation)					
Current in Amperes	Load in Watts	Maximum Allowable Cable Length			
	At 120 Volts	#10 Wire	#12 Wire	#14 Wire	#16 Wire
2.5	300	1000 ft.	600 ft.	375 ft.	250 ft.
5	600	500 ft.	300 ft.	200 ft.	125 ft.
7.5	900	350 ft.	200 ft.	125 ft.	100 ft.
10	1200	250 ft.	150 ft.	100 ft.	
15	1800	150 ft.	100 ft.	65 ft.	
20	2400	125 ft.	75 ft.	50 ft.	

CAUTION: Equipment damage can result from low voltage

NOTICE

Extensions cords must be rated "Heavy Duty" or "Extra Heavy Duty" and must be a continuous length.

2. To start the electric motor, move the **ON/OFF** switch to the ON position (Figure 20).

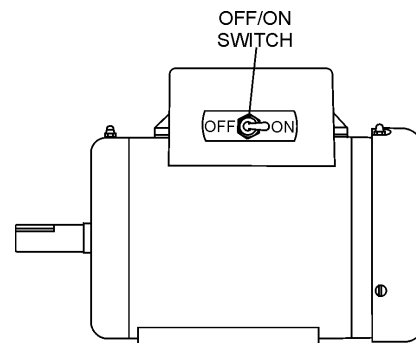

Figure 20. Electric Motor ON/OFF Switch

MIXING

1. To position the tub, make sure the mixer is placed on firm level ground, then pull up on the dump latch (Figure 21) and turn the hand wheel until the tub is at the desired position. Once the tub is at the desired position, pull down on the dump latch to lock the tub in position.

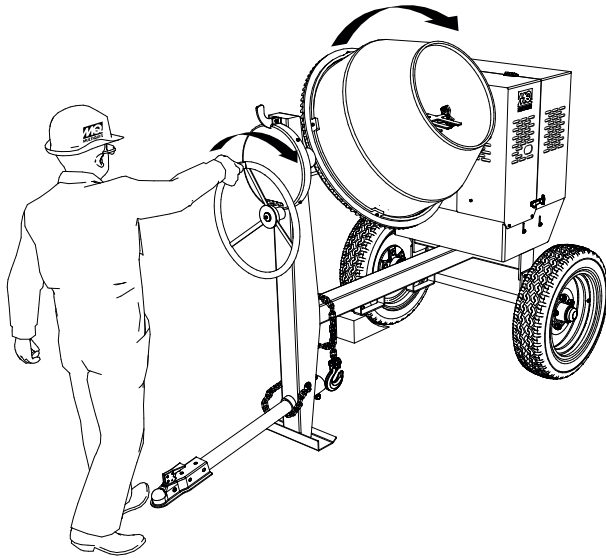

Figure 21. Mixing Drum Positioning

CAUTION

NEVER stand in front or behind the mixing drum while it is being placed in the dump position. Stay clear of the mixing drum while it is being positioned.

2. As the drum rotates, use a shovel (Figure 22) to place the cement mix inside the drum, add water as required. Be careful to only place the tip of the shovel inside the drum.

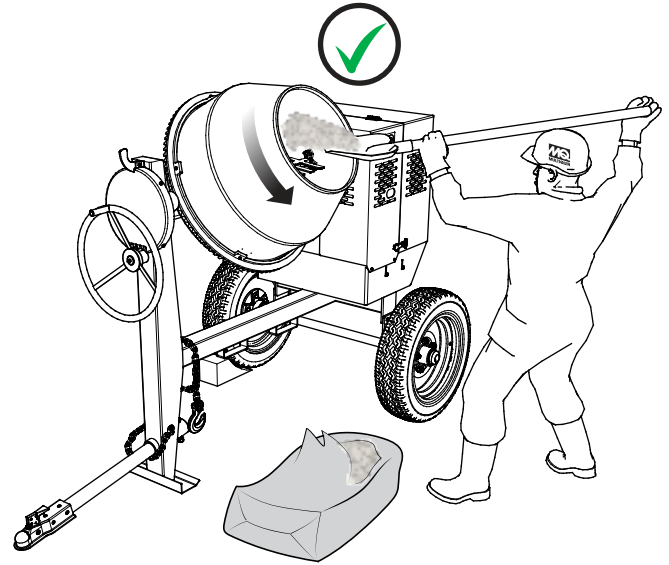

Figure 22. Filling Mixing Drum (CORRECT)

3. Placing the shovel all the way inside the drum (Figure 23) will cause the shovel to strike the blades. This condition will make the shovel rotate, and could cause injury to personnel. **NEVER** place hands inside the mixing drum while it is rotating.

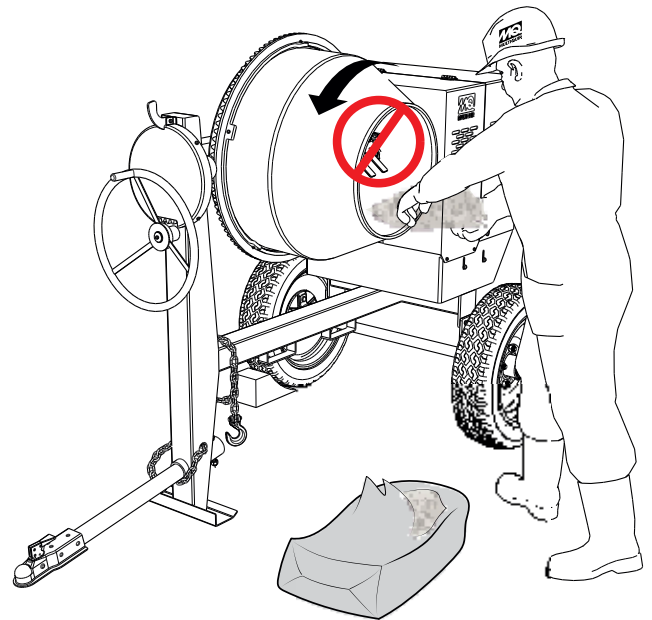

Figure 23. Filling Mixing Drum (WRONG)

STOPPING THE MIXER (GASOLINE ENGINE)

1. Place the throttle lever (Figure 24) in the slow (idle) position, and let the engine idle 3~5 minutes.

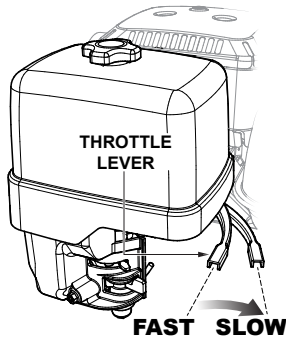

Figure 24. Throttle Lever (Idle)

2. Push the engine **start/stop** switch (Figure 25) inward to stop the engine.

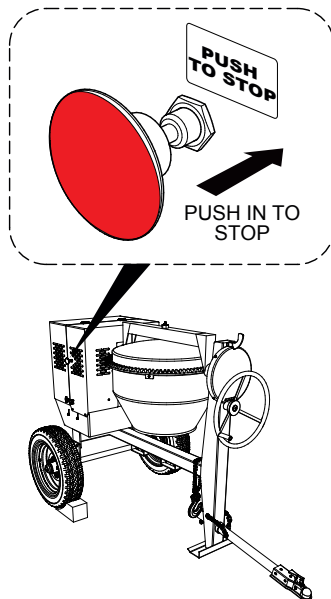

Figure 25. Start/Stop Button (Stop Position)

3. Place fuel shut-off lever (Figure 14) in the **OFF** position.

STOPPING THE MIXER (ELECTRIC MOTOR)

1. To stop the electric motor, move the **ON/OFF** switch to the **OFF** position (Figure 26).

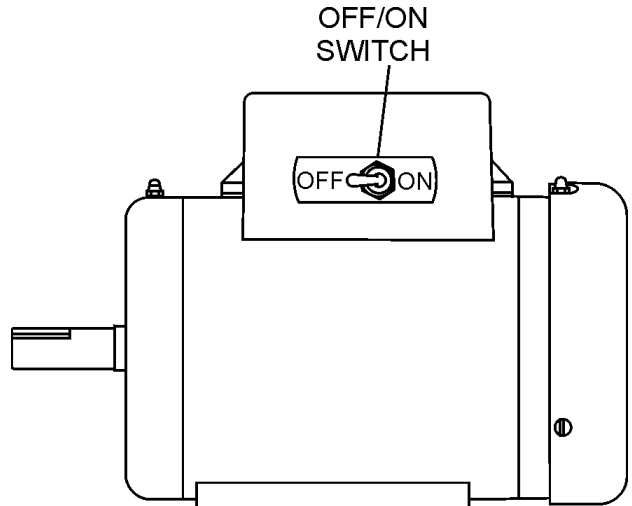

Figure 26. Electric Motor OFF/STOP Switch

2. Remove extension cord from electric motor plug.
3. Place fuel shut-off lever (Figure 14) in the **OFF** position.

MAINTENANCE (ENGINE)

Use Table 8 as a general maintenance guideline when servicing your engine. For more detail engine maintenance information, refer to the engine owner's manual supplied with your engine.

Table 8. Engine Maintenance Schedule

DESCRIPTION (3)	OPERATION	BEFORE	FIRST MONTH OR 10 HRS.	EVERY 3 MONTHS OR 25 HRS.	EVERY 6 MONTHS OR 50 HRS.	EVERY YEAR OR 100 HRS.	EVERY 2 YEARS OR 200 HRS.
Engine Oil	Check	X					
	Change		X				
Air Cleaner	Check	X					
	Change			X (1)			
All Nuts and Bolts	Re-tighten if necessary	X					
Spark Plugs	Check/Clean				X		
	Replace						X
Cooling Fins	Check				X		
Spark Arrester	Clean					X	
Fuel Tank	Clean					X	
Fuel Filter	Check					X	
Idle Speed	Check/ Adjust					X (2)	
Valve Clearance	Check/ Adjust						X (2)
Fuel Lines	Check	Every 2 years (replace if necessary) (2)					

(1) Service more frequently when used in **DUSTY** areas.

(2) These items should be serviced by your service dealer, unless you have the proper tools and are mechanically proficient. Refer to the HONDA Shop Manual for service procedures.

(3) For commercial use, log hours of operation to determine proper maintenance intervals.

MAINTENANCE (ENGINE)

MAINTENANCE

Perform the scheduled maintenance procedures as defined by Table 8 and below:

DAILY

AIR CLEANER/ FASTENERS

Thoroughly remove dirt and oil from the engine and control area. Clean or replace the air cleaner elements as necessary. Check and retighten all fasteners as necessary.

WIRING

Inspect the entire mixer for bad or worn electrical wiring or connections. If any wiring or connections are exposed (insulation missing) replace wiring immediately.

PIPING AND HOSE CONNECTION

Inspect all piping, oil hose, hydraulic hose and fuel hose connections for wear and tightness. Tighten all hose clamps and check for leaks. If any hose lines are defective replace them immediately.

WEEKLY

FUEL STRAINER (IF EQUIPPED)

1. Thoroughly clean the area around the fuel cap.
2. Remove the fuel cap from the fuel tank.
3. Next, remove, inspect and clean the fuel strainer (Figure 27) with solvent.

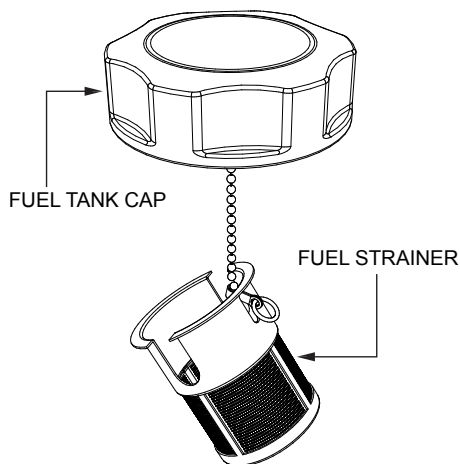

Figure 27. Fuel Strainer

SPARK PLUG

1. Remove and clean the spark plug (Figure 28), then adjust the spark gap to 0.024 ~0.028 inch (0.6~0.7 mm). This unit has electronic ignition, which requires no adjustments.

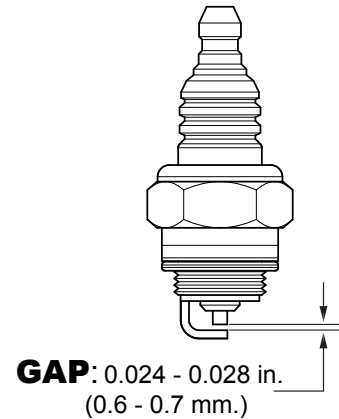

Figure 28. Spark Plug Gap

ENGINE OIL

1. Drain the engine oil when the oil is warm as shown in Figure 29.
2. Unscrew the oil filler dipstick from its holder.
3. Next, remove oil drain bolt and sealing washer and allow the oil to drain into a suitable container.
4. Replace engine oil with recommended type oil as listed in Table 6. For engine oil capacity, see Table 3 (Engine Specifications). **DO NOT** overfill.
5. Install drain bolt with sealing washer and tighten securely.

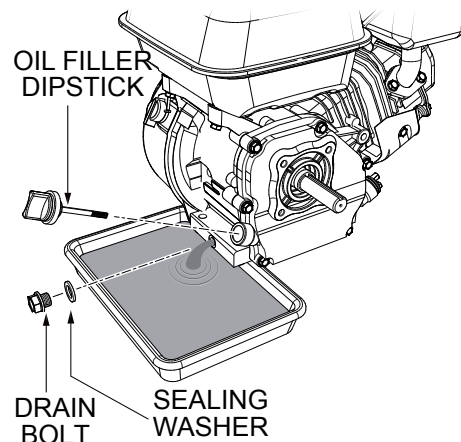

Figure 29. Draining Engine Oil

MAINTENANCE (ENGINE)

ENGINE AIR CLEANER

1. Remove the air cleaner cover and foam filter element as shown in Figure 30.
2. Tap the paper filter element (Figure 30) several times on a hard surface to remove dirt, or blow compressed air [not exceeding 30 psi (207 kPa, 2.1 kgf/cm²)] through the filter element from the air cleaner case side. **NEVER** brush off dirt. Brushing will force dirt into the fibers. Replace the paper filter element if it is excessively dirty.
3. Clean foam element in warm, soapy water or nonflammable solvent. Rinse and dry thoroughly. Dip the element in clean engine oil and completely squeeze out the excess oil from the element before installing.

DANGER

DO NOT use gasoline as a cleaning solvent to avoid creating the risk of fire or an explosion.

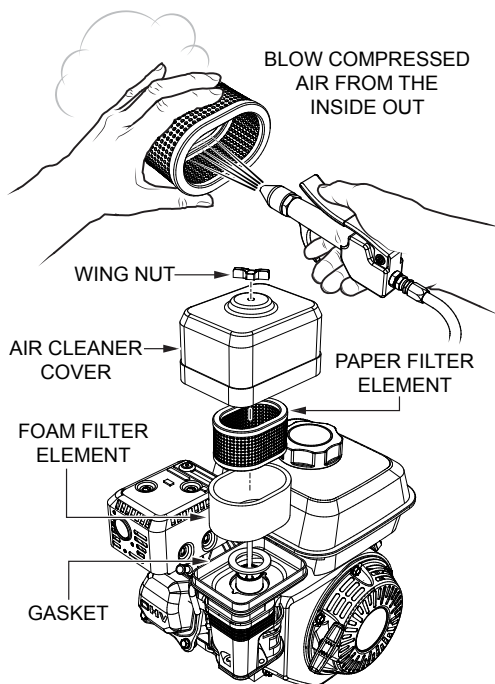

Figure 30. Engine Air Cleaner

SPARK ARRESTER CLEANING

Clean the spark arrester every 6 months or 100 hours.

1. Remove the 4 mm screw (3) from the exhaust deflector (Figure 31), then remove the deflector.

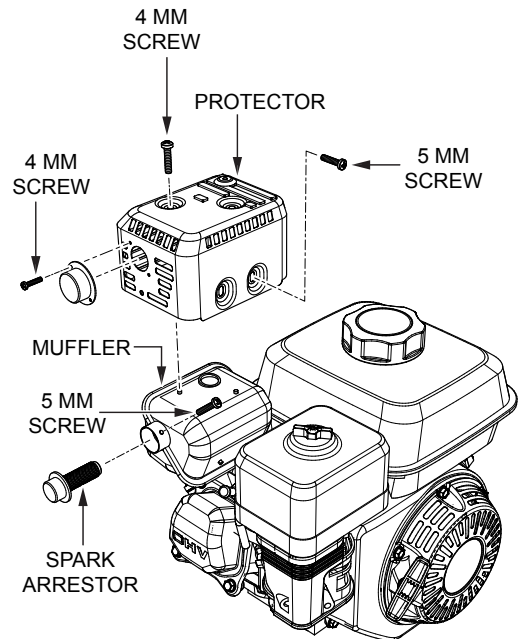

Figure 31. Spark Arrester

2. Remove the 5 mm screw (4) from the muffler protector, then remove the muffler protector.
3. Carefully remove carbon deposits from the spark arrester screen (Figure 32) with a wire brush

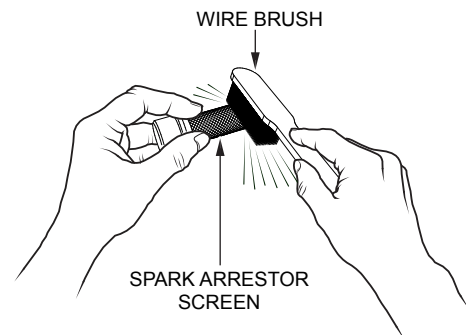

Figure 32. Cleaning The Spark Arrester

4. If the spark arrester is damaged and has breaks or holes, replace with a new one.
5. Reinstall the spark arrester and muffler protector in reverse order of disassembly.

MAINTENANCE (MIXER)

BALL SOCKET AND CLAMP FACE

1. If the towing vehicle is equipped with a ball socket, smear socket periodically with multi-purpose grease. This will keep the ball socket well lubricated.
2. Periodically oil **pivot points** and **clamp face** surfaces of coupler with SAE 30 WT. motor oil.
3. When parking or storing your mixer. Keep the coupler off the ground so dirt will not build up in the ball socket.

GREASE FITTINGS (ZERK) - MIXER

1. There are 3 grease (Figure 33) fittings that will require lubrication. Lubricate these fittings **once a week**. Use lithium base grease, grade No.1.

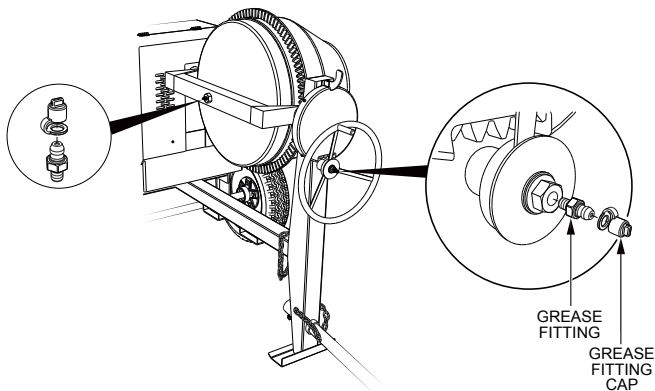

Figure 33. Grease Fittings (Mixer)

GREASE FITTINGS (ZERK) - ELECTRIC MOTOR

1. There are two grease (Figure 34) fittings at each end of the electric motor that will require lubrication. Lubricate these fittings about **every 16 months**.

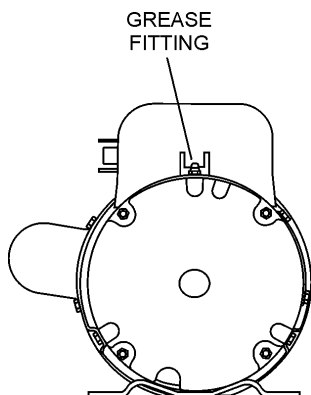

Figure 34. Grease Fittings (Electric Motor)

2. Use Poleyrex EM (Exxon Mobil) or equivalent lubricant. Clean grease fitting, apply grease gun to fitting (1/2 shot). Remember too much grease or injecting grease too quickly can cause premature bearing failure. Slowly apply the recommended amount of grease, taking a minute or so to apply.

WHEEL BEARINGS

1. After **every 3 months** of operation, remove the hub dust cap and inspect the wheel bearings (Figure 35). Once a year, or when required, disassemble the wheel hubs remove the old grease and repack the bearings forcing grease between rollers, cone and cage with a good grade of high speed wheel bearing grease (never use grease heavier than 265 A.S.T.M. penetration ("No. 2.")).

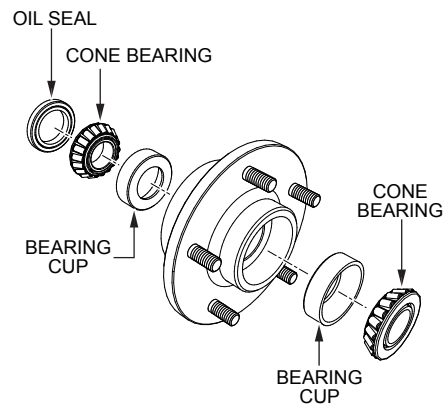

Figure 35. Wheel Hub and Bearings

2. Fill the wheel hub (Figure 35) with grease to the inside diameter of the outer races and also fill the hub grease cap. Reassemble the hub and mount the wheel. Then tighten the adjusting nut, at the same time turn the wheel in both directions, until there is a slight bind to be sure all the bearing surfaces are in contact.

Then back-off the adjusting nut 1/6 to 1/4 turn or to the nearest locking hole or sufficiently to allow the wheel to rotate freely within limits of .001" to .010" end play. Lock the nut at this position. Install the cotter pin and dust cap, and tighten all hardware.

MAINTENANCE (MIXER)

MIXER CLEANING

It is important that the drum interior is free of dried material. Obstructions can cause the paddle blades to lock against the drum.

1. Push the “**Engine Stop**” button inward to the **OFF** position to stop the engine.
2. **ALWAYS disconnect the spark plug wire** (gasoline engines) before cleaning the inside of the drum. If mixer is equipped with an electric motor **remove power cord from AC power source**. In addition make sure the clutch engagement lever is **disengaged**.
3. Place “**Do Not Operate**” tag on mixer.
4. At the end of each day’s operation, place mixer drum in an upright position and spray inside of tub immediately with water to prevent lumps of dried mortar or plaster from forming and contamination of future batches.
5. **DO NOT** allow a buildup of materials to form on the blades or anywhere inside the drum.
6. Rotate mixer to **dump** position and remove debris.
7. **Thoroughly clean** the entire mixer, wheels, cabinet and frame.
8. **NEVER!** pour or spray water over the engine or electric motor (Figure 36).

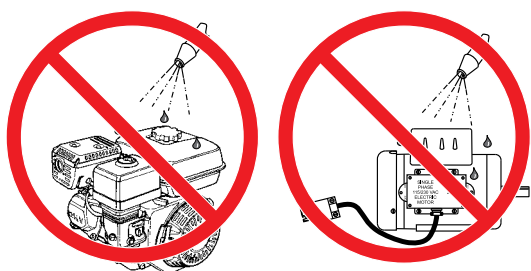

Figure 36. No Spraying of Water

9. When cleaning of the entire mixer is done, return mixing drum to an upright position.

TIRES/WHEELS/LUG NUTS

Tires and wheels are a very important and critical components of the trailer. When specifying or replacing the trailer wheels it is important the wheels, tires, and axle are properly matched.

WARNING



DO NOT attempt to repair or modify a wheel. **DO NOT** install an inter-tube to correct a leak through the rim. If the rim is cracked, the air pressure in the inter-tube may cause pieces of the rim to explode (break-off) with great force and can cause serious eye or bodily injury.

Tires Wear/Inflation







Tire inflation pressure is the most important factor in tire life. Pressure should be checked cold before operation. **DO NOT** bleed air from tires when they are hot. Check inflation pressure weekly during use to insure the maximum tire life and tread wear.

WARNING



ALWAYS wear safety glasses when removing or installing force fitted parts. Failure to comply may result in serious injury.

Table 9 (Tire Wear Troubleshooting) will help pinpoint the causes and solutions of tire wear problems.

Table 9. Tire Wear Troubleshooting			
Wear Pattern		Cause	Solution
	Center Wear	Over Inflation	Adjust pressure to particular load per tire manufacturer
	Edge Wear	Under Inflation	Adjust pressure to particular load per tire manufacturer.
	Side Wear	Loss of chamber or overloading	Make sure load does not exceed axle rating. Align wheels.
	Toe Wear	Incorrect toe-in	Align wheels.
	Cupping	Out of balance	Check bearing adjustment and balance tires.
	Flat Spots	Wheel lockup and tire skidding	Avoid sudden stops when possible and adjust brakes.

MAINTENANCE (MIXER)

SUSPENSION

The rigid suspension and associated components (Figure 37) should be visually inspected every 6,000 miles for signs of excessive wear, elongation of bolt holes, and loosening of mounting bracket. Replace any damaged suspension component immediately.

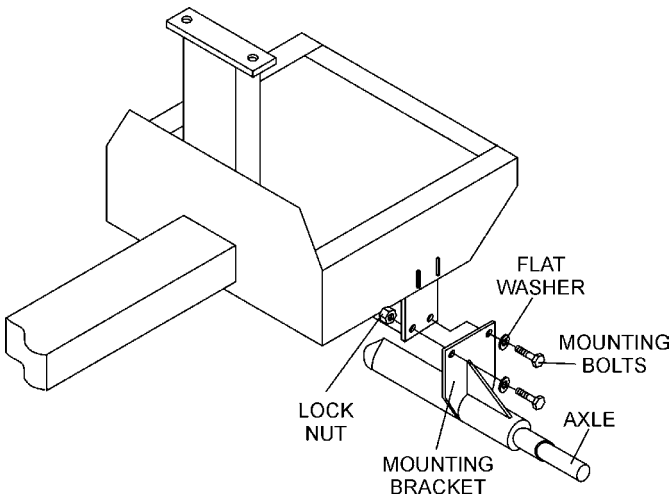

Figure 37. Suspension Components

LUG NUT TORQUE REQUIREMENTS

It is extremely important to apply and maintain proper wheel mounting torque. Be sure to use only the fasteners matched to the cone angle of the wheel. Proper procedure for attachment of the wheels is as follows:

1. Start all wheel lug nuts by hand.
2. Torque all lug nuts in sequence. See Figure 38. **DO NOT** torque the wheel lug nuts all the way down. Tighten (torque) each lug nut in 3 separate passes as defined by Table 10.

NOTICE

NEVER use an pneumatic air gun to tighten wheel lug nuts.

3. After first road use, retorque all lug nuts in sequence. Check all wheel lug nuts periodically.

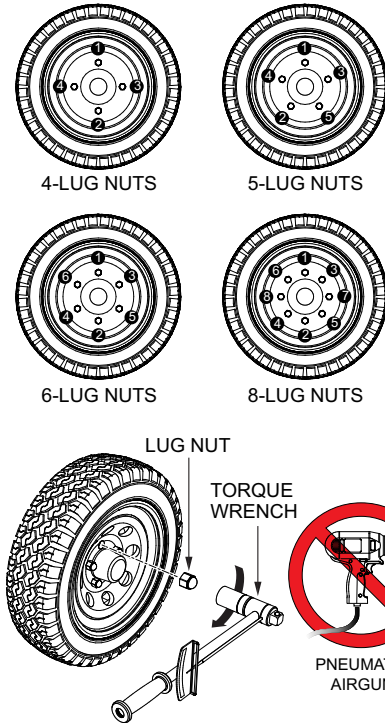

Figure 38. Wheel Lug Nuts Tightening Sequence

Table 10. Tire Torque Requirements

Wheel Size	First Pass FT-LBS	Second Pass FT-LBS	Third Pass FT-LBS
12"	20-25	35-40	50-65
13"	20-25	35-40	50-65
14"	20-25	50-60	90-120
15"	20-25	50-60	90-120
16"	20-25	50-60	90-120

MIXER STORAGE

For storage of the mixer for over 30 days, the following is recommended:

- Drain the fuel tank completely, or add STA-BIL to the fuel.
- Run the engine until the gasoline in the carburetor is completely consumed.
- Completely drain the oil from the crankcase and refill with fresh oil.
- Clean the entire mixer and engine compartment.
- Place the mixing drum in the down position (mouth facing downward).
- Clean all external parts of the mixer with a cloth.
- Cover the mixer and place it a clean dry area, that is protected from harsh elements.

TROUBLESHOOTING (MIXER)

Troubleshooting (Mixer)		
Symptom	Possible Problem	Solution
Drum rotates rough.	Defective ring gear?	Check that the ring gear and bearings are not worn . Replace as necessary.
	Defective pinion gear?	Check that the pinion gear and bearings are not worn . Replace as necessary.
	Worn V-belt?	Replace V-belt.
	Loose pulley?	Tighten or replace pulley.
Drum does not rotate at all.	Incorrect or no voltage being supplied to electric motor?	Check that the electric motor has the correct supply voltage.
	Power to electric motor?	Inspect power source and extension cord. Push reset button on electric motor. Make sure correct voltage is being supplied to motor.
	Fuel?	Check level of fuel in fuel tank. Add fuel if necessary. Make sure fuel is being supplied to the engine. Check to ensure that the fuel filter is not clogged.
	Broken V-belt?	Replace V-belt.
	Defective ring or pinion gears?	Check that the gears and bearings are not broken. Replace as necessary.
	Defective electric motor?	Replace electric motor.

Troubleshooting (Electric Motor)		
Symptom	Possible Cause	Solution
Electric motor will not start.	Is there power?	Check power source. Check reset button.
	Is power cable plugged in?	Plug in power cable.
	Is ON/OFF switch placed in ON position?	Place ON/OFF switch in ON position.
	Defective electric motor ON/OFF switch?	Replace switch.
	Defective motor windings?	Repair windings or replace windings.
	Defective extension cord?	Replace extension cord.
Electric motor continuously stops.	Reset button OK?	Check power source.
Electric motor RPM's too low.	Low voltage?	Check input voltage.
Electric motor RPM's too high.	High voltage?	Check input voltage.

TROUBLESHOOTING (ENGINE)

Troubleshooting (Engine)		
Symptom	Possible Problem	Solution
Difficult to start, fuel is available, but no spark at spark plug.	Spark plug bridging?	Check gap, insulation or replace spark plug.
	Carbon deposit on spark plug?	Clean or replace spark plug.
	Short circuit due to deficient spark plug insulation?	Check spark plug insulation, replace if worn.
	Improper spark plug gap?	Set to proper gap.
	Spark plug is red?	Check transistor ignition unit.
	Spark plug is bluish white?	If insufficient compression, repair or replace engine. If injected air leaking, correct leak. If carburetor jets clogged, clean carburetor.
	No spark present at tip of spark plug?	Check transistor ignition unit is broken, and replace defective unit. Check if voltage cord is cracked or broken and replace. Check if spark plug is fouled. Replace if fouled.
	No oil?	Add oil as required.
	Oil pressure alarm lamp blinks upon starting? (if applicable)	Check automatic shutdown circuit, "oil sensor". (if applicable)
Difficult to start, fuel is available, and spark is present at the spark plug.	ON/OFF switch is shorted?	Check switch wiring, replace switch.
	Ignition coil defective?	Replace ignition coil.
	Improper spark gap, points dirty?	Set correct spark gap and clean points.
	Condenser insulation worn or short circuiting?	Replace condenser.
	Spark plug wire broken or short circuiting?	Replace defective spark plug wiring.
Difficult to start, fuel is available, spark is present and compression is normal.	Wrong fuel type?	Flush fuel system, replace with correct type of fuel.
	Water or dust in fuel system?	Flush fuel system.
	Air cleaner dirty?	Clean or replace air cleaner.
	Choke open?	Close choke.
Difficult to start, fuel is available, spark is present and compression is low.	Suction/exhaust valve stuck or protruded?	Reseat valves.
	Piston ring and/or cylinder worn?	Replace piston rings and/or piston.
	Cylinder head and/or spark plug not tightened properly?	Torque cylinder head bolts and spark plug.
	Head gasket and/or spark plug gasket damaged?	Replace head and spark plug gaskets.
No fuel present at carburetor.	No fuel in fuel tank?	Fill with correct type of fuel.
	Fuel cock does not open properly?	Apply lubricant to loosen fuel cock lever, replace if necessary.
	Fuel filter/lines clogged?	Replace fuel filter.
	Fuel tank cap breather hole clogged?	Clean or replace fuel tank cap.
	Air in fuel line?	Bleed fuel line.
Will not start, no power with key "ON". (if applicable)	ON/OFF device not in ON position?	Place ON/OFF device in ON position.

TROUBLESHOOTING (ENGINE)

Troubleshooting (Engine) - continued		
Symptom	Possible Problem	Solution
Weak in power, compression is proper and does not misfire.	Air cleaner dirty?	Clean or replace air cleaner.
	Improper level in carburetor?	Check float adjustment, rebuild carburetor.
	Defective spark plug?	Clean or replace spark plug.
	Improper spark plug?	Set to proper gap.
Weak in power, compression is proper but misfires.	Water in fuel system?	Flush fuel system and replace with correct type of fuel.
	Dirty spark plug?	Clean or replace spark plug.
	Ignition coil defective?	Replace ignition coil.
Engine overheats.	Spark plug heat value incorrect?	Replace with correct type of spark plug.
	Wrong type of fuel?	Replace with correct type of fuel.
	Cooling fins dirty?	Clean cooling fins.
	Intake air restricted?	Clear intake of dirt and debris. Replace air cleaner elements as necessary.
	Oil level too low or too high?	Adjust oil to proper level.
Rotational speed fluctuates.	Governor adjusted incorrectly?	Adjust governor.
	Governor spring defective?	Replace governor spring.
	Fuel flow restricted?	Check entire fuel system for leaks or clogs.
Recoil starter malfunctions. (if applicable)	Recoil mechanism clogged with dust and dirt?	Clean recoil assembly with soap and water.
	Spiral spring loose?	Replace spiral spring.
Burns too much fuel.	Over-accumulation of exhaust products?	Check and clean valves. Check muffler and replace if necessary.
	Wrong spark plug?	Replace spark plug with manufacturer's suggested type.
Exhaust color is continuously "white".	Lubricating oil is wrong viscosity?	Replace lubricating oil with correct viscosity.
	Worn rings?	Replace rings.
Exhaust color is continuously "black".	Air cleaner clogged?	Clean or replace air cleaner.
	Choke valve set to incorrect position?	Adjust choke valve to correct position.
	Carburetor defective, seal on carburetor broken?	Replace carburetor or seal.
	Poor carburetor adjustment, engine runs too rich?	Adjust carburetor.

OPERATION MANUAL

HERE'S HOW TO GET HELP

PLEASE HAVE THE MODEL AND SERIAL
NUMBER ON-HAND WHEN CALLING

UNITED STATES

Multiquip Inc.

(310) 537- 3700
6141 Katella Avenue Suite 200
Cypress, CA 90630
E-MAIL: mq@multiquip.com
WEBSITE: www.multiquip.com

CANADA

Multiquip

(450) 625-2244
4110 Industriel Boul.
Laval, Quebec, Canada H7L 6V3
E-MAIL: infocanada@multiquip.com

UNITED KINGDOM

Multiquip (UK) Limited Head Office

0161 339 2223
Unit 2, Northpoint Industrial Estate,
Globe Lane,
Dukinfield, Cheshire SK16 4UJ
E-MAIL: sales@multiquip.co.uk

© COPYRIGHT 2026, MULTIQUIP INC.

Multiquip Inc. and the MQ logo are registered trademarks of Multiquip Inc. and may not be used, reproduced, or altered without written permission. All other trademarks are the property of their respective owners and used with permission.

This manual MUST accompany the equipment at all times. This manual is considered a permanent part of the equipment and should remain with the unit if resold.

DISCLAIMER: Product features, descriptions, and specifications are based on published information at the time of publication and are subject to change at any time without notice. Multiquip Inc. and its affiliates reserve the right to change specifications, features, design, and descriptions of products at any time without notice.

