

MODULAR LIGHT TOWER — SCHEMATIC DIAGRAM

LIGHT TOWER SCHEMATIC DIAGRAM

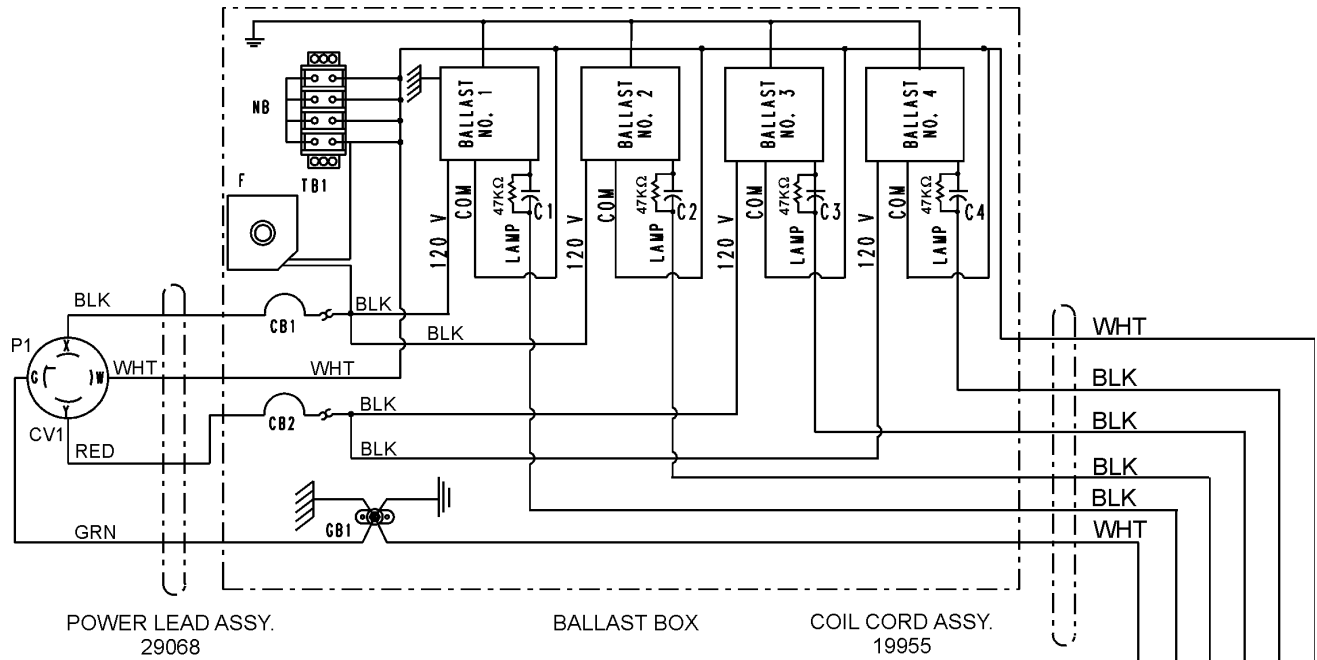

NOTE

Capacitors C1 thru C4 are 480 VAC, 24 μ f. In addition a 47K Ω (1/2 watt) resistor is installed across the capacitor terminals.

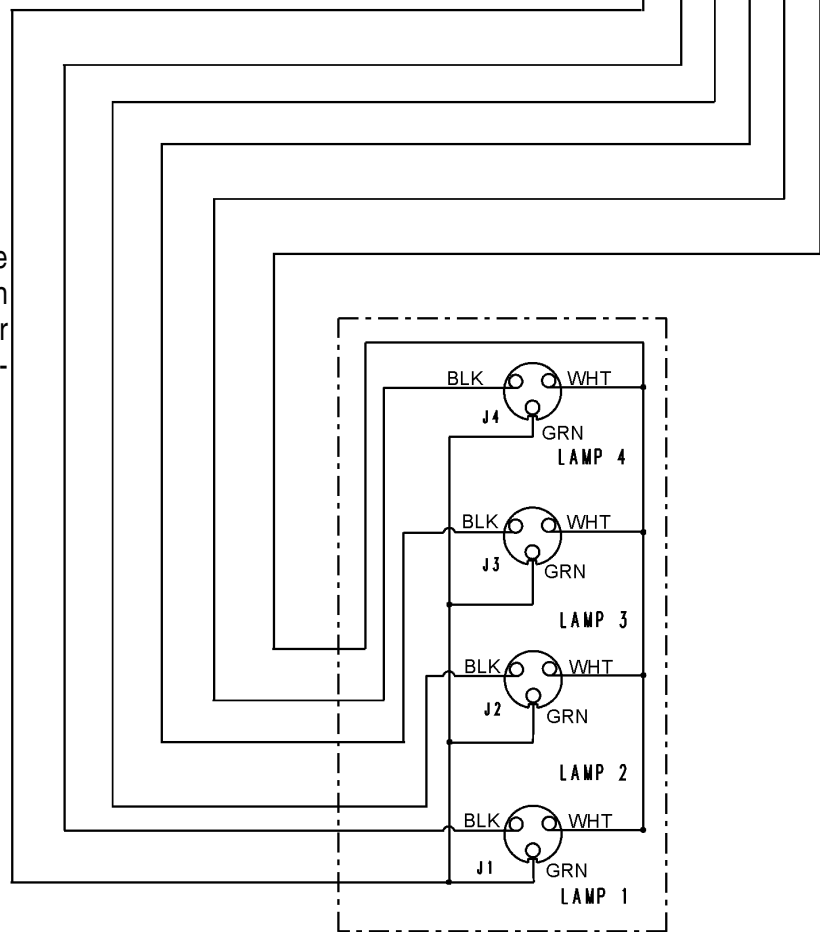

T-BAR ASSEMBLY - TWR, 19940

MODULAR LIGHT TOWER — BALLAST COMPARTMENT WIRING DIAGRAM.

BALLAST COMPARTMENT WIRING DIAGRAM

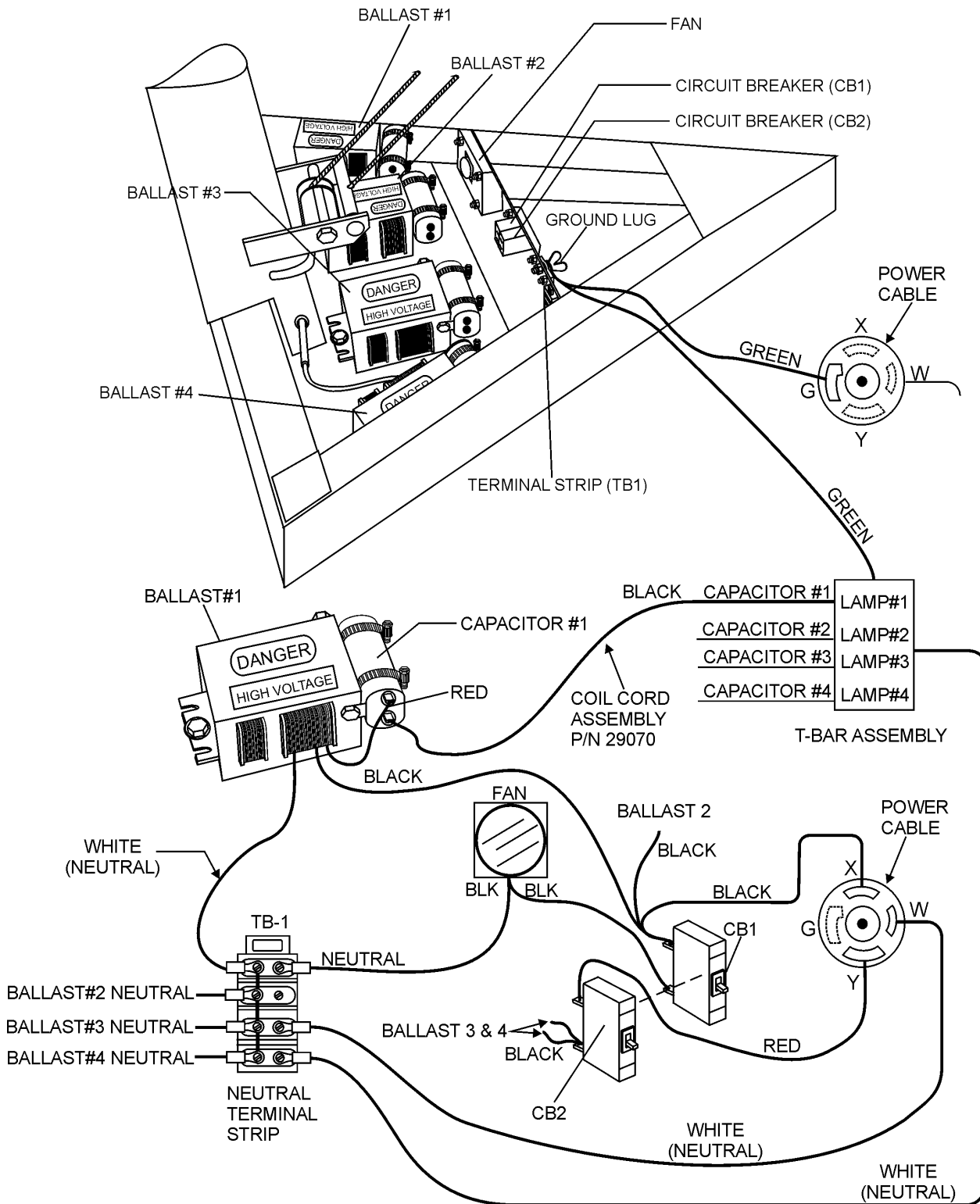

MODULAR LIGHT TOWER— ELECTRIC SWITCH WIRING DIAGRAM

ELECTRIC FUEL SWITCH WIRING DIAGRAM.

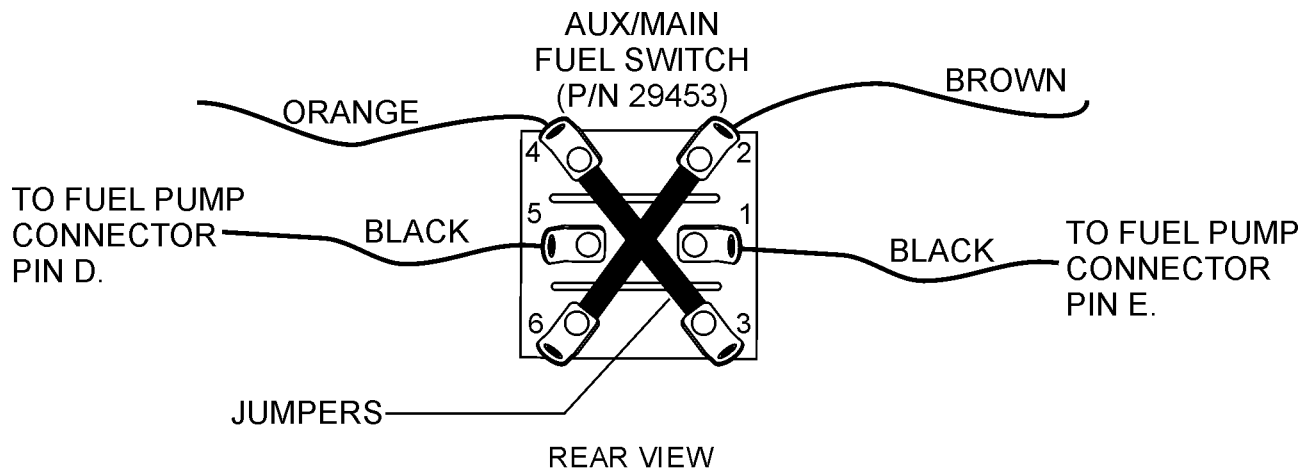
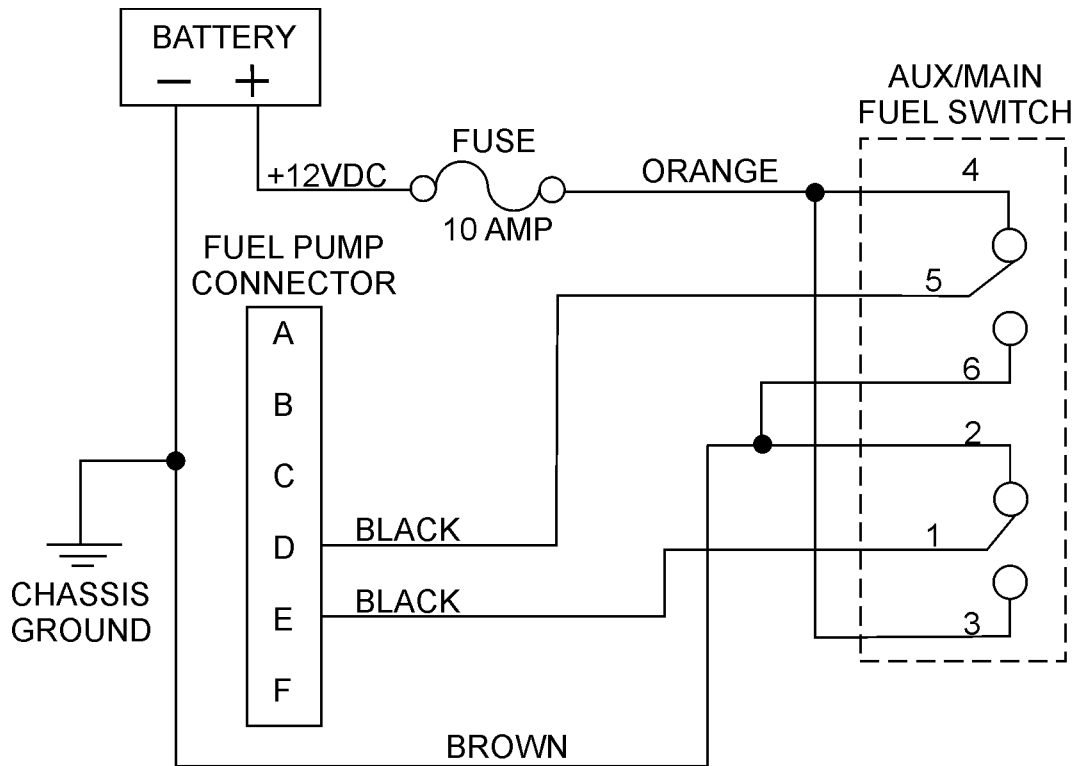

NOTE:
SWITCH POSITION SHOWN
IS FOR THE AUXILIARY
FUEL TANK (UP). DOWN
POSITION OF SWITCH
IS FOR MAIN TANK.