

OPERATION AND PARTS MANUAL



MP1 SERIES MODELS

MP1455H (5.5 HP GASOLINE)

MP1415E (1.5 HP ELECTRIC)

MP1420E (2.0 HP ELECTRIC)

MASONRY SAWS

Revision #3 (03/29/10)

To find the latest revision of this
publication, visit our website at:
www.multiquip.com



THIS MANUAL MUST ACCOMPANY THE EQUIPMENT AT ALL TIMES.

P/N 25939



CALIFORNIA — Proposition 65 Warning

Engine exhaust and some of its constituents, and some dust created by power sanding, sawing, grinding, drilling and other construction activities contains chemicals known to the State of California to cause cancer, birth defects and other reproductive harm. Some examples of these chemicals are:

- Lead from lead-based paints.
- Crystalline silica from bricks.
- Cement and other masonry products.
- Arsenic and chromium from chemically treated lumber.

Your risk from these exposures varies, depending on how often you do this type of work. To reduce your exposure to these chemicals: **ALWAYS** work in a well ventilated area, and work with approved safety equipment, such as dust masks that are specially designed to filter out microscopic particles.

SILICOSIS/RESPIRATORY WARNINGS

! WARNING



SILICOSIS WARNING

Grinding/cutting/drilling of masonry, concrete, metal and other materials with silica in their composition may give off dust or mists containing crystalline silica. Silica is a basic component of sand, quartz, brick clay, granite and numerous other minerals and rocks. Repeated and/or substantial inhalation of airborne crystalline silica can cause serious or fatal respiratory diseases, including silicosis. In addition, California and some other authorities have listed respirable crystalline silica as a substance known to cause cancer. When cutting such materials, always follow the respiratory precautions mentioned above.

! WARNING



RESPIRATORY HAZARDS

Grinding/cutting/drilling of masonry, concrete, metal and other materials can generate dust, mists and fumes containing chemicals known to cause serious or fatal injury or illness, such as respiratory disease, cancer, birth defects or other reproductive harm. If you are unfamiliar with the risks associated with the particular process and/or material being cut or the composition of the tool being used, review the material safety data sheet and/or consult your employer, the material manufacturer/supplier, governmental agencies such as OSHA and NIOSH and other sources on hazardous materials. California and some other authorities, for instance, have published lists of substances known to cause cancer, reproductive toxicity, or other harmful effects.

Control dust, mist and fumes at the source where possible. In this regard use good work practices and follow the recommendations of the manufacturers or suppliers, OSHA/NIOSH, and occupational and trade associations. Water should be used for dust suppression when wet cutting is feasible. When the hazards from inhalation of dust, mists and fumes cannot be eliminated, the operator and any bystanders should always wear a respirator approved by NIOSH/MSHA for the materials being used.

TABLE OF CONTENTS

MP1 MASONRY SAW

Proposition 65 Warning	2
Silicosis/Respiratory Warnings	3
Table Of Contents	4
Parts Ordering Procedures	5
Safety Message Alert Symbols	6-7
Rules For Safe Operation	8-10
Operation and Safety Decals	11
Specifications	12
Dimensions	13
General Information	14
Controls and Components	16-17
Electric Motor Components	18
Engine Components	19
Pre-Setup (Electric)	20-23
Pre-Setup (Gasoline)	24-25
Operation (Electric)	26-27
Operation (Electric)	28-29
Maintenance	30-33
Electric Motor Wiring Diagram	34
Troubleshooting (Blade)	36
Troubleshooting (Electric Motor)	37
Troubleshooting (Gasoline Engine)	38-39
Explanation of Code In Remarks Column	40
Suggested Spare Parts	41

HONDA GX160K1QXC9 GASOLINE ENGINE

MP1 COMPONENT DRAWINGS

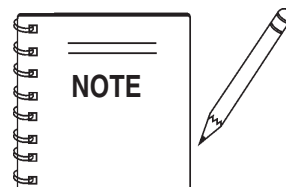

PARTS ORDERING PROCEDURES

Ordering parts has never been easier! Choose from three easy options:

Effective:
January 1st, 2006

www.multiquip.com



Order via Internet (Dealers Only):

Order parts on-line using Multiquip's SmartEquip website!

- View Parts Diagrams
- Order Parts
- Print Specification Information



If you have an MQ Account, to obtain a Username and Password, E-mail us at: parts@multiquip.com.

To obtain an MQ Account, contact your District Sales Manager for more information.

Goto www.multiquip.com and click on

Order Parts to log in and save!

Use the **internet** and qualify for a **5% Discount** on *Standard orders* for all orders which include complete part numbers.*

Note: Discounts Are Subject To Change



Order via Fax (Dealers Only):

All customers are welcome to order parts via Fax.

Domestic (US) Customers dial:

1-800-6-PARTS-7 (800-672-7877)

Fax your order in and qualify for a **2% Discount** on *Standard orders* for all orders which include complete part numbers.*

Note: Discounts Are Subject To Change



Order via Phone: Domestic (US) Dealers Call:

1-800-427-1244

Non-Dealer Customers:

Contact your local Multiquip Dealer for parts or call 800-427-1244 for help in locating a dealer near you.



International Customers should contact their local Multiquip Representatives for Parts Ordering information.

When ordering parts, please supply:

- | | |
|---|--|
| <input type="checkbox"/> Dealer Account Number | <input type="checkbox"/> Specify Preferred Method of Shipment: |
| <input type="checkbox"/> Dealer Name and Address | <input checked="" type="checkbox"/> UPS/Fed Ex <input checked="" type="checkbox"/> DHL |
| <input type="checkbox"/> Shipping Address (if different than billing address) | <input type="checkbox"/> Priority One <input checked="" type="checkbox"/> Truck |
| <input type="checkbox"/> Return Fax Number | <input type="checkbox"/> Ground |
| <input type="checkbox"/> Applicable Model Number | <input type="checkbox"/> Next Day |
| <input type="checkbox"/> Quantity, Part Number and Description of Each Part | <input type="checkbox"/> Second/Third Day |

NOTICE

All orders are treated as *Standard Orders* and will ship the same day if received prior to 3PM PST.

WE ACCEPT ALL MAJOR CREDIT CARDS!



SAFETY MESSAGE ALERT SYMBOLS

FOR YOUR SAFETY AND THE SAFETY OF OTHERS!

Safety precautions should be followed at all times when operating this equipment. Failure to read and understand the Safety Messages and Operating Instructions could result in injury to yourself and others.

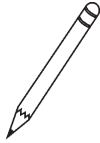
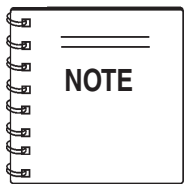

This Owner's Manual has been developed to provide complete instructions for the safe and efficient operation of the **MULTIQUIP MP1**

Before using this MASONRY SAW, ensure that the operating individual has read and understands all instructions in this manual.

SAFETY MESSAGE ALERT SYMBOLS

WARNING

CAUTION

DANGER



DANGER:

WILL KILLED
DO NOT



WARNING:

CAN KILLED
DO NOT



CAUTION:
DO NOT

CAN

Hazard Symbols

Message Alert Symbols

HAZARD SYMBOLS



Guards and Covers In Place



NEVER



Rotating Blade



Burn Hazards



DO NOT
NEVER



Rotating Parts



NEVER

clothing

hands hair



Accidental Starting



OFF ALWAYS

OFF

ON/OFF

SAFETY MESSAGE ALERT SYMBOLS

Over Speed Conditions



Respiratory Hazard



Sight and Hearing hazard



Equipment Damage Messages

HAZARD SYMBOLS - Gasoline Powered Models

Lethal Exhaust Gases



Explosive Fuel

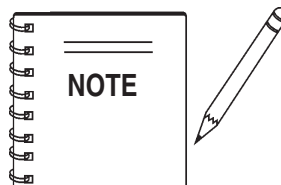
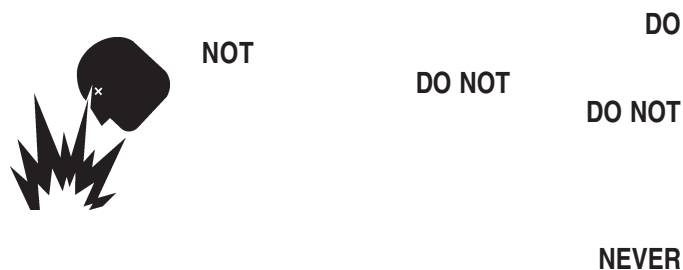

This *saw*, other property, or the surrounding environment could be damaged if you do not follow instructions.

RULES FOR SAFE OPERATION

CAUTION:



Failure to follow instructions in this manual may lead to serious injury or even death! This equipment is to be operated by trained and qualified personnel only! This equipment is for industrial use only.

The following safety guidelines should always be used when operating the MP1 SAW. Unless otherwise noted, these guidelines refer to saws with gasoline powered engines.

SAFETY

- **DO NOT** operate or service this equipment before reading this entire manual.



- This equipment should not be operated by persons under 18 years of age.

- **NEVER** operate the saw without proper protective clothing, shatterproof glasses, steel-toed boots and other protective devices required by the job.



- **NEVER** operate this equipment when not feeling well due to fatigue, illness or taking medicine.



- **NEVER** operate the saw under the influence of drugs or alcohol.

- **NEVER** use accessories or attachments, which are not recommended by Multiquip for this equipment. Damage to the equipment and/or injury to user may result.



- Manufacturer does not assume responsibility for any accident due to equipment modifications. Unauthorized equipment modification will void all warranties.

- Whenever necessary, replace nameplate, operation and safety decals when they become difficult read.

- **ALWAYS** check the saw for loosened threads or bolts before starting.

- **NEVER** operate the saw in an explosive atmosphere where fumes are present or near combustible materials. An explosion or fire could result causing severe **bodily harm or even death**.

- **NEVER** use fuel as a cleaning agent.

SAFETY - GASOLINE POWERED ENGINES

- **NEVER** touch the hot exhaust manifold, muffler or cylinder. Allow these parts to cool before servicing the saw.



- **High Temperatures** – Allow the engine to cool before adding fuel or performing service and maintenance functions. Contact with **hot!** components can cause serious burns.

- The engine of this saw (**gasoline model only**) requires an adequate free flow of cooling air. **NEVER** operate the saw in any enclosed or narrow area where free flow of the air is restricted. If the air flow is restricted it will cause serious damage to the saw's engine and may cause injury to people. Remember the saw's engine gives off **DEADLY** carbon monoxide gas.

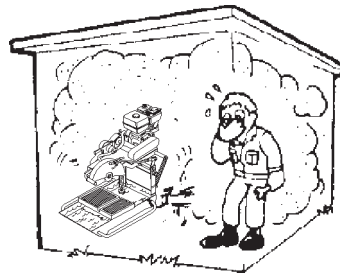

- **ALWAYS** stop the engine before servicing, adding fuel and oil.

- **ALWAYS** refuel in a well-ventilated area, away from sparks and open flames.

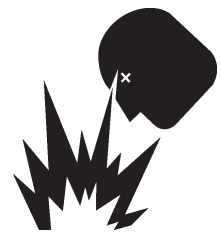

- **ALWAYS** use extreme caution when working with **flammable** liquids. When refueling, **stop the engine** and allow it to cool.

- **NEVER** smoke around or near the machine. Fire or explosion could result from **fuel vapors**, or if fuel is spilled on a **hot!** engine.



- Topping-off to filler port is dangerous, as it tends to spill fuel.
- **ALWAYS** service air cleaner frequently to prevent carburetor malfunction.
- **NEVER** run the engine without the air filter. Severe engine damage could occur. (Gasoline powered engines)

RULES FOR SAFE OPERATION

SAFETY - ELECTRIC POWERED MODELS

- **ALWAYS** connect the motor to a power source in compliance with all local electrical codes. This must be performed by a qualified electrician.
- **ALWAYS** use only outdoor approved **GROUND**ED extension cords.
- **MAKE CERTAIN** the power cord/extension cord is free from damage and that the grounding circuit is operational.
- **MAKE CERTAIN** the extension cord used is intended to be used in the environment you will be using it in. If an extension is used, **NEVER** submerge the connection in water. To reduce the risk of electrical shock, always make water-tight connections.
- **MAKE CERTAIN** the "ON/OFF" switch is in the "OFF" position before plugging in the power cord/extension cord to avoid accidental starting.
- **ALWAYS** stop the motor before servicing. **MAKE CERTAIN** the motor is stopped and turned "OFF" at the switch, and the power cord is disconnected from the power source.
- Use only the gauge wire and length of cord recommended for the motor size.
- When cutting, **ALWAYS** be aware of the location of the cord.

GENERAL SAFETY

- **ALWAYS** read, understand, and follow procedures in Operator's Manual before attempting to operate equipment.
- **ALWAYS** be sure the operator is familiar with proper safety precautions and operating techniques before using the saw.
- **NEVER** leave the machine *unattended* while running.
- Block the unit when leaving or when using on a slope.
- **ALWAYS** check to make sure that the operating area is clear before starting the engine.
- Maintain this equipment in a safe operating condition at all times.
- **AVOID** wearing jewelry or loose fitting clothing that may snag on the controls or moving parts, this can cause a serious injury.
- **ALWAYS** keep clear of *rotating* or *moving parts* while operating or the saw.
- **ALWAYS** store equipment properly when it is not being used. Equipment should be stored in a clean, dry location out of the reach of children.
- **NEVER** use accessories or attachments which are not recommended by the manufacturer for this equipment. Damage to the equipment and/or injury to user may result.

WARNING





- **ALWAYS** check to make sure that the operating area is clear before starting the engine.

BLADE SAFETY

- Use appropriate blades manufactured for use on masonry saws.

WARNING

- Always inspect blades before each use. The blade should exhibit no cracks, dings, or flaws in the steel centered core and/or rim. Center (arbor) hole must be undamaged and true. 
- Examine blade flanges for damage, excessive wear and cleanliness before mounting blade. Blade should fit snugly on the shaft and against the inside/outside blade flanges.
- Ensure the blade is marked with an operating speed greater than the blade shaft speed of the saw.
- Only cut the material that is specified by the blade. Read the specifications of the blade to ensure the proper tool has been matched to the material being cut.
- Always keep blade guards in place. Exposure of the blade must not exceed 180 degrees.
- **NEVER** touch or try to stop a moving blade with your hands. **ALWAYS** keep hands clear of the blade. 
- Ensure that the blade does not come into contact with the ground or surface during transportation. **DO NOT** drop the blade on ground or surface.
- The engine governor is designed to permit maximum engine speed in a no-load condition. Speeds that exceed this limit may cause the blade to exceed the maximum safe allowable speed.
- Ensure that the blade is mounted for proper operating direction.
- Keep all inexperienced and unauthorized people away from the equipment at all times.
- **ALWAYS** use or operate the saw on a level surface to prevent the saw from tipping.

RULES FOR SAFE OPERATION

SAW MAINTENANCE (CLEANING)

- **ALWAYS** clean the saw before maintenance or repair.
- **DO NOT** use aggressive cleaners (i.e. containing solvents). **DO NOT** use high pressure water jets, aggressive detergents or solutions and liquids with a temperature exceeding 86 F. Use a fluff-free cloth only.
- Use a cloth which may be lightly moistened only for removing dust and dirt. Hard packed dirt can be removed with a **soft** brush.
- **NEVER** let water, cleaning liquid or vapor penetrate into the electric motor, connectors, plugs, and switches. When cleaning cover all apertures or openings on all electrical components.
- **ALWAYS** use a soft, low-pressure water jet and a brush to rinse dirt and incrustations away. Be particularly careful not to spray water on sensitive parts of the saw (e.g. electric motor, ON/OFF switch). Clean the motor and ON/OFF switch by wiping with a **moist** cloth.
- **DO NOT** rinse the bearings of the drive elements (gasoline model only).

SAW TRANSPORTATION SAFETY

- Use an appropriate lifting equipment to ensure the safe movement of the saw.
- **DO NOT** use the handles as lifting points.
- Safeguard against extreme saw attitudes relative to level. An engine tipped to extreme angles may cause oil to gravitate into the cylinder head making the engine start difficult. (Gasoline powered engines)
- **NEVER** transport the saw with the blade mounted.

EMERGENCIES

- **ALWAYS** know the location of the nearest **fire extinguisher**.



- **ALWAYS** know the location of the nearest and **first aid kit**.



- **always** know the location of the nearest phone or **keep a phone on the job site**. Also know the phone numbers of the nearest **ambulance, doctor** and **fire department**. This information will be invaluable in the case of an emergency.



SPECIFICATIONS (SAW/ENGINE)

TABLE 1. MP1 SAW SPECIFICATIONS	
Dimensions	43.75" x 33" x 27" (111.125 cm x 83.82 cm x 68.58 cm)
Approximate Weight	165 lbs. (75 Kg.)
Electric Motor Speed	3450 RPM (See Table 2)
Blade Speed	2588 RPM
Water Pump	115V/60Hz, Thermally protected
Engine (Gasoline)	5.5 HP 4 cycle, Single Cylinder, Air Cooled, Honda (See Table 2)
Blade Speed	2800 RPM
Water Pump	Optional Kit 25807-502
GENERAL	
Blade Capacity	14 in. blade maximum
Cutting Depth	5 in. with 14 in. blade

TABLE 2. MP1 ELECTRIC MOTOR/GAS ENGINE SPECIFICATIONS			
Saw Model	MP1455HP	MP1415E	MP1420E
Engine/Motor	Honda GX160K1QXC9	1.5 H.P. Heavy Duty Electric 115/230V Single Phase 60 Hz Dual Voltage Amps F.L. 17.2/8.6	2.0 H.P. Heavy Duty Electric 115/230V Single Phase 60 Hz Dual Voltage Amps F.L. 16.8/8.4
Type	4-Stroke OHV Single Cylinder		
Bore & Stroke	2.7 x 1.8 in. (68 x 45 mm)		
Displacement	9.9 cu. in. (163 cc)		
Max Output	5.4 bhp (4.0 KW) @ 3600 rpm		
Fuel Tank Cap.	0.95 U.S. Gal. (3.6 liters)		
Fuel	Unleaded Gasoline		
Lube Oil Cap.	0.63 U.S. Qt. (0.60 liters)		
Speed Control Method	Centrifugal Fly-Weight type		
Starting Method	Recoil Start		
Dimension	12.0 x 14.3 x 13.2 In. (304 x 362 x 335 mm)		
Dry Net Weight	33.1 Lbs. (15.0 Kg)		

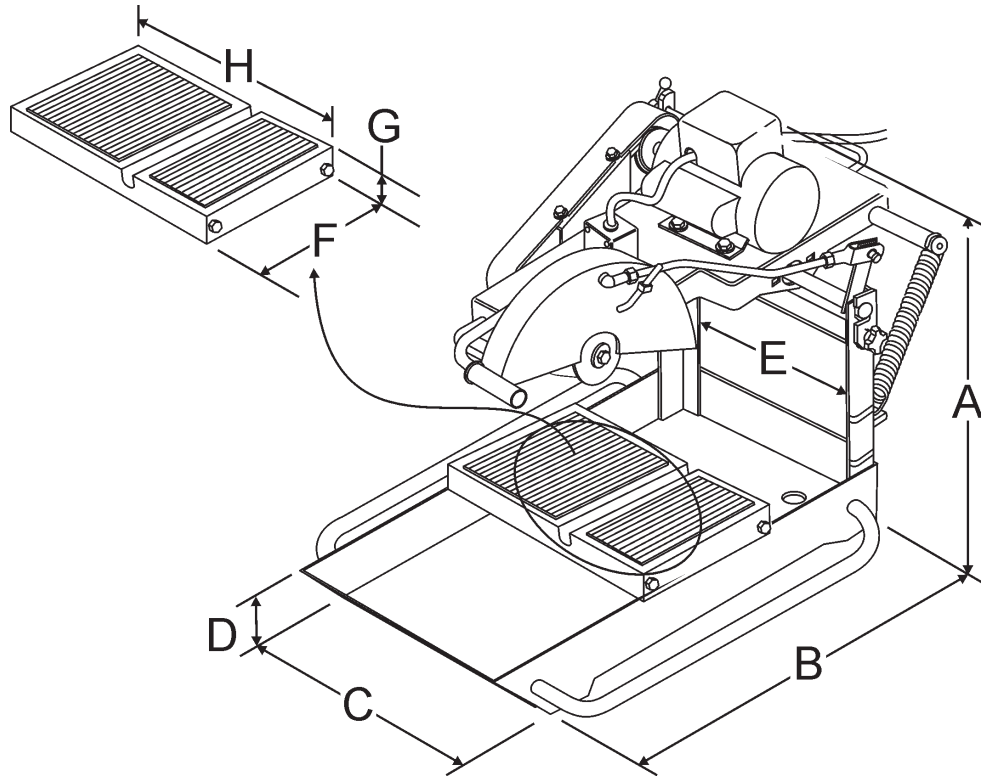

Figure 1. Dimensions

TABLE 3. DIMENSIONS	
REF.	DIMENSIONS
A (electric motor)	29.0 in. (74 cm)
A (gasoline engine)	29.0 in. (74 cm)
B	42.0 in. (106 cm)
C	27.0 in. (58.6 cm)
D	5.5 in. (13.97 cm)
E	14.5 in. (36.8 cm)
F	11.5 in. (29.2 cm)
G	2.5 in. (6.35 meters)
H	19.0 in. (48.2 meters)

GENERAL INFORMATION

MP1 MASONRY SAW

The MP1 masonry saw is designed for vigorous wet-cutting masonry applications. The heavy-duty aluminum conveyor cart and ball bearing roller wheels ensure material stability and smooth travel. In addition a reinforced jig-welded steel frame provides rigidity for cutting accuracy and long service life.

This saw is available with either an **electric motor** or a **gasoline engine**. The heavy duty electric motors are available in either 1.5 HP or 2.0 HP with overload protection. Each motor can operate at either 115 VAC or 230 VAC. The electric motor input voltage is selectable by means of a toggle switch. Always make sure that the input voltage being supplied to the motor matches the position of the voltage selector toggle switch located on top of the motor.

If desired, the MP1 saw can be configured with a 5.5 HP Honda GX160 gasoline engine.

All MP1 models include a high flow water pump, cutting jig, water hoses and associated plumbing to enable the operator to begin wet cutting.

DRY CUTTING APPLICATIONS

The MP1 masonry saw is shipped from the factory for wet-cutting saw applications, however it can be used for **dry-cutting saw** applications (see dry-cutting saw applications in this manual). The most important thing to remember is to **disconnect the water pump**. The water pump is cooled by the flow of water, and failure to disconnect the pump (when running dry) will cause pump failure. **NEVER!** have the water pump engaged when dry cutting applications are involved.

BLADE APPLICATIONS

This saw has been designed to incorporate the use of Diamond Blades™ as the cutting tool. The optimum performance of this saw is best evidenced by using 14-inch (356 mm) Diamond Blades™ that match the material being cut. Ask your dealer, or call **MULTIQUIP** about your specific cutting application.

ACCESSORIES/REPLACEMENT PARTS

If desired the MP1 masonry saw can be equipped with a scissors type support stand P/N TRAK14SS, this stand is ideal when the saw needs to be transported and placed on a secure reliable platform.

OVERVIEW OF FEATURES

- 1.5 or 2.0 HP, 115/230 VAC, 60 Hz heavy duty electric motors with overload protection.
- 5.5 HP Honda GX160 gasoline engine.
- 14-inch blade capacity provides 5-inch depth of cut.
- Rugged aluminum conveyor cart for optimum stability.
- Open back design permits capability of cutting large materials.
- Ergonomically designed cutting head provides operator relief in high tempo operations.
- Mounted carrying handles for easy transportation.
- Rubber-matted cutting table helps hold the material being cut in place while resisting vibrations for smoother cuts with less chipping.
- Cutting table marked in inches and centimeters (ruler) for precision cuts.
- Stay-level blade guard for operator safety.
- Rigid steel frame minimizes vibrations and assures accurate cutting.
- Mechanical Water Pump Kit (Gasoline Model Only)
- Electric Submersible Water Pump Kit (Electric Models Only).

CONTROLS AND COMPONENTS

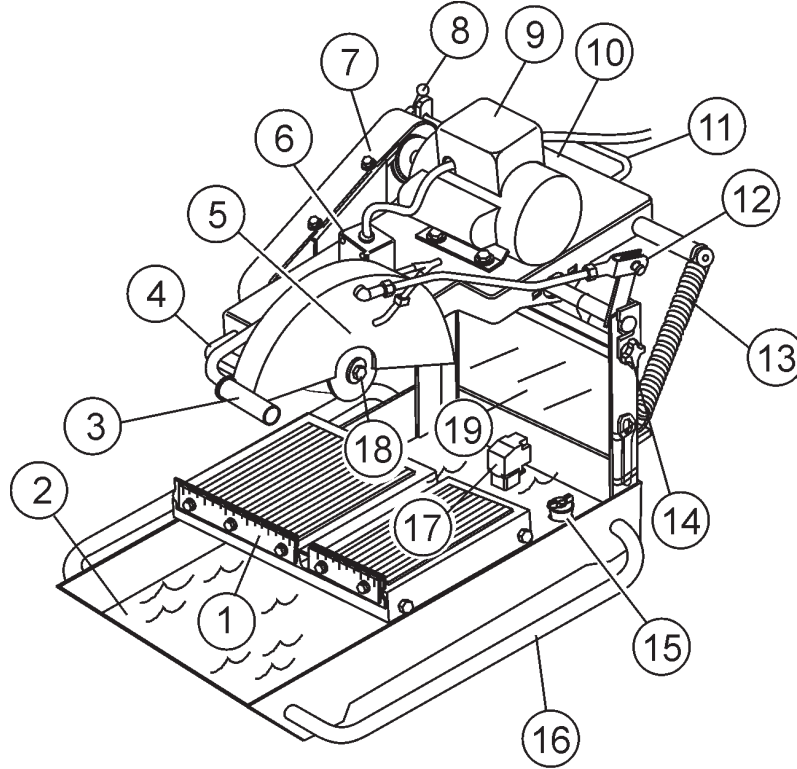
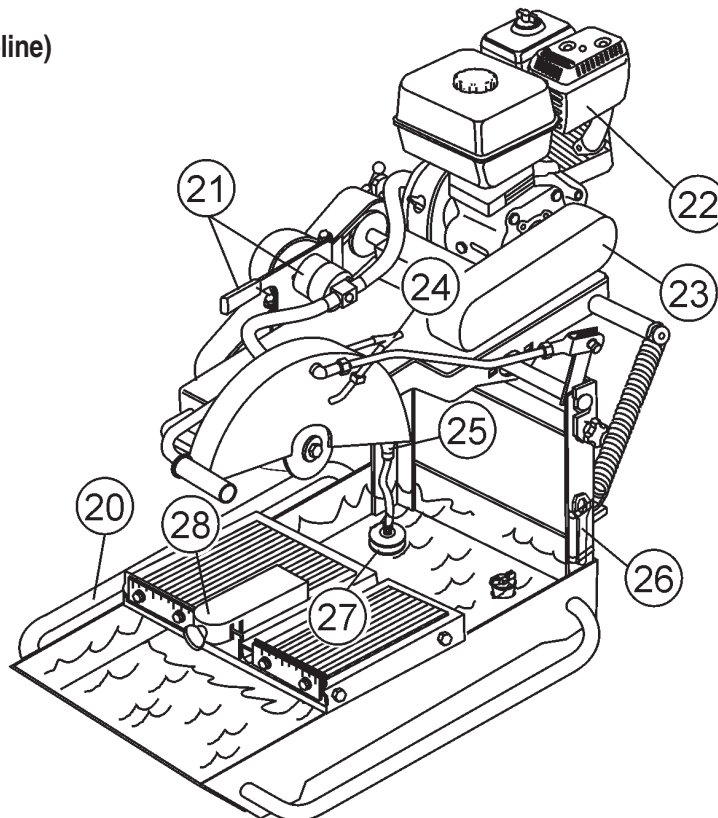

Figure 2. MP1 Saw (Electric/Gasoline)



CONTROLS AND COMPONENTS

Figure 2 shows the location of the basic controls or components for the MP1 saw. Listed below is a brief explanation of each control or component.

1. **Ruler Backstop** – When cutting, place material against backstop. Use measurement rail (ruler) to determine where material is to be cut.
2. **Water Tray** – When wet cutting is required, fill with clean fresh water. Make sure submersible is totally immersed in water.
3. **Cutting Head Handle** – Grab hold of this handle to move the cutting blade head either **up** or **down**. To move the cutting head, release the mounting plate release/lock lever.
4. **Carrying Handle (Head)** – Grip this handle (front) to lift the mounting plate.
5. **Blade Guard** – Protects the user from the cutting blade. **NEVER** operate the saw with the blade guard removed.
6. **Power ON/OFF Box** – This box is used on **electric models saws only**. To turn on the saw place in the **ON** position. Place in the **OFF** position to shut-down the saw.
7. **V-belt Cover** – Remove this cover to access the drive V-belt. **NEVER** operate the saw with the V-belt cover removed.
8. **Mounting Plate Release/Lock Lever** – Push this lever **backwards to release** the mounting plate. This will allow the cutting head to move either up or down. Push the lever **forward to lock** the mounting plate in place.
9. **Electric Motor/Conduit Box** – This unit uses 2 different types of electric motors and voltages (see Table 2). Always make sure the voltage selector switch has been set to the correct position for the voltage being supplied to the motor. Plug the water pump (electric models only) power cord into the AC receptacle located on the conduit box.
10. **Mounting Plate** – Supports the electric motor/gasoline engine. Plate has slotted holes for horizontal (right-side) and vertical (left-side) adjustment of cutting head.
11. **Carrying Handle (Head)** – Grip this handle (rear) to lift the mounting plate.
12. **Tie Rod** – The tie rod length has been set at the factory for best blade guard position for the majority of the cutting that will be done.
13. **Spring Tensioner** – Allows for an easy up and down movement of the mounting plate.
14. **Mounting Plate Lock/Release Knobs** – Turn knob (2) clockwise to release the mounting plate. Turn counter-clockwise to tighten.
15. **Stopper** – Place stopper in tray when filling with water.
16. **Carrying Handle (Tray)** – Grip this handle (right-side) to transport the saw.
17. **Electric Water Pump** – For best results place the pump between the splash shield and the rear of the water tray. This is for electric models only. Plug water pump power cord into AC receptacle on electric motor conduit box. **NEVER** run pump dry. Pump must be immersed in water.
18. **Spindle Bolt/Outside Blade Flange** – When mounting of the cutting blade is required, remove the spindle bolt and outside blade flange. Align cutting blade with inside flange arbor and reassemble spindle and outside blade flange.
19. **Splash Guard** – Keeps water and debris from leaving the water tray.
20. **Carrying Handle (Tray)** – Grip this handle (left-side) to transport the saw.
21. **Mechanical Water Pump** – This pump is used on gasoline models only. Saw is shipped from the factory for wet cutting applications (pump handle down). Place pump handle upwards to disengage pump. **NEVER** run pump dry.
22. **Engine** – The gasoline model saws uses a 5.5 HP Honda GX160, 4-stroke, OHV, single cylinder, air cooled gasoline engine.
23. **V-belt Cover (Gasoline Only)** – Remove this cover to access the engine shaft-side V-belt. **NEVER** operate the saw with the V-belt cover removed.
24. **Water Lines** – Replace the clear vinyl tubing water lines when they become brittle, worn or clogged. Water kits are available through your dealer.
25. **Priming Bulb** – Squeeze this bulb to prime the mechanical water pump (gasoline models only).
26. **Blade Wrench** – Use this tool to mount and remove cutting blade.
27. **Strainer** – For best results place the strainer between the splash shield and the rear of the water tray. This is for gasoline models only. **NEVER** run pump dry. Strainer must be immersed in water.
28. **Miter Box** – For angled cuts, place the lip of the miter box on the measurement rail with the threaded thumb knob facing you and tighten.

MP1 — ELECTRIC MOTOR COMPONENTS

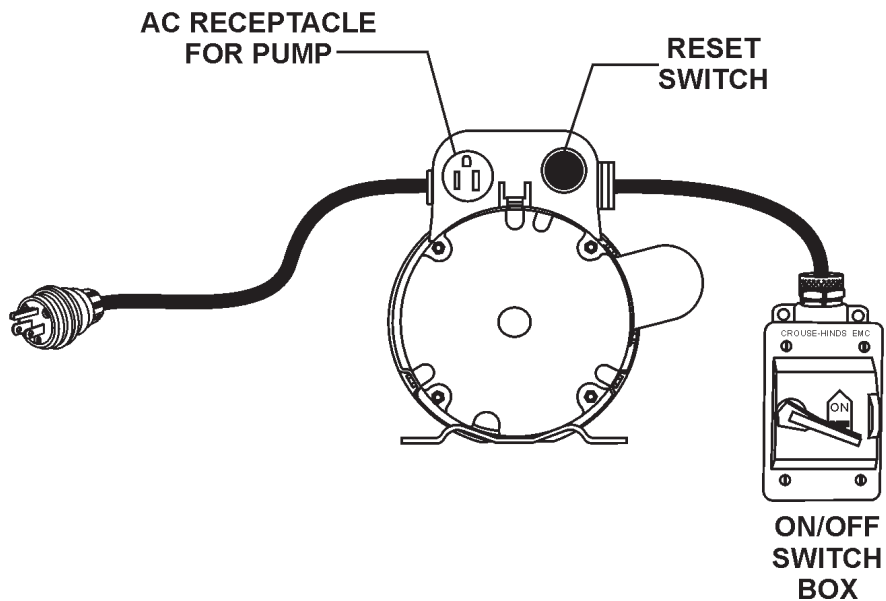
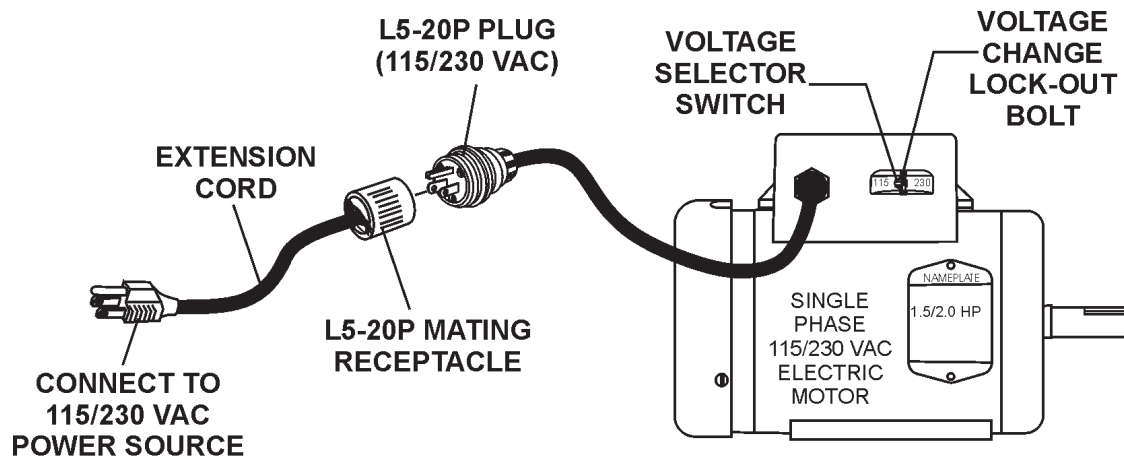

Figure 3. Electric Motor Components

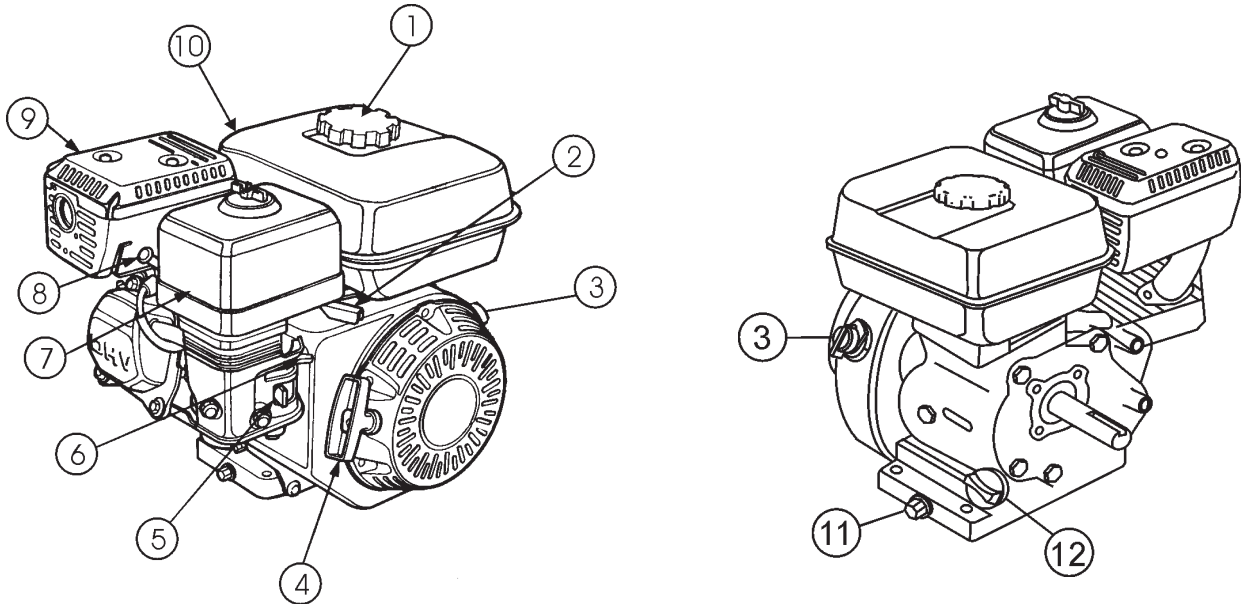
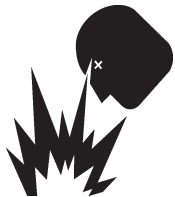

Figure 4. Engine Controls and Components

INITIAL SERVICING-GASOLINE ENGINE

The engine (Figure 4) must be checked for proper lubrication and filled with fuel prior to operation. Refer to the manufacturers engine manual for instructions & details of operation and servicing.

1. **Fuel Filler Cap** – Remove this cap to add unleaded gasoline to the fuel tank. Make sure cap is tightened securely. **DO NOT** over fill.



DANGER

Adding fuel to the tank should be done only when the engine is stopped and has had an opportunity to cool down. In the event of a fuel spill, **DO NOT** attempt to start the engine until the fuel residue has been completely wiped up, and the area surrounding the engine is dry.

2. **Throttle Lever** – Used to adjust engine RPM speed (lever advanced forward **SLOW**, lever back toward operator **FAST**).
3. **Engine ON/OFF Switch** – **ON** position permits engine starting, **OFF** position stops engine operations.
4. **Recoil Starter (pull rope)** – Manual-starting method. Pull the starter grip until resistance is felt, then pull briskly and smoothly.
5. **Fuel Valve Lever** – **OPEN** to let fuel flow, **CLOSE** to stop the flow of fuel.
6. **Choke Lever** – Used in the starting of a cold engine, or in cold weather conditions. The choke enriches the fuel mixture.

7. **Air Cleaner** – Prevents dirt and other debris from entering the fuel system. Remove wing-nut on top of air filter cannister to gain access to filter element.

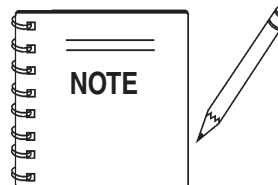

Operating the engine without an air filter, with a damaged air filter, or a filter in need of replacement will allow dirt to enter the engine, causing rapid engine wear.

8. **Spark Plug** – Provides spark to the ignition system. Set spark plug gap to 0.6 - 0.7 mm (0.028 - 0.031 inch) Clean spark plug once a month.
9. **Muffler** – Used to reduce noise and emissions



WARNING

Engine components can generate extreme heat. To prevent burns, **DO NOT** touch these areas while the engine is running or immediately after operating. **NEVER** operate the engine with the muffler removed.

10. **Fuel Tank** – Holds unleaded gasoline. For additional information refer to engine owner's manual.
11. **Oil Drain Bolt** – Drain used oil while the engine is warm.
12. **Oil Level Cap and Dipstick** – Check engine oil with engine stopped and in a level position.

PRE-SETUP (ELECTRIC)

PRE-SETUP



Whenever cleaning, adjusting or lubricating any part of the saw, **MAKE CERTAIN** to place the power **ON/OFF** switch in the **OFF** position and disconnect the plug from the power source.

Assembly (Electric Powered Saws Only)

1. Open the shipping container carefully, lift the saw by its carrying handles and place it on a suitable table or platform. Make sure the table or platform can support the weight of the saw. The saw platform should be rigid and stationary so that it will not move, sag, or sway due to the vibrations and movements of the saw.
2. If using the MP1 series **support stand kit** (P/N TRAK14SS), attach stand to the under-side of the water tray. Follow the instructions supplied with the support stand kit when attaching it to the water tray.
3. Attach the clear plastic water hose (Figure 5) coming from the blade guard to the water pump.
4. Fill the water tray with **clean fresh water**. The **water pump intake must always be fully covered by water**. Also, keep the pump intake free of sludge, debris and other materials that may accumulate in the tray.
5. Make certain that the water hose will not come in contact with the blade or interfere with any moving parts. The best location for the water pump/strainer is between the splash shield and the rear of the water tray. This will prevent some of the abrasive particles from flowing through the pump.

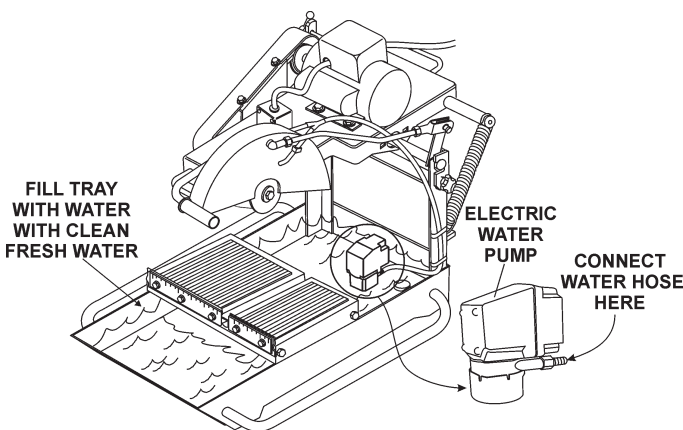

Figure 5. Water Tray/Water Pump

6. Insert the water pump **power plug** into the outlet receptacle on the electric motor conduit box as shown in Figure 6.

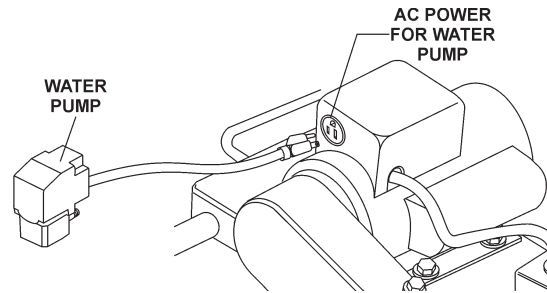

Figure 6. Water Pump Power Connection

CONVEYOR CART PLACEMENT

1. Place the conveyor cart across the water tray as shown in Figure 7. Align the wheels of the cart with the outer edge of the water tray. Push the cart back and forth, it should move freely in both directions.

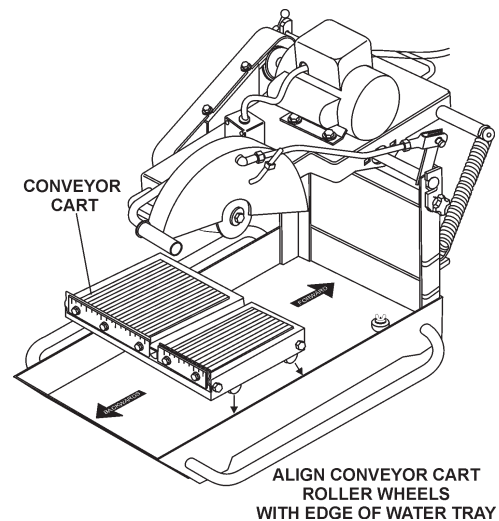

Figure 7. Conveyor Cart Placement

PRE-SETUP (ELECTRIC)

WARNING



Failure to thoroughly inspect the blade for operational safety could result in damage to the blades or the saw and may cause serious injury to the user or others in the operating area. Inspect the blade flanges and shaft for damage before installing the blade.

SAW BLADES

Diamond Blades™ are recommended for you saw. Ask your **MULTIQUIP dealer™** about your specific cutting application.

SAW BLADE DEFINITIONS (FIGURE 8)

1. **Stress Relief Holes (Gullets)** - Check the steel core for cracks that may have propagated from the slots and/or gullets. Cracks indicate extreme fatigue failure and if sawing continues, catastrophic failure will occur.

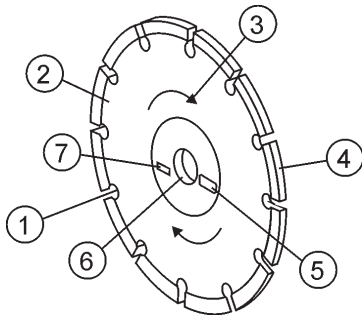

Figure 8. Diamond Blade

2. **Edge of the Steel Core** - Check the diameter edge for discoloration (blue oxidation) indicating an overheating condition caused by insufficient cooling water/air. Overheating of blades may lead to loss of core tension and/or increase the possibility for blade failure. Make sure the steel core's width is uniform about the rim of the blade, and not succumbing to an "under-cutting" condition brought about by highly abrasive material or improper under-cutting core protection.
3. **Directional Arrow** - Ensure that the blade is oriented properly on the blade shaft for sawing. Reference the directional arrow on the blade and place it so the direction of rotation "downcuts" with the turn of the shaft.

4. **Diamond Segment or Rim** - Ensure there are no cracks, dings, or missing portions of the diamond segment/rim. **DO NOT use a blade that is missing a segment or a portion of the rim.** Damaged and /or missing segments/rims may cause damage to your saw or injury to the user or others in the operating area.
5. **Specifications** - Ensure that the blade specifications, size, and diameter properly match up to sawing operations. Utilizing a blade not matched properly to the task may result in poor performance and/or blade damage.
6. **Arbor Hole** - It is essential that the arbor hole diameter properly matches the blade, and that it is free from distortion. Correct blade flanges (collars) must be used. The inside face of the flanges must be clean and free of debris. An out-of-round arbor condition will cause damage to the blade and the saw.
7. **MAX RPM** - This RPM reference is the maximum safe operating speed for the blade selected. **NEVER** exceed the max RPM on the diamond blade. Exceeding the maximum RPM is dangerous and may cause poor performance and may damage the blade.

BLADE INSTALLATION

1. Use the **blade nut wrench** (Figure 9) supplied with the saw to install the cutting blade.
2. Ensure the capacity of the blade guard matches the diameter of your cutting blade.
3. Using the blade nut wrench, remove the **blade shaft nut** and **outside blade flange**. Install the cutting blade onto the **inside blade flange arbor**. Re-install the outside blade flange and blade shaft nut. Tighten securely. **DO NOT** over tighten.

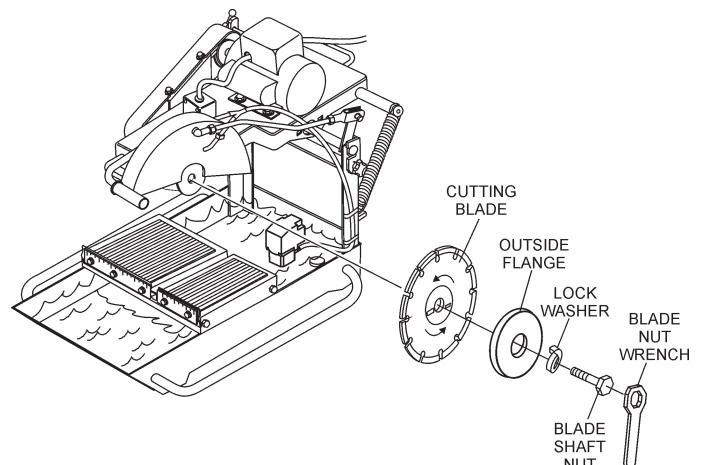

Figure 9. Blade Placement

PRE-SETUP (ELECTRIC)

CONNECTING THE POWER (FIGURE 10)

1. Place the power **ON/OFF** switch (Figure 10) in the **OFF** position (down).

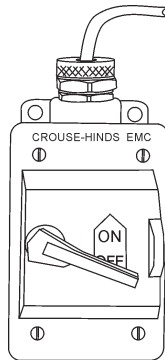

Figure 10. Power ON/OFF Switch (OFF)

2. Connect an extension cord (Figure 13) of adequate current carrying capacity to the power plug on the electric motor.
3. **MAKE CERTAIN** that the correct size extension cord is used. Undersize wires will burn out motors. Use Table 4 to determine the correct extension cord size.

TABLE 4. Extension Cord Sizes				
MOTOR	VOLTAGE VAC	50' LONG	75' LONG	100' LONG
1.5 HP	115	NO. 10	NO. 10	NO. 8
1.5 HP	230	NO. 14	NO. 14	NO. 14
2.0 HP	115	NO. 10	NO. 8	NO. 6
2.0 HP	230	NO. 12	NO. 12	NO. 12

CAUTION



NEVER grab or touch a live power cord (Figure 11) with wet hands, the possibility exists of electrical shock, electrocution, and even **death!**

NEVER use a **damaged** or **worn** extension cable when connecting to a power source. Defective cables may cause damage to the saw's electric motor or electrical shock.

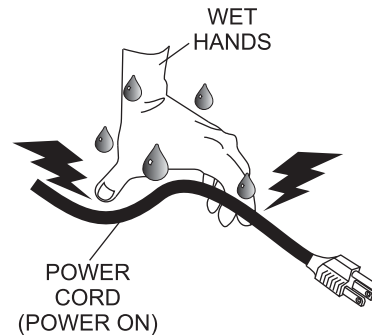

Figure 11. Voltage Selector Switch

4. This unit is shipped from the factory with the **voltage selector switch** (Figure 12) in the 115 VAC position. To change the position of the switch from 115 VAC to 230 VAC, remove the locking bolt and place the switch in the 230 VAC position. Re-install the locking bolt to prevent accidentally flipping the switch.

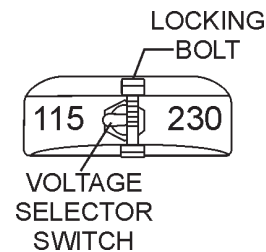

Figure 12. Voltage Selector Switch

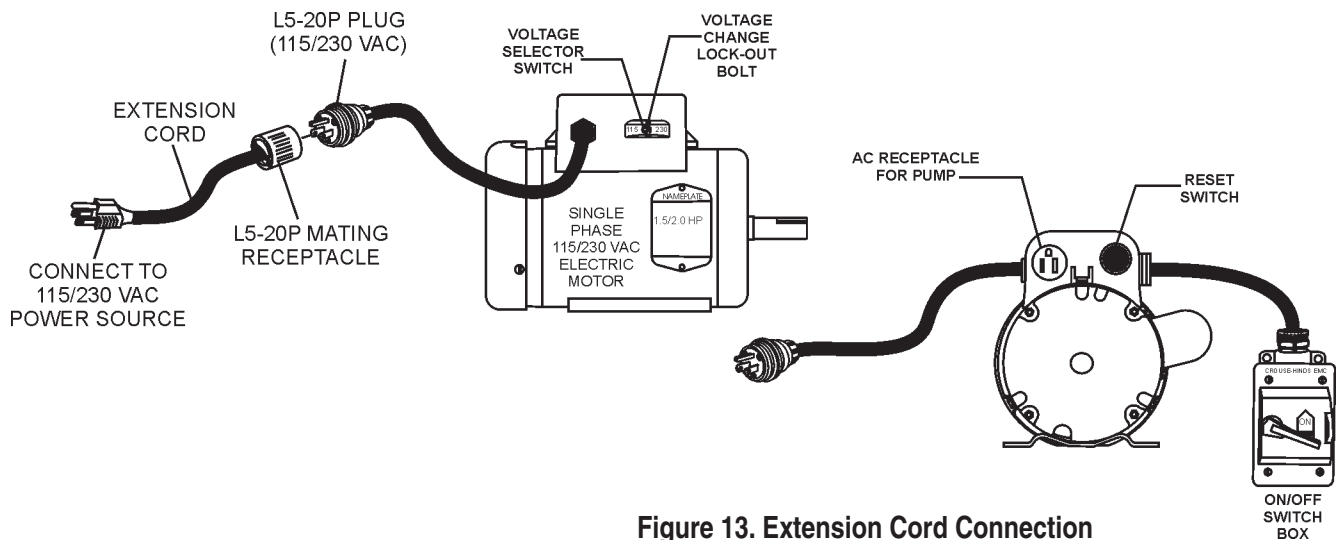

Figure 13. Extension Cord Connection

PRE-SETUP (ELECTRIC)

CAUTION



ALWAYS use a *grounded (3-wire)* extension cord and **MAKE CERTAIN** that the motor is connected to a properly grounded electric circuit. If possible use a ground fault circuit interrupter to protect the operator from possible *electric shock*.

5. Plug the free end of the extension cord into an AC power receptacle. Whenever possible use a GFCI receptacle (Figure 14) to reduce the risk of electrical shock.

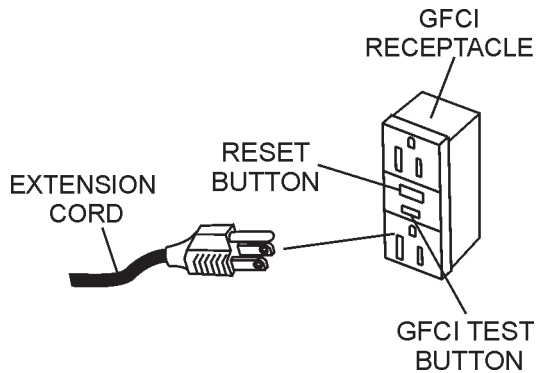

Figure 14. GFCI Receptacle

6. The MP1 masonry saw is now ready for *wet cutting*. The pre-setup procedures for *electric models saws only* is now complete.

DRY CUTTING (ELECTRIC SAWS ONLY)

1. Un-plug the water pump power cord from the outlet receptacle on the electric motor conduit box.

CAUTION



NEVER *dry cut* with the pump connected to a AC power source. Running the pump *dry* will **damage** the pump. Always disconnect the pump's power cord when dry cutting.

2. The MP1 masonry saw is now ready for *dry cutting*. The pre-setup procedures for *electric models saws only* is now complete.

PRE-SETUP (GASOLINE)

PRE-SETUP



WARNING

Whenever cleaning, adjusting or lubricating any part of the saw, **MAKE CERTAIN** to stop the engine and disconnect the spark plug wire from the spark plug.

Assembly (Gasoline Powered Saws Only)

1. Remove the MP1 saw from its container and place it on a suitable table or platform. Make sure the table or platform can support the weight of the saw. The saw platform should be rigid and stationary so that it will not move, sag, or sway due to the vibrations and movements of the saw.
2. If using the MP1 series **support stand kit** (P/NTRAK14SS), attach stand to the under-side of the water tray. Follow the instructions supplied with the support stand kit when attaching it to the water tray.
3. The **gasoline powered** saw uses a **mechanical water pump**. This pump operates by drawing power from the drive V-belts, and has been adjusted and locked for wet cutting operation when shipped from the factory.
4. Fill the water tray with clean fresh water. The **water pump intake (strainer) must always be fully covered by water to operate effectively**. Also, keep the pump intake free of sludge, debris and other materials that may accumulate in the tray.
5. Make certain that the water hose will not come in contact with the blade or interfere with any moving parts. The best location for the water pump/strainer is between the splash shield and the rear of the water tray. This will prevent some of the abrasive particles from flowing through the pump.

CAUTION



ALWAYS position the **strainer** in the water tray in a manner that will allow the free movement of the conveyor cart, and clearance from the cutting blade and cutting action.

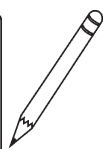
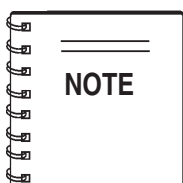

The mechanical water pump is shipped from the factory for **wet cutting** applications.

The MP1 gasoline model utilizes some of the same procedures that are used for the MP1 electric models. Please reference pages 20 and 21 for the below referenced procedures:

- Conveyor Cart Placement
- Blade Selection and Inspection
- Saw Blades
- Blade Installation

DRY CUTTING (GASOLINE ONLY)

To disconnect the **mechanical water pump** from the drive V-belts perform the following:

1. Loosen the 2 hex head cap screws (Figure 15) that secure the pump mount bracket.
2. **Pull** the pump handle **upward** to disengage the pump.
3. Tighten the 2 hex head cap screws that secure the pump mount bracket.

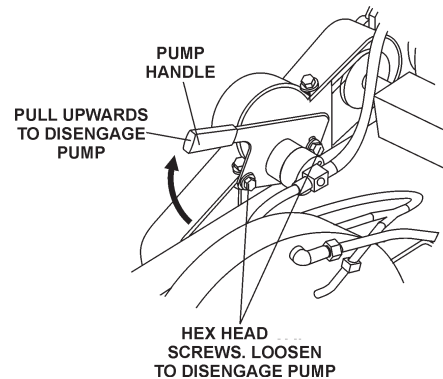

Figure 15. Pump Disengage

WET CUTTING (GASOLINE ONLY)

To connect the **mechanical water pump** to the drive V-belts perform the following:

1. Loosen the 2 hex head cap screws (Figure 16) that secure the pump mount bracket.
2. **Push** the pump handle **downward** to engage the pump.
3. Tighten the 2 hex head cap screws that secure the pump mount bracket.

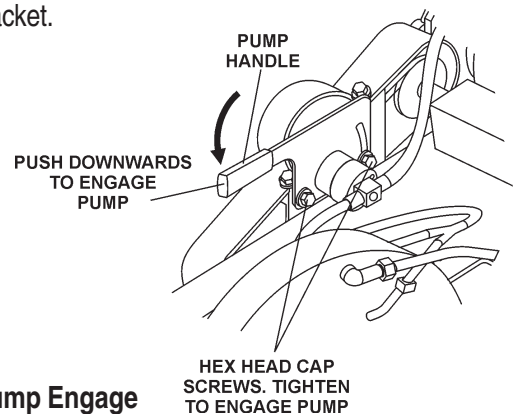

Figure 16. Pump Engage

PRE-SETUP (GASOLINE)

BEFORE STARTING

1. Read safety instructions at the beginning of manual.
2. Clean the saw, removing dirt and dust, particularly the engine cooling air inlet, carburetor and air cleaner.
3. Check the air filter for dirt and dust. If air filter is dirty, replace air filter with a new one as required.
4. Check carburetor for external dirt and dust. Clean with dry compressed air.
5. Check fastening nuts and bolts for tightness.

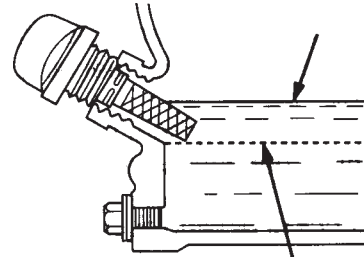

Figure 18. Engine Oil Dipstick (Oil Level)

ENGINE OIL CHECK

1. To check the engine oil level, place the saw on a secure level surface with the engine stopped.
2. Remove the filler dipstick from the engine oil filler hole (Figure 17) and wipe clean.

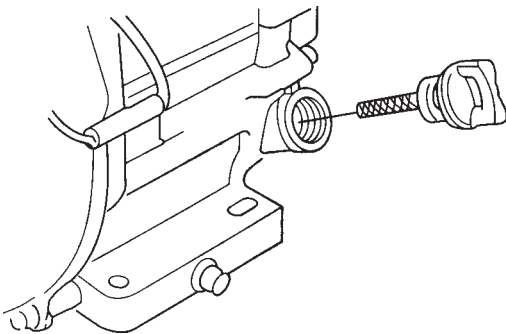

Figure 17. Engine Oil Dipstick (Removal)

3. Insert and remove the dipstick without screwing it into the filler neck. Check the oil level shown on the dipstick.
4. If the oil level is low (Figure 18), fill to the edge of the oil filler hole with the recommended oil type (Table 5). Maximum oil capacity is 0.63 quarts (0.60 liters)

Table 5. Oil Type

Season	Temperature	Oil Type
Summer	25°C or Higher	SAE 10W-30
Spring/Fall	25°C~10°C	SAE 10W-30/20
Winter	0°C or Lower	SAE 10W-10

 **Explosive Fuel**

DANGER



 Motor fuels are highly flammable and can be dangerous if mishandled. **DO NOT** smoke while refueling. **DO NOT** attempt to refuel the pump if the engine is *hot!* or *running*.

FUEL CHECK

1. Remove the gasoline cap located on top of fuel tank.
2. Visually inspect to see if the fuel level is low. If fuel is low, replenish with unleaded fuel.
3. When refueling, be sure to use a strainer for filtration. **DO NOT** top-off fuel. Wipe up any spilled fuel *immediately!*

OPERATION (ELECTRIC)

START-UP ELECTRIC MOTOR

CAUTION



Read and fully understand this manual before **starting or attempting to operate the saw.**

Before starting the saw's electric motor make sure that the **Safety, General Information, Inspection** and **Pre-setup** sections have been completed and understood. **DO NOT** proceed until the above mentioned sections have been completed.

ALWAYS use the **water feed system** unless special **dry cut blades** are being used. If dry cutting is required **disconnect** water pump.

WARNING

ALWAYS wear approved eye and hearing protection before operating the saw.

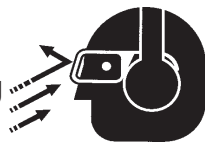

WARNING

NEVER place hands or feet inside the belt guard or blade guard while the engine is running. **ALWAYS** shut the engine down before performing any kind of maintenance



WARNING

NEVER place hands and fingers near the cutting blade. The possibility exist of severe bodily harm if hands and fingers come in contact with rotating saw blade.



WARNING

ALWAYS ensure that the cutting blade has been mounted correctly and that it is raised above the surface you are about to cut.



DANGER

NEVER touch a live power cord with wet hands. The possibility exists of electrical shock, electrocution which could cause severe bodily harm even death.

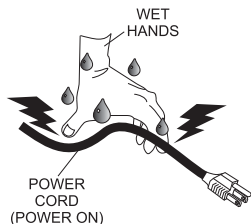

WARNING

NEVER lift the blade guard while the blade is rotating. The possibility exists of **severe bodily harm** if fingers or hands come in contact with the rotating saw blade. Wait for the blade to **stop rotating** before lifting the blade guard.

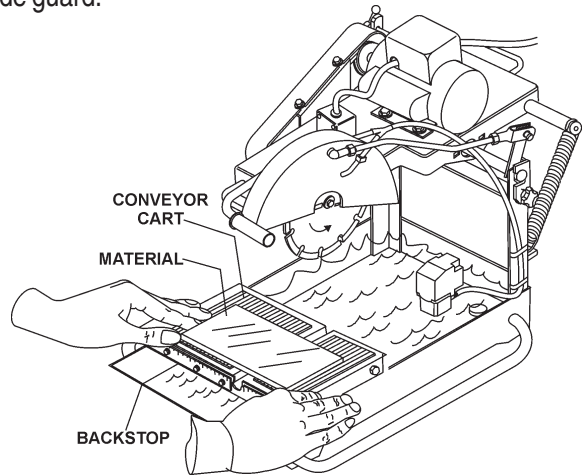

Figure 19. Material Placement

1. Place the material to be cut (Figure 19) on the conveyor cart against the backstop.
2. Place the **mounting plate release/lock lever** (Figure 20) in the **release** position (pull back to release). When releasing the lock, hold on to the mounting plate handle to prevent the plate from rising rapidly, possibly causing the saw to become unstable. Let the plate raise **slowly**.

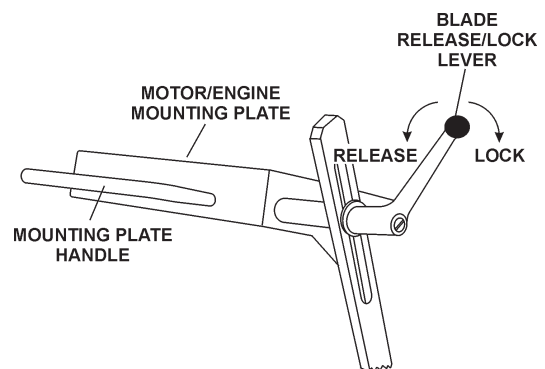

Figure 20. Mounting Plate Release/Lock Lever

OPERATION (ELECTRIC)

- Adjust the cutting depth by pulling up or down on the **Cutting Head Handle** (Figure 21). This saw is designed, and is best utilized as a "**Chop-Saw**". Once the mounting plate release/lock lever is released, the optimum cutting action is attained by using the **Raise/Lower Handle** to rotate down onto the material to be cut. Simultaneously the **conveyor cart is moved slowly forward** to advance the material and cutting action.

A heavy-duty spring supports ergonomic return-to-height action of the cutting head assembly.

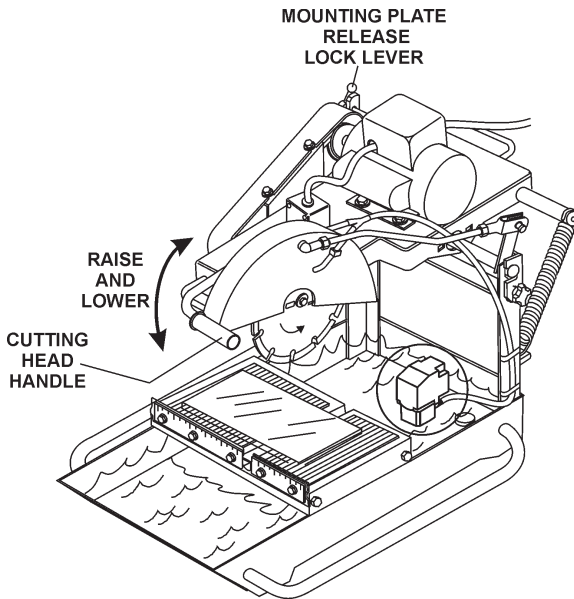

Figure 21. Cutting Head Handle



ALWAYS be alert to the fact that there is a rotating blade on the saw and be extremely aware of your body position - especially your hands in relationship to the rotating blade. The possibility exists of **severe bodily harm even death** if your body comes in contact with the rotating saw blade.

- Turn the power **ON/OFF** switch (Figure 22) to the **ON** position with the blade away from the material to be cut, the cutting blade should begin to rotate. Before cutting remember to follow all safety rules referenced in this manual.

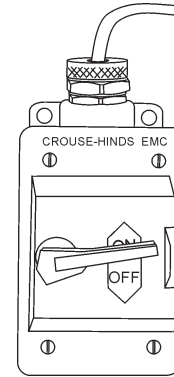

Figure 22. Power ON/OFF Switch (ON)

- Push the **conveyor cart** with the material, slowly and evenly until the cut is complete. Move the cart back and remove the cut pieces.
- Avoid overloading the motor when cutting. However, the electric motors are protected with a manual-reset thermal overload switch that will turn the saw off if the motor is overheated. In the event that the switch is tripped, turn the "**ON/OFF**" switch to the "**OFF**" position and allow the motor to cool before attempting to restart.

SHUTDOWN PROCEDURE

- Place the power **ON/OFF** switch (Figure 23) in the **OFF** position (down).

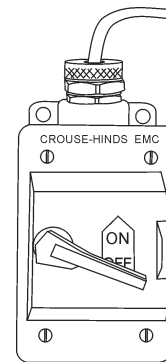

Figure 23. Power ON/OFF Switch (OFF)

- Wait for the cutting blade to stop rotating.
- Disconnect the saw's AC power cord from the power source. **NEVER** leave the saw connected to a power source when unattended. This will prevent accidental starting.
- Using a soft cloth, clean any excess debris or residue that may have accumulated on the saw.
- Store saw in a clean dry location where it will be out of the reach of children.

OPERATION (GASOLINE)

START-UP GASOLINE ENGINE

WARNING



Read and fully understand this manual before **starting or attempting to operate the saw.**

Before starting the saw's electric motor make sure that the **Safety, General Information, Inspection** and **Pre-setup** sections have been completed and understood. **DO NOT** proceed until the above mentioned sections has been completed.

WARNING

NEVER operate the saw in a confined area or enclosed area structure that does not provide ample **free flow of air.**



WARNING

The engine speed has been set at the factory. Changing the governor speed could damage the blade and/or the saw.



ALWAYS use the **water feed system** unless special **dry cut blades** are being used. If dry cutting is required disconnect water pump.

WARNING

ALWAYS wear approved eye and hearing protection before operating the saw.

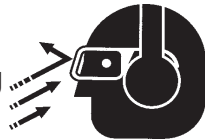

WARNING

NEVER place hands or feet inside the belt guard or blade guard while the engine is running. **ALWAYS** shut the engine down before performing any kind of maintenance service on the saw.



WARNING

NEVER place hands and fingers near the cutting blade. The possibility exist of severe bodily harm if hands and fingers come in contact with rotating saw blade.



WARNING

ALWAYS ensure that the cutting blade has been mounted correctly and that it is raised above the surface you are about to saw.



1. Place the **fuel valve lever** (Figure 24) to the "ON" position.

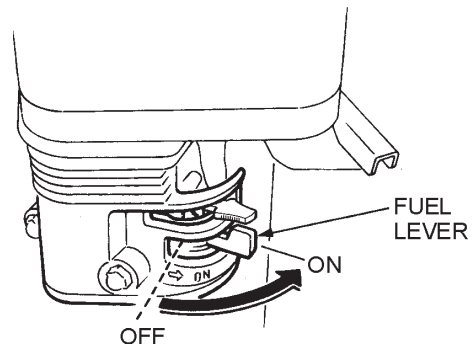

Figure 24. Engine Fuel Valve Lever

2. Place the **Engine ON/OFF switch** (Figure 25) in the "ON" position.

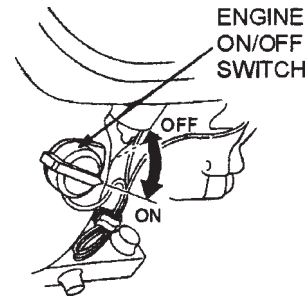
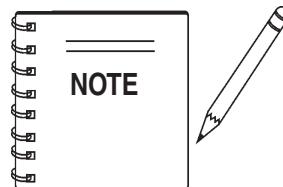

Figure 25. Engine ON/OFF Switch



The **CLOSED** position of the choke lever enriches the fuel mixture for starting a **COLD** engine. The **OPEN** position provides the correct fuel mixture for normal operation after starting, and for restarting a warm engine.

3. Place the **Choke Lever** (Figure 26) in the "CLOSED" position.

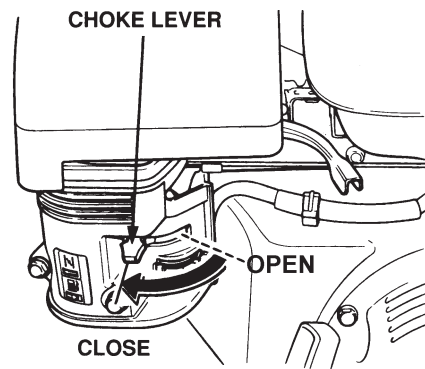

Figure 26. Choke Lever

OPERATION (GASOLINE)

4. Rotate the **throttle lever** (Figure 27) halfway between **fast** and **slow** for starting. All cutting is done at **full throttle**. The engine governor speed is factory set to ensure optimum blade operating speeds.

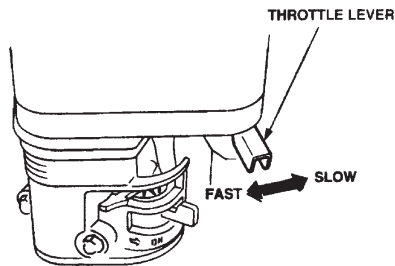

Figure 27. Throttle Lever

5. Grasp the starter grip (Figure 28) and slowly pull it out. The resistance becomes the hardest at a certain position, corresponding to the compression point. Pull the starter grip briskly and smoothly for starting.

CAUTION



DO NOT pull the starter rope all the way to the end. **DO NOT** release the starter rope after pulling. Allow it to rewind as soon as possible.

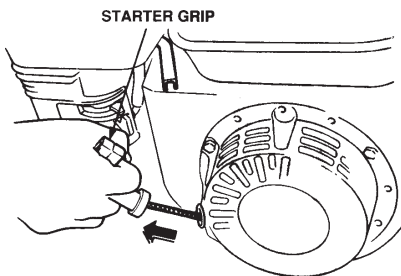

Figure 28. Starter Grip

6. If the engine has started, slowly return the choke lever (Figure 26) to the **"OPEN"** position. If the engine has not started repeat steps 1 through 5.
7. Before the saw is placed into operation, run the engine for several minutes. Check for fuel leaks, and noises that would associate with a loose guards and/or covers.
8. Gradually move the engine throttle lever toward the **fast** position. (**All cutting should be done at full throttle**).
9. Squeeze the water pump **priming bulb** (Figure 29) until water begins to flow through the water lines. If the pump is working correctly, the cutting blade should be covered with a steady water mist. This will keep the blade cool.

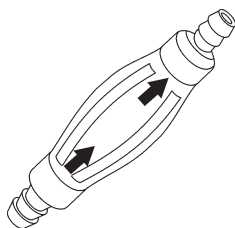

Figure 29. Priming Bulb

WARNING

ALWAYS cut with the saw at **FULL THROTTLE**. Attempting to cut with the saw at less than full throttle could cause the blade to bind or stop abruptly in the slab resulting in serious injury to the operator or others in the area.

DANGER

ALWAYS be alert to the fact that there is a rotating blade on the saw and be extremely aware of your body position - especially your hands in relationship to the rotating blade. The possibility exists of **severe bodily harm even death** if your body comes in contact with the rotating saw blade.

10. Push the **conveyor cart** with the material, slowly and evenly until the cut is complete. Move the cart back and remove the cut pieces.
11. Avoid overloading the engine when cutting. In the event that the engine becomes overloaded, turn the engine **ON/OFF** switch to the **OFF** position and allow the engine to **cool** before attempting to restart.

STOPPING

WARNING



**DO NOT
NEVER**

1. Set the engine throttle lever to **slow** speed and let the engine idle for 3-5 minutes.
2. Turn the engine **ON/OFF** switch to the **"OFF"** position.
3. Place the fuel valve lever in the **closed** position.
4. Let the engine cool.
5. Using a soft cloth, clean any excess debris or residue that may have accumulated on the saw.
6. Store saw in a clean dry location where it will be out of the reach of children.

MAINTENANCE

A good preventive maintenance program of regular inspection and care will increase life and improve the performance of the saw and cutting blades.

WARNING

Whenever cleaning, adjusting, or lubricating any part of the saw, **MAKE CERTAIN** to do the following:

Electric Powered Saws

- Place power **ON/OFF** switch to the **OFF** position.
- Disconnect power cord from AC source.
- **NEVER**

Gasoline Powered Saws

- Turn the engine switch to the "**OFF**" position, disconnect the spark plug wire and secure it away from the spark plug.
- **NEVER**

BASIC MAINTENANCE

1. Tighten loose nuts or screws and replace any cracked or broken parts.
2. Clean the machine frequently. Remove the belt guard and clean the pulleys. The belts and pulleys will wear rapidly if excessive dust builds up.
3. Clean the sludge that accumulates on the bottom of the water tray at least once a day and refill with clean water. It may be necessary to clean the tray out twice a day in heavy cutting. The sludge is abrasive and will shorten the life of the water pump and blades.
4. After each day's use, clean the sludge from the bottom of the tray and run clean water through the water pump and water hoses. This extends pump and blade life.
5. Lubricate the blade adjustment rod after every eight (8) hours of use.
6. Check the spindle bolt for tightness periodically.
7. Keep the drive belts tight. It is very important to replace worn belts as soon as possible.
 - A. **Electric Powered Saws** - To adjust belt tension, loosen the four (4) motor mounting bolts and remove the belt guard. Tighten the two (2) adjusting nuts on the back of the motor plate to increase the tension. Proper belt tension is 4-5 lbs. of force with approximately 3/16" of belt deflection measured at a point midway between the pulleys. Tighten the motor mounting bolts and re-attach the belt guard.

- B. **Gasoline Powered Saws** - To adjust belt tension, loosen the four (4) jackshaft mounting bolts and remove the belt guard. Screw the adjusting bolt back to increase the tension. Proper belt tension is 4-5 lbs. of force with approximately 1/8" of belt deflection measured at a point halfway between the pulleys.

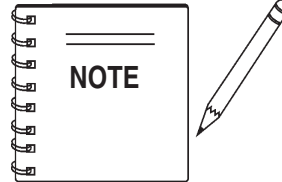

It is very important that the jackshaft and blade arbor **remain parallel** to each other. This can be accomplished by using the adjusting bolt located on the engine mounting plate to help keep the jackshaft from cocking.

Tighten the jackshaft bearing mounting bolts (4) that are located under the weldment. Next, loosen the (4) engine mounting bolts and remove the belt guard. Tighten the (2) nuts on the engine tensioning bolts that are at the rear of the weldment. Proper belt tension is 4-5 lbs. of force with approximately 1/8" of belt deflection measured at a point halfway between the pulleys. Tighten the engine mounting bolts.

Pull on the recoil to make certain everything moves smoothly and freely. If the recoil pulls hard, the belts are probably adjusted a little **too tight**. Belt tensions should be readjusted before continuing. Attach the belt guards to the saw. Make certain that the guards do not come in contact with the belts or each other. There are slots in the guard mounting plates so adjustments can be made if necessary. Tighten all bolts on the guards and their mounts.

8. **MAKE CERTAIN** that the cutting head is aligned properly. Misalignment can adversely affect blade life.
9. The blade flanges must have a diameter of 4". Undersize flanges will reduce blade life and cause breakage. Therefore, they should be replaced at once.
10. Cutting blades must fit the arbor snugly. This is very important with diamond blades as pounding will occur and serious blade damage can result. If the arbor shoulder of the inner blade flange is grooved from blade slippage, the flange must be replaced.
11. Inspect the conveyor cart periodically. Replace the wood insert and wheels when necessary.
12. Lubricate spindle bearings after each day's operation. When dry cutting, grease bearings several times during the day's operation to protect them from the dust.

13. Replace the spindle bearings as soon as they begin to make any strange noises. Worn bearings can destroy blades very quickly.
14. Grease pivot bearings periodically.

CUTTING HEAD ALIGNMENT (BLADE)

Make certain the **cutting head** is aligned properly. Misalignment can adversely affect blade life. The motor/engine plate is slotted so adjustment to the blade can be made as needed. The left side has vertical slots, and the right side has horizontal slots. To adjust the cutting head either vertical or horizontally perform the following:

VERTICAL ADJUSTMENT

Remove the motor or engine from the mounting plate. Loosen the pivot bearing bolts (2) on the left side of the mounting plate. Move the pivot bearing to the extreme top of the slots in the mounting plate. Thread a 3/8-16 bolt (adjusting bolt) down through the hole in the top of the mounting plate. Tighten the bolt against the bearing.

This will raise the mounting plate. Continue to tighten the bolt until the blade is perpendicular to the conveyor cart. Tighten the pivot bearing bolts. Remove the adjusting bolt and reassemble.

HORIZONTAL ADJUSTMENT

Loosen the pivot bearings (2) on the right-side of the mounting plate. Slide the pivot bearing forward or backwards as needed, until the blade is parallel with the conveyor cart. Tighten the pivot bearing bolts.

BEARING LUBRICATION CARE

There are two (2) grease points (Figure 30) for the MP1 **gasoline** model saw. Use only Premium Lithium 12 based Grease, conforming to NLG1 Grade #2 consistency. Grease **daily**.

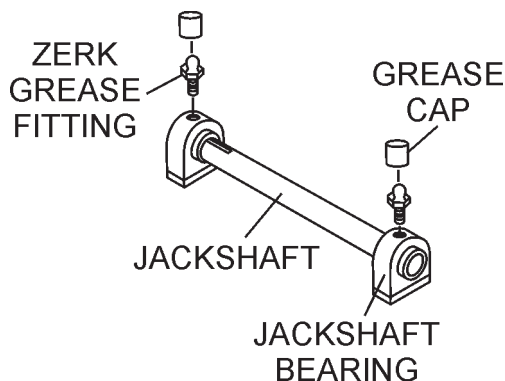
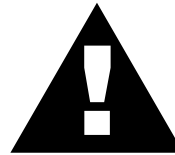

Figure 30. Zerk Fittings (Lubrication)

CAUTION:



When loosening the handle lock, hold onto the front of the motor/engine plate handle to prevent the plate from raising rapidly, possible causing the saw to become unstable. Let the plate raise slowly. When removing the spring from the pivot shaft, **MAKE CERTAIN** the motor/engine plate is supported to prevent the cutting head from dropping.

CUTTING HEAD REMOVAL

To remove the cutting head (Figure 31) perform the following:

1. Loosen the knobs (2) located on each side of uprights.
2. Slide the hooks (2) up and away from the pivot shaft.
3. Remove the handle lock that fastens the blade height adjusting arm to the motor/engine plate. This is accomplished by simply removing the cotter pin.
4. Disconnect the spring from the pivot shaft by raising the cutting head until the tension is relieved from the spring.
5. To reassemble the cutting head, reverse these steps.

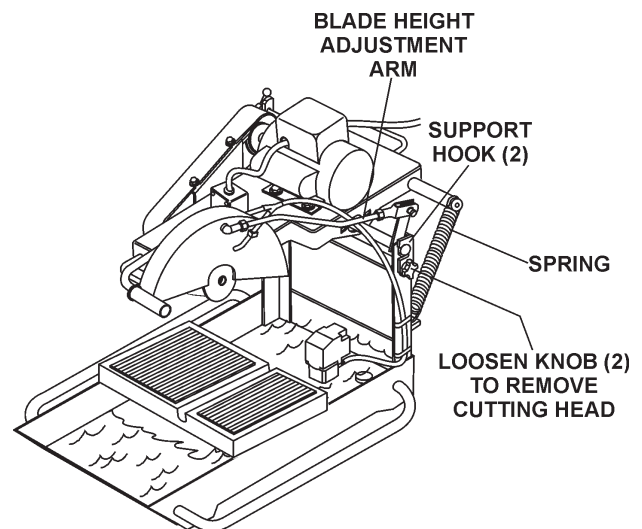

Figure 31. Cutting Head Removal

MP1 — MAINTENANCE (ENGINE)

ENGINE MAINTENANCE

Perform engine maintenance procedures as referenced by Table 6 below:

Table 6. Engine Maintenance Schedule							
DESCRIPTION (3)	OPERATION	BEFORE	FIRST MONTH OR 10 HRS.	EVERY 3 MONTHS OR 25 HRS.	EVERY 6 MONTHS OR 50 HRS.	EVERY YEAR OR 100 HRS.	EVERY 2 YEARS OR 200 HRS.
Engine Oil	CHECK	X					
	CHANGE		X				
Air Cleaner	CHECK	X					
	CHANGE			X (1)			
All Nuts & Bolts	Re-tighten If Necessary	X					
Spark Plug	CHECK-CLEAN				X		
	REPLACE						X
Cooling Fins	CHECK				X		
Spark Arrester	CLEAN					X	
Fuel Tank	CLEAN					X	
Fuel Filter	CHECK					X	
Idle Speed	CHECK-ADJUST					X (2)	
Valve Clearance	CHECK-ADJUST						X (2)
Fuel lines	CHECK	Every 2 years (replace if necessary) (2)					

(1) Service more frequently when used in **DUSTY** areas.

(2) These items should be serviced by your servic dealer, unless you have the proper tools and are mechanically proficient. Refer to the HONDA shop Manual for service procedures

(3) For commercial use, log hours of operation to determine proper maintenance intervals.

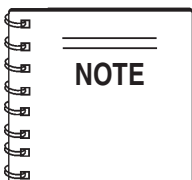

Reference manufacturer engine manual for specific servicing instructions.

MP1 — MAINTENANCE (ENGINE)

MAINTENANCE

Perform the engine maintenance procedures as indicated below:

DAILY

- Thoroughly remove dirt and oil from the engine and control area. Clean or replace the air cleaner elements as necessary. Check and retighten all fasteners as necessary. Check the spring box and bellows for oil leaks. Repair or replace as needed.

WEEKLY

- Remove the fuel filter cap and clean the inside of the fuel tank.
- Remove or clean the filter at the bottom of the tank.
- Remove and clean the spark plug (Figure 32), then adjust the spark gap to 0.028 ~0.031 inch (0.6~0.7 mm). This unit has electronic ignition, which requires no adjustments.

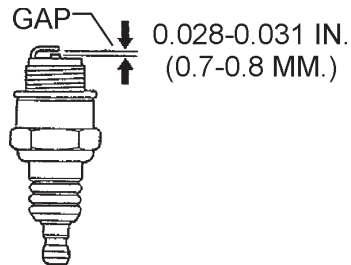

Figure 32. Spark Plug Gap

ENGINE OIL

- Drain the engine oil when the oil is **warm** as shown in Figure 33.
- Remove the oil drain bolt and sealing washer and allow the oil to drain into a suitable container.
- Replace engine oil with recommended type oil as listed in Table 5. Engine oil capacity is 0.63 quarts (0.60 liters). **DO NOT** overfill.
- Install drain bolt with sealing washer and tighten securely.

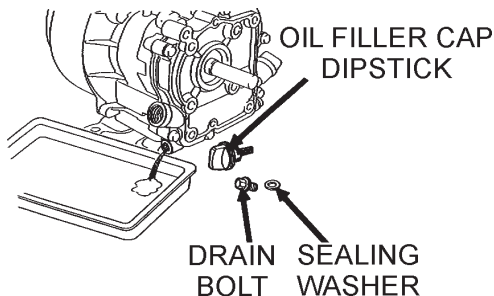
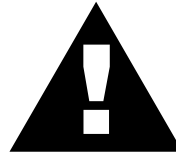

Figure 33. Engine Oil (Draining)

DANGER:



DO NOT use gasoline as a cleaning solvent, because that would create a risk of fire or explosion.

ENGINE AIR CLEANER

- Remove the air cleaner cover and foam filter element as shown in Figure 34.
- Tap the paper filter element (Figure 34) several times on a hard surface to remove dirt, or blow compressed air [not exceeding 30 psi (207 kPa, 2.1 kgf/cm²)] through the filter element from the air cleaner case side. **NEVER** brush off dirt. Brushing will force dirt into the fibers. Replace the paper filter element if it is excessively dirty.
- Clean foam element in warm, soapy water or nonflammable solvent. Rinse and dry thoroughly. Dip the element in clean engine oil and completely squeeze out the excess oil from the element before installing.

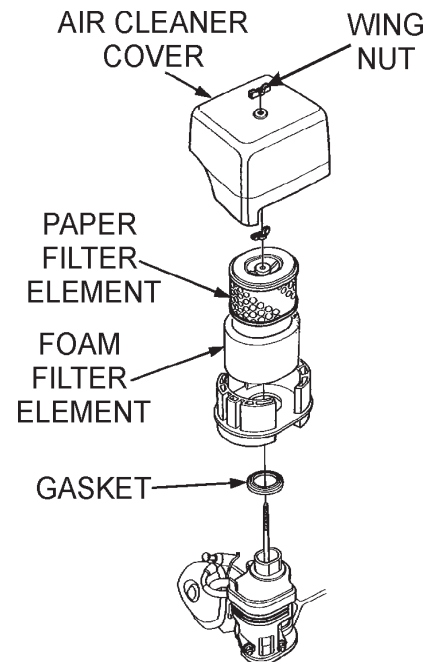
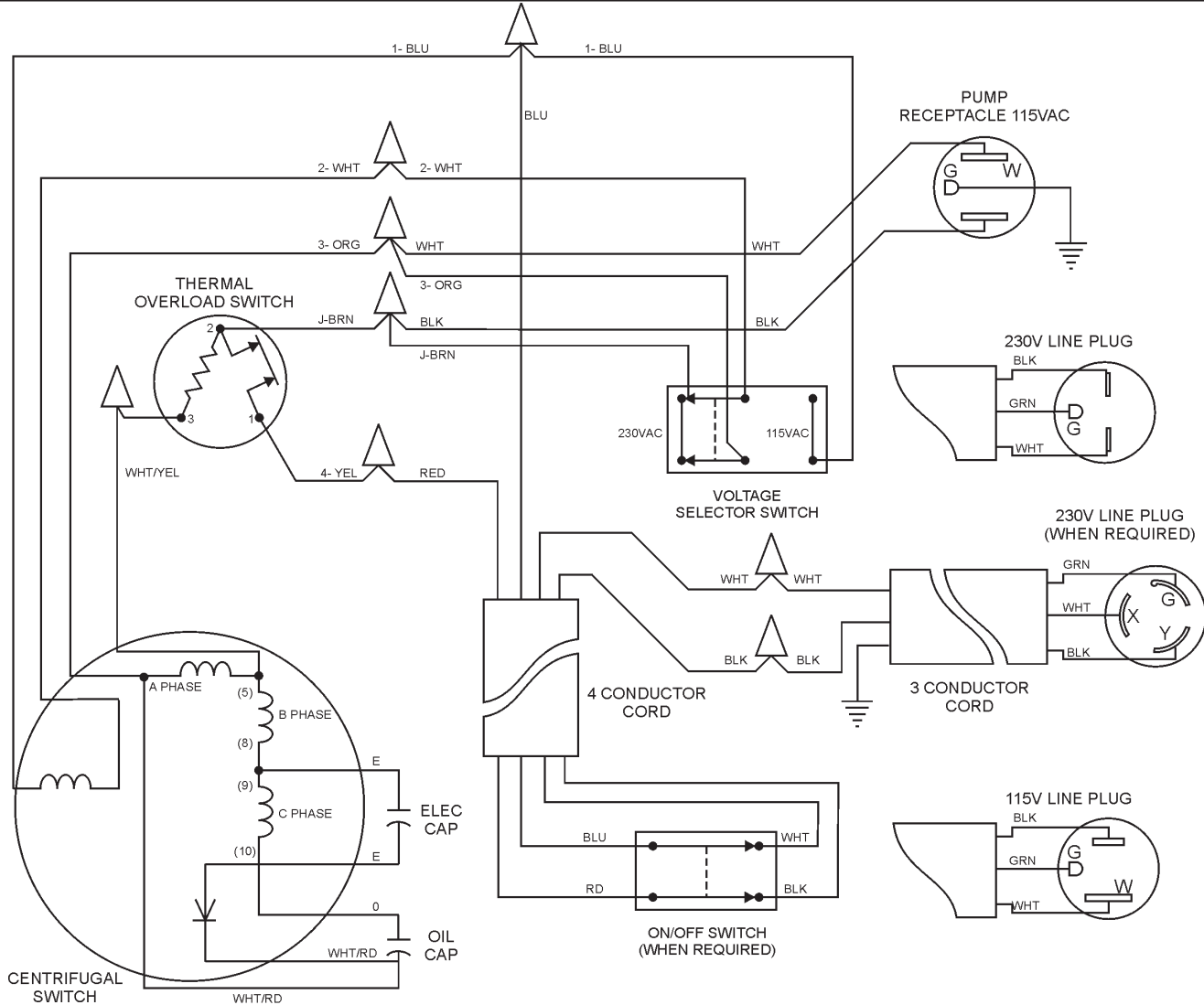

Figure 34. Engine Air Cleaner

WIRING DIAGRAM - ELECTRIC MOTOR



NOTES:

1. CONNECTIONS ARE SHOWN FOR CC ROTATION FACING END OPPOSITE SHAFT EXTENSION (STD). FOR CW ROTATION, INTERCHANGE (5) AND (8) INTERNALLY, AND INTERCHANGE (9) AND (10) INTERNALLY.
2. MULTIPLE CAPACITORS ARE CONNECTED IN PARALLEL UNLESS OTHERWISE SPECIFIED.
3. USE 2PDT VOLTAGE CHANGE SWITCH. CONTACTS ARE SHOWN IN **HIGH-VOLT** POSITION. VIEW IS FROM TERMINAL SIDE.
4. 115V SIDE OF SWITCH GUARD SHOULD BE ON THE SAME SIDE OF SWITCH AS ANTI-ROTATION SLOT.
5. LEAD COLORS ARE OPTIONAL. LEADS MUST **ALWAYS** BE NUMBERED AS SHOWN.

Figure 34. Electric Motor Wiring Diagram

COLOR CODE			
	WIRE COLOR		WIRE COLOR
BLK	BLACK	RD	RED
BLU	BLUE	WHT	WHITE
BR	BROWN	Y	YELLOW
GRN	GREEN	LB	LIGHT BLUE
GR	GRAY	LG	LIGHT GREEN
V	VIOLET	ORG	ORANGE
P	PINK		

TROUBLESHOOTING - BLADE

TABLE 7. BLADE TROUBLESHOOTING

SYMPTOM	POSSIBLE PROBLEM	SOLUTION
Blade slows or stops cutting, still remains on blade	Blade too hard for the material being cut?	Consult Dealer or STOW for correct blade. Try cutting very soft material (sandstone, silica brick, cinder block) to "Redress" the blade.
	Engine torque diminished because of loose V-belt?	Tighten and/or replace V-Belt.
	Insufficient Engine power?	Check throttle setting. Check Engine horsepower.
	Improper direction of rotation?	Check that the blade is properly oriented and rotational arrow points in a "Down-Cutting" direction.
	Blade is slipping on the blade shaft?	Check that the blade & flange pin are properly installed on the blade shaft.
Blade does not cut straight and/or true.	Blade being used on misaligned saw?	Check blade shaft bearings and alignment integrity.
	Blade is excessively hard for the material being cut?	Check specification of the blade with the material being cut. Consult Dealer or STOW for information.
	Blade improperly mounted on arbor shoulders and flanges?	Ensure blade is properly affixed on the blade shaft.
	Excessive force applied to blade while cutting?	DO NOT force the blade in the cut. Apply a slow and steady pace when sawing.
Blade discoloring, crackling and/or wearing excessively.	Blades too hard for the material being cut?	Consult Dealer or STOW for correct blade. Try cutting very soft material (sandstone, silica brick, cinder block) to "Redress" the blade.
	Blade improperly mounted on arbor shoulders and flanges?	Ensure blade is properly affixed on the blade shaft.
	Blade not receiving enough cooling water or air?	Ensure proper flow & volume of water is provided for wet cutting blades. Ensure sufficient cooling air is circulated about a dry cutting blade.
	Arbor hole out of round?	Ensure blade is properly affixed on the blade shaft.
	Incorrect blade chosen for material being cut?	Check specification of the blade with the material being cut. Consult Dealer or STOW for information.
	Excessive force applied to blade while cutting?	DO NOT force the blade in the cut. Apply a slow and steady pace when sawing.

TROUBLESHOOTING - ELECTRIC MOTOR

TABLE 8. TROUBLESHOOTING (ELECTRIC MOTOR)

SYMPTON	POSSIBLE PROBLEM	SOLUTION
Saw does not run when power is switch on.	Power cord plugged in?	Check that saw is properly connected to a power source.
	Defective power cord?	Replace power cord.
	Main power switch on saw defective?	Check and replace switch if necessary.
	Loose electrical connections?	Have electrical system checked by a qualified licensed electrician.
	Defective motor?	Check motor and replace if necessary.
Poor saw performance little power.	Power cord/extension cable too long?	Use a power cord/extension cable of rated length. See Table 4.
	Power source is insufficient?	Check electrical circuit. Circuit must be cable of supplying 20 amps minimum.
	Does motor run at rated speed?	Check motor and replace if necessary.
Motor stops (power cuts out)	Too much exerted while cutting?	Exert less pressure when cutting.
	Incorrect saw blade?	Use a saw blade which corresponds to the material being cut.
	Defective electrical system?	Have electrical system checked by a qualified licensed electrician.

TROUBLESHOOTING - GASOLINE ENGINE

TABLE 9. ENGINE TROUBLESHOOTING

SYMPTOM	POSSIBLE PROBLEM	SOLUTION
Difficult to start		
Fuel is available but spark plug will not ignite. (Power available at high tension cable).	Ignition plug being bridge?	Check ignition system.
	Carbon deposit at ignition?	Clean or replace ignition.
	Short circuit due to defective insulators?	Replace insulators.
	Improper spark gap?	Set spark plug gap to the correct gap.
Fuel is available but spark plug will not ignite. (Power NOT available at high tension cable).	Short circuit at stop switch?	Check stop switch circuit. Replace stop switch if defective.
	Ignition coil defective?	Replace ignition coil.
Fuel is available and spark plug ignites (compression normal).	Muffler clogged with carbon deposits?	Clean or replace muffler.
	Mixed fuel quality is inadequate?	Check fuel to oil mixture.
	Fuel in use inadequate (water, dust)?	Flush fuel sytem and replace with fresh fuel.
	Air Cleaner clogged?	Clean or replace air cleaner.
Fuel is available and spark plug ignites (compression low).	Defective cylinder head gasket?	Tighten cylinder head bolts or replace head gasket.
	Cylinder worn?	Replace cylinder.
	Spark plug loose?	Tighen spark plug.
Operation not satisfactory		
Not enough power available (compression normal, no miss-firing).	Air cleaner clogged?	Clean or replace air cleaner.
	Air in fuel line?	Bleed (remove air) from fuel line.
	Fuel level in carbureator float chamber improper?	Adjust carbureator float
	Carbon deposits in cylinder?	Clean or replace cylinder
Not enough power available (compression normal, miss-firing).	Ignition coil defective?	Flush fuel sytem and replace with fresh fuel.
	Ignition plug often shorts?	Replace ignition wires, clean ignition.
	Fuel in use inadequate (water, dust)?	Flush fuel sytem and replace with fresh fuel.
Engine overheats.	Excessive carbon depostion in combustion chamber?	Clean or replace crankcase.
	Exhaust or muffler clogged with carbon.	Clean or replace muffler.
	Spark plug heat value incorrect?	Replace spark plug with correct type spark plug.

TROUBLESHOOTING - GASOLINE ENGINE

TABLE 7. ENGINE TROUBLESHOOTING (Continued)

SYMPTOM	POSSIBLE PROBLEM	SOLUTION
Operation not satisfactory		
Rotational speed fluctuates.	Governor adjustment improper?	Adjust governor to correct lever.
	Governor spring defective?	Clean or replace ignition.
	Fuel flow erratic?	Check fuel line.
Recoil starter not working properly.	Dust in rotating part?	Clean recoil starter assembly.
	Spring spring failure?	Replace sprial spring.

EXPLANATION OF CODE IN REMARKS COLUMN

The following section explains the different symbols and remarks used in the Parts section of this manual. Use the help numbers found on the back page of the manual if there are any questions.

NOTICE

The contents and part numbers listed in the parts section are subject to change **without notice**. Multiquip does not guarantee the availability of the parts listed.

SAMPLE PARTS LIST

NO.	PART NO.	PART NAME	QTY.	REMARKS
1	12345	BOLT.....	1	INCLUDES ITEMS W/%
2%		WASHER, 1/4 IN.....		NOT SOLD SEPARATELY
2%	12347	WASHER, 3/8 IN....	1	MQ-45T ONLY
3	12348	HOSE		A/R ...MAKE LOCALLY
4	12349	BEARING	1	S/N 2345B AND ABOVE

NO. Column

Unique Symbols — All items with same unique symbol

(@, #, +, %, or >) in the number column belong to the same assembly or kit, which is indicated by a note in the “Remarks” column.

Duplicate Item Numbers — Duplicate numbers indicate multiple part numbers, which are in effect for the same general item, such as different size saw blade guards in use or a part that has been updated on newer versions of the same machine.

NOTICE

When ordering a part that has more than one item number listed, check the remarks column for help in determining the proper part to order.

PART NO. Column

Numbers Used — Part numbers can be indicated by a number, a blank entry, or TBD.

TBD (To Be Determined) is generally used to show a part that has not been assigned a formal part number at the time of publication.

A blank entry generally indicates that the item is not sold separately or is not sold by Multiquip. Other entries will be clarified in the “Remarks” Column.

QTY. Column

Numbers Used — Item quantity can be indicated by a number, a blank entry, or A/R.

A/R (As Required) is generally used for hoses or other parts that are sold in bulk and cut to length.

A blank entry generally indicates that the item is not sold separately. Other entries will be clarified in the “Remarks” Column.

REMARKS Column

Some of the most common notes found in the “Remarks” Column are listed below. Other additional notes needed to describe the item can also be shown.

Assembly/Kit — All items on the parts list with the same unique symbol will be included when this item is purchased.

Indicated by:
 “INCLUDES ITEMS W/(unique symbol)”

Serial Number Break — Used to list an effective serial number range where a particular part is used.

Indicated by:
 “S/N XXXXX AND BELOW”
 “S/N XXXX AND ABOVE”
 “S/N XXXX TO S/N XXX”

Specific Model Number Use — Indicates that the part is used only with the specific model number or model number variant listed. It can also be used to show a part is NOT used on a specific model or model number variant.

Indicated by:
 “XXXXX ONLY”
 “NOT USED ON XXXX”

“Make/Obtain Locally” — Indicates that the part can be purchased at any hardware shop or made out of available items. Examples include battery cables, shims, and certain washers and nuts.

“Not Sold Separately” — Indicates that an item cannot be purchased as a separate item and is either part of an assembly/kit that can be purchased, or is not available for sale through Multiquip.

SUGGESTED SPARE PARTS

MP1 MASONRY SAW 1 TO 3 UNITS

Electric Motor Models

Qty.	P/N	Description
2	15503	KNOB, COMFORT GRIP
2	10136	WASHER, FLAT 3/8
2	0166 A	WASHER, LOCK 3/8
1	23783-001	WRENCH, HEX 3/4
4	521003	V-BELT, ELECTRIC MOTOR AX-34
1	23843-001	WATER PUMP, ELECTRIC MOTOR
4 FT.	23867-002	VINYL WATER TUBING
1	24301-501	CONVEYOR CART
2	29713-001	BLADE SHAFT BEARING
2	8136	BLADE SCREW
2	5054 A	WASHER, LOCK
2	23832-001	OUTER BLADE FLANGE
2	23846-001	OUTER BLADE FLANGE
2	29719-001	HANDLE LOCK

MP1 MASONRY SAW 1 TO 3 UNITS

Gasoline Engine Model

Qty.	P/N	Description
2	15503	KNOB, COMFORT GRIP
2	28321-001	BLADE SHAFT BEARING
2	8136	BLADE SCREW
2	5054 A	WASHER, LOCK
2	10136	WASHER, FLAT 3/8
2	0166 A	WASHER, LOCK 3/8
1	23783-001	WRENCH, HEX 3/4
4	16779-012	V-BELT, DRIVE, 3VX250
4	16779-006	V-BELT, JACK SHAFT 3VX300
1	25807-502	WATER PUMP KIT
4 FT.	23867-002	VINYL WATER TUBING
1	25685-001	STRAINER
1	24301-501	CONVEYOR CART
2	23832-001	OUTER BLADE FLANGE
2	23846-001	OUTER BLADE FLANGE
2	29719-001	HANDLE LOCK
3	17210ZE1505	ELEMENT, AIR CLEANER
3	9807956846	SPARK PLUG
1	17620ZH7023	CAP, FUEL FILLER
1	28462ZH8003	ROPE, RECOIL STARTER

NAME PLATE AND DECALS

NAMEPLATE AND DECALS

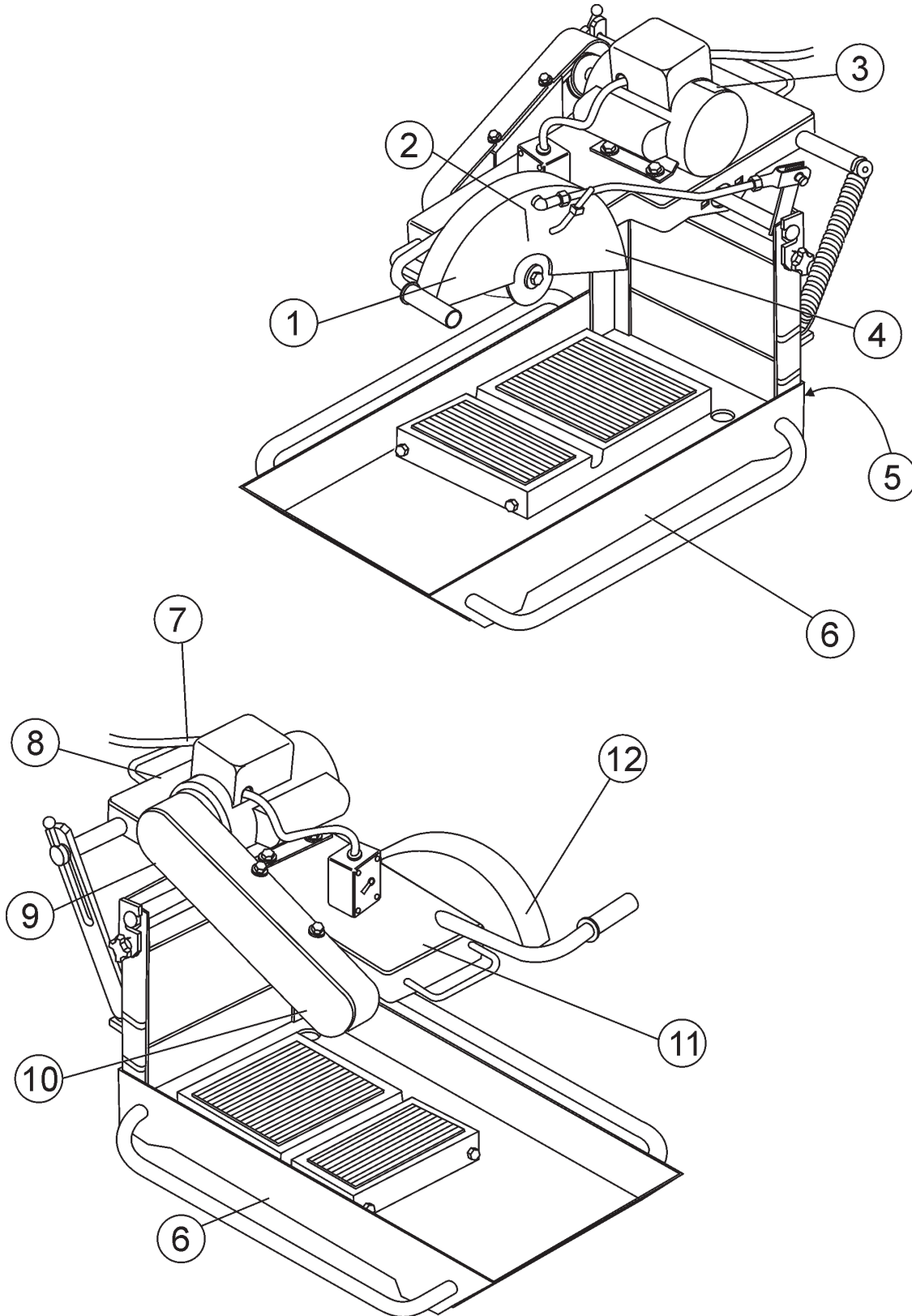

NAME PLATE AND DECALS

NAMEPLATE AND DECALS

<u>NO.</u>	<u>PART NO.</u>	<u>PART NAME</u>	<u>QTY.</u>	<u>REMARKS</u>
1	25249-001	DECAL, KEEP HANDS CLEAR	1	
2	25678	DECAL, CCW ROTATION	1	
3	25139-001	DECAL, EXTENSION CORD SIZE	1	ELECTRIC MODELS ONLY
4	22972-004	DECAL, MQ DIAMONDBACK BLACK	1	
5	13118	DECAL, POWDER COATED	1	
6	38240	DECAL, MP1	2	
7	25215-001	DECAL, ELECTRIC CORD WARNING	1	ELECTRIC MODELS ONLY
8		PLATE, MODEL/SERIAL NUMBER	1	CONTACT PARTS DEPT.
9	25349-001	DECAL, GUARD WARNING	1	
10	38239	DECAL, MULTIQUIP	1	
11	20525	DECAL, PROP 65	1	
12	22122-001	DECAL, SERIOUS INJURY WARNING	1	

TRAY ASSY.

TRAY ASSY.

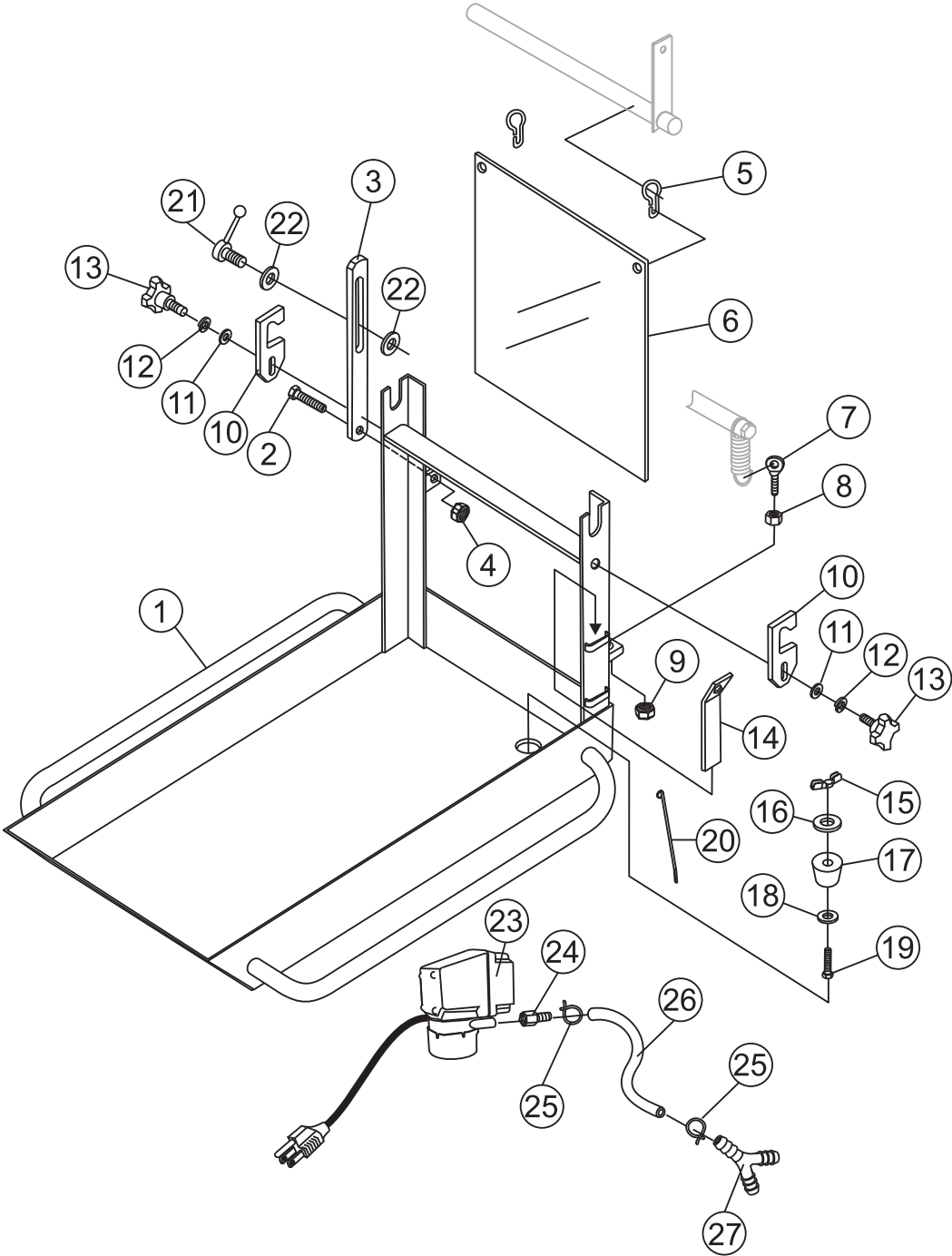

TRAY ASSY.

TRAY ASSY.

<u>NO.</u>	<u>PART NO.</u>	<u>PART NAME</u>	<u>QTY.</u>	<u>REMARKS</u>
1	29695-351	TRAY, WATER	1	
2	0105	SCREW, HHC 5/16 - 18 X 1-1/2	1	
3	29685-001	ARM, BLADE HEIGHT ADJST.	1	
4	08233-005	NUT, LOCK 5/16 - 18 GRIPCO	1	
5	23853-001	SNAP HOOK, SHOWER CURTAIN	2	
6	23848-001	CURTAIN, SPLASH	1	
7	23858-001	BOLT, WIRE EYE	1	
8	1456	NUT, HEX FINISH 3/8 - 16	1	
9	08233-006	NUT, LOCK 3/8 - 16 GRIPCO	1	
10	29684-001	HOOK	2	
11	10136	WASHER, FLAT 3/8	2	
12	0166 A	WASHER, LOCK 3/8	5	
13	15503	KNOB, COMFORT GRIP	2	
14	23783-001	WRENCH, HEX 3/4	1	
15	2509	NUT, WING 1/4 - 20 PLTD	1	
16	12391-004	WASHER, FLAT 1/4 AN970-4	1	
17	23847-001	RUBBER STOPPER	1	
18	0948	WASHER, FLAT SAE 1/4	1	
19	5277	SCREW, HHC 1/4 - 20 X 1-1/2	1	
20	1622	TIE, CABLE	1	
21	29719-001	HANDLE LOCK	1	
22	0447	WASHER, FLAT SAE 1/2	2	
23	23843-001	WATER PUMP, ELECTRIC	1	
24	26077-001	FITTING, BRASS 6 BARB 1/4FP	1	
25	12694-001	HOSE CLAMP	2	
26	23867-002	TUBING, VINYL 5/16	4 FT.	
27	14233-002	Y-FITTING	1	

CART ASSY.

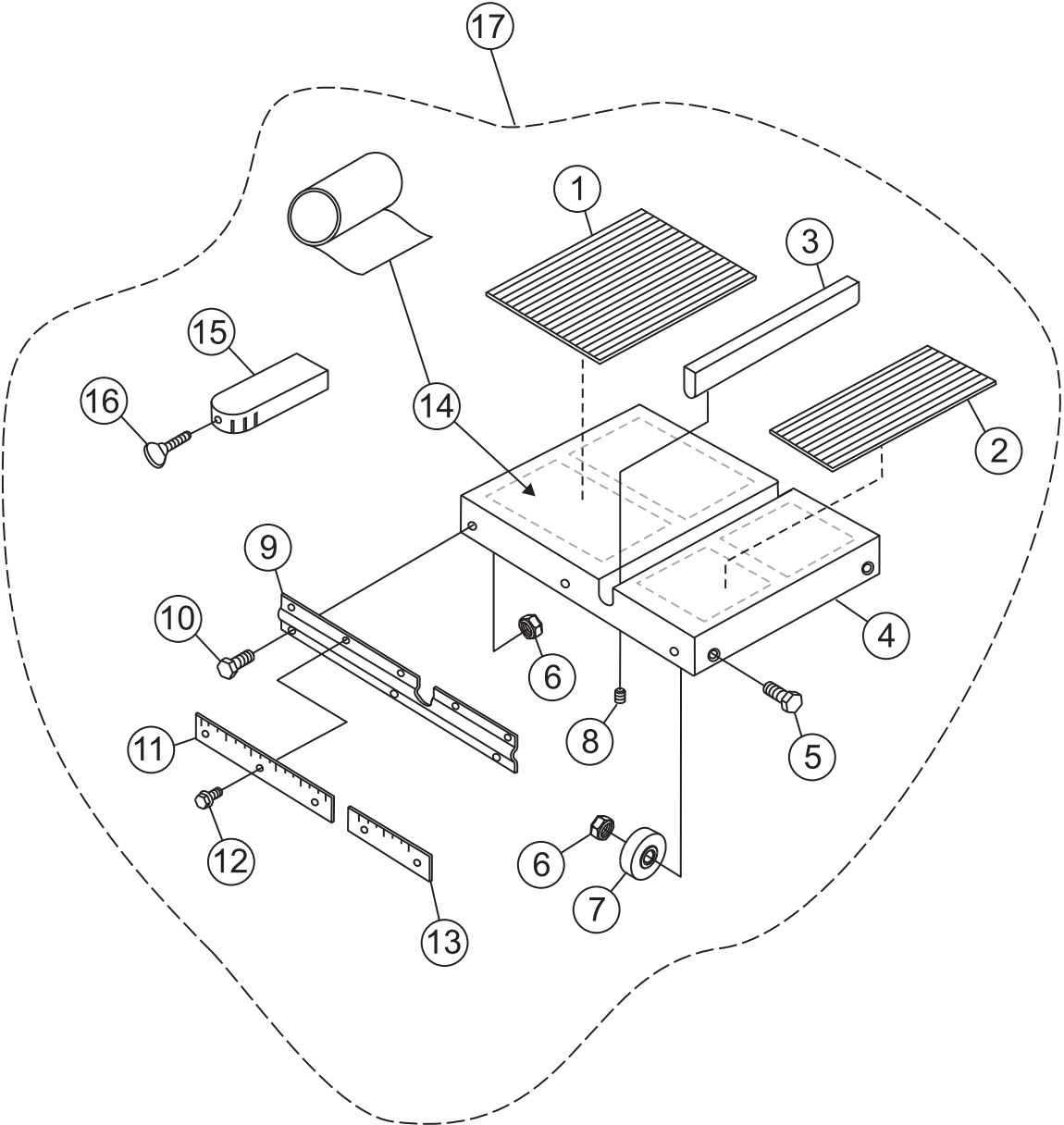

CART ASSY.

CART ASSY.

<u>NO.</u>	<u>PART NO.</u>	<u>PART NAME</u>	<u>QTY.</u>	<u>REMARKS</u>
1*	23804-002	MAT, RUBBER V-RIB 11.91 X 10.10	1	
2*	23804-001	MAT, RUBBER V-RIB 5.79 X 10.10	1	
3*	24569-001	INSERT	1	
4*	24289-001	CART, CONVEYOR	1	
5*	0730	SCREW, HHC 1/4 - 20 X 1	4	
6*	08233-004	NUT, LOCK 1/4 - 20 GRIPCO	7	
7*	23793-001	WHEEL, CONVEYOR CART	4	
8*	23796-001	SCREW, RD HD	2	
9*	24300-001	SIDE CONVEYOR	1	
10*	0131 A	SCREW, HHC 1/4 - 20 X 3/4	3	
11*	23807-001	RULER, R-L 12 IN.	1	
12*	23866-001	SCREW, HHST 10 32 X 1/2	5	
13*	23808-001	RULER, SHORT L-R X 5 IN.	1	
14*	26076-301	TAPE, ROLL ADHESIVE TRNSFR	7 FT.	
15*	24288-001	GUIDE, CUTTING	1	
16*	08622-012	SCREW, THUMB 5/16 - 18 X 1-1/2	1	
17	24301-501	CART ASSEMBLY	1 INCLUDES ITEMS W/*

MOTOR PLATE & SHAFT ASSY.

MOTOR PLATE & SHAFT ASSY.

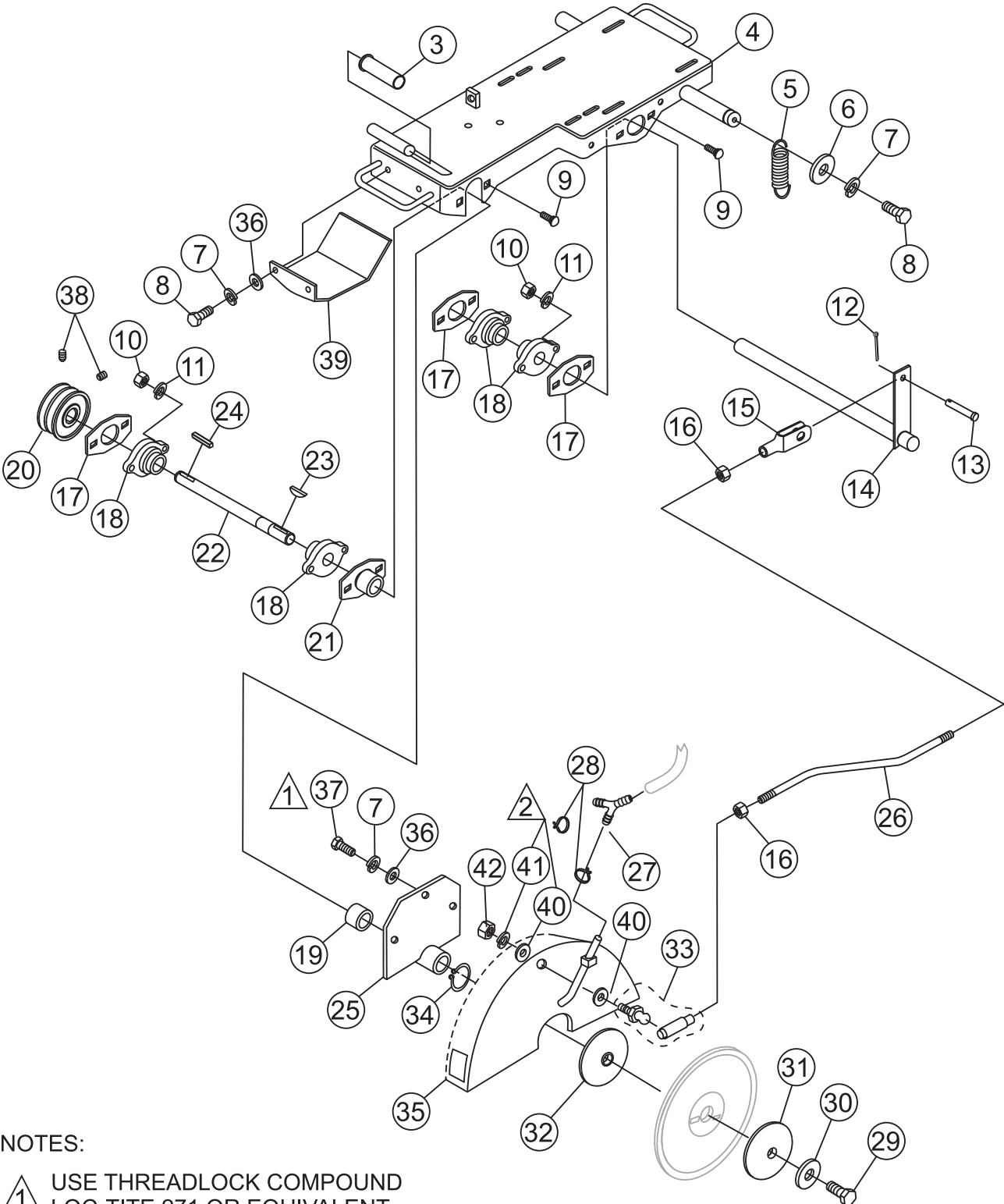

NOTES:

- 1 USE THREADLOCK COMPOUND LOC-TITE 271 OR EQUIVALENT.
- 2 ITEMS 40 AND 41 ARE NOT REQUIRED ON UNITS BUILT AFTER 06/03.

MOTOR PLATE & SHAFT ASSY.

MOTOR PLATE & SHAFT ASSY.

<u>NO.</u>	<u>PART NO.</u>	<u>PART NAME</u>	<u>QTY.</u>	<u>REMARKS</u>
3	26138-001	GRIP, HAND	1	
4	29707-351	PLATE, ELECTRIC MOTOR	1	
4	29708-351	PLATE, GASOLINE ENGINE	1	
5	23846-001	SPRING, 6 X 1.5 X 1.77 WIRE	1	
6	12391-004	WASHER, FLAT 1/4 AN970-4	1	
7	0181 B	WASHER, LOCK 1/4	3	
8	0131 A	SCREW, HHC 1/4 - 20 X 3/4	3	
9	17985-012	BOLT, CARRIAGE 3/8 - 16 X 1-1/2	8	
10	1456	NUT, HEX FINISH 3/8 - 16	8	
11	0166 A	WASHER, LOCK 3/8 MED	8	
12	0683	PIN, COTTER	1	
13	08326-005	PIN, CLEVIS 5/16 X 1	1	
14	29672-351	PIVOT BAR	1	
15	08327-009	YOKE END, 5/16 - 24 X 2.25	1	
16	07038-005	NUT, HEX JAM 5/16 - 24	3	
17	29678-001	SPACER	3	
18	29713-001	BEARING, FLANGE 1/8 ID	4	
19	29712-001	BUSHING	1	
20	29711-001	PULLEY, 2MA30X 7/8	1 ELECTRIC MODELS
20	28322-004	PULLEY, 2F3V30X 7/8	1 GAS MODELS
21	29680-351	PIVOT	1	
22	29697-001	SHAFT, SPINDLE BLADE	1	
23	07011-017	KEY, WOODRUFF #403	1	
24	0627	KEY, 3/16 X 1-1/4	1	
25	29683-351	MOUNT, BLADE GUARD	1	
26	29699-001	TIE ROD ELECTRIC MOTOR	1	
26	29715-001	TIE ROD GASOLINE ENGINE	1	
27	14233-002	Y-FITTING	1	
28	12694-001	CLAMP, HOSE	2	
29	8136	SCREW, HHC 1/2 - 20 X 1-1/2GR5	2	
30	5054 A	WASHER, LOCK 1/2 MED	1	
31	23832-001	FLANGE, OUTER	1	
32	29709-001	FLANGE, INNER	1	
33	23844-001	BALL JOINT - QD	1	
34	17510-003	SNAP RING	1	
35	23819-501	BLADE GUARD	1	
36	0948	WASHER, FLAT 1/4	5	
37	0730	SCREW, 1/4 - 20 X 1	3	
38	08696-008	SCREW, SET	2	
39	29727-351	GUARD, SPINDLE	1	
40	0300 B	WASHER, FLAT 5/16	2 NOT USED ON UNITS AFTER 06/03
41	0161 C	WASHER, LOCK 5/16	1 NOT USED ON UNITS AFTER 06/03
42	07038-005	NUT, HEX JAM 5/16-24 PLTD	1	

ENGINE HONDA 5.5 H.P.

ENGINE HONDA 5.5 H.P.

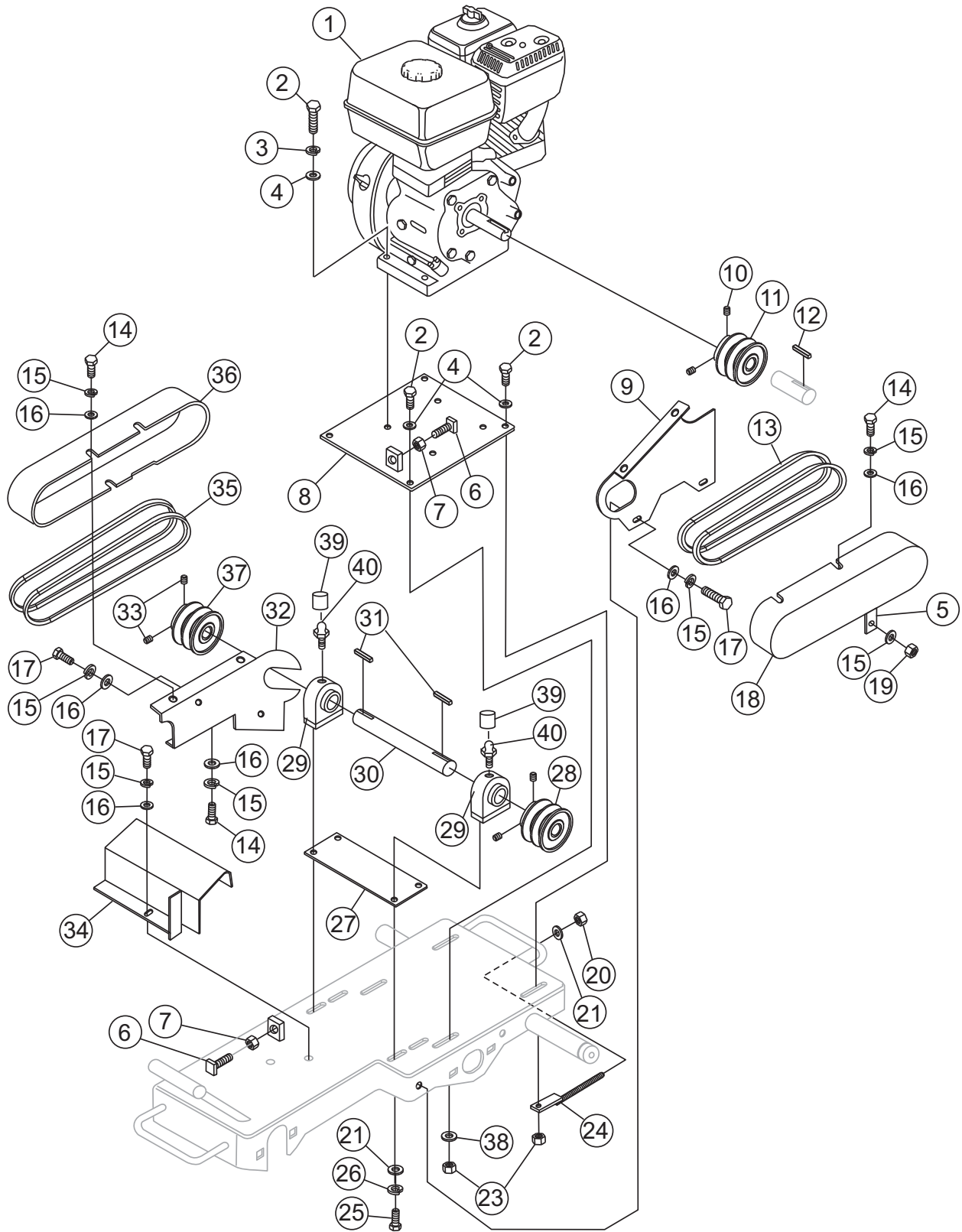

ENGINE HONDA 5.5 H.P.

ENGINE HONDA 5.5 H.P.

<u>NO.</u>	<u>PART NO.</u>	<u>PART NAME</u>	<u>QTY.</u>	<u>REMARKS</u>
1	22052-404	ENGINE, HONDA 5.5 H.P.	1	
2	2623	SCREW, HHC 5/16 - 18 X 1-1/4	8	
3	0161 C	WASHER, LOCK 5/16	4	
4	0300 B	WASHER, FLAT 5/16	4	
5	29724-001	BRACKET, MOUNTING	1	
6	27058-001	SCREW, SQHS 3/8 - 16 X 2	2	
7	1456	NUT, HEX 3/8 - 16	2	
8	28316-351	PLATE, ENGINE MOUNT	1	
9	29716-351	BRACKET, REAR BELT GUARD	1	
10	08696-006	SCREW, SHS 1/4 - 20 X 3/8	2	
11	28322-002	PULLEY, ENGINE	1	
12	0627	KEY, 3/16 X 1-1/4	1	
13	16779-012	BELT, 3VX250	2	
14	1579	SCREW, HHC 1/4 - 20 X 1/2	5	
15	0181 B	WASHER, LOCK 1/4	11	
16	0948	WASHER, FLAT 1/4	12	
17	0131 A	SCREW, HHC 1/4 - 20 X 3/4	5	
18	29648-501	GUARD, JACKSHAFT BELT	1	
19	10024	NUT, NYLOC 1/4 - 20	1	
20	10133	NUT, NYLOC 3/8 - 16	2	
21	10136	WASHER, FLAT 3/8	6	
23	5283	NUT, NYLOC 5/16 - 18	4	
24	23811-353	BELT TIGHTENER	2	
25	1023	SCREW, HHC 3/8 - 16 X 1-1/4	4	
26	0166 A	WASHER, LOCK 3/8	4	
27	29677-001	PLATE, JACKSHAFT SUPPORT	1	
28	28322-001	PULLEY, JACKSHAFT 2F3V30X1	1	
29	28321-001	BEARING, JACKSHAFT	2	
30	29666-001	JACKSHAFT	1	
31	10057-011	KEY, SQUARE 1/4 X 1-1/4	2	
32	29718-351	MT ASSY., BELT GUARD	1	
33	08697-006	SCREW, SHS 5/16 - 18 X 3/8	4	
34	29669-351	GUARD, JACKSHAFT	1	
35	16779-006	BELT, 3VX300	2	
36	29646-501	GUARD, BELT	1	UNITS WITHOUT PUMP
36	29647-001	GUARD, BELT	1	UNITS WITH PUMP
37	28322-003	PULLEY, JACKSHAFT 2F3V26X1	1	
38	19470	WASHER, FLAT 5/16	2	
39	1162 A	CAP, GREASE ZERK #2 YLW	2	
40	2621	ZERK, GREASE STR 1/4-28	2	

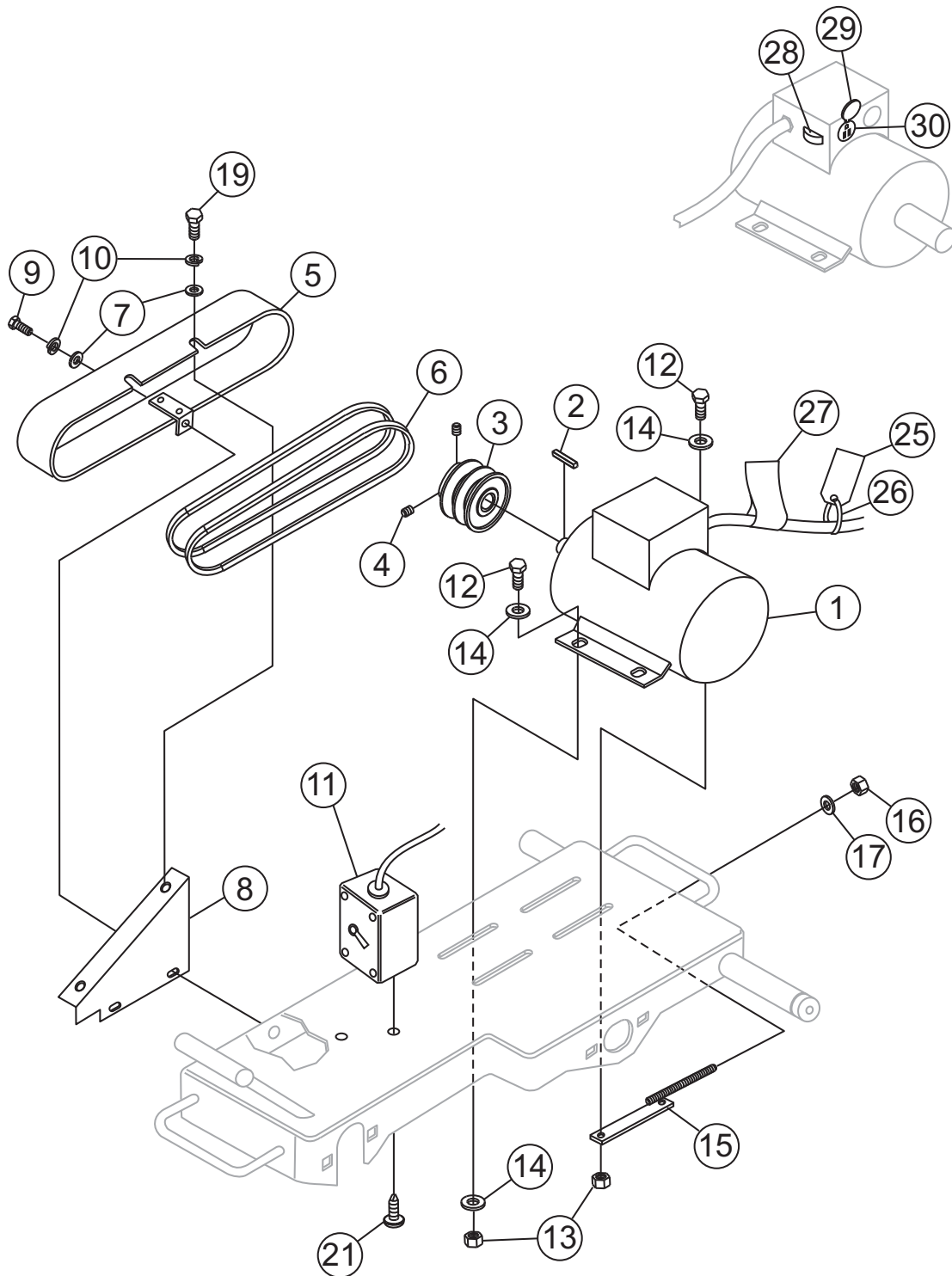

ELECTRIC MOTOR

ELECTRIC MOTOR

<u>NO.</u>	<u>PART NO.</u>	<u>PART NAME</u>	<u>QTY.</u>	<u>REMARKS</u>
1	23871-403	ELECTRIC MOTOR, 1-1/2 HP	1	
1	25140-402	ELECTRIC MOTOR, 2 HP	1	
2	0627	KEY, 3/16 X 1-1/4	2	
3	23863-001	PULLEY (MOTOR)	1	
4	08696-006	SCREW, SHS 1/4 - 20 X 3/8	2	
5	29053-501	BELT GUARD	1	
6	521003	BELT - AX-34	2	
7	0948	WASHER, FLAT 1/4	4	
8	29710-351	MOUNT, BELT GUARD	1	
9	0131 A	SCREW, HHC 1/4 - 20 x 3/4"	2	
10	0181 B	WASHER, LOCK 1/4	4	
11	24037-501	SWITCHBOX ASSEMBLY	1	
12	2623	SCREW, HHC 5/16 - 18 x 1-1/4"	4	
13	08233-005	NUT, LOCK 5/16 - 18 GRIPCO	4	
14	19470	WASHER, FLAT 5/16	8	
15	23811-353	BELT TIGHTENER	2	
16	10133	NUT, NYLOC 3/8 - 16	2	
17	10136	WASHER, FLAT 3/8	2	
19	1579	SCREW, HHC 1/4 - 20 x 1/2"	2	
21	23865-001	SCREW, SELF-TAP	2	
25	25139-001	LABEL, CORD SIZE	1	
26	1662	TIE, CABLE	1	
27	25215-001	DECAL, WARNING	1	

WATER PUMP ASSY. (GASOLINE ONLY)

WATER PUMP ASSY. (GASOLINE ONLY)

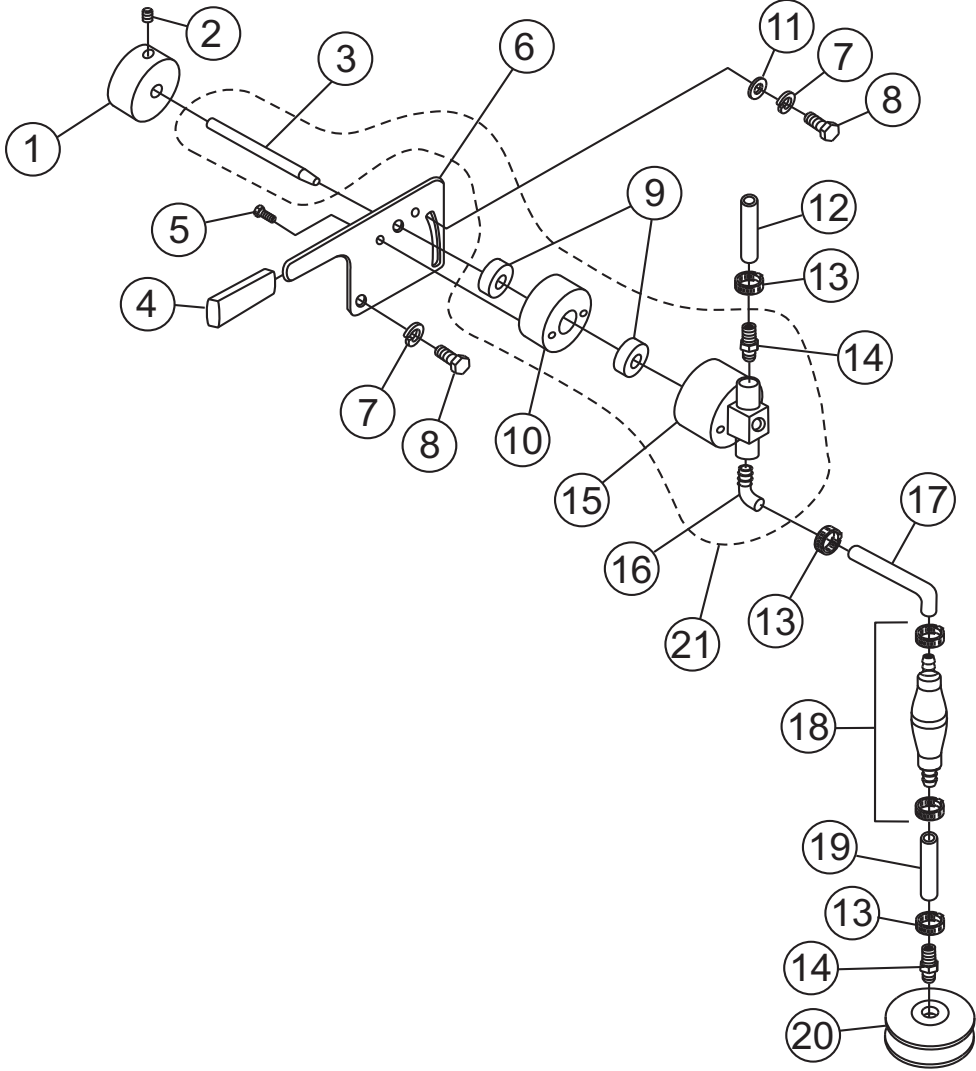

WATER PUMP ASSY. (GASOLINE ONLY)

WATER PUMP ASSY. (GASOLINE ONLY)

<u>NO.</u>	<u>PART NO.</u>	<u>PART NAME</u>	<u>QTY.</u>	<u>REMARKS</u>
1	28917-001	PULLEY, WATER PUMP 3"	1	
2	10138	SCREW, SHS 1/4 - 20 X 1/2	1	
3*	28910-001	PUMP SHAFT	1	
4	25799-001	HAND GRIP	1	
5	10120-010	SCREW, RHM 1/4 - 20 X 5/8	2	
6	28964-001	BRACKET, PUMP MOUNT	1	
7	0166 A	WASHER, LOCK 3/8	2	
8	0205	SCREW, HHCS 3/8 - 16 x 1"	2	
9*	09189-006	BEARING, BALL	2	
10*	28916-001	CAP, PUMP	1	
11	10136	WASHER, FLAT 3/8	1	
12	24892-011	HOSE, 3/8 X 10.5	1	
13	12696-004	CLAMP, HOSE	4	
14*	25874-001	FITTING, PLASTIC STR 6 BARB	2	
15*	25802-001	WATER PUMP	1	
16*	2925	FITTING, PLASTIC 90 6 BARB	1	
17	24892-012	HOSE, WATER 3/8 X 17	1	
18	25875-001	PRIMER BULB W/CLAMP	1	
19	24892-013	HOSE, WATER 3/8 X 6	1	
20	25685-001	STRAINER	1	
21	25807-502	PUMP ASSEMBLY	1	INCLUDES ITEMS W/*

SUPPORT STAND ASSY.

SUPPORT STAND ASSY. (Option)

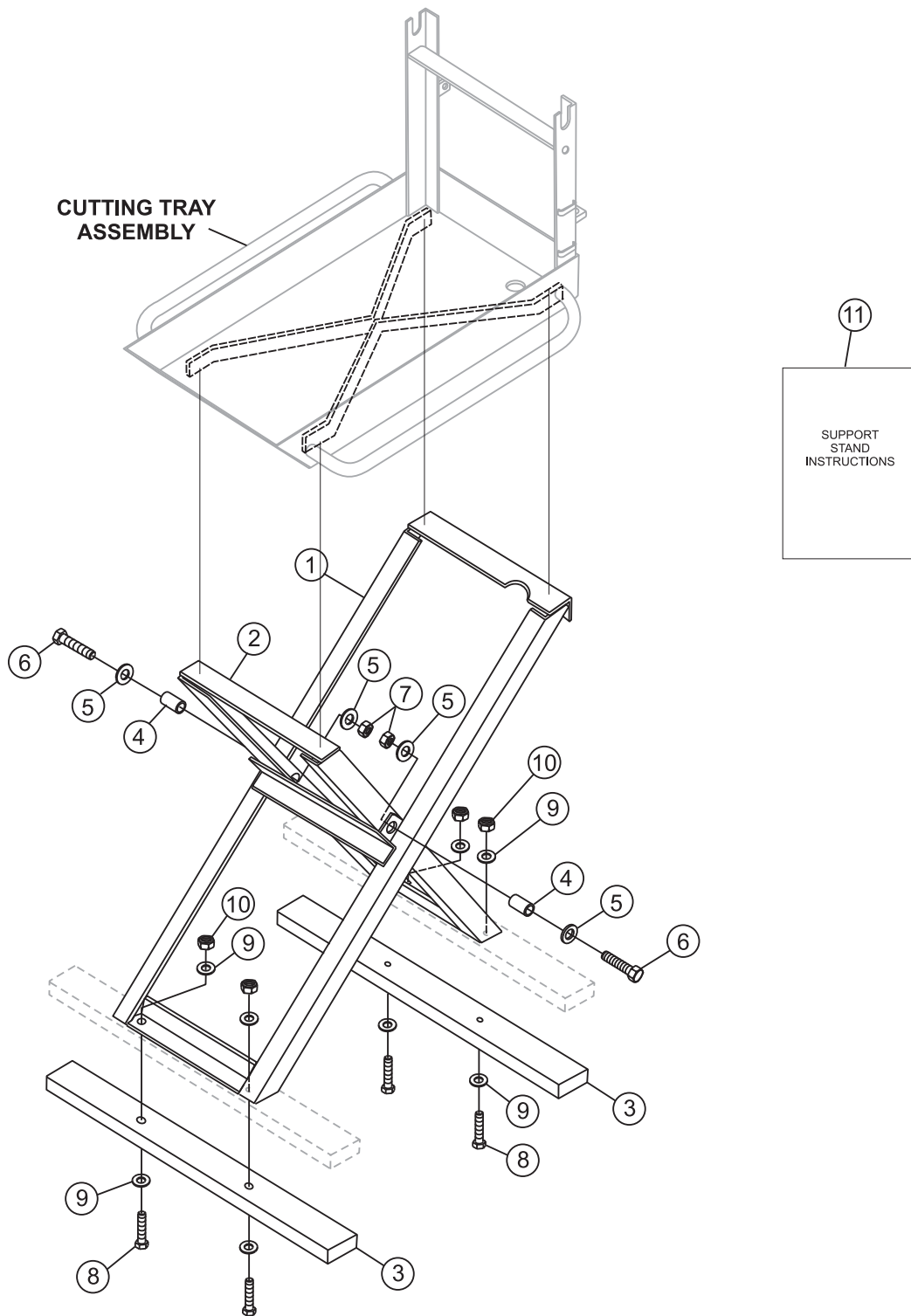

SUPPORT STAND ASSY.

SUPPORT STAND ASSY. (Option)

<u>NO.</u>	<u>PART NO.</u>	<u>PART NAME</u>	<u>QTY.</u>	<u>REMARKS</u>
1	23748-351	STAND ASSEMBLY OUTER	1	
2	23747-351	STAND ASSEMBLY INNER	1	
3	25396-001	PLATFORM STAND 2X4 TREX WOOD POLYMER	1	
4	26045-001	BUSHING	2	
5	07030-006	WASHER, FLAT 3/8"	4	
6	06501-010	SCREW, HHCS 3/8-16 X 1-1/4	2	
7	08233-006	LOCK NUT 3/8-16" GRIPCO	2	
8	06500-016	SCREW, HHCS 5/16-18 X2"	4	
9	07030-005	WASHER, FLAT 5/16"	8	
10	08233-005	LOCK NUT 5/16-18" GRIPCO	2	
11	25949	INSTRUCTIONS, SUPPORT STAND	1	

HONDA GX160K1QXC9 — AIR CLEANER ASSY.

AIR CLEANER (CYCLONE) ASSY.

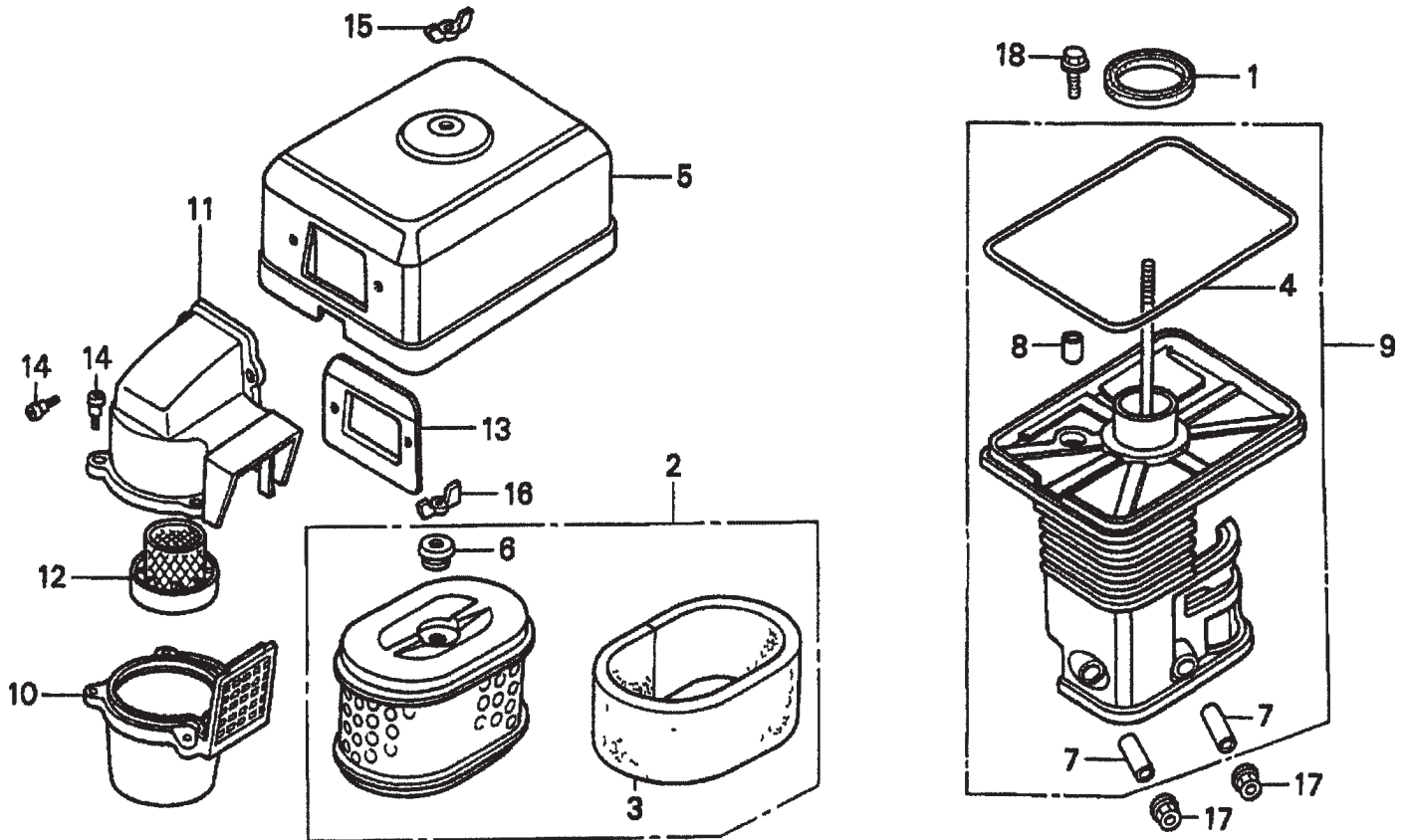

HONDA GX160K1QXC9 — AIR CLEANER ASSY.

AIR CLEANER (CYCLONE) ASSY.

<u>NO.</u>	<u>PART NO.</u>	<u>PART NAME</u>	<u>QTY.</u>	<u>REMARKS</u>
1	16271ZE1000	GASKET, ELBOW	1	
2	17210ZE1505	ELEMENT, AIR CLEANER (DUAL)	1	INCLUDES ITEMS W/*
3*	17218ZE1505	FILTER, OUTER	1	
4#	17219733010	GASKET, AIR CLEANER COVER	1	
5	17230ZE1841	COVER, AIR CLEANER (DUAL)	1	
6*	17232891000	GROMMET, AIR CLEANER	1	
7#	17238ZE7010	COLLAR, AIR CLEANER	2	
8#	17239733000	COLLAR B, AIR CLEANER	1	
9	17410ZE1840	ELBOW, AIR CLEANER	1	INCLUDES ITEMS W/#
10	17470ZE1841	CASE, PRE AIR CLEANER	1	
11	17475ZE1841	CAP, PRE AIR CLEANER	1	
12	17476ZE1841	GUIDE, PRE AIR CLEANER	1	
13	17478ZE1841	PLATE, PRE AIR CLEANER	1	
14	90300GB0900	BOLT, MUDGUARD	5	
15	90325044000	WINGNUT, TOOL BOX SETTING	1	
16	90325044000	WINGNUT, TOOL BOX SETTING	1	
17	9405006000	NUT, FLANGE (6MM)	5	
18	957010602000	BOLT, FLANGE (6X20)	1	

HONDA GX160K1QXC9 — CAMSHAFT ASSY.

CAMSHAFT ASSY.

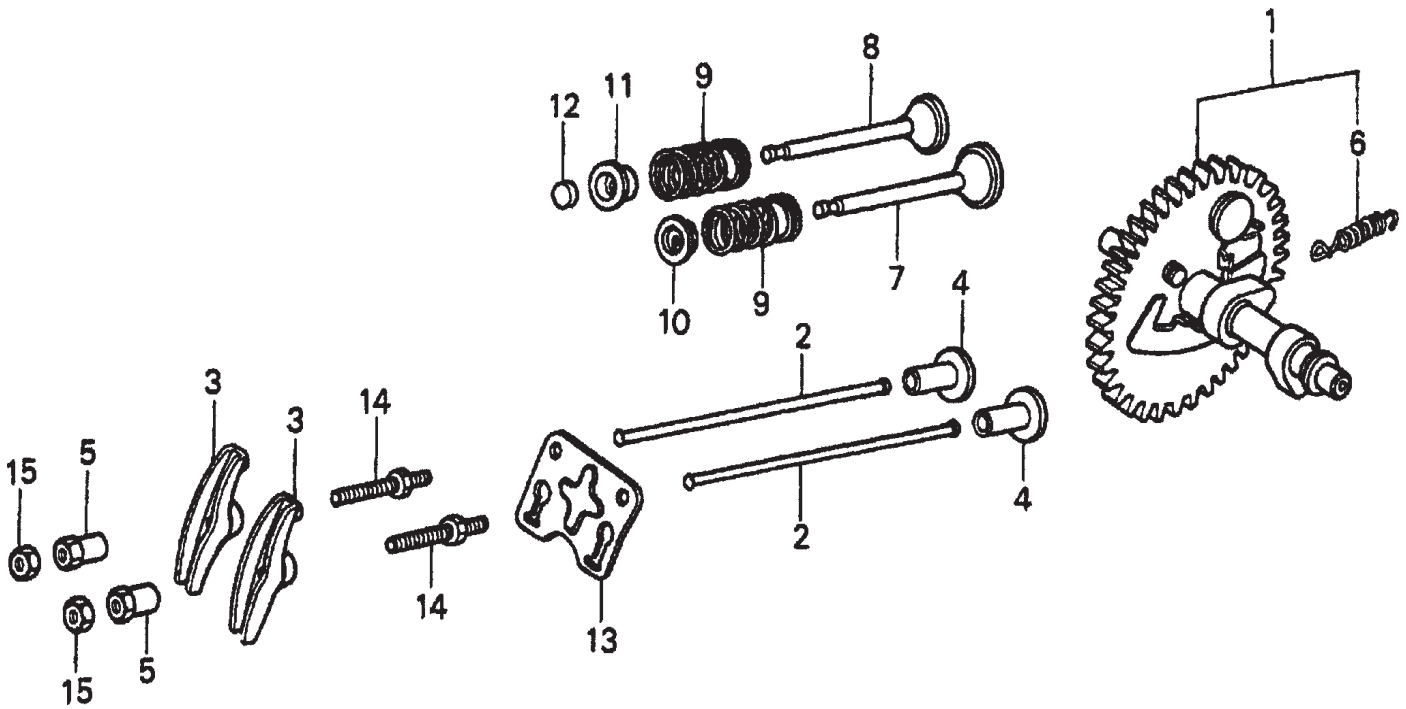

HONDA GX160K1QXC9 — CAMSHAFT ASSY.

CAMSHAFT ASSY.

<u>NO.</u>	<u>PART NO.</u>	<u>PART NAME</u>	<u>QTY.</u>	<u>REMARKS</u>
1	14100ZE1812	CAMSHAFT ASSEMBLY	1	INCLUDES ITEMS W/*
2	14410ZE1010	ROD, PUSH	2	
3	14431ZE1000	ARM, VALVE ROCKER	2	
4	14441ZE1010	LIFTER, VALVE	2	
5	14451ZE1013	PIVOT, ROCKER ARM	2	
6*	14568ZE1000	SPRING, WEIGHT RETURN	1	
7	14711ZF1000	VALVE, INTAKE	1	
8	14721ZF1000	VALVE, EXHAUST	1	
9	14751ZF1000	SPRING, VALVE	2	
10	14771ZE1000	RETAINER, INTAKE VALVE SPRING	1	
11	14773ZE1000	RETAINER, EXHAUST VALVE SPRING	1	
12	14781ZE1000	ROTATOR, VALVE	1	
13	14791ZE1010	PLATE, PUSH ROD GUIDE	1	
14	90012ZE0010	BOLT, PIVOT 8MM	2	
15	90206ZE1000	NUT, PIVOT ADJ.	2	

HONDA GX160K1QXC9 — CARBURETOR ASSY.

CARBURETOR ASSY.

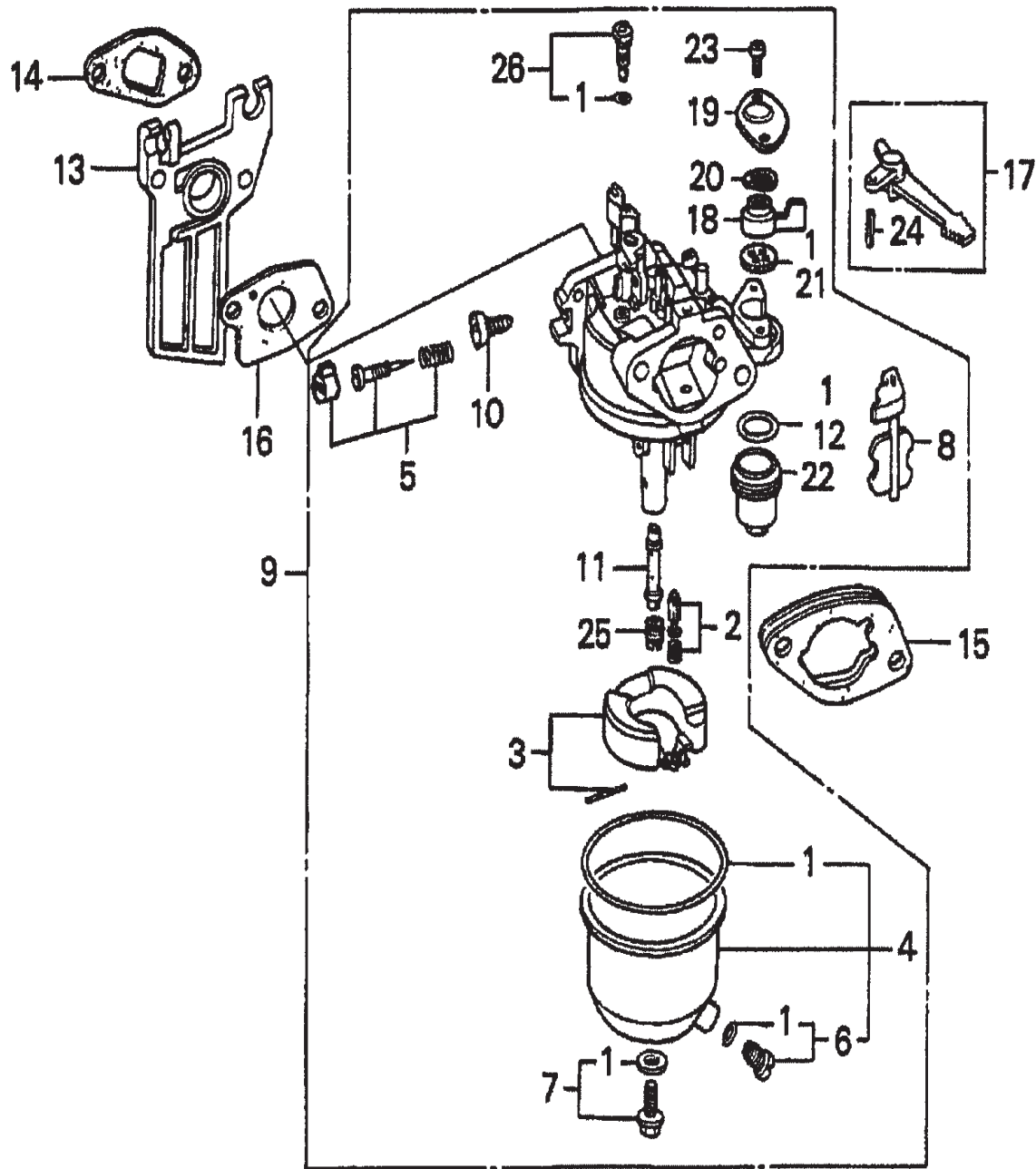

HONDA GX160K1QXC9 — CARBURETOR ASSY.

CARBURETOR ASSY.

<u>NO.</u>	<u>PART NO.</u>	<u>PART NAME</u>	<u>QTY.</u>	<u>REMARKS</u>
1*#%+	16010ZE1812	GASKET SET	1	
2*	16011ZE0005	VALVE SET, FLOAT	1	
3*	16013ZE0005	FLOAT SET	1	
4*	16015ZE0831	CHAMBER SET, FLOAT	1	
5*	16016ZH8W01	SCREW SET	1	
6	16024ZE1811	SCREW SET, DRAIN	1	INCLUDES ITEMS W/%
7	16028ZE0005	SCREW SET B	1	INCLUDES ITEMS W/#
8*	16044ZE0005	CHOKE SET	1	
9	16100ZH8V21	CARBURETOR ASSEMBLY, BE65G B..	1	INCLUDES ITEMS W/*
10*	16124ZE0005	SCREW, THROTTLE STOP	1	
11*	16166ZH8W00	NOZZLE, MAIN	1	
12*	16173001004	O- RING	1	
13	16211ZE1000	INSULATOR, CARBURETOR	1	
14	16212ZH8800	GASKET, INSULATOR	1	
15	16220ZE1020	SPACER, CARBURETOR	1	
16	16221ZH8801	GASKET, INSULATOR	1	
17	16610ZE1000	LEVER, CHOKE (STANDARD)	1	INCLUDES ITEMS W/>
18*	16953ZE1812	LEVER, VALVE	1	
19*	16954ZE1812	PLATE, LEVER SETTING	1	
20*	16956ZE1811	SPRING, VALVE LEVER	1	
21	16957ZE1812	GASKET, VALVE	1	
22*	16967ZE0811	CUP, FUEL STRAINER	1	
23*	93500030060H	SCREW, PAN 3X6	2	
24>	9430520122	PIN, SPRING 2X12	1	
25*	99101ZH80680	JET, MAIN #68	1	
25	99101ZH70620	JET, MAIN #62 (OPTIONAL)	1	
25	99101ZH80620	JET, MAIN #62 (OPTIONAL)	1	
25	99101ZH80650	JET, MAIN #65 (OPTIONAL)	1	
26*	99204ZE20400	JET SET, PILOT #40	1	INCLUDES ITEMS W/+

HONDA GX160K1QXC9 — CONTROL ASSY.

CONTROL ASSY.

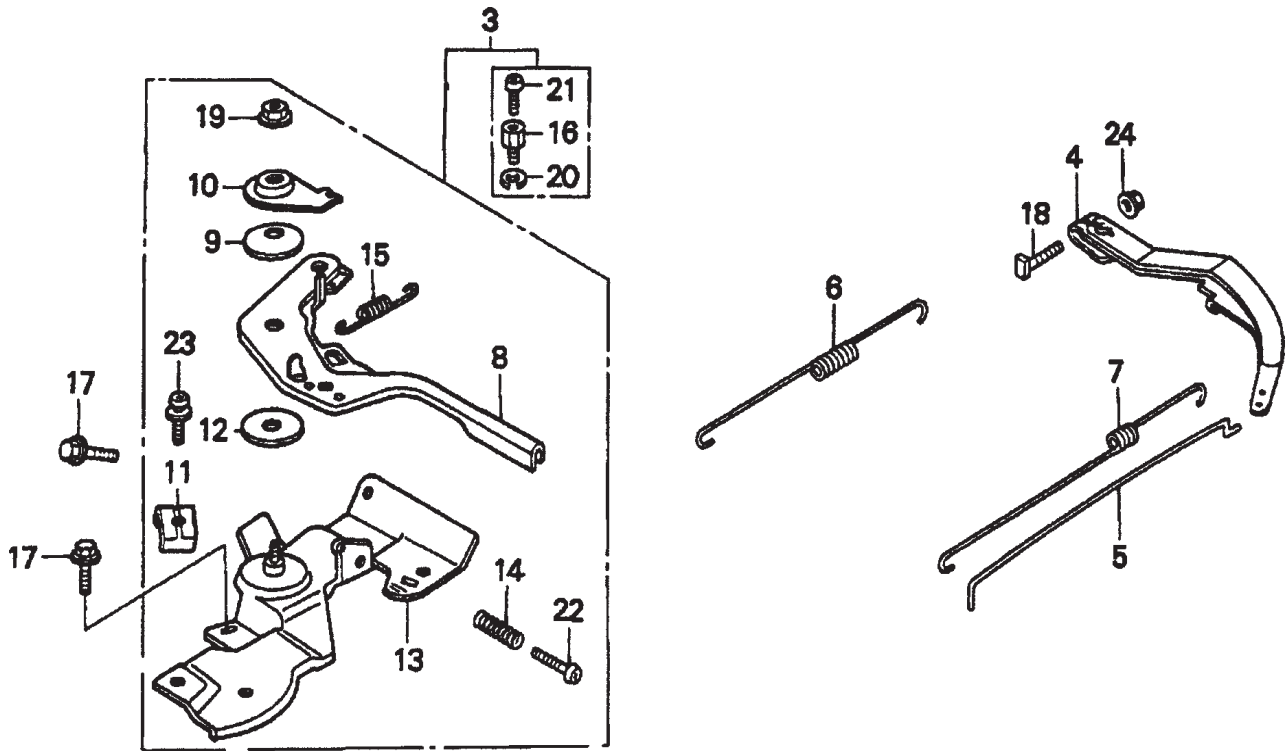

HONDA GX160K1QXC9 — CONTROL ASSY.

CONTROL ASSY.

<u>NO.</u>	<u>PART NO.</u>	<u>PART NAME</u>	<u>QTY.</u>	<u>REMARKS</u>
3	16500ZH8853	CONTROL ASSEMBLY, CYCLONE.....	1	INCLUDES ITEMS W/*
4	16551ZE0010	ARM, GOVERNOR	1	
5	16555ZE1000	ROD, GOVERNOR	1	
6	16561ZE1020	SPRING, GOVERNOR	1	
7	16562ZE1020	SPRING, THROTTLE RETURN	1	
8*	16571ZH8020	LEVER, CONTROL	1	
9*	16574ZE1000	SPRING, LEVER	1	
10*	16575ZH8000	WASHER, CONTROL LEVER	1	
11*	16576891000	HOLDER, CABLE	1	
12*	16578ZE1000	SPACER, CONTROL LEVER	1	
13*	16580ZH8853	BASE, CONTROL (CYCLONE)	1	
14*	16584883300	SPRING, CONTROL ADJUSTING	1	
15*	16592ZE1810	SPRING, CABLE RETURN	1	
16*	16594883010	HOLDER, WIRE	1	
17	90013883000	BOLT, FLANGE 6X12 (CT200)	2	
18	90015ZE5010	BOLT, GOVERNOR ARM	1	
19*	90114SA0000	NUT, SELF- LOCK 6MM	1	
20*	90605230000	CIRCLIP 5MM	1	
21*	93500040060H	SCREW, PAN 4X6	1	
22*	93500050250H	SCREW, PAN 5X25	1	
23*	93500050160A	SCREW, PAN 5X16	1	
24	9405006000	NUT, FLANGE 6MM	1	

HONDA GX160K1QXC9 — CRANKCASE COVER ASSY.

CRANKCASE COVER ASSY.

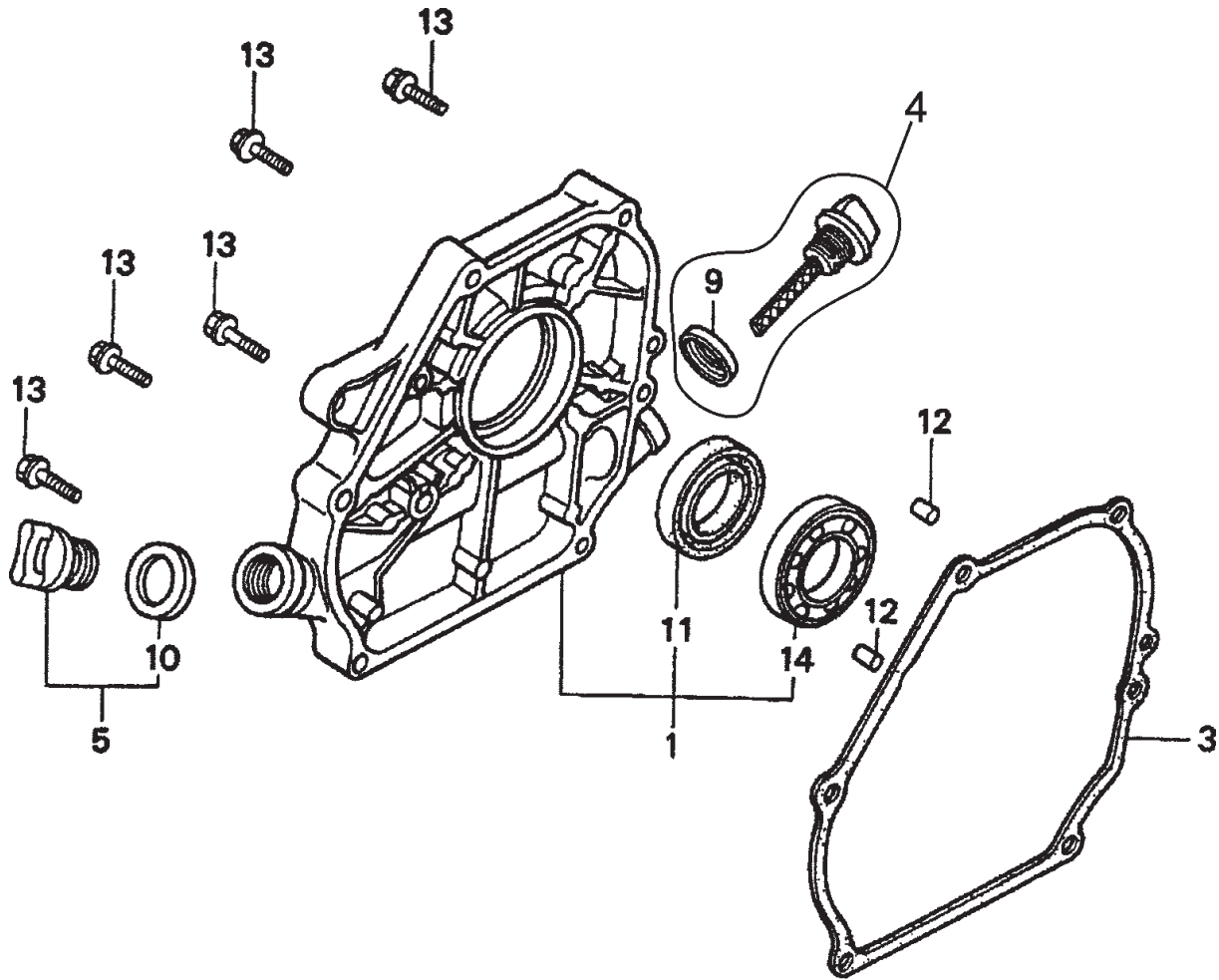

HONDA GX160K1QXC9 — CRANKCASE COVER ASSY.

CRANKCASE COVER ASSY.

<u>NO.</u>	<u>PART NO.</u>	<u>PART NAME</u>	<u>QTY.</u>	<u>REMARKS</u>
1	11300ZE1641	COVER ASSY., CRANKCASE U- TYPE.....	1.....	INCLUDES ITEMS W/*
3	11381ZH8801	GASKET, CASE COVER (NON-ASBESTOS)	1	
4	15600ZE1003	CAP ASSEMBLY, OIL FILLER.....	1.....	INCLUDES ITEMS W/#
5	15600ZG4003	CAP ASSEMBLY, OIL FILLER.....	1.....	INCLUDES ITEMS W/%
9#	15625ZE1003	GASKET, OIL FILLER CAP	1	
10%	15625ZE1003	GASKET, OIL FILLER CAP	1	
11*	91202883005	OIL SEAL 25X41X6	1	
12	9430108140	PIN A, DOWEL 8X14	2	
13	957010803200	BOLT, FLANGE 8X32	6	
14*	961006205000	BEARING, RADIAL BALL 6205	1	

HONDA GX160K1QXC9 — CRANKSHAFT ASSY.

CRANKSHAFT ASSY.

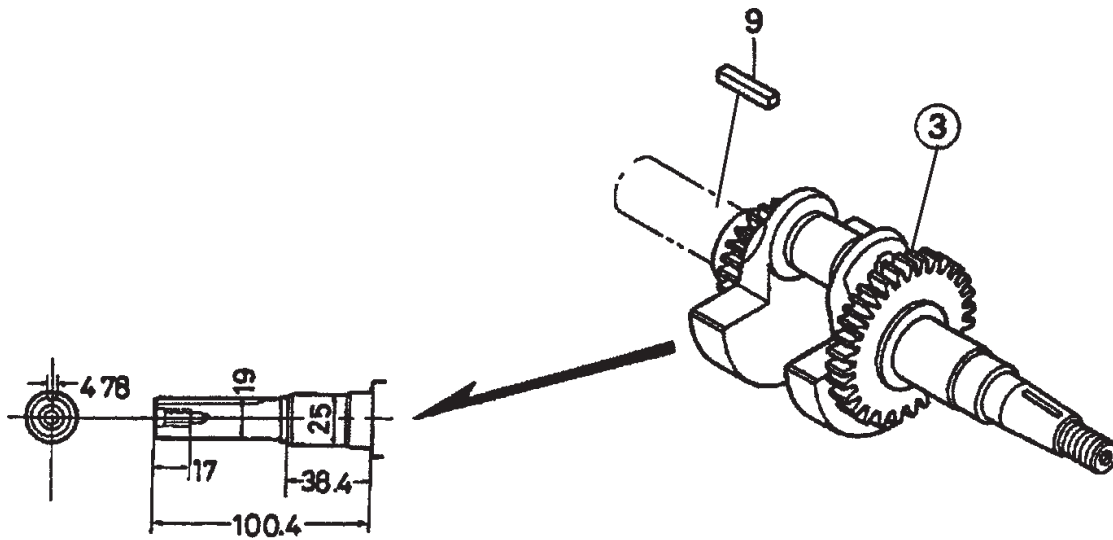

HONDA GX160K1QXC9 — CRANKSHAFT ASSY.

CRANKSHAFT ASSY.

<u>NO.</u>	<u>PART NO.</u>	<u>PART NAME</u>	<u>QTY.</u>	<u>REMARKS</u>
3	13310ZE1601	CRANKSHAFT (Q-TYPE)	1	
9	90745ZE1600	KEY 4.78X4.78X38	1	

HONDA GX160K1QXC9 — CYLINDER BARREL ASSY.

CYLINDER BARREL ASSY.

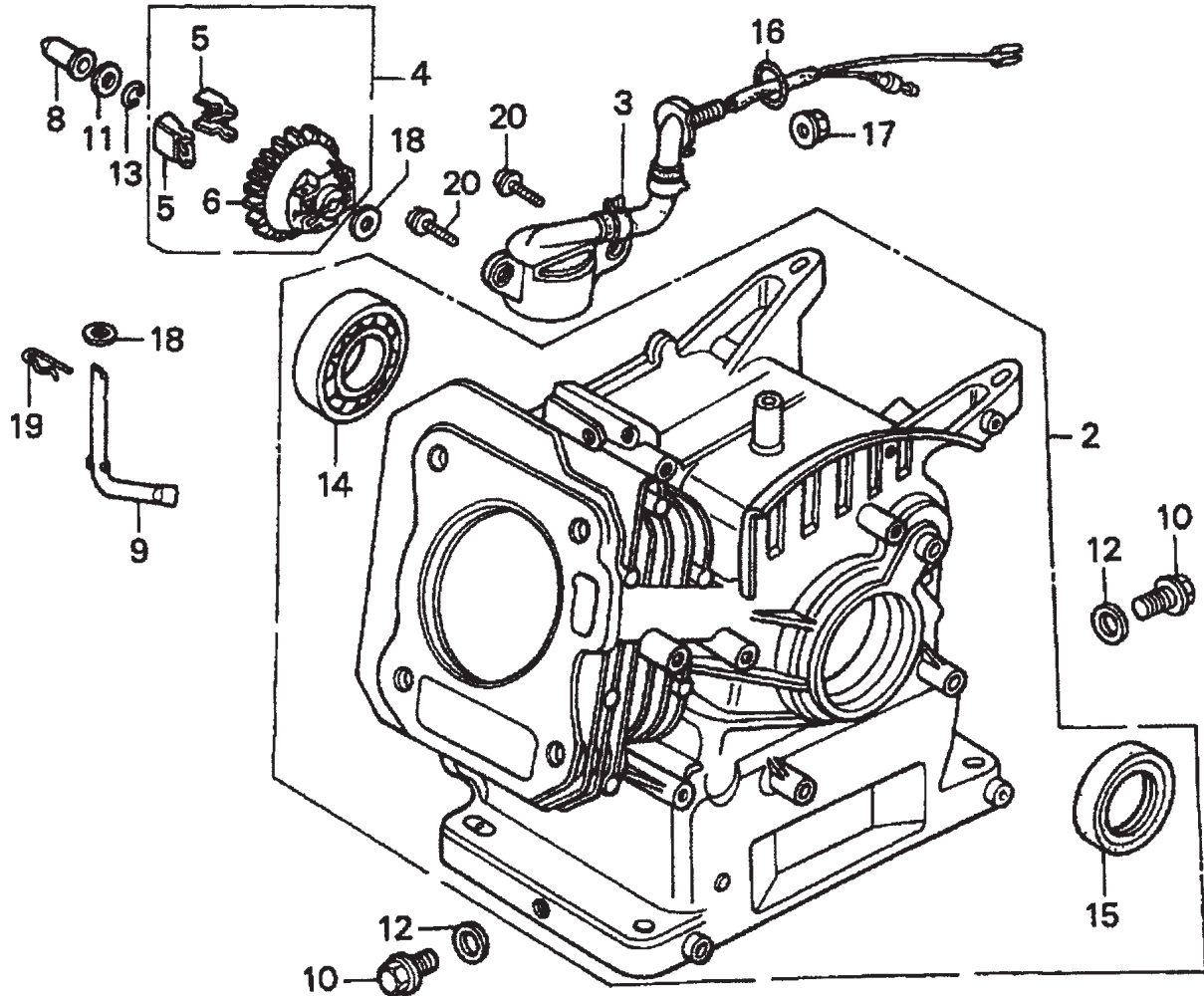

HONDA GX160K1QXC9 — CYLINDER BARREL ASSY.

CYLINDER BARREL ASSY.

<u>NO.</u>	<u>PART NO.</u>	<u>PART NAME</u>	<u>QTY.</u>	<u>REMARKS</u>
2	12000ZH8811	CYLINDER ASSEMBLY , OIL ALERT	1	INCLUDES ITEMS W/*
3	15510ZE1033	SWITCH ASSEMBLY, OIL LEVEL	1	
4	16510ZE1000	GOVERNOR ASSEMBLY	1	INCLUDES ITEMS W/#
5#	16511ZE1000	WEIGHT, GOVERNOR	2	
6#	16512ZE1000	HOLDER, GOVERNOR WEIGHT	1	
8	16531ZE1000	SLIDER, GOVERNOR	1	
9	16541ZE1000	SHAFT, GOVERNOR ARM	1	
10	90131ZE1000	BOLT, DRAIN PLUG	2	
11	90451ZE1000	WASHER, THRUST 6MM	1	
12	90601ZE1000	WASHER DRAIN PLUG 10.2MM	2	
13	90602ZE1000	CLIP, GOVERNOR HOLDER	1	
14*	91001ZF1003	BEARING, RADIAL BALL 6205	1	
15*	91202883005	OIL SEAL 25X41X6	1	
16	91353671003	O- RING 13.5X1.5 (ARAI)	1	
17	9405010000	NUT, FLANGE 10MM	1	
18	9410106800	WASHER, PLAIN 6MM	2	
19	9425108000	PIN, LOCK 8MM	1	
20	957010601200	BOLT, FLANGE 6X12	2	

HONDA GX160K1QXC9 — CYLINDER HEAD ASSY.

CYLINDER HEAD ASSY.

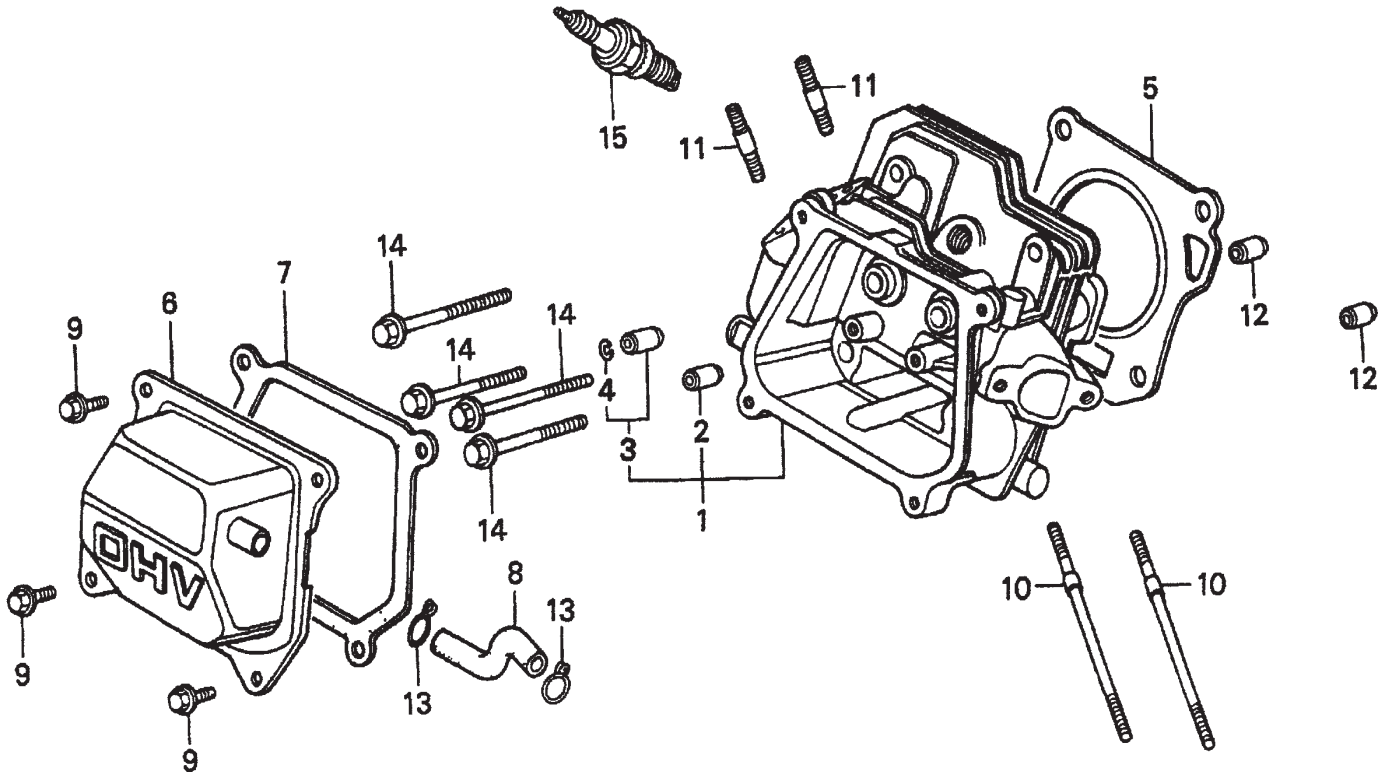

HONDA GX160K1QXC9 — CYLINDER HEAD ASSY.

CYLINDER HEAD ASSY.

<u>NO.</u>	<u>PART NO.</u>	<u>PART NAME</u>	<u>QTY.</u>	<u>REMARKS</u>
1	12210ZH8000	CYLINDER HEAD	1	INCLUDES ITEMS W/*
2*	12204ZE1306	GUIDE, VALVE OS (OPTIONAL)	1	
3*	12205ZE1315	GUIDE, EXHAUST VALVE OS (OPT.)	1	INCLUDES ITEMS W/#
4#	12216ZE5300	CLIP, VALVE GUIDE	1	
5	12251ZF1800	GASKET, CYLINDER HEAD	1	
6	12310ZE1841	COVER, HEAD	1	
7	12391ZE1000	GASKET, CYLINDER HEAD COVER	1	
8	15721ZE1840	TUBE, BREATHER	1	
9	90013883000	BOLT, FLANGE 6X12 (CT200)	4	
10	90043ZE1020	BOLT, STUD 6X109	2	
11	90047ZE1000	BOLT, STUD 8X32	2	
12	9430110160	PIN A, DOWEL 10X16	2	
13	9500280000	CLIP, TUBE C12	2	
14	957230806000	BOLT, FLANGE 8X60	4	
15	9807956846	SPARK PLUG BPR6ES (NGK)	1	

HONDA GX160K1QXC9 — FAN COVER ASSY.

FAN COVER ASSY.

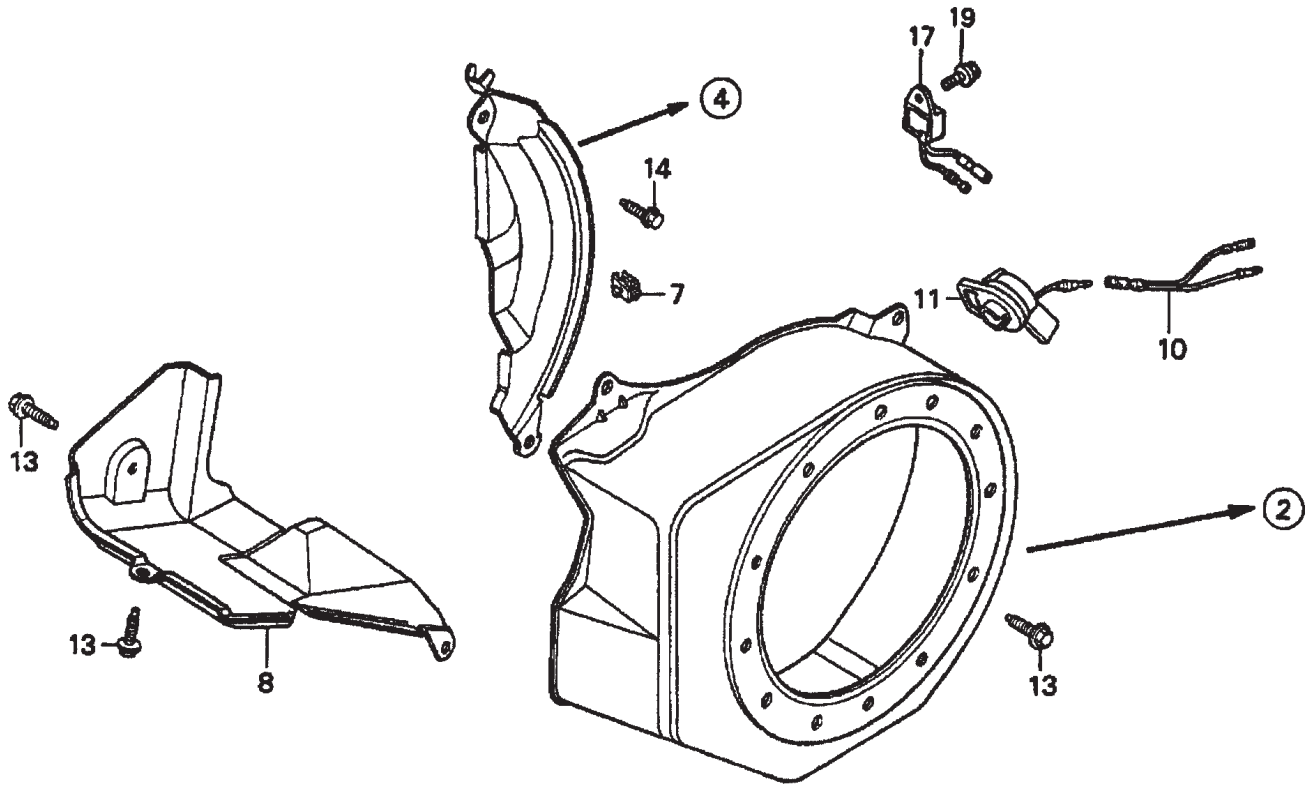

HONDA GX160K1QXC9 — FAN COVER ASSY.

FAN COVER ASSY.

<u>NO.</u>	<u>PART NO.</u>	<u>PART NAME</u>	<u>QTY.</u>	<u>REMARKS</u>
2	19610ZE1000ZA	COVER, FAN *R8* BRIGHT RED	1	
4	19611ZH8810	PLATE, SIDE (OIL ALERT)	1	
7	90601ZH7013	CLIP, HARNESS	1	
8	19630ZH8000	SHROUD	1	
10	32197ZH8003	SUB- HARNESS	1	
11	36100ZE1015	SWITCH ASSEMBLY, ENGINE STOP	1	
11	36100ZH7003	SWITCH ASSEMBLY, ENGINE STOP	1	
13	90013883000	BOLT, FLANGE 6X12 (CT200)	6	
14	90022888010	BOLT, FLANGE 6X20 (CT200)	1	
17	34150ZH7003	ALERT UNIT, OIL	1	
19	957010600800	BOLT, FLANGE 6X8	1	

HONDA GX160K1QXC9 — FLYWHEEL ASSY.

FLYWHEEL ASSY.

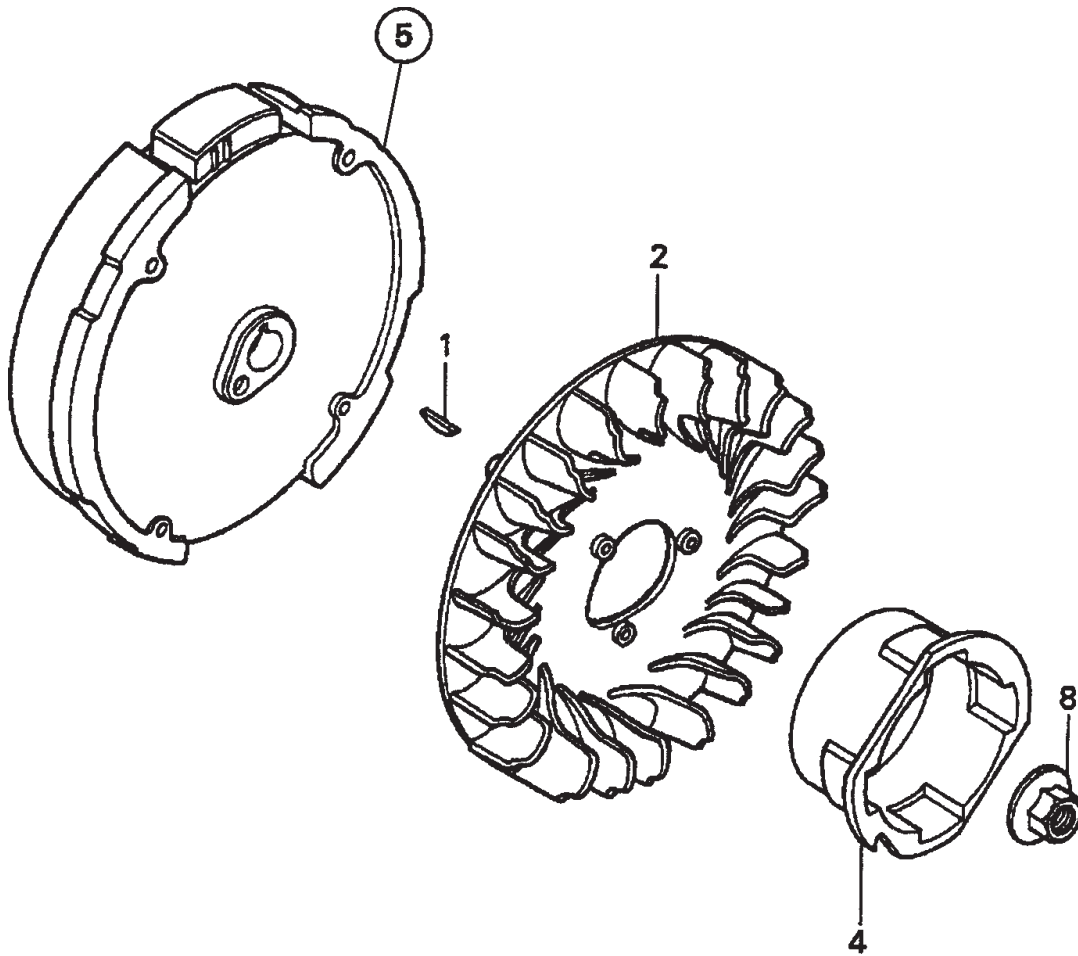

HONDA GX160K1QXC9 — FLYWHEEL ASSY.

FLYWHEEL ASSY.

<u>NO.</u>	<u>PART NO.</u>	<u>PART NAME</u>	<u>QTY.</u>	<u>REMARKS</u>
1	13331357000	KEY, SPECIAL WOODRUFF 25X18	1	
2	19511ZE1000	FAN, COOLING	1	
4	28451ZH8003	PULLEY, STARTER	1	
5	31100ZE1010	FLYWHEEL	1	
5	31100ZE1810	FLYWHEEL, LAMP	1	
8	90201878003	NUT, SPECIAL 14MM	1	

HONDA GX160K1QXC9 — FUEL TANK ASSY.

FUEL TANK ASSY.

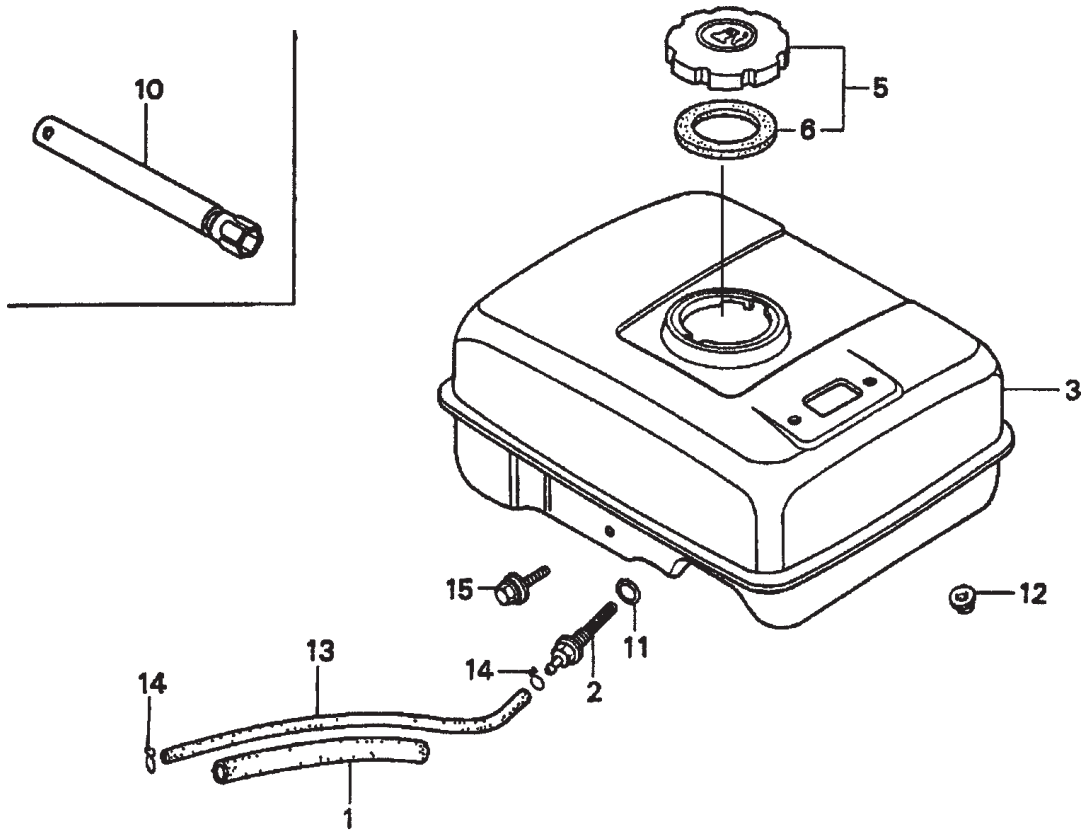

HONDA GX160K1QXC9 — FUEL TANK ASSY.

FUEL TANK ASSY.

<u>NO.</u>	<u>PART NO.</u>	<u>PART NAME</u>	<u>QTY.</u>	<u>REMARKS</u>
1	16854ZH8000	RUBBER, SUPPORTER 107MM	1	
2	16955ZE1000	JOINT, FUEL TANK	1	
3	17510ZE1020ZA	TANK, FUEL *NH31* MCKINLEY WHITE	1	
5	17620ZH7023	CAP, FUEL FILLER	1	
6	17631ZH7003	GASKET, FUEL FILLER CAP	1	
10	89218ZE1000	WRENCH, SPARK PLUG	1	
11	91353671003	O-RING 13.5X1.5 (ARAI)	1	
12	9405006000	NUT, FLANGE 6MM	2	
13	950014500360M	BULK HOSE, FUEL 4.5X3000 (4.5X140)	1	
14	9500202080	CLIP, TUBE B8	2	
15	957010602500	BOLT, FLANGE 6X25	1	

HONDA GX160K1QXC9 — IGNITION COIL ASSY.

IGNITION COIL ASSY.

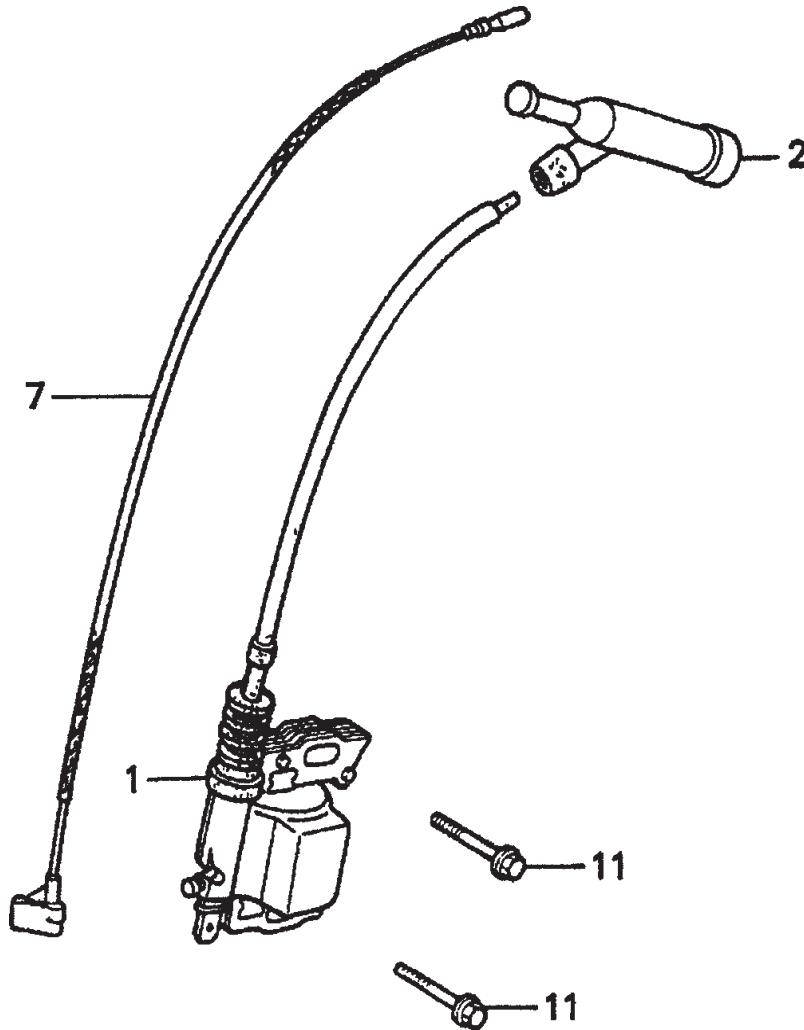

HONDA GX160K1QXC9 — IGNITION COIL ASSY.

IGNITION COIL ASSY.

<u>NO.</u>	<u>PART NO.</u>	<u>PART NAME</u>	<u>QTY.</u>	<u>REMARKS</u>
1	30500ZE1033	COIL ASSEMBLY, IGNITION	1	
2	30700ZE1013	CAP ASSEMBLY, NOISE SUPPRESSOR	1	
7	36101ZE1010	WIRE, STOP SWITCH 370MM	1	
11	90121952000	BOLT, FLANGE 6X25	2	

HONDA GX160K1QXC9 — MUFFLER ASSY.

MUFFLER ASSY.

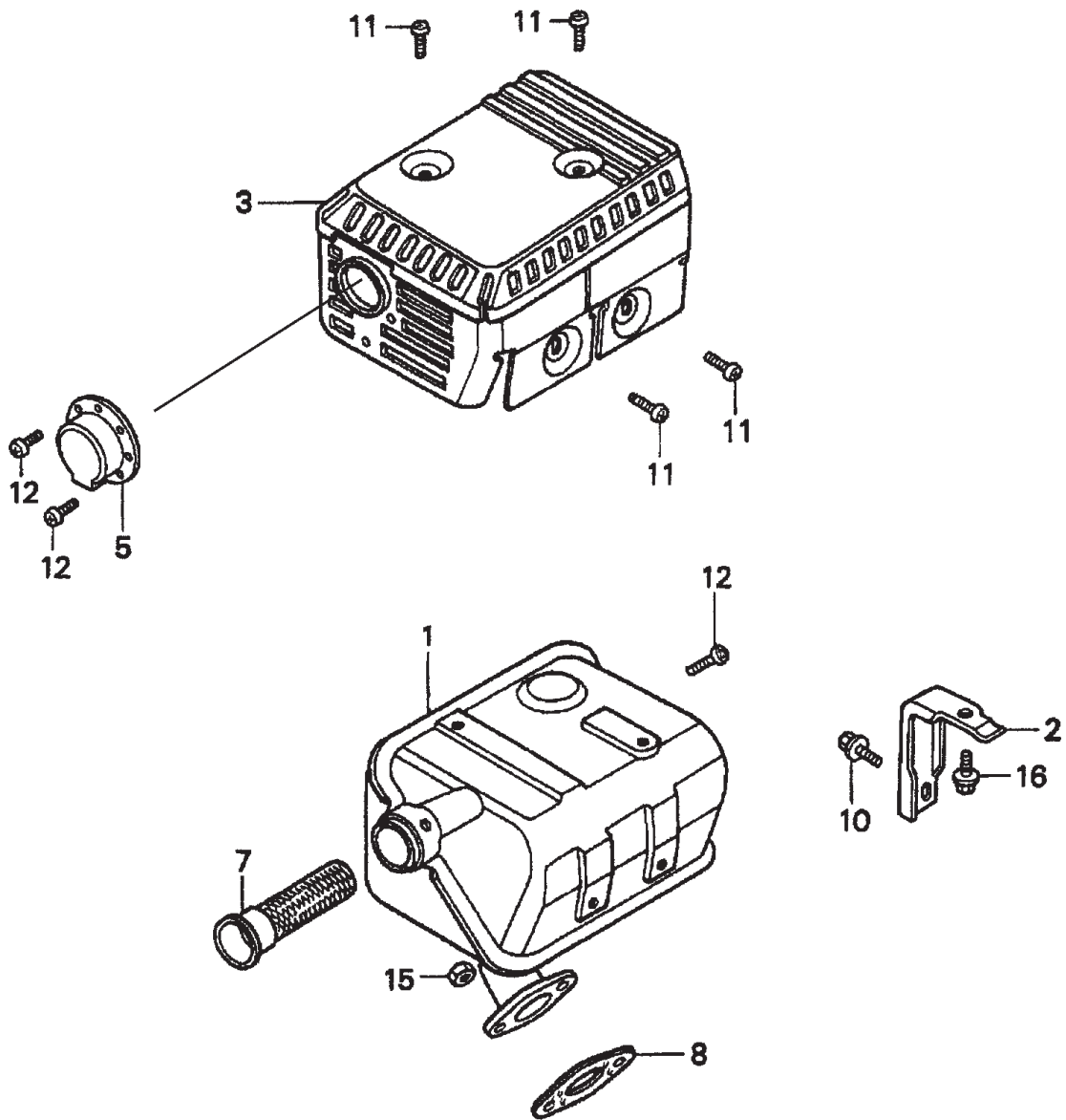

HONDA GX160K1QXC9 — MUFFLER ASSY.

MUFFLER ASSY.

<u>NO.</u>	<u>PART NO.</u>	<u>PART NAME</u>	<u>QTY.</u>	<u>REMARKS</u>
1	18310ZE1821	MUFFLER, SILENT	1	
2	18315ZE1000	STAY, MUFFLER	1	
3	18320ZF1H51	PROTECTOR, MUFFLER	1	
5	18331883810	CAP, MUFFLER	1	
7	18355ZE1810	ARRESTER, SPARK (SILENT)	1	
8	18381ZH8800	GASKET, MUFFLER	1	
10	90016ZE1000	BOLT, FLANGE 6X13	1	
11	90050ZE1000	SCREW, TAPPING 5X8	4	
12	90055ZE1000	SCREW, TAPPING 4X6	3	
15	94001080000S	NUT, HEX. 8MM	2	
16	957010601200	BOLT, FLANGE 6X12	1	

HONDA GX160K1QXC9 — PISTON AND RINGS ASSY.

PISTON AND RINGS ASSY.

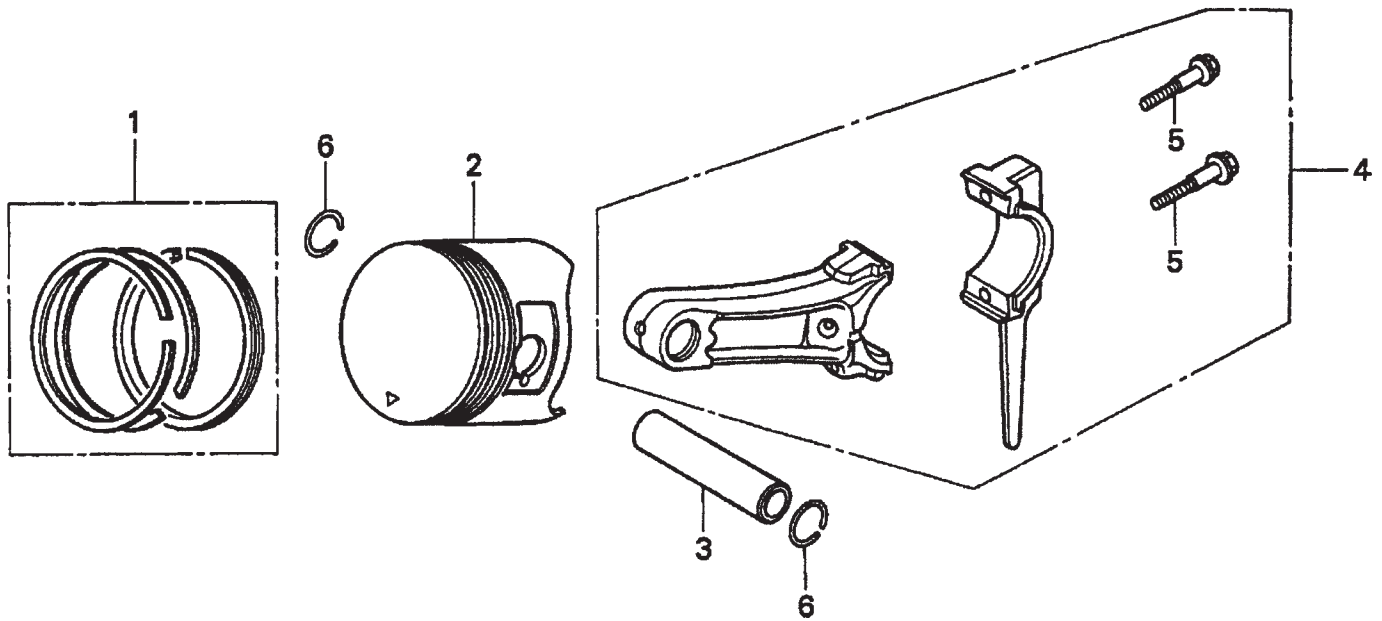

HONDA GX160K1QXC9 — PISTON AND RINGS ASSY.

PISTON AND RINGS ASSY.

<u>NO.</u>	<u>PART NO.</u>	<u>PART NAME</u>	<u>QTY.</u>	<u>REMARKS</u>
1	13010ZF1023	RING SET, PISTON (STANDARD)	1	
1	13010ZH8941	RING SET, PISTON (STANDARD)	1	
1	13011ZF1023	RING SET, PISTON (OS 0.25) (OPTIONAL)	1	
1	13011ZH8941	RING SET, PISTON (OS 0.25) (OPTIONAL)	1	
1	13012ZF1023	RING SET, PISTON (OS 0.50) (OPTIONAL)	1	
1	13012ZH8941	RING SET, PISTON (OS 0.50) (OPTIONAL)	1	
1	13013ZF1023	RING SET, PISTON (0.75) (OPTIONAL)	1	
1	13013ZH8941	RING SET, PISTON (0.75) (OPTIONAL)	1	
2	13101ZH8000	PISTON, STANDARD	1	
2	13102ZH8000	PISTON , OS 0.25 (OPTIONAL)	1	
2	13103ZH8000	PISTON, OS 0.50 (OPTIONAL)	1	
2	13104ZH8000	PISTON, 0.75 (OPTIONAL)	1	
3	13111ZE1000	PIN, PISTON	1	
4	13200ZE1010	ROD ASSEMBLY, CONNECTING	1	INCLUDES ITEMS W/*
5*	90001ZE1000	BOLT, CONNECTING ROD	2	
6	90551ZE1000	CLIP, PISTON PIN 18MM	2	

HONDA GX160K1QXC9 — RECOIL STARTER ASSY.

RECOIL STARTER ASSY.

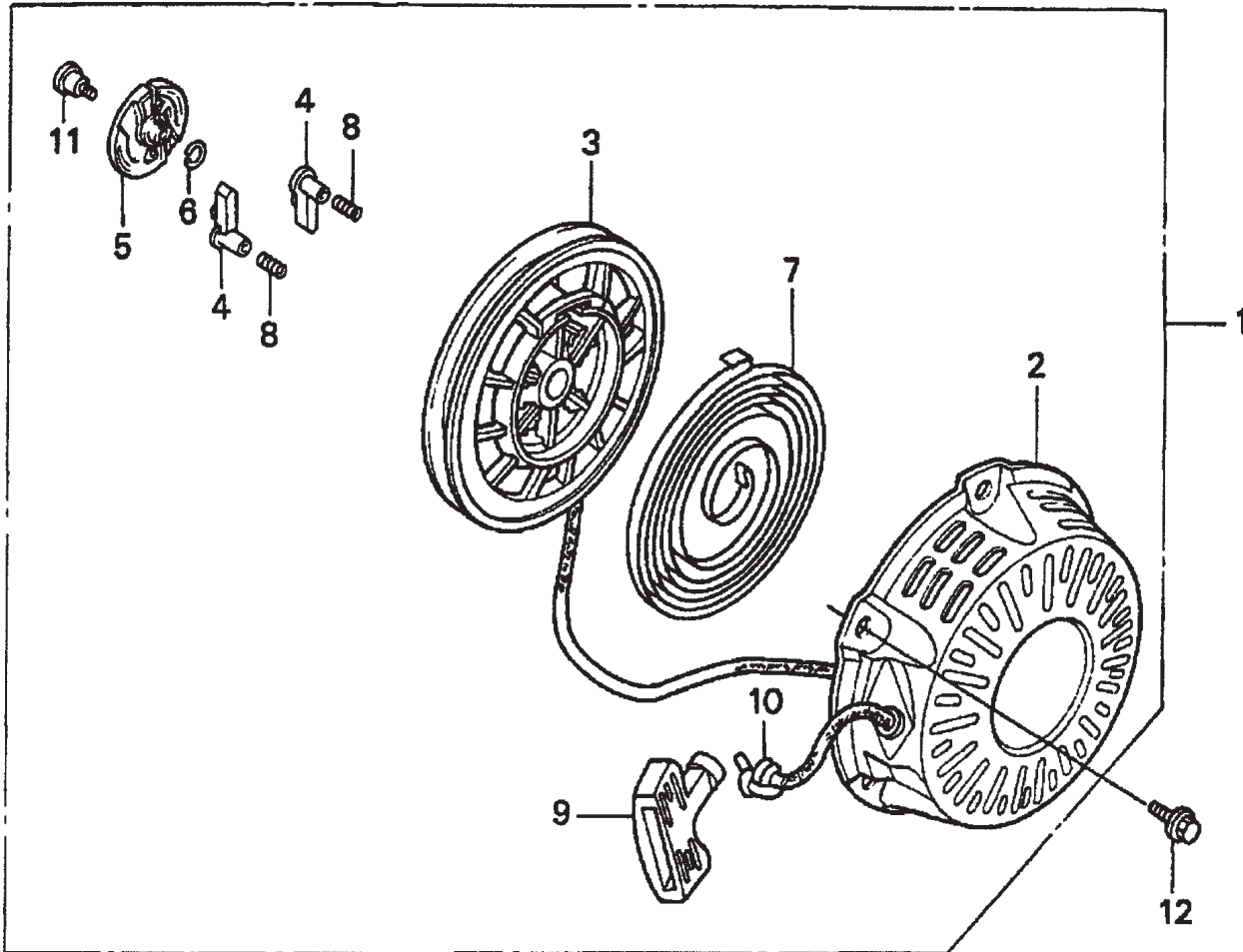

HONDA GX160K1QXC9 — RECOIL STARTER ASSY.

RECOIL STARTER ASSY.

<u>NO.</u>	<u>PART NO.</u>	<u>PART NAME</u>	<u>QTY.</u>	<u>REMARKS</u>
1	28400ZH8013ZA	STARTER ASSY., RECOIL *R8*BRIGHT RED	1	INCLUDES ITEMS W/*
2*	28410ZH8003ZA	CASE, RECOIL STARTER *R8* BRIGHT RED	1	
3*	28420ZH8013	REEL, RECOIL STARTER	1	
4*	28422ZH8013	RATCHET, STARTER	2	
5*	28433ZH8003	GUIDE, RATCHET	1	
6*	28441ZH8003	SPRING, FRICTION	1	
7*	28442ZH8003	SPRING, RECOIL STARTER	1	
8*	28443ZH8003	SPRING, RETURN	2	
9*	28461ZH8003	KNOB, RECOIL STARTER	1	
10*	28462ZH8003	ROPE, RECOIL STARTER	1	
11*	90003ZH8003	SCREW, SETTING	1	
12	90008ZE2003	BOLT, FLANGE 6X10	3	

HONDA GX160K1QXC9 — GASKET KIT ASSY.

GASKET KIT ASSY.

NO ART WORK

HONDA GX160K1QXC9 — GASKET KIT ASSY.

GASKET KIT ASSY.

<u>NO.</u>	<u>PART NO.</u>	<u>PART NAME</u>	<u>QTY.</u>	<u>REMARKS</u>
1*	11381ZH8801	GASKET, CASE COVER (NON- ASBESTOS	1	
2*	12251ZF1800	GASKET, CYLINDER HEAD	1	
3*	12391ZE1000	GASKET, CYLINDER HEAD COVER	1	
4*	16212ZH8800	GASKET, INSULATOR	1	
5*	16221ZH8801	GASKET, CARBURETOR	1	
6*	18381ZH8800	GASKET, MUFFLER	1	
7	06111ZH8405	GASKET KIT	1.....	INCLUDES ITEMS W/*

HONDA GX160K1QXC9 — LABELS ASSY.

LABELS ASSY.

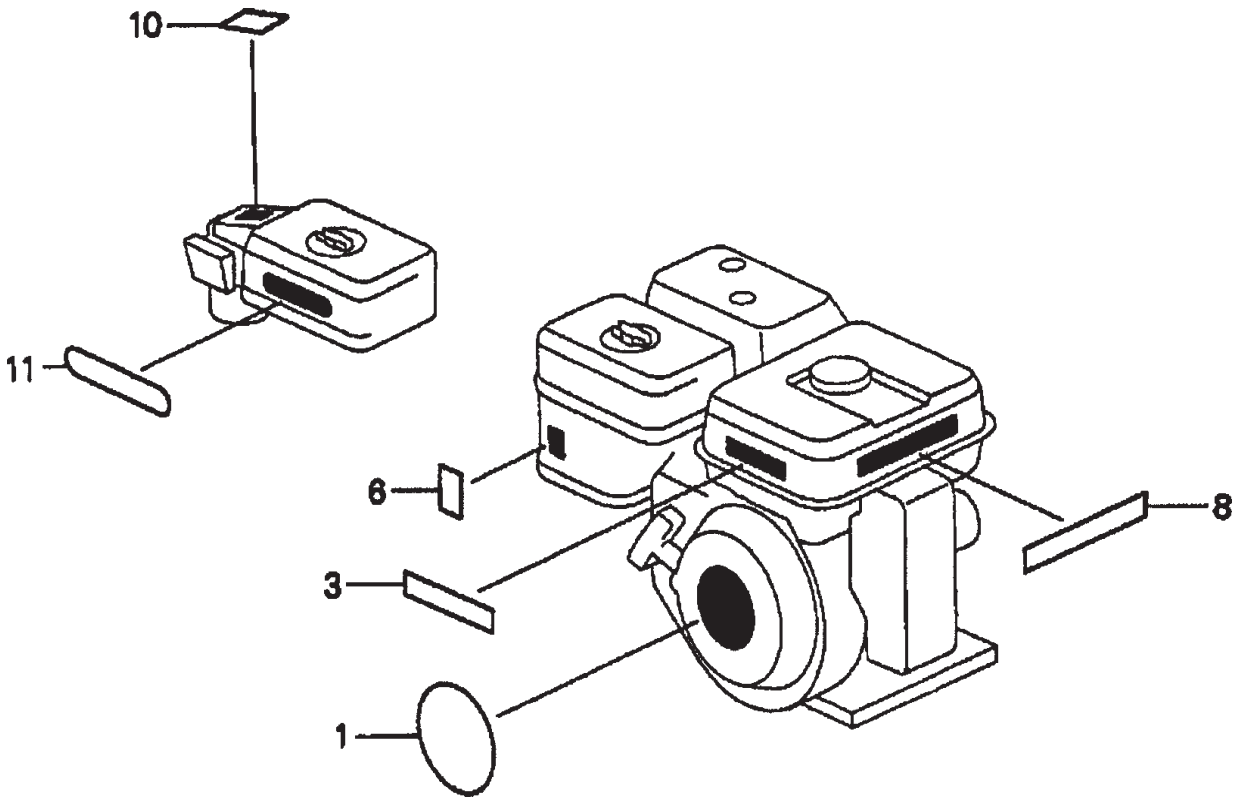

HONDA GX160K1QXC9 — LABELS ASSY.

LABELS ASSY.

<u>NO.</u>	<u>PART NO.</u>	<u>PART NAME</u>	<u>QTY.</u>	<u>REMARKS</u>
1	87521ZH8020	EMBLEM, 5.5	1	
3	87522ZH9000	LABEL, CAUTION	1	
6	87528ZE1810	MARK, CHOKE	1	
8	87532ZH8810	MARK, OIL ALERT (E)	1	
10	87534ZE1841	LABEL, AIR CLEANER CAUTION	1	
11	87535ZE1840	MARK, AIR CLEANER SALES POINT	1	

TERMS AND CONDITIONS OF SALE — PARTS

PAYMENT TERMS

Terms of payment for parts are net 30 days.

FREIGHT POLICY

All parts orders will be shipped collect or prepaid with the charges added to the invoice. All shipments are F.O.B. point of origin. Multiquip's responsibility ceases when a signed manifest has been obtained from the carrier, and any claim for shortage or damage must be settled between the consignee and the carrier.

MINIMUM ORDER

The minimum charge for orders from Multiquip is \$15.00 net. Customers will be asked for instructions regarding handling of orders not meeting this requirement.

RETURNED GOODS POLICY

Return shipments will be accepted and credit will be allowed, subject to the following provisions:

1. A Returned Material Authorization must be approved by Multiquip prior to shipment.
2. To obtain a Return Material Authorization, a list must be provided to Multiquip Parts Sales that defines item numbers, quantities, and descriptions of the items to be returned.
 - a. The parts numbers and descriptions must match the current parts price list.
 - b. The list must be typed or computer generated.
 - c. The list must state the reason(s) for the return.
 - d. The list must reference the sales order(s) or invoice(s) under which the items were originally purchased.
 - e. The list must include the name and phone number of the person requesting the RMA.
3. A copy of the Return Material Authorization must accompany the return shipment.
4. Freight is at the sender's expense. All parts must be returned freight prepaid to Multiquip's designated receiving point.

5. Parts must be in new and resalable condition, in the original Multiquip package (if any), and with Multiquip part numbers clearly marked.
6. The following items are not returnable:
 - a. Obsolete parts. (If an item is in the price book and shows as being replaced by another item, it is obsolete.)
 - b. Any parts with a limited shelf life (such as gaskets, seals, "O" rings, and other rubber parts) that were purchased more than six months prior to the return date.
 - c. Any line item with an extended dealer net price of less than \$5.00.
 - d. Special order items.
 - e. Electrical components.
 - f. Paint, chemicals, and lubricants.
 - g. Decals and paper products.
 - h. Items purchased in kits.
7. The sender will be notified of any material received that is not acceptable.
8. Such material will be held for five working days from notification, pending instructions. If a reply is not received within five days, the material will be returned to the sender at his expense.
9. Credit on returned parts will be issued at dealer net price at time of the original purchase, less a 15% restocking charge.
10. In cases where an item is accepted, for which the original purchase document can not be determined, the price will be based on the list price that was effective twelve months prior to the RMA date.
11. Credit issued will be applied to future purchases only.

PRICING AND REBATES

Prices are subject to change without prior notice. Price changes are effective on a specific date and all orders received on or after that date will be billed at the revised price. Rebates for price declines and added charges for price increases will not be made for stock on hand at the time of any price change.

Multiquip reserves the right to quote and sell direct to Government agencies, and to Original Equipment Manufacturer accounts who use our products as integral parts of their own products.

SPECIAL EXPEDITING SERVICE

A \$35.00 surcharge will be added to the invoice for special handling including bus shipments, insured parcel post or in cases where Multiquip must personally deliver the parts to the carrier.

LIMITATIONS OF SELLER'S LIABILITY

Multiquip shall not be liable hereunder for damages in excess of the purchase price of the item with respect to which damages are claimed, and in no event shall Multiquip be liable for loss of profit or good will or for any other special, consequential or incidental damages.

LIMITATION OF WARRANTIES

No warranties, express or implied, are made in connection with the sale of parts or trade accessories nor as to any engine not manufactured by Multiquip. Such warranties made in connection with the sale of new, complete units are made exclusively by a statement of warranty packaged with such units, and Multiquip neither assumes nor authorizes any person to assume for it any other obligation or liability whatever in connection with the sale of its products. Apart from such written statement of warranty, there are no warranties, express, implied or statutory, which extend beyond the description of the products on the face hereof.

Effective: February 22, 2006

OPERATION AND PARTS MANUAL

HERE'S HOW TO GET HELP

PLEASE HAVE THE MODEL AND SERIAL
NUMBER ON-HAND WHEN CALLING

UNITED STATES

Multiquip Corporate Office

18910 Wilmington Ave. Tel. (800) 421-1244
Carson, CA 90746 Fax (800) 537-3927
Contact: mq@multiquip.com

Mayco Parts

800-306-2926 Fax: 800-672-7877
310-537-3700 Fax: 310-637-3284

Service Department

800-421-1244 Fax: 310-537-4259
310-537-3700

MQ Parts Department

800-427-1244 Fax: 800-672-7877
310-537-3700 Fax: 310-637-3284

Warranty Department

800-421-1244, Ext. 279 Fax: 310-537-1173
310-537-3700, Ext. 279

Technical Assistance

800-478-1244 Fax: 310-631-5032

MEXICO

MQ Cipsa

Carr. Fed. Mexico-Puebla KM 126.5 Tel: (52) 222-225-9900
Momoxpan, Cholula, Puebla 72760 Mexico Fax: (52) 222-285-0420
Contact: pmastretta@cipsa.com.mx

CANADA

Multiquip

4110 Industriel Boul. Tel: (450) 625-2244
Laval, Quebec, Canada H7L 6V3 Tel: (877) 963-4411
Contact: jmartin@multiquip.com Fax: (450) 625-8664

UNITED KINGDOM

Multiquip (UK) Limited Head Office

Unit 2, Northpoint Industrial Estate, Tel: 0161 339 2223
Global Lane, Fax: 0161 339 3226
Dukinfield, Cheshire SK16 4UJ
Contact: sales@multiquip.co.uk

© COPYRIGHT 2010, MULTIQUIP INC.

Multiquip Inc and the MQ logo are registered trademarks of Multiquip Inc. and may not be used, reproduced, or altered without written permission. All other trademarks are the property of their respective owners and used with permission.

This manual MUST accompany the equipment at all times. This manual is considered a permanent part of the equipment and should remain with the unit if resold.

The information and specifications included in this publication were in effect at the time of approval for printing. Illustrations, descriptions, references and technical data contained in this manual are for guidance only and may not be considered as binding. Multiquip Inc. reserves the right to discontinue or change specifications, design or the information published in this publication at any time without notice and without incurring any obligations.

Your Local Dealer is:

