



MQ600HTB

MULTIQUIP® 6" Trash Pump

GALLONS PER MINUTE

1600 (6057 L)

HEAD

150 ft (45.7 M)

ENGINE

Hatz 4H50TIC



APPLICATIONS

Agricultural, Construction Sites, Dirty Water, Emergency Response, Excavation, Farms, Floods, Irrigation, Jobsite Drainage, Mining, Municipalities, Standing Water, Large Swimming Pools, Quarries, Water Departments, Water Supply from Lakes/Rivers

STANDARD FEATURES

- Maximum pumping capacity of **1600 gallons (6057 liters)** per minute.
- Maximum lift of **25 feet (7.6 meters)**
- Maximum head **150 feet (45.7 meters)**
- Cast iron body with cast-iron fittings
- Large cleanout cover for easy cleaning
- Pumps water with solid content as large as **3.0-inch (76.2 mm)** in diameter.
- High-Efficiency impeller and volute for maximum fluid transfer.
- Ductile iron impeller and stainless steel wear plate abrasion resistance/long life.
- Abrasion-resistant oil lubricated tungsten/carbide seal
- **Adjustable 6-inch discharge port** for easy hose orientation and flexibility.
- Heavy duty **Hatz diesel engine, 4-cylinder**, direct injection, turbocharged provides maximum reliability
- EPA emissions certified - **Tier 4 final emissions compliant.**
- Engine oil-alert to protect the engine in the case of low engine oil.
- DOT Certified Trailer w/ integral **40-gallon fuel cell.**

WARRANTY*

MQ600HTB: 24 months from date of purchase.

Hatz 4H50TIC Engine: 36 months from date of purchase.

Hoses: 3 months from date of purchase.

*Refer to the MULTIQUIP NEW PRODUCT LIMITED WARRANTY FOR FULL TERMS AND CONDITIONS.

FEATURES

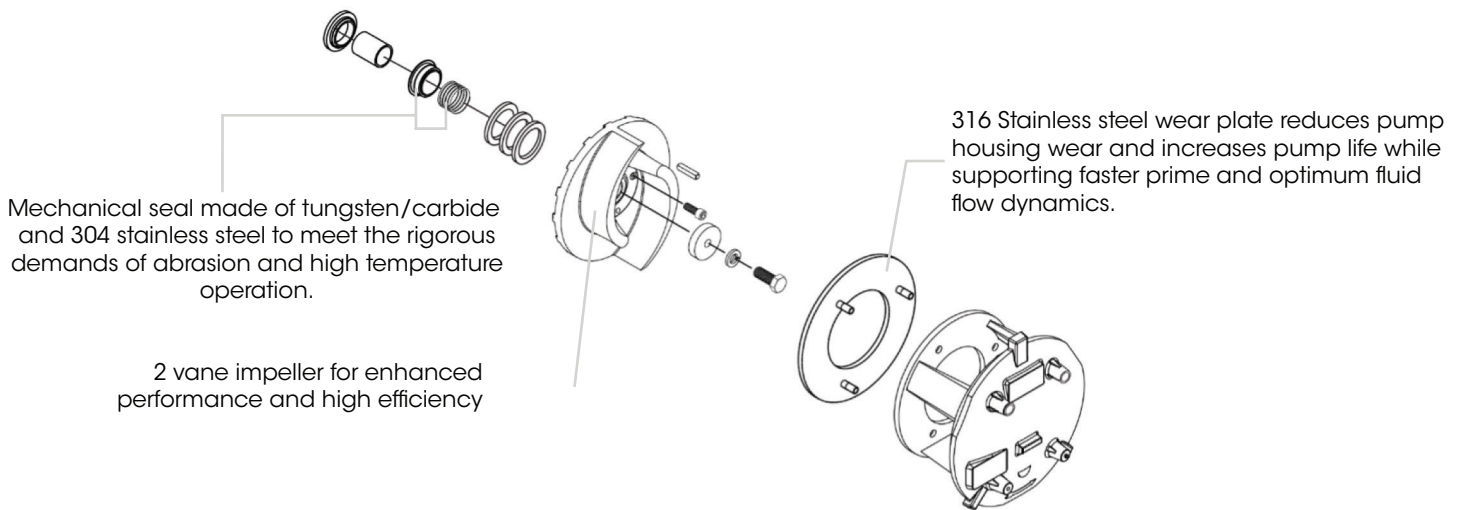
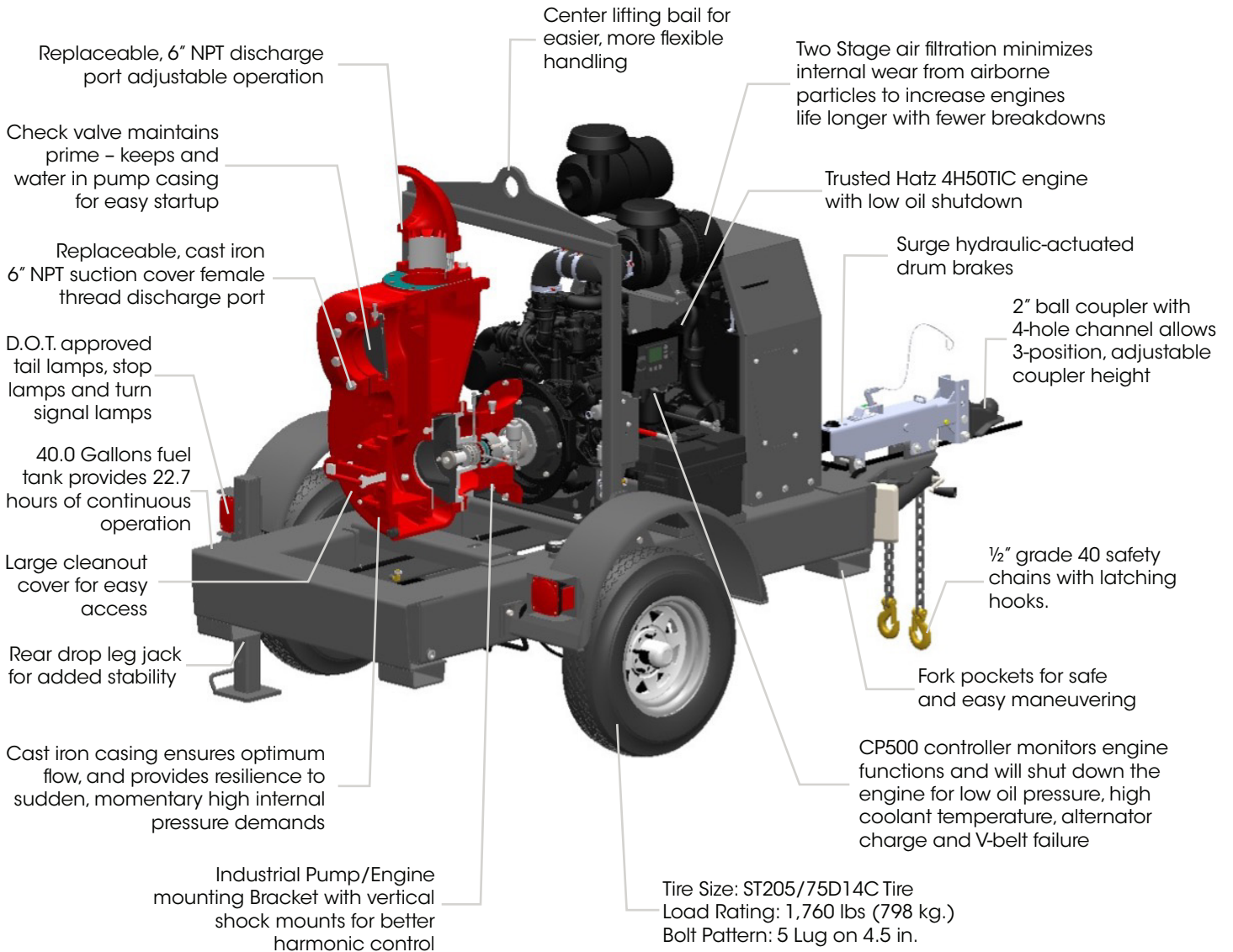

© COPYRIGHT 2026 MULTIQUIP INC. (REV 03242026)

PUMP CURVE

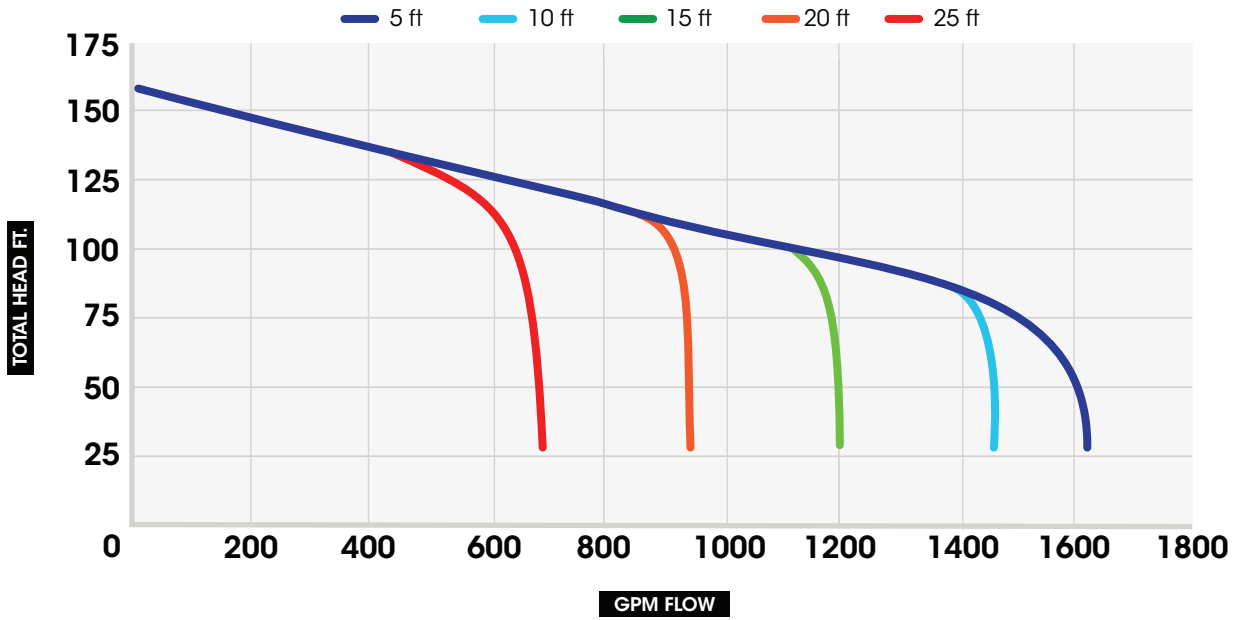

PUMP DIMENSIONS

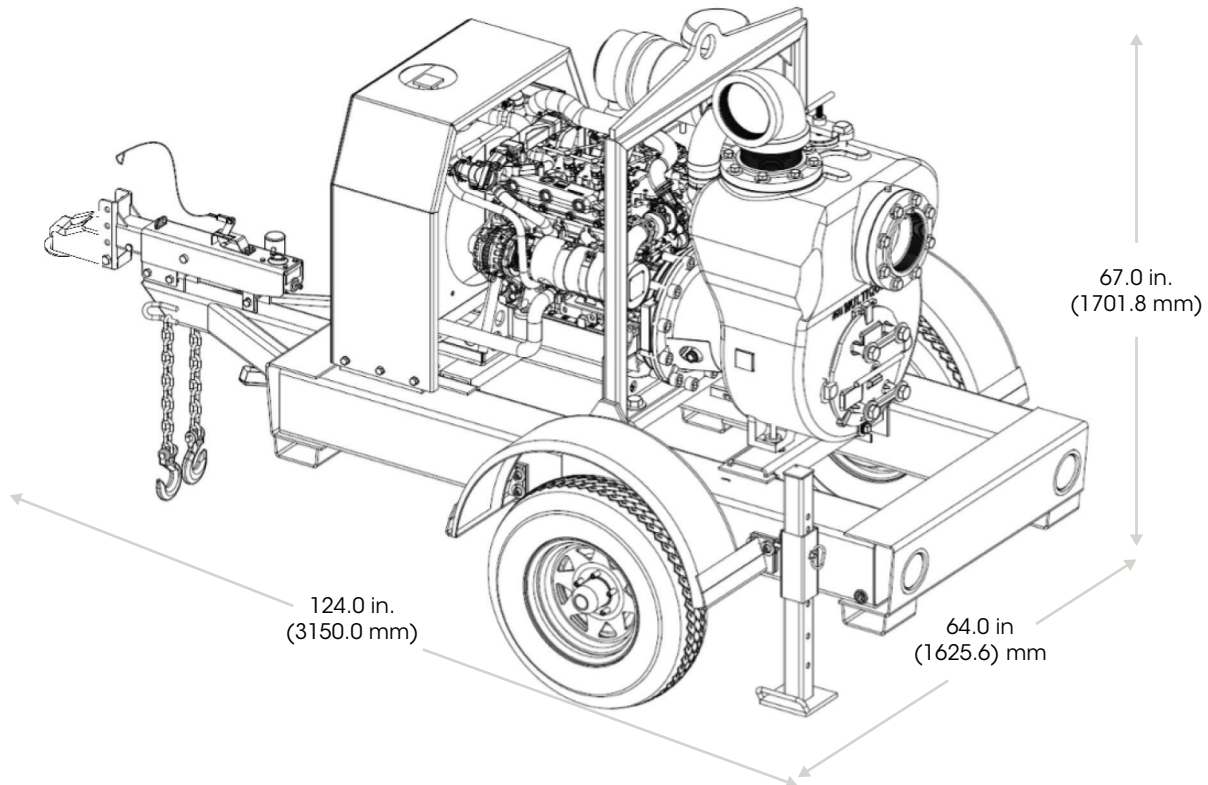

SPECIFICATIONS

PUMP SPECIFICATIONS	
MODEL	MQ600HTB
TYPE	TRASH PUMP
IMPELLER TYPE	SEMI-OPEN
MAX. PUMPING CAPACITY	1600 GALLONS/MINUTE (6057 L/MIN)
MAX. SUCTION	25 FT (7.62 M)
MAX. HEAD	150.0 FT. (45.7 METERS)
SUCTION/DISCHARGE PORT SIZE	6.00 IN. (100 MM)
THREAD TYPE	NPT (FEMALE)
PSI	64.9
IMPELLER MATERIAL	DUCTILE IRON
WEAR PLATE MATERIAL	STAINLESS STEEL
PUMP CASING MATERIAL	CAST IRON
CHECK VALVE MATERIAL	NEOPRENE RUBBER INTERNAL STEEL REINFORCED
MECHANICAL SEAL MATERIAL	OIL LUBRICATED TUNGSTEN/CARBIDE
DRAIN AND FILL CAP MATERIAL	STEEL
SALT OR CHEMICALS	NO
PUMP HARDWARE	STEEL
MAXIMUM FLUID TEMPERATURE	104° F (40° C)
MAXIMUM SOLID HANDING	3.0 IN. (76.2 MM)
O-RINGS	NITRILE BUTADIENE RUBBER
STRAINER SIZE	6.00 IN. (150.0 MM) NPT
STRAINER INLET SIZE	1.46875 IN. (37.3 MM)

ENGINE SPECIFICATIONS	
MAKE/MODEL	HATZ/4H50TC
EMISSIONS	EPA AND CARB CERTIFIED
STARTING METHOD	ELECTRIC START
DESIGN	DIRECT INJECTION, TURBOCHARGER WITH CHARGE AIR COOLING, EGR, DOC
DISPLACEMENT	1952 CC (119 CU-IN)
NUMBERS OF CYLINDERS	4
BORE X STROKE	3.30 IN. X 3.50 IN (84 MM X 89 MM)
HORSE POWER (kW)	68.4 (51.0)
ENGINE SPEED	2,000 RPM
GOVERNOR SPEED	ELECTRONIC
SOUND LEVEL dB(A) AT 23 FT	77
AIR CLEANER	DUAL ELEMENT
LUBRICATION SYSTEM	OIL PUMP
SPARK ARRESTOR	OPTIONAL
OIL CAPACITY	7.4 QUARTS (7.0 LITERS)
OIL TYPE	SAE 10W-30
LOW OIL SHUT-DOWN	STANDARD
BATTERY	12V CA 810A 650 CCA

FUEL SPECIFICATIONS	
RECOMMENDED FUEL	ASTM-D975 - NO. 1 & NO. 2D*
FUEL TANK CAPACITY	40 GALLONS (151.4 LITERS)
FUEL CONSUMPTION	1.76 GPH (3.1 LPH)
RUN TIME	22.7 HOURS
*USE ULTRA-LOW SULFUR DIESEL FUEL	

WEIGHT AND DIMENSIONS	
DRY WEIGHT	2850 LB. (1293 KG)
DIMENSIONS	124.0 X 64.0 X 67.0 IN. (3150 X 1625.6 X 1701.8 MM)

OPTIONS

SUCTION HOSES

- **HS620C** – 6" x 20 ft., 65psi, rigid PVC helix reinforced, NPS thread
- **HSQ620C** – 6" x 20 ft., 65psi, rigid PVC helix reinforced, NPT thread, Male Camlock, includes one quick disconnect coupler
- **HS625C** – 6" x 25 ft., 65psi, rigid PVC helix reinforced, NPS thread
- **HSQ625C** – 6" x 25 ft., 65psi, rigid PVC helix reinforced NPT thread, Male Camlock, includes one quick disconnect coupler
- **A600A** – 6" type A coupler, male quick disconnect x female NPT



HS620C AND HS625C

HSQ620C AND HSQ625C

DISCHARGE HOSES

- **HD650C** – 6" x 50 ft., 45psi, NPS thread
- **HDQ650C** – 6" x 50 ft., 45psi NPT thread, includes one quick disconnect coupler
- **A600A**– 6" type A coupler, male quick disconnect x female NPT
- **A600M**– 6" type F coupler, male quick disconnect x male NPT



HD650C



HDQ650C



A600A



A600M

NOTICE Features and Specifications are subject to change without notice.