

# PARTS MANUAL



## **MODELS** **MQD2HA** **MQD3HA** **DIAPHRAGM PUMP** **(HONDA GX120UT1QX2 GASOLINE ENGINE)**

Revision #1 (02/24/23)

To find the latest revision of this publication or associated operation manual, visit our website at: [www.multiquip.com](http://www.multiquip.com)



**THIS MANUAL MUST ACCOMPANY THE EQUIPMENT AT ALL TIMES.**

## **MQD2HA/3HA Diaphragm-Pumps**

Explanation Of Code In Remarks Column..... 4  
Suggested Spare Parts ..... 5

### **Pump Component Drawings**

Nameplate And Decals Assembly ..... 6-7  
Waterbox And Flap Valve Assembly ..... 8-9  
Pump Assembly ..... 10-11  
Handle, Engine And Wheel Assembly ..... 12-13  
Gearbox Support Bracket Assembly..... 14-15

#### **NOTICE**

Part numbers are subject to change without notice.



# EXPLANATION OF CODE IN REMARKS COLUMN

The following section explains the different symbols and remarks used in the Parts section of this manual. Use the help numbers found on the back page of the manual if there are any questions.

**NOTICE**

The contents and part numbers listed in the parts section are subject to change **without notice**. Multiquip does not guarantee the availability of the parts listed.

## SAMPLE PARTS LIST

NO.	PART NO.	PART NAME	QTY.	REMARKS
1	12345	BOLT .....	1	INCLUDES ITEMS W/%
2%		WASHER, 1/4 IN. ....		NOT SOLD SEPARATELY
2%	12347	WASHER, 3/8 IN. ...	1	MQ-45T ONLY
3	12348	HOSE .....	A/R	MAKE LOCALLY
4	12349	BEARING .....	1	S/N 2345B AND ABOVE

### NO. Column

**Unique Symbols** — All items with same unique symbol (@, #, +, %, or >) in the number column belong to the same assembly or kit, which is indicated by a note in the “Remarks” column.

**Duplicate Item Numbers** — Duplicate numbers indicate multiple part numbers, which are in effect for the same general item, such as different size saw blade guards in use or a part that has been updated on newer versions of the same machine.

**NOTICE**

When ordering a part that has more than one item number listed, check the remarks column for help in determining the proper part to order.

### PART NO. Column

**Numbers Used** — Part numbers can be indicated by a number, a blank entry, or TBD.

TBD (To Be Determined) is generally used to show a part that has not been assigned a formal part number at the time of publication.

A blank entry generally indicates that the item is not sold separately or is not sold by Multiquip. Other entries will be clarified in the “Remarks” Column.

### QTY. Column

**Numbers Used** — Item quantity can be indicated by a number, a blank entry, or A/R.

A/R (As Required) is generally used for hoses or other parts that are sold in bulk and cut to length.

A blank entry generally indicates that the item is not sold separately. Other entries will be clarified in the “Remarks” Column.

### REMARKS Column

Some of the most common notes found in the “Remarks” Column are listed below. Other additional notes needed to describe the item can also be shown.

**Assembly/Kit** — All items on the parts list with the same unique symbol will be included when this item is purchased.

Indicated by:

“INCLUDES ITEMS W/(unique symbol)”

**Serial Number Break** — Used to list an effective serial number range where a particular part is used.

Indicated by:

“S/N XXXXX AND BELOW”

“S/N XXXX AND ABOVE”

“S/N XXXX TO S/N XXX”

**Specific Model Number Use** — Indicates that the part is used only with the specific model number or model number variant listed. It can also be used to show a part is NOT used on a specific model or model number variant.

Indicated by:

“XXXXX ONLY”

“NOT USED ON XXXX”

**“Make/Obtain Locally”** — Indicates that the part can be purchased at any hardware shop or made out of available items. Examples include battery cables, shims, and certain washers and nuts.

**“Not Sold Separately”** — Indicates that an item cannot be purchased as a separate item and is either part of an assembly/kit that can be purchased, or is not available for sale through Multiquip.

## SUGGESTED SPARE PARTS

---

### MQD2HA/D3HA DIAPHRAGM PUMP WITH HONDA GX120UT1QX2 ENGINE

1 to 5 units

Qty.	P/N	Description
3.....	17210ZE0822 .....	ELEMENT AIR CLEANER DUAL
3.....	9807955876.....	SPARK PLUG
1.....	17620Z0T813 .....	CAP, FUEL WITH GASKET
1.....	28462ZH8003.....	ROPE STARTER
1.....	338030000.....	DIAPHRAGM 2-INCH
1.....	337030000.....	DIAPHRAGM 3-INCH
2.....	336007090.....	FLAP VALVE 2-INCH
2.....	335407090.....	FLAP VALVE 3-INCH
1.....	212400000.....	FILL CAP W/GASKET
1.....	C23017000.....	STRAINER 2-INCH
1.....	168000000.....	STRAINER 3-INCH

# NAMEPLATE AND DECALS ASSY.

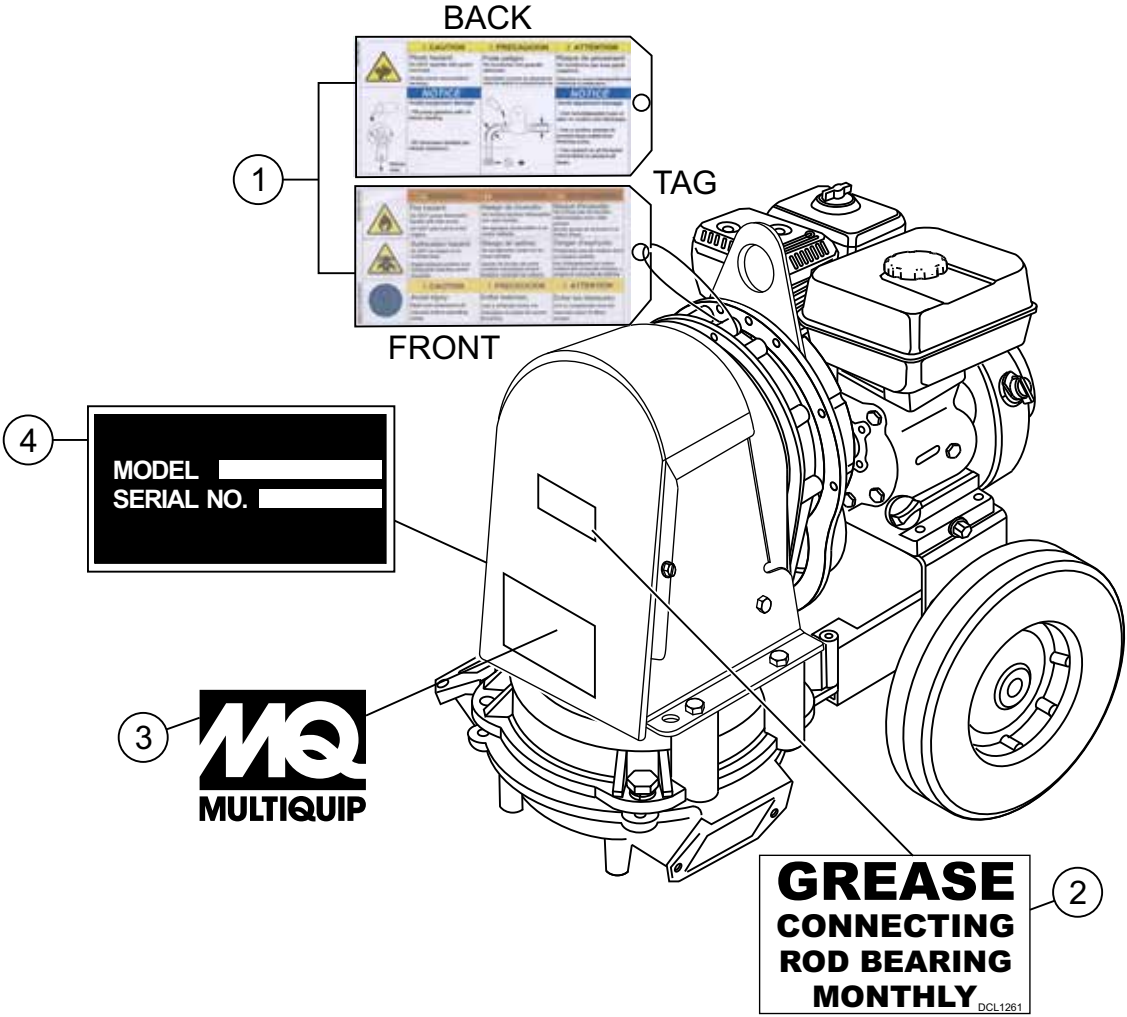

## NAMEPLATE AND DECALS ASSY.

---

<u>NO.</u>	<u>PART NO.</u>	<u>PART NAME</u>	<u>QTY.</u>	<u>REMARKS</u>
1	335925190	DECAL, CAUTION, KIT	1	
2	DCL1261	DECAL, GREASE MONTHLY	1	
3	512910	DECAL, MQ LOGO	1	
4		PLATE, SERIAL NUMBER .....	1	.....CONTACT MQ PARTS DEPT.

# WATERBOX AND FLAP VALVE ASSY.

NOTES:

1 TORQUE TO 16-20 FT. LBS.

2 REFERENCE PUMP ASSY.

3 REFERENCE ITEM 9.

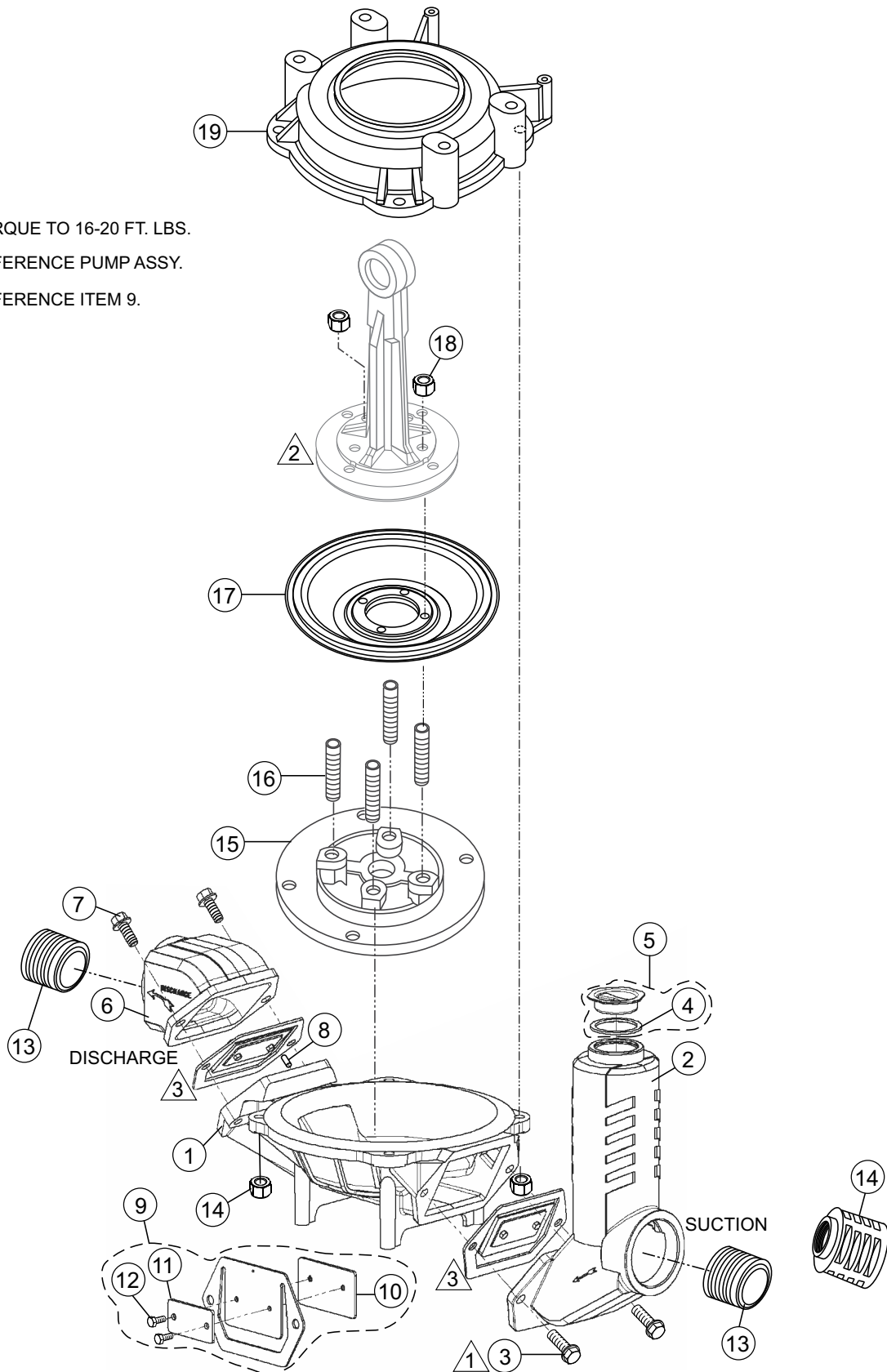



## WATERBOX AND FLAP VALVE ASSY.

<u>NO.</u>	<u>PART NO.</u>	<u>PART NAME</u>	<u>QTY.</u>	<u>REMARKS</u>
1	336000100	WELL.....	1	2-INCH PUMP ONLY
1	212000100	WELL.....	1	3-INCH PUMP ONLY
2	336005000	SUCTION PLATE .....	1	2-INCH PUMP ONLY
2	212300000	SUCTION PLATE .....	1	3-INCH PUMP ONLY
3	175700700	HEX FLANGE SCREW, 3/8"-16 X 1-1/4" GRD. 5.....	2	2-INCH PUMP ONLY
3	176601000	HEX FLANGE SCREW, 1/2"-13 X 1-1/4" GRD. 5.....	2	3-INCH PUMP ONLY
4\$		GASKET	1	
5	212400000	FILL CAP.....	1	INCLUDES ITEMS W/\$
6\$	336005201	DISCHARGE PLATE	1	
7	175700700	HEX FLANGE SCREW, 3/8"-16 X 1-1/4" GRD. 5.....	2	2-INCH PUMP ONLY
7	176601000	HEX FLANGE SCREW, 1/2"-13 X 1-1/4" GRD. 5.....	2	3-INCH PUMP ONLY
8	212100000	PIN, 1/8" DIA. X 3/8"	2	
9	336007090	CHECK VALVE NEOPRENE/ASSY. KIT, 2-INCH.....	2	INCLUDES ITEMS W/%
9	335407090	CHECK VALVE NEOPRENE/ASSY. KIT, 3-INCH.....	2	INCLUDES ITEMS W/#
10%#		CHECK VALVE WEIGHT TOP	1	
11%#		CHECK VALVE WEIGHT BOTTOM	1	
12%#		HEX HEAD CAP SCREW, 1/4"-20 X 1/2"	2	
13	C36699990	NPT PIPE NIPPLES (PACK OF TWO) .....	1	2-INCH PUMP ONLY
13	327017390	NPT PIPE NIPPLES (PACK OF TWO) .....	1	3-INCH PUMP ONLY
14	C23017000	NPT STRAINER 3/8" HOLES.....	1	2-INCH PUMP ONLY
14	168000000	NPT STRAINER 3/8" HOLES.....	1	3-INCH PUMP ONLY
15	338009200	DIAPHRAGM RETAINER PLATE .....	1	2-INCH PUMP ONLY
15	337002000	DIAPHRAGM RETAINER PLATE .....	1	3-INCH PUMP ONLY
16	176001200	3/8"-16 X 2" SOCKET SCREW CUP, PT 18-8S.....	4	2-INCH PUMP ONLY
16	176600700	7/16"-14 X 2" LG SOCKET SET SCREW .....	4	3-INCH PUMP ONLY
17	338030000	DIAPHRAGM.....	1	2-INCH PUMP ONLY
17	337030000	DIAPHRAGM.....	1	3-INCH PUMP ONLY
18	178000000	NUT, HEX 3/8"-16.....	4	2-INCH PUMP ONLY
18	176603600	NUT, HEX HEAVY 7/16" .....	4	3-INCH PUMP ONLY
19	336002001	BASE .....	1	2-INCH PUMP ONLY
19	335400100	BASE.....	1	3-INCH PUMP ONLY

# PUMP ASSY.

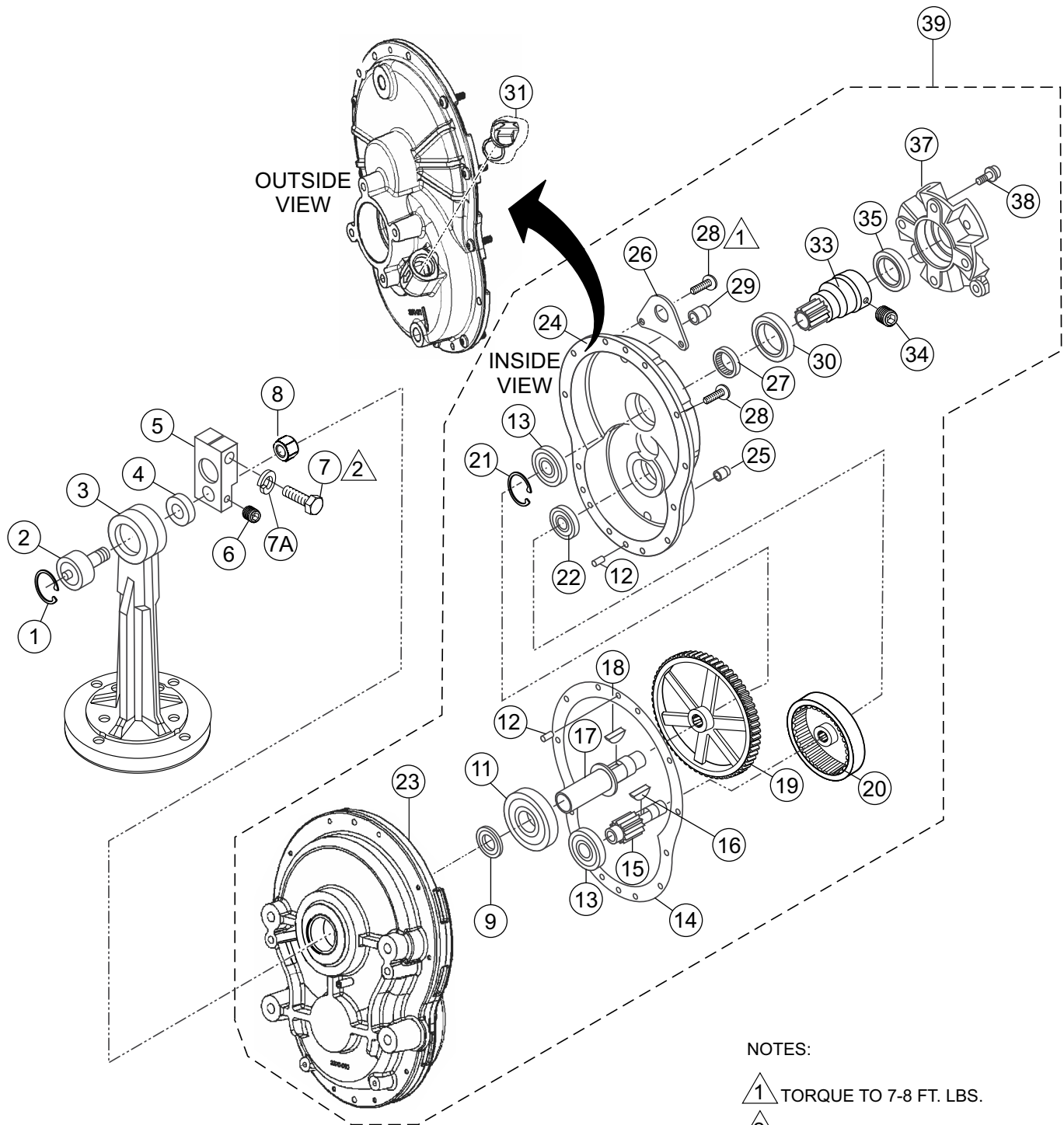

## PUMP ASSY.

<u>NO.</u>	<u>PART NO.</u>	<u>PART NAME</u>	<u>QTY.</u>	<u>REMARKS</u>
1	336019100	INTERNAL RETAINING RING 1-1/2" .....	1	2-INCH ONLY
1	335019000	INTERNAL RETAINING RING .....	1	3-INCH ONLY
2	336019090	PLUNGER BEARING .....	1	INCLUDES ITEM W/#
2	213800090	PLUNGER BEARING .....	1	INCLUDES ITEM W/&
3	336009002	PLUNGER ARM .....	1	2-INCH ONLY
3	213400002	PLUNGER ARM .....	1	3-INCH ONLY
4\$+		BEARING SHIM	1	
5	336009490	CRANK ASSEMBLY KIT .....	1	INCLUDES ITEMS W/\$
5	214000090	CRANK ASSEMBLY KIT .....	1	INCLUDES ITEMS W/+
6\$+		SOCKET SET SCREW 5/16"-18 X 1/2"	1	
7\$+		BOLT, 1/2"-13 X 2-3/4"	1	
7A\$+		WASHER, LOCK	1	
8#&		NUT	1	
9% @	214800000	OIL SEAL 1-1/4" X 1-3/4" X 1/4"	1	
10% @	337009001	GEAR BOX OUTPUT HALF	1	
11% @	335419000	OUTPUT BALL BEARING #6307	1	
12% @	171700200	DOWEL PIN, 1/4" X 1"	2	
13% @	335419100	INTERMED. BALL BEARING #6304, 20X52X15	2	
14% @	335430000	GASKET	1	
15% @	335412100	IDLER PINION SHAFT	1	
16% @	215700000	WOODRUFF KEY #406 1/8" X 3/4"	1	
17%	335414100	OUTPUT SHAFT .....	1	2-INCH ONLY
17 @	335414000	OUTPUT SHAFT .....	1	3-INCH ONLY
18% @	214100000	WOODRUFF KEY #1008 5/16" X 1"	1	
19% @	335412000	OUTPUT GEAR	1	
20% @	214900000	INTERNAL SPUR GEAR	1	
21% @	180606400	EXTERNAL RETAINING RING 1-1/8"	1	
22% @	335419200	IDLER BALL BEARING #6302, 15X42X13	1	
23% @	337009001	GEAR BOX OUTPUT HALF	1	
24% @	337009101	GEAR BOX INPUT HALF	1	
25% @	176700200	NPT PIPE PLUG 1/4"	2	
26% @	335410600	LIFT BRACKET	1	
27% @	337009400	BEARING, NEEDLE 30X37X12	1	
28% @	171800700	BOLT 1/4"-20 X 1"	12	
29% @	176700900	NPT PIPE PLUG 1/4"	1	
30% @	335419400	INPUT PINION BALL BEARING #6007, 35X62X14	1	
31% @	3SXB17090	NPT PLUG AND O-RING, 1/2"	1	
33% @	337012200	INPUT PINION BALL BEARING KEYED	1	
34% @	171100100	SET SCREW, 1/4-20" X 1/4"	1	
35% @	214800100	OIL SEAL	1	
37% @	337009301	ADAPTER, GASOLINE ENGINE	1	
38% @	174500200	FLANGE SCREW, 5/16"-18 X 3/4"	4	
39	338040290	GEARBOX ASSY., COMPLETE 2-INCH .....	1	INCLUDES ITEMS W/%
39	337040290	GEARBOX ASSY., COMPLETE 3-INCH .....	1	INCLUDES ITEMS W/@

# HANDLE, ENGINE AND WHEEL ASSY.

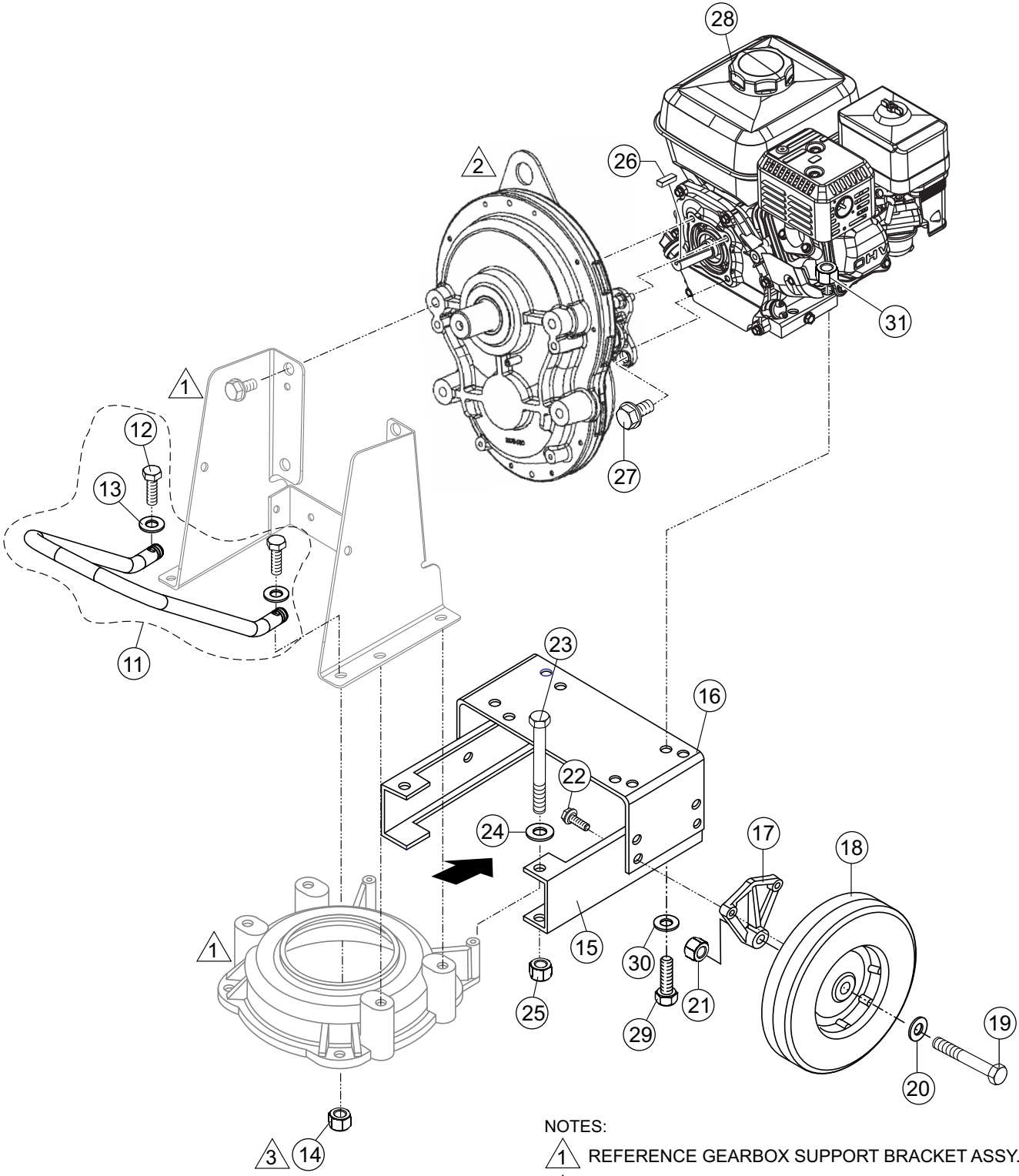

- NOTES:
- ① REFERENCE GEARBOX SUPPORT BRACKET ASSY.
  - ② REFERENCE PUMP ASSY.
  - ③ INCLUDED WITH ITEM 11, HANDLE KIT.

## HANDLE, ENGINE AND WHEEL ASSY.

<u>NO.</u>	<u>PART NO.</u>	<u>PART NAME</u>	<u>QTY.</u>	<u>REMARKS</u>
11	337011690	HANDLE/KIT .....	1	INCLUDES ITEMS W/%
12%		HEX HEAD BOLT, 1/2"-13 X 1-3/4"	2	
13%		FLAT WASHER, 1/2"	2	
14%		HEX NUT, 1/2"-13	2	
15	335410700	MOUNT BRACE	2	
16	335410800	ENGINE MOUNT	1	
17	335410900	WHEEL BRACKET	2	
18	166300000	WHEEL	2	
19	176900000	HEX HEAD BOLT, 5/8"-11 X 4"	2	
20	179900000	FLAT WASHER, 5/8"	2	
21	178202200	HEX NUT, 5/8"-11	2	
22	174500200	HEX FLANGE SCREW, 5/16"-18 X 3/4"	4	
23	173401300	HEX BOLT, 1/4"-20 X 3	2	
24	178900000	FLAT WASHER, 1/4"	2	
25	177600000	HEX NUT, 1/4"-20	2	
26	151700100	SQUARE KEY, 3/16" X 1-1/2"	1	
27	175300000	HEX FLANGE SCREW, 5/16"-24 X 1"	4	
28	163000700	ENGINE, HONDA GX120UT1QX2	1	
29	174800000	HEX BOLT, 5/16"-18 X 1-1/2"	4	
30	179000000	FLAT WASHER, 5/16"	4	
31	178500000	HEX NUT, 5/16"-18	4	

# GEARBOX SUPPORT BRACKET ASSY.

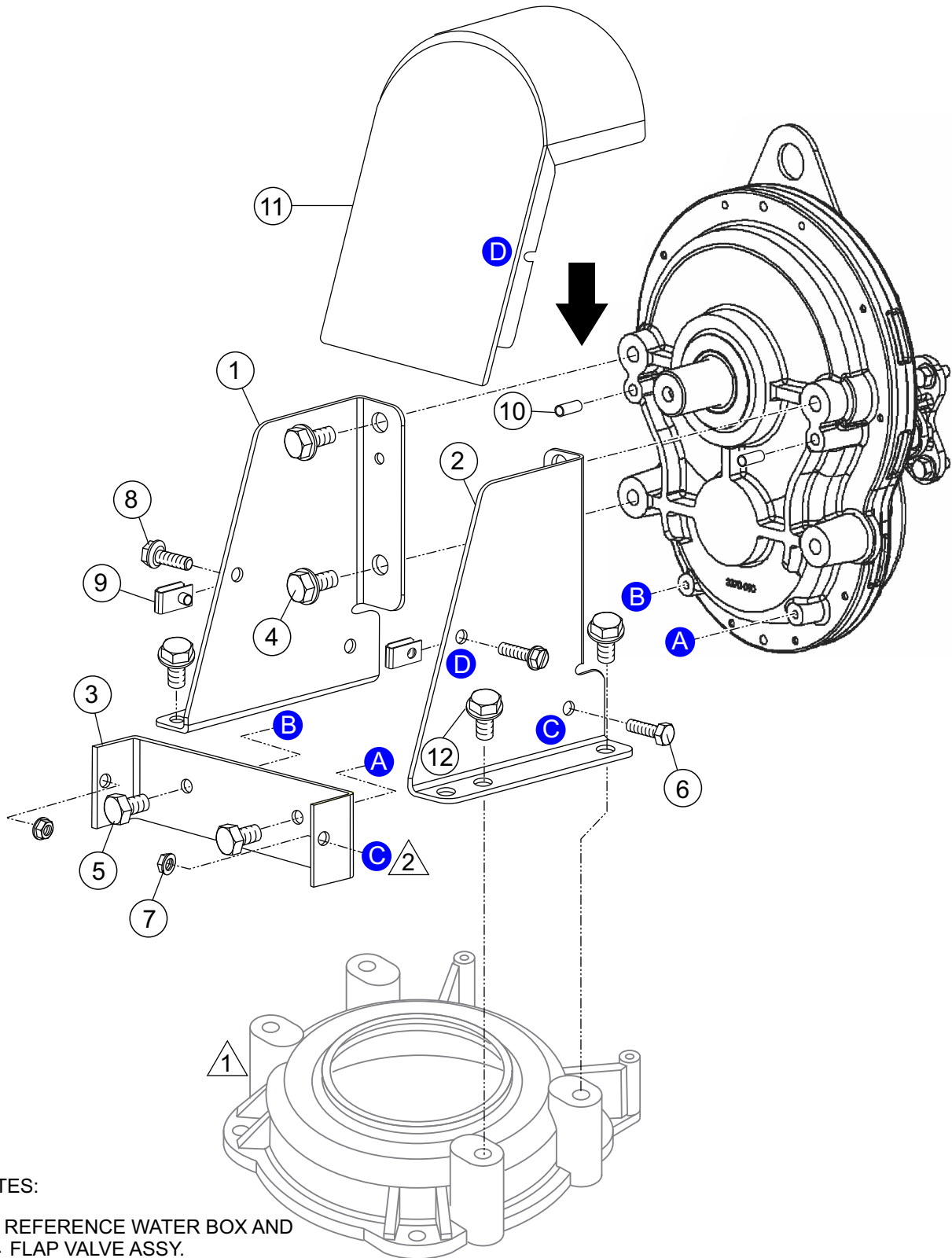

NOTES:

1 REFERENCE WATER BOX AND FLAP VALVE ASSY.

2 BLUE CIRCLES WITH WHITE LETTERS INDICATE CONNECTION/ATTACHMENT POINTS.

## **GEARBOX SUPPORT BRACKET ASSY.**

---

<u>NO.</u>	<u>PART NO.</u>	<u>PART NAME</u>	<u>QTY.</u>	<u>REMARKS</u>
1	337010100	STEEL LEG, LEFT	1	
2	337010000	STEEL LEG, RIGHT	1	
3	337010200	C GUARD	1	
4	176606500	HEX, FLANGE SCREW, 1/2"-13 X 3/4"	4	
5	171500100	SCREW, 1/4"-20 X 1/2"	2	
6	171900000	SCREW, 1/4"-20 X 3/4"	2	
7	177600000	FLANGE NUT, 1/4"-20	2	
8	172200000	HEX FLANGE SCREW, 1/4"-20 X 3/4"	2	
9	176901100	CLIP NUT, 1/4"-20	2	
10	176901000	SPRING PIN, 5/16" X 3/4"	2	
11	337010292	PLUNGER GUARD	1	
12	176606500	FLANGE BOLT 1/2"-13 X 3/4	4	

# PARTS MANUAL

## HERE'S HOW TO GET HELP

PLEASE HAVE THE MODEL AND SERIAL  
NUMBER ON-HAND WHEN CALLING

### UNITED STATES

#### *Multiquip Inc.*

(310) 537- 3700  
6141 Katella Avenue Suite 200  
Cypress, CA 90630  
E-MAIL: [mq@multiquip.com](mailto:mq@multiquip.com)  
WEBSITE: [www.multiquip.com](http://www.multiquip.com)

---

### CANADA

#### *Multiquip*

(450) 625-2244  
4110 Industriel Boul.  
Laval, Quebec, Canada H7L 6V3  
E-MAIL: [infocanada@multiquip.com](mailto:infocanada@multiquip.com)

### UNITED KINGDOM

#### *Multiquip (UK) Limited Head Office*

0161 339 2223  
Unit 2, Northpoint Industrial Estate,  
Globe Lane,  
Dukinfield, Cheshire SK16 4UJ  
E-MAIL: [sales@multiquip.co.uk](mailto:sales@multiquip.co.uk)

© COPYRIGHT 2023, MULTIQUIP INC.

Multiquip Inc, the MQ logo are registered trademarks of Multiquip Inc. and may not be used, reproduced, or altered without written permission. All other trademarks are the property of their respective owners and used with permission.

This manual MUST accompany the equipment at all times. This manual is considered a permanent part of the equipment and should remain with the unit if resold.

The information and specifications included in this publication were in effect at the time of approval for printing. Illustrations, descriptions, references and technical data contained in this manual are for guidance only and may not be considered as binding. Multiquip Inc. reserves the right to discontinue or change specifications, design or the information published in this publication at any time without notice and without incurring any obligations.

