



Walk-Behind Trowels

Handle/Throttle Assembly Installation

The following instructions are intended to assist the user in the installation of the Folding Handle (FXHS) and Edger Folding Handle (FXHSe). It is not intended to take the place of the Operation and Parts Manual shipped with the trowel. Refer to the Operation and Parts Manual for SAFETY, OPERATION, and MAINTENANCE Information. If you did not receive a manual with your trowel, contact Multiquip at (800) 421-1244 for a replacement.

REQUIRED TOOLS

- Ratchet/Socket set
- Wrench
- Phillips Screwdriver

PARTS

Verify that all parts are accounted for. See Figure 1 and Table 1.

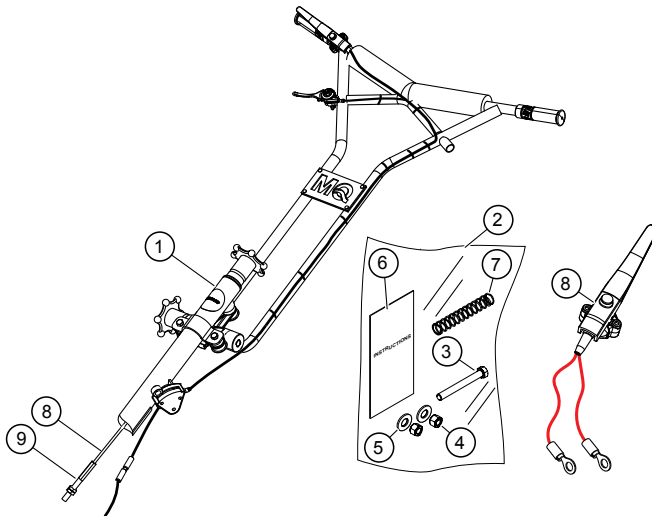

Figure 1. Folding Trowel Handle (FXHS/FXHSe)

Table 1. Handle Parts

Item No.	Part No.	Description	Qty.	Remarks
1	FXHS	Folding Handle	1	Includes item 2,9
1	FXHSe	Edger, Folding Handle	1	Includes items 2,8
2	24012	Kit, Folding Handle Installation	1	Includes items 3-7
3	1493	3/8-16 x 3 1/4 HHC Screw	1	
4	10133	3/8-16 Nyloc Nut	2	
5	10136	3/8 Flat Washer	2	
6	24013	Installation Instructions, FXHS/FXHSe	1	
7	21746	Spring, Primary Throttle Return	1	
8	24072-16	Cable, Pitch Control 16.5" Long	1	
9	24072-21	Cable, Pitch Control 21.5" Long	1	
10	24083	Operator Presence Kit	1	Optional

WORK SAFELY!

Only a **qualified service technician** with proper training should perform this installation. Follow all shop safety rules when performing this installation.

PREPARATION

1. Make sure trowel is turned off and engine is cool.
2. Place the trowel in an area free of dirt and debris. Make sure it is on secure level ground.

UNPACKING THE TROWEL

This trowel may be equipped with a folding upper handle (Figure 2). Trowels utilizing a folding handle are shipped with the handle in the folded or stowed position.

1. To place the folding upper handle in the operational position, simply turn the star wheel counterclockwise to release it from its folded or stowed position.
2. Next, pull back on the upper handle and place handle in the desired position. Turn star wheel clockwise to lock handle in place. Make sure handle is locked firmly in place so that the handle will not move or slip.

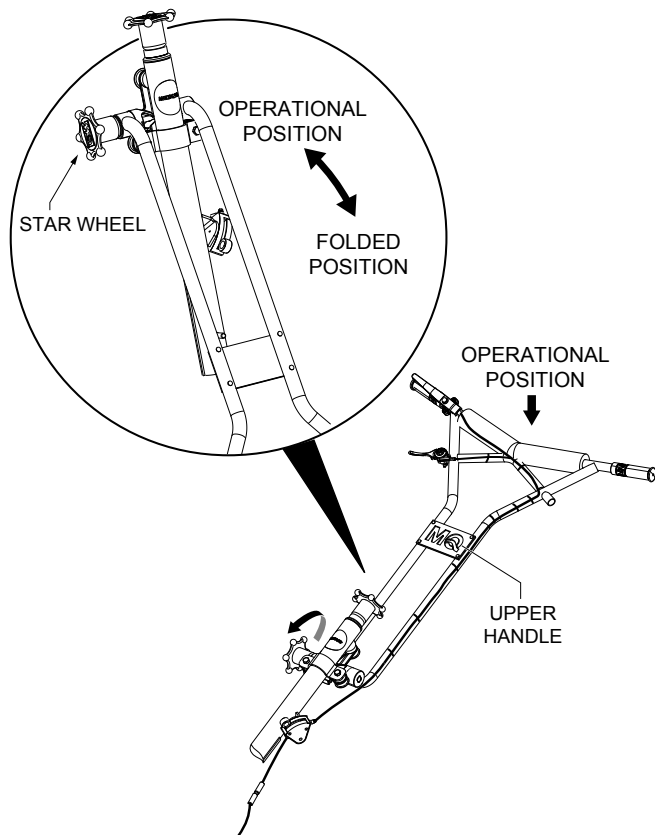

Figure 2. Unpacking the Trowel

MAIN HANDLE TUBE INSTALLATION

1. Attach the main handle tube to the gearbox using the supplied hardware as shown in Figure 3.

NOTICE

The main handle tube fits tightly into the gearbox and may require holding the T-handle bar level while tightening the nut securing the handle to the trowel.

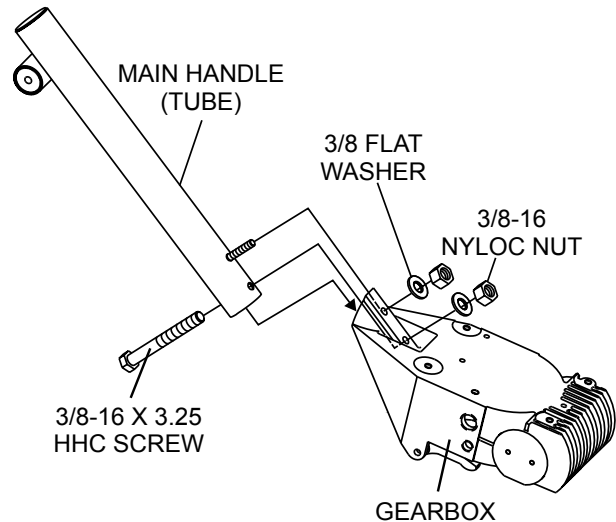

Figure 3. FXHS Handle Installation

2. The upper handle is already attached to the main handle tube.

3. If readjustment is necessary, loosen the star wheel as shown in Figure 4 and move the upper handle to the desired position.

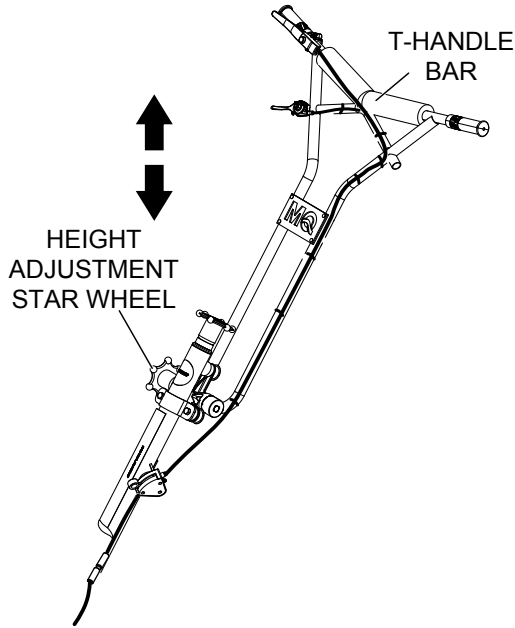

Figure 4. T-Handle Bar Adjustment

FXHS BLADE PITCH CABLE INSTALLATION

1. For trowels equipped with a **Folding** handle (FXHS), simply turn the **star wheel** counterclockwise to pitch the blades flat. This will release the tension on the blade pitch cable (Figure 5).

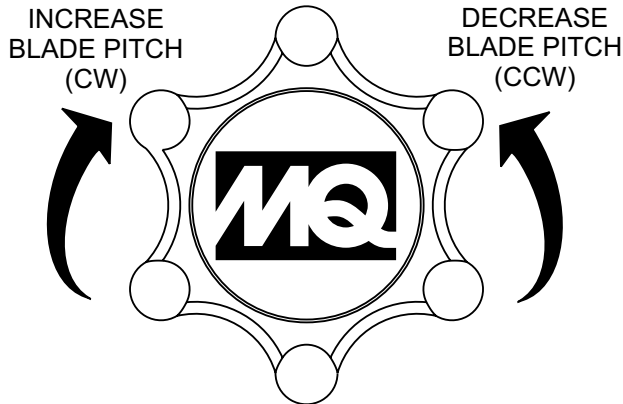

Figure 5. Adjusting Cable Blade Pitch (Folding Handle)

2. Remove brass set nut #1 from the blade pitch cable end. See Figure 6.

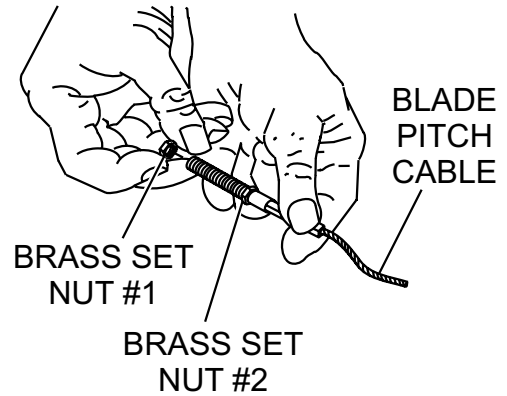

Figure 6. Blade Pitch Cable

3. Thread the brass set nut #2 towards the cable as far as possible. See Figure 6.
4. Insert the cable end through the yoke eyelet (Figure 7). Tighten brass set nut #1 by hand to remove all the slack from the cable.

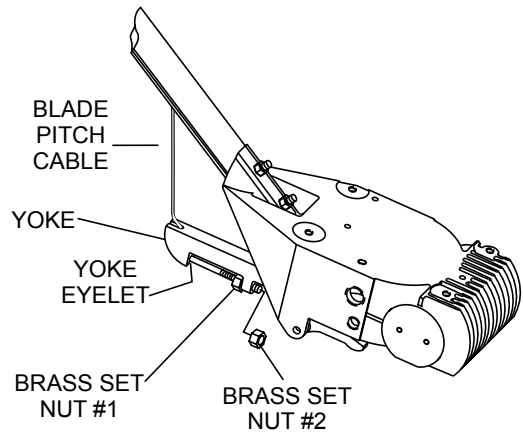

Figure 7. Cable Yoke Attachment

5. Using a wrench, tighten the brass set nut #1 up against brass set nut #2. This will lock the cable in place.

FXHSe BLADE PITCH CABLE INSTALLATION

1. For trowels equipped with a **Edger-Folding** handle (FXHSe), simply turn the **star wheel** counterclockwise to pitch the blades flat. This will release the tension on the blade pitch cable (Figure 8).

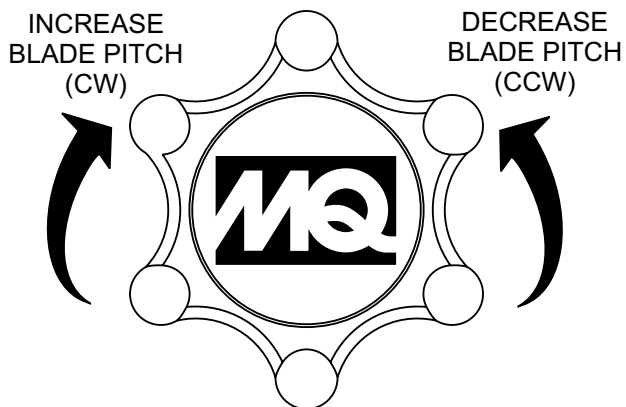

Figure 8. Adjusting Cable Blade Pitch (Folding Handle)

2. Remove brass set nuts #1 and #2 from the blade pitch cable end as shown in (Figure 9).

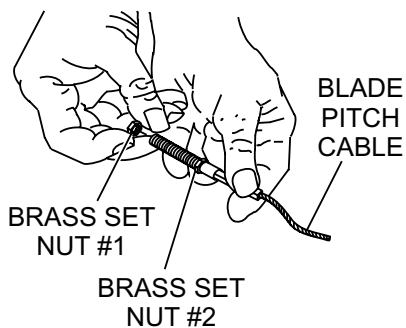

Figure 9. Blade Pitch Cable

3. Insert the cable end through the yoke eyelet (Figure 10). Tighten conical nut #1 by hand to remove all the slack from the cable.

NOTICE

Nut #1 has a chamfer (taper) on the top. Put the nut on with the chamfer (taper) against the yoke.

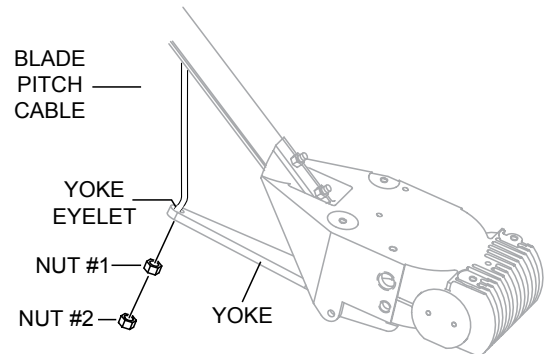

Figure 10. Pitch Cable Yoke Attachment

4. Using a wrench, tighten the brass set nut up against the conical nut. This will lock the cable in place.

THROTTLE CABLE INSTALLATION

Refer to Figure 11 for the location of components.

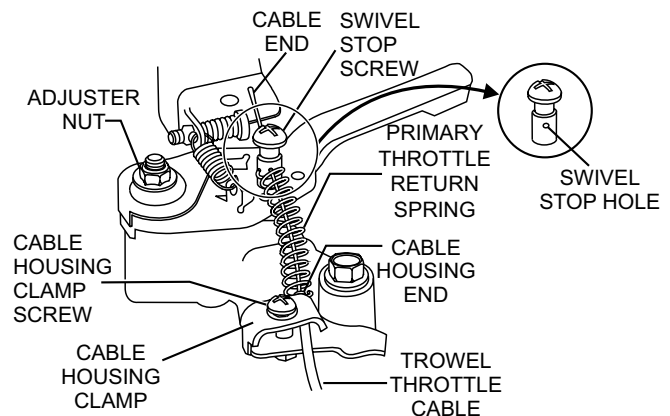

Figure 11. Throttle Cable Installation

1. Uncoil the throttle cable and housing.
2. Check that the throttle cable is fed through the tube on the underside of the handle and secured to the upper handle and main tube with the zip ties.
3. Place the throttle in the idle position.

4. Back off both the cable housing clamp screw and the swivel stop screw.
5. Place the primary throttle return spring (P/N 21746) between the cable housing clamp and the swivel stop screw.
6. Feed the cable assembly through the cable housing clamp, primary throttle return spring, and swivel stop hole, until the cable housing extends under the housing clamp to its far edge.
7. Ensure that the cable housing is seated in the throttle cable receiver. Tighten the cable housing clamp screw.
8. Pull cable end with pliers to remove slack.
9. Tighten swivel stop screw to clamp cable.
10. Adjust cable tension by loosening the lock nut on the throttle cable receiver (see Figure 12), loosening or tightening the adjusting nut below it, then retightening the lock nut.

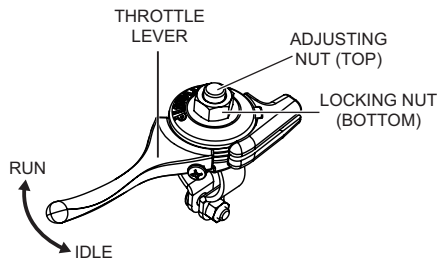

Figure 12. Adjusting Cable Tension

NOTICE

If the throttle lever does not return to the "neutral" position with throttle backed off, loosen adjusting nut 1/2 turn at a time, tighten and recheck. Readjust throttle tension as necessary.

Centrifugal Stop Switch and Operator Presence Switch Connection

NOTICE

Centrifugal Safety Stop switches are equipped with 2 wires. Connect bottom **BLACK/RED** wire (Figure 13) directly to engine ground.

NOTICE

Operator Presence switches are equipped with 2 wires. Connect bottom **RED** wires (Figure 13) directly to the Centrifugal Stop Switch top and bottom connections.

1. Connect the two operator presence switch red wires to the centrifugal stop switch terminal ring connections. One red wire will connect to top and the other to the bottom terminal ring connection.
2. Connect the black tail wire from the engine to the **top black** safety stop wire from the centrifugal stop switch as shown in Figure 13.
3. Using a 10MM socket, remove the existing bottom mounting screw on the recoil starter cover (Figure 13) and connect the **bottom black/red** wire from the centrifugal stop switch.
4. Reinstall mounting screw and tighten securely.
5. Check that the wires are secured to the main tube with zip ties.

WIRING DIAGRAM

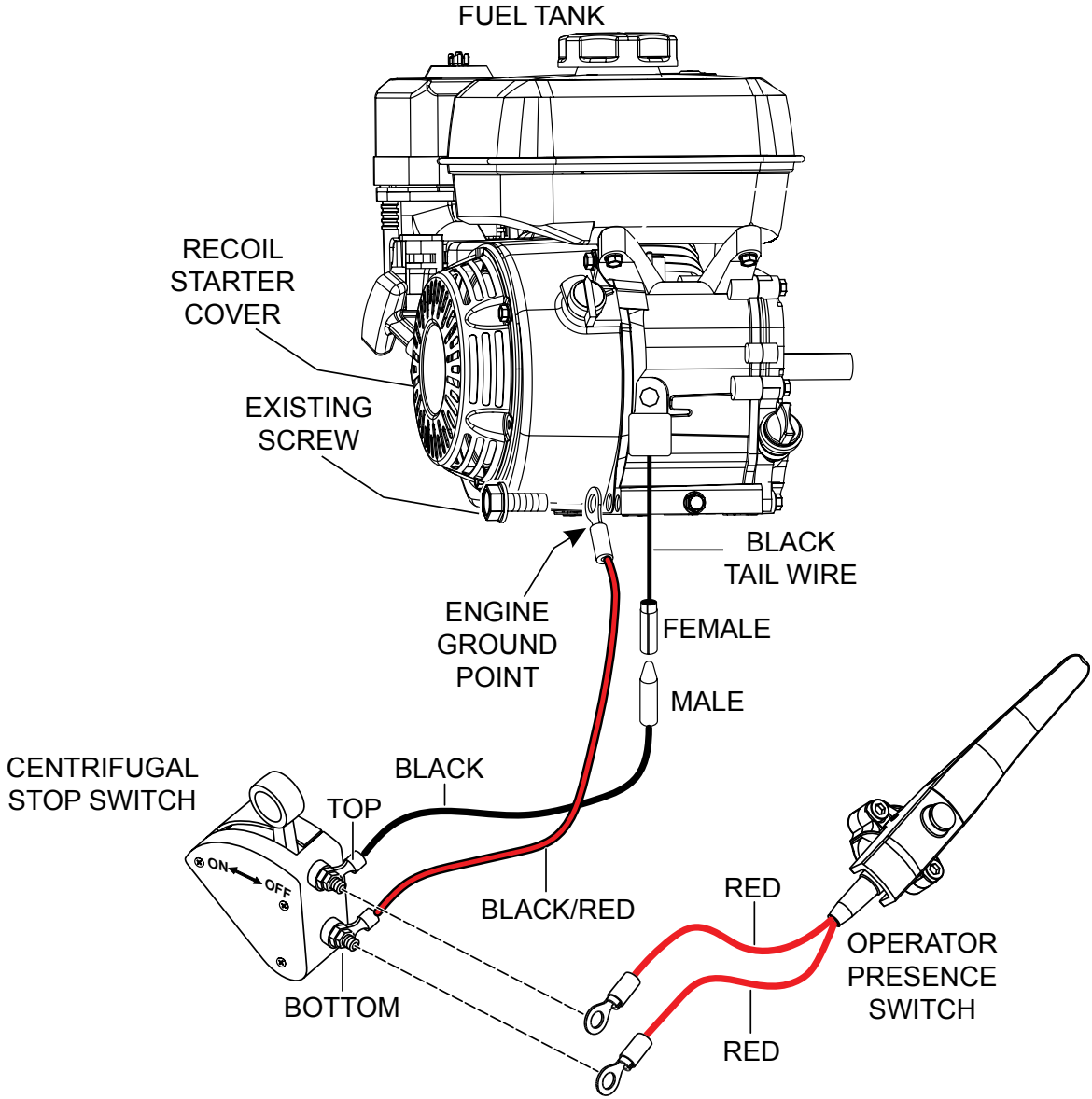

Figure 13. Safety Stop Switch Connections



Walk-Behind Trowels

Handle/Throttle Assembly Installation

HERE'S HOW TO GET HELP

PLEASE HAVE THE MODEL AND SERIAL
NUMBER ON-HAND WHEN CALLING

UNITED STATES

Multiquip Corporate Office

18910 Wilmington Ave. Tel. (800) 421-1244
Carson, CA 90746 Fax (310) 537-3927
Contact: mq@multiquip.com

Service Department

800-421-1244 Fax: 310-537-4259
310-537-3700

Technical Assistance

800-478-1244 Fax: 310-943-2238

MQ Parts Department

800-427-1244 Fax: 800-672-7877
310-537-3700 Fax: 310-637-3284

Warranty Department

800-421-1244 Fax: 310-943-2249
310-537-3700

CANADA

Multiquip

4110 Industriel Boul. Tel: (450) 625-2244
Laval, Quebec, Canada H7L 6V3 Tel: (877) 963-4411
Contact: infocanda@multiquip.com Fax: (450) 625-8664

UNITED KINGDOM

Multiquip (UK) Limited Head Office

Unit 2, Northpoint Industrial Estate, Tel: 0161 339 2223
Globe Lane, Fax: 0161 339 3226
Dukinfield, Cheshire SK16 4UJ
Contact: sales@multiquip.co.uk

© COPYRIGHT 2016, MULTIQUIP INC.

Multiquip Inc and the MQ logo are registered trademarks of Multiquip Inc. and may not be used, reproduced, or altered without written permission. All other trademarks are the property of their respective owners and used with permission.

The information and specifications included in this publication were in effect at the time of approval for printing. Illustrations, descriptions, references and technical data contained in this document are for guidance only and may not be considered as binding. Multiquip Inc. reserves the right to discontinue or change specifications, design or the information published in this publication at any time without notice and without incurring any obligations.

Your Local Dealer is:

