

# OPERATION MANUAL



*Mikasa* SERIES  
**MODEL MRH800GS**  
**Vibratory Roller**  
**(HONDA GX390K1SM32/GX390U1SM32/  
GX390UT2SM32/GX390UT2SCM1  
GASOLINE ENGINES)**

Revision #10 (06/11/20)

To find the latest revision of this publication or  
associated parts manual, visit our website at:  
[www.multiquip.com](http://www.multiquip.com)



**THIS MANUAL MUST ACCOMPANY THE EQUIPMENT AT ALL TIMES.**

**PROPOSITION 65 WARNING**

---

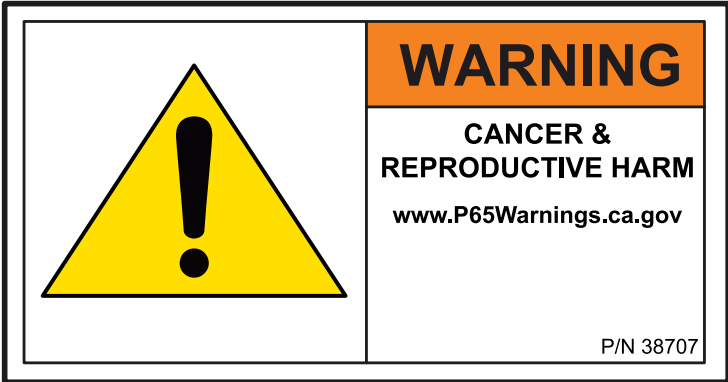



# TABLE OF CONTENTS

---

## **MRH800GS Vibratory Roller**

Proposition 65 Warning .....	2
Safety Information .....	5–9
Specifications (Roller).....	10
Specifications (Engine).....	11
Dimensions.....	12
General Information.....	13
Roller Components.....	14–17
Engine Components .....	18
Inspection .....	19–20
Operation.....	21–23
Maintenance.....	24–30
Electromagnetic Clutch.....	31
Troubleshooting (Roller) .....	32
Troubleshooting (Engine).....	33–34

### **NOTICE**

Specifications and part numbers are subject to change without notice.

# SAFETY INFORMATION

Do not operate or service the equipment before reading the entire manual. Safety precautions should be followed at all times when operating this equipment. Failure to read and understand the safety messages and operating instructions could result in injury to yourself and others.



## SAFETY MESSAGES

The four safety messages shown below will inform you about potential hazards that could injure you or others. The safety messages specifically address the level of exposure to the operator and are preceded by one of four words: **DANGER**, **WARNING**, **CAUTION** or **NOTICE**.

## SAFETY SYMBOLS

**DANGER**

Indicates a hazardous situation which, if not avoided, **WILL** result in **DEATH** or **SERIOUS INJURY**.

**WARNING**

Indicates a hazardous situation which, if not avoided, **COULD** result in **DEATH** or **SERIOUS INJURY**.

**CAUTION**

Indicates a hazardous situation which, if not avoided, **COULD** result in **MINOR** or **MODERATE INJURY**.

**NOTICE**

Addresses practices not related to personal injury.

The following table shows the potential hazards associated with the operation of this equipment.

Symbol	Safety Hazard
	Lethal exhaust gas hazards
	Explosive fuel hazards
	Burn hazards
	Respiratory hazards
	Rotating parts hazards
	Pressurized fluid hazards
	Electric shock hazards
	Runover hazards

# SAFETY INFORMATION

## GENERAL SAFETY

### CAUTION

- **NEVER** operate this equipment without proper protective clothing, shatterproof glasses, respiratory protection, hearing protection, steel-toed boots and other protective devices required by the job or city and state regulations.



- **NEVER** operate this equipment when not feeling well due to fatigue, illness or when under medication. 
- **NEVER** operate this equipment under the influence of drugs or alcohol.



- **ALWAYS** check the equipment for loosened threads or bolts before starting.
- **DO NOT** use the equipment for any purpose other than its intended purposes or applications.
- **ALWAYS** clear the work area of any debris, tools, etc. that would constitute a hazard while the equipment is in operation.

### NOTICE

- This equipment should only be operated by trained and qualified personnel 18 years of age and older.
- Whenever necessary, replace nameplate, operation and safety decals when they become difficult read.
- Manufacturer does not assume responsibility for any accident due to equipment modifications. Unauthorized equipment modification will void all warranties.
- **NEVER** use accessories or attachments that are not recommended by Multiquip for this equipment. Damage to the equipment and/or injury to user may result.
- **ALWAYS** know the location of the nearest **fire extinguisher**. 
- **ALWAYS** know the location of the nearest **first aid kit**. 
- **ALWAYS** know the location of the nearest phone or **keep a phone on the job site**. Also, know the phone numbers of the nearest **ambulance, doctor** and **fire department**. This information will be invaluable in the case of an emergency.

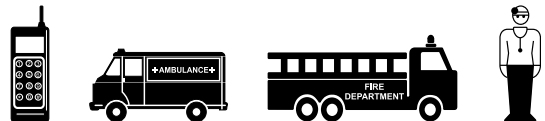

# SAFETY INFORMATION

## ROLLER SAFETY

### DANGER

- **NEVER** operate the equipment in an explosive atmosphere or near combustible materials. An explosion or fire could result causing severe bodily harm or even death.



### WARNING

- **NEVER** disconnect any **emergency or safety devices**. These devices are intended for operator safety. Disconnection of these devices can cause severe injury, bodily harm or even death. Disconnection of any of these devices will void all warranties.

### CAUTION

- **NEVER** lubricate components or attempt service on a running machine.
- Never leave the roller unattended with the engine running. Turn off engine.
- Use chock blocks when parking roller on a grade.
- Use extreme care when operating near obstructions, on slippery surfaces, grades, and slide slopes.
- When reversing, particularly on the edges and banks of ditches, as well as in front of obstacles, the operator must stay in a standing position at a safe distance from the machine.
- When operating near any house/building or pipelines, always check the effect of machine vibration. Stop work if necessary.
- **DO NOT** operate the roller with the covers open.
- **ALWAYS** keep the machine away from other personnel and obstacles. Always keep immediate area free of bystanders.

### NOTICE

- **ALWAYS** keep the machine in proper running condition.
- Fix damage to machine and replace any broken parts immediately.

- **DO NOT** use worn-out hoses or couplings. Inspect daily.
- **ALWAYS** store equipment properly when it is not being used. Equipment should be stored in a clean, dry location out of the reach of children and unauthorized personnel.

## ENGINE SAFETY

### DANGER

- The engine fuel exhaust gases contain poisonous carbon monoxide. This gas is colorless and odorless, and can cause death if inhaled.
- The engine of this equipment requires an adequate free flow of cooling air. **NEVER** operate this equipment in any enclosed or narrow area where free flow of the air is restricted. If the air flow is restricted it will cause injury to people and property and serious damage to the equipment or engine.



### WARNING

- **DO NOT** place hands or fingers inside engine compartment when engine is running.
- **NEVER** operate the engine with heat shields or guards removed.
- Keep fingers, hands hair and clothing away from all moving parts to prevent injury.
- **DO NOT** remove the engine oil drain plug while the engine is hot. Hot oil will gush out of the oil tank and severely scald any persons in the general area of the roller.



### CAUTION

- **NEVER** touch the hot exhaust manifold, muffler or cylinder. Allow these parts to cool before servicing equipment.
- Always turn the engine off before performing maintenance.



# SAFETY INFORMATION

## NOTICE

- **NEVER** run engine without an air filter or with a dirty air filter. Severe engine damage may occur. Service air filter frequently to prevent engine malfunction.
- **NEVER** tamper with the factory settings of the engine or engine governor. Damage to the engine or equipment can result if operating in speed ranges above the maximum allowable.
- **NEVER** tip the engine to extreme angles during lifting as it may cause oil to gravitate into the cylinder head, making the engine start difficult.



## FUEL SAFETY

### DANGER

- **DO NOT** add fuel to equipment if it is placed inside truck bed with plastic liner. Possibility exists of explosion or fire due to static electricity.

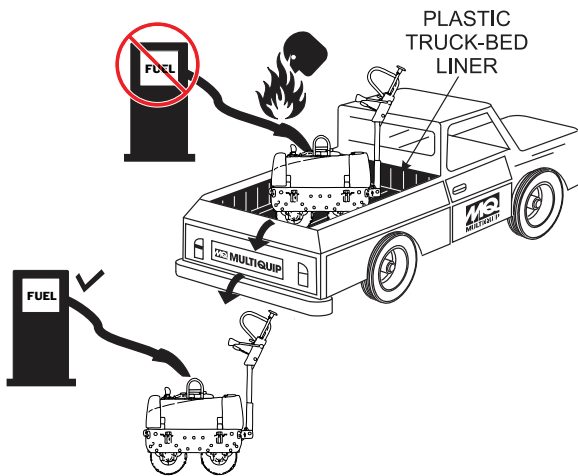

- **DO NOT** start the engine near spilled fuel or combustible fluids. Diesel fuel is extremely flammable and its vapors can cause an explosion if ignited.
- **ALWAYS** refuel in a well-ventilated area, away from sparks and open flames.
- **ALWAYS** use extreme caution when working with **flammable** liquids.
- **DO NOT** fill the fuel tank while the engine is running or hot.

- **DO NOT** overfill tank, since spilled fuel could ignite if it comes into contact with hot engine parts or sparks from the ignition system.
- Store fuel in appropriate containers, in well-ventilated areas and away from sparks and flames.
- **NEVER** use fuel as a cleaning agent.
- **DO NOT** smoke around or near the equipment. Fire or explosion could result from fuel vapors or if fuel is spilled on a hot engine.



## BATTERY SAFETY (ELECTRIC START ONLY)

### DANGER

- **DO NOT** drop the battery. There is a possibility that the battery will explode.
- **DO NOT** expose the battery to open flames, sparks, cigarettes, etc. The battery contains combustible gases and liquids. If these gases and liquids come into contact with a flame or spark, an explosion could occur.



### WARNING

- **ALWAYS** wear safety glasses when handling the battery to avoid eye irritation. The battery contains acids that can cause injury to the eyes and skin.
- Use well-insulated gloves when picking up the battery.
- **ALWAYS** keep the battery charged. If the battery is not charged, combustible gas will build up.
- **DO NOT** charge battery if frozen. Battery can explode. When frozen, warm the battery to at least 61°F (16°C).
- **ALWAYS** recharge the battery in a well-ventilated environment to avoid the risk of a dangerous concentration of combustible gases.
- If the battery liquid (dilute sulfuric acid) comes into contact with **clothing or skin**, rinse skin or clothing immediately with plenty of water.





# SAFETY INFORMATION

- If the battery liquid (dilute sulfuric acid) comes into contact with **eyes**, rinse eyes immediately with plenty of water and contact the nearest doctor or hospital to seek medical attention.

## CAUTION

- **ALWAYS** disconnect the **NEGATIVE battery terminal** before performing service on the equipment.
- **ALWAYS** keep battery cables in good working condition. Repair or replace all worn cables.

## TRANSPORTING SAFETY

## CAUTION

- **NEVER** allow any person or animal to stand underneath the equipment while lifting.

## NOTICE

- Before lifting, make sure that the equipment parts are not damaged and screws are not loose or missing.
- Use lifting equipment capable of lifting the weight of the roller.
- Always make sure crane or lifting device has been properly secured to the lifting bail (hook) of the equipment.
- **ALWAYS** shutdown engine before transporting.
- **NEVER** lift the equipment while the engine is running.
- Tighten fuel tank cap securely and close fuel cock to prevent fuel from spilling.
- Use adequate lifting cable (wire or rope) of sufficient strength.
- Use one point suspension hook and lift straight upwards with sufficient bearing capacity to prevent machine from tilting or slipping.
- **DO NOT** lift machine to unnecessary heights.
- **ALWAYS** make sure that roller is secured correctly when transporting on a trailer. Make sure all supports attaching the roller to the trailer are tight.

## ENVIRONMENTAL SAFETY

### NOTICE

- Dispose of hazardous waste properly. Examples of potentially hazardous waste are used motor oil, fuel and fuel filters. 
- **DO NOT** use food or plastic containers to dispose of hazardous waste.
- **DO NOT** pour waste, oil or fuel directly onto the ground, down a drain or into any water source.

## SPECIFICATIONS (ROLLER)

---

**Table 1. Specifications (Vibratory Roller)**

Dimensions (LxWxH)	105 x 27.2 x 46 in (2670 x 692 x 1060 mm)
Drum Diameter	16 in. (406 mm)
Drum Width	25.6 in. (650 mm)
Curb Clearance	9.4 in. (238 mm)
Side Overhang	.83 in. (21 mm)
Operating Weight (with water)	1530 lbs. (694 kg.)
Vibration Frequency	3,300 vpm
Centrifugal Force	5,283 lbs (23.5 kn)
Drive System	Hydraulic Motor
Vibration System	Frame
Vibration Method	Belt Drive
Vibrator Shaft	Twin
Gradeability	20 degrees
Working Speed	0 - 3 mph (0 - 4.8 kph)
Fuel Tank Capacity	1.88 gallons (7.1 liters)
Lubricating Oil	6.6 gallons (25 liters)
Water Tank Capacity	10.57 gallons (40 liters)

## SPECIFICATIONS (ENGINE)

<b>Table 2. Specifications (Engine)</b>				
Engine Make	HONDA			
Engine Model	GX390K1SM32	GX390U1SM32	GX390UT2SM32	GX390UT2SCM1
Engine Type	Air-cooled 4 stroke, Single Cylinder, OHV, Horizontal Shaft Gasoline Engine			
Cylinder Bore X Stroke	3.5 in. X 2.5 in. (88 mm x 64 mm.)			
Displacement	23.70 cu-in (389 cc))			
Net Power (In accordance with SAE J1349*)	11 H.P. (8.2 kW).			
Fuel Tank Capacity	1.61 gallons (6.1 liters)			
Fuel	Unleaded Automobile Gasoline			
Oil Capacity	1.2 quarts (1.1 liters)			
Oil Alert System	Yes			
Air Cleaner	Standard		Cyclone	
Speed Control Method	Centrifugal Fly-weight Type			
Starting Method	Electric/Recoil Start			
Dry Net Weight	69.4 lbs (35 Kg.)			
Dimensions (L x W x H)	15.0 x 17.7 X 17.4 in. (380 X 450 X 443 mm.)			
<p>*The power rating of the engine is the net power output tested on a production engine and measured in accordance with SAE J1349 at 3,600 rpm (net power) and at 2,500 rpm (max net torque). Mass production engines may vary from this value. Actual power output for the engine installed in the machine will vary depending on numerous factors, including the operating speed of the engine in application, environmental conditions, maintenance and other variables</p>				

# DIMENSIONS

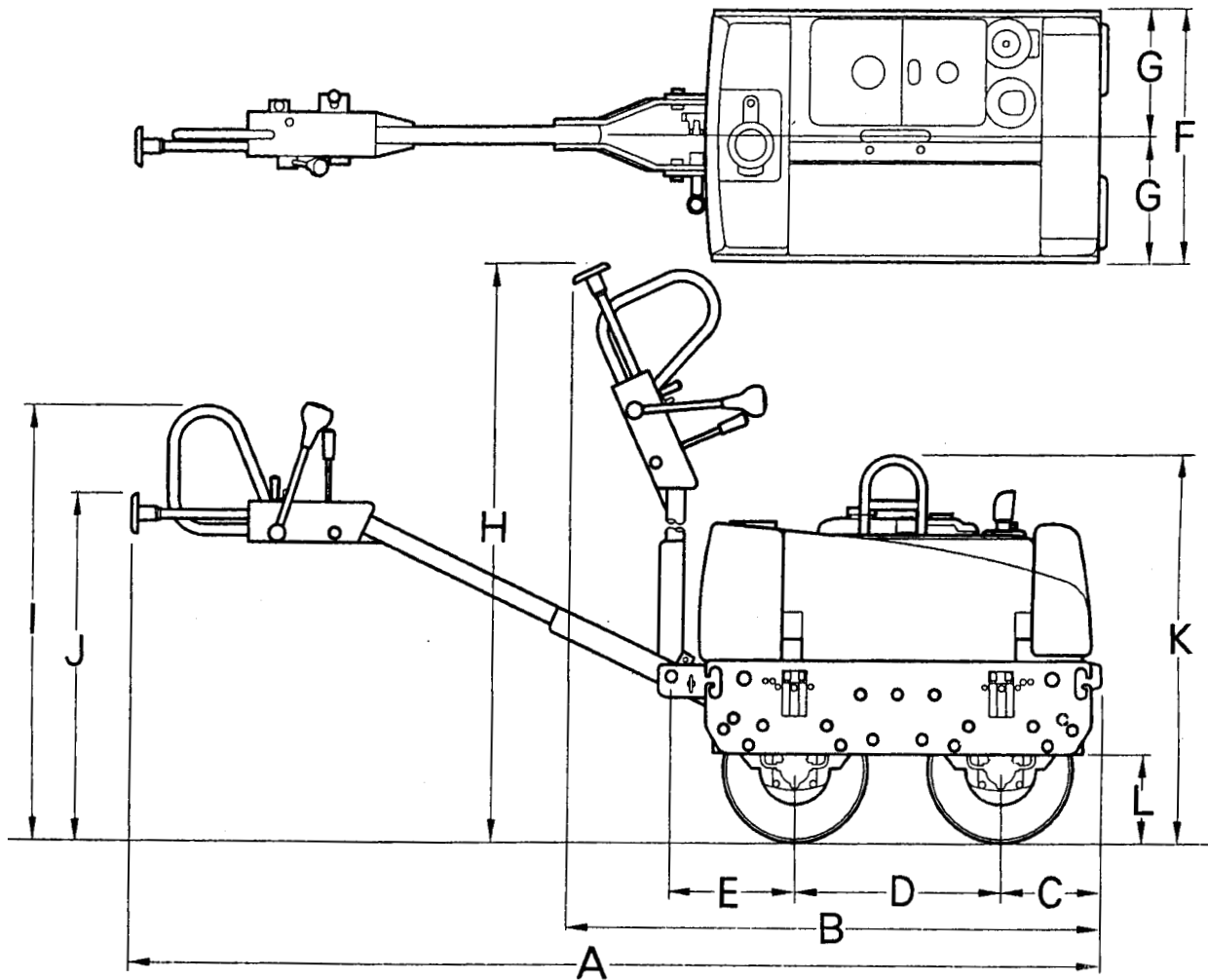

Figure 1. MRH800GS Dimensions

Table 3. Dimensions			
LENGTH	A	105 in.	2670 mm.
	B	58 in.	1470 mm.
	C	10 in.	255 mm.
	D	22.8 in.	580 mm.
	E	13.8 in.	350 mm.
WIDTH	F	27.2 in.	692 mm.
	G	13.6 in.	346 mm.
HEIGHT	H	78.3 in.	1990 mm.
	I	46.0 in.	1170 mm.
	J	37.4 in.	950 mm.
	K	44.1 in.	1120 mm.
	L	9.4 in.	238 mm.

The Mikasa Model MRH800GS is a powerful compacting tool capable of applying tremendous force in consecutive impacts to a soil surface. Applications include soil compacting for backfilling for gas pipelines, water pipelines and cable installation work.

The impact force of the MRH800GS levels and uniformly compacts voids between soil particles to increase dry density.

Features include:

- Hydraulic transmission to allow speed change without gear shifting.
- Deadman device which when pressed or hit will cause the travel lever to return to neutral position bringing the machine to a stop.
- A horn to warn of machine's approach.
- Non-corrosive water tank for the sprinkler system with a capacity of more than 10 gallons.
- Lifting hook to transport machine.
- Front bumper and working light.
- Narrow profile with less than one inch wall clearance. Narrower width allows access to tighter areas. No exposed hydraulic hoses.
- Oil bath lubricated bearings and external vibration for less servicing and more dependability.
- Front and rear drum scrapers.
- Drum sprinkler system controls located near the operator.
- Easy access to hydraulic components and hydraulic filter.

# ROLLER COMPONENTS

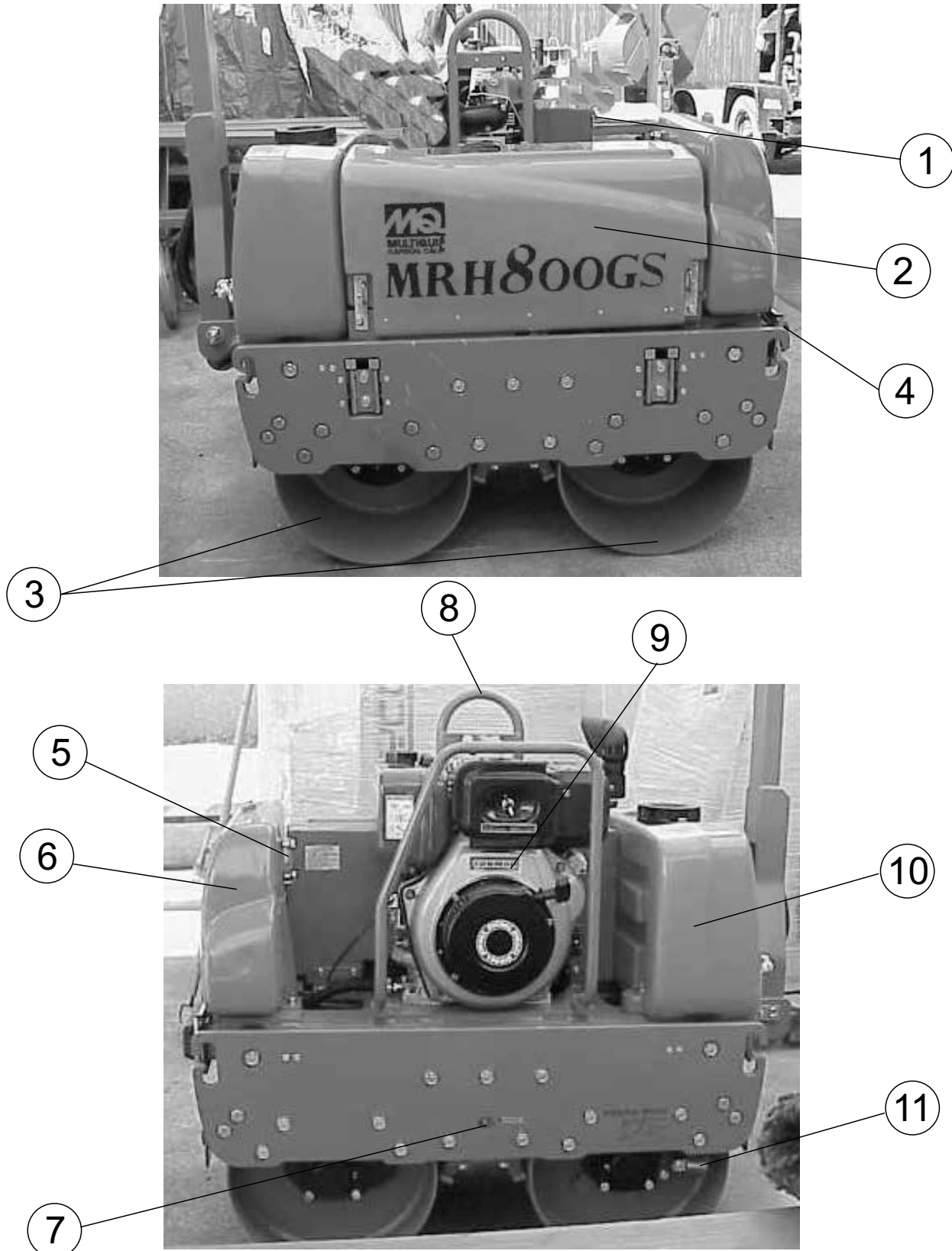

Figure 2. MRH800GS Components

## ROLLER COMPONENTS

---

Figure 2 illustrates the location of the major components for the MRH800GS Vibration Roller. The function of each component is described below:

1. **Fuel Tank/Cap** — Fill with diesel fuel. Fuel tank holds approximately 2 gallons (7.5 liters). DO NOT top off fuel. Wipe up any spilled fuel immediately.
2. **Center Cover** — When opened and supported by strut, provides access to oil pump and filter, battery, V-belt, and clutch box.
3. **Vibration Rollers** — 25-inch wide steel drums that provide compaction force in the compaction and patching of asphalt type surfaces.
4. **Front Headlights** — Activate using switch on control handle. Use to illuminate ground during nighttime or low-light operating conditions.
5. **Hydraulic Oil Gauge** — Indicates the hydraulic oil level.
6. **Oil Tank** — Fill with proper grade of hydraulic oil.
7. **Vibrator Oil Level Plug** — Remove to check vibrator oil level.
8. **Lifting Hook** — Used to lift the machine with crane or other lifting device.
9. **Engine** — This machine uses the Honda GX390 series gasoline engine. Refer to the engine Owner's Manual for more information.
10. **Water Tank** — Holds 10.57 gallons (40 liters) for the sprinkler system.
11. **Parking Brake** — Makes sure machine will not accidentally move when parked or not in use.

## ROLLER COMPONENTS (CONT'D.)

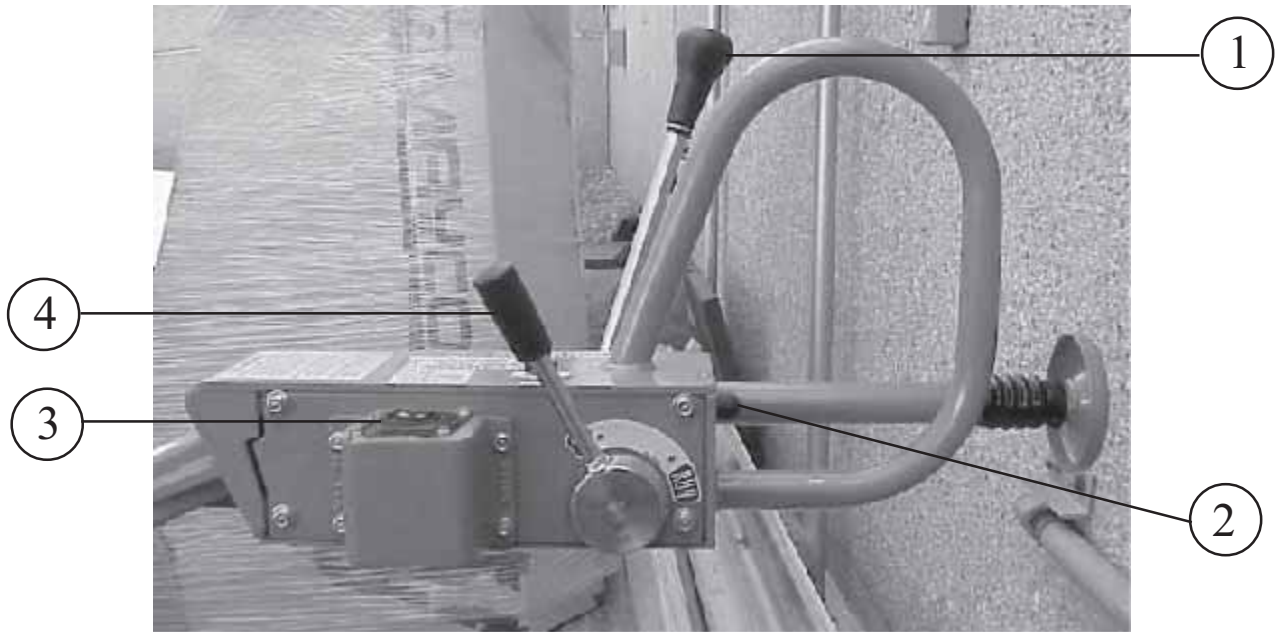

Figure 3. Handle Bar/Lever Components



## ROLLER COMPONENTS (CONT'D.)

---

### HANDLE BAR/LEVER COMPONENTS

Figure 3 illustrates the location of the major lever components on the handle bar of the machine. Each component is described below:

1. **Travel Lever** — Controls the direction of travel of the machine (forward and reverse).
2. **Horn Button** — When pressed, gives a warning sound of the machine approaching.
3. **Vibration Lever** — Turns vibration on and off.
4. **Throttle Lever** — Controls the start up of the machine.
5. **Dead-Man Device** — When pressed or hit while traveling in reverse, causes the travel lever to return to neutral position to stop the machine.
6. **Light ON/OFF Switch** — Turns headlight on and off.

# ENGINE COMPONENTS

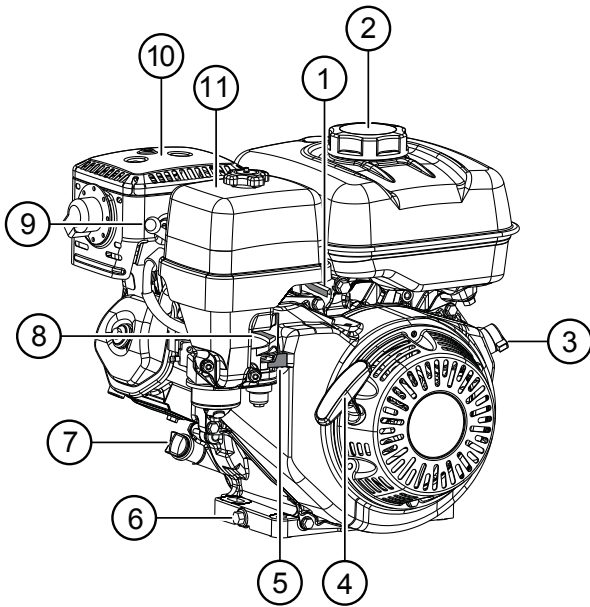

Figure 4. Engine Components

## INITIAL SERVICING

The engine (Figure 4) must be checked for proper lubrication and filled with fuel prior to operation. Refer to the manufacturer's engine manual for detailed operation and service instructions.

1. **Throttle Lever** — Adjusts engine RPM speed.
2. **Fuel Filler Cap/Fuel Tank** — Remove this cap to add unleaded gasoline to the fuel tank. Refer to Table 2 for fuel tank capacity. Make sure the cap is tightened securely. **DO NOT** overfill

### DANGER



Add fuel to the tank **only** when the engine is stopped and has had an opportunity to cool down. In the event of a fuel spill, **DO NOT** attempt to start the engine until all fuel residue has been completely wiped up and the area surrounding the engine is dry.

3. **Engine ON/OFF Switch** — **ON** position permits engine starting. **OFF** position stops engine operation.
4. **Recoil Starter** — Manual starting method. Pull the starter grip until resistance is felt, then pull briskly and smoothly to start the engine.
5. **Fuel Valve Lever** — Open to allow fuel to flow. Close to prevent fuel flow.
6. **Oil Drain Bolt** — Remove this bolt to drain oil from the engine crankcase.
7. **Oil Filler Cap/Dipstick** — Remove this cap to determine if engine oil is low. Add oil through this filler port as recommended in Table 2.
8. **Choke Lever** — Used in cold weather conditions or for the starting of a cold engine. The choke enriches the fuel mixture.
9. **Spark Plug** — Provides spark to the ignition system. Set the spark plug gap according to the engine manufacturer's instructions. Clean the spark plug once a week.
10. **Muffler** — Reduces noise and emissions. **NEVER** touch the muffler while it is **hot!**

### WARNING



Engine components can generate extreme heat. To prevent burns, **DO NOT** touch these areas while the engine is running or immediately after operating. **NEVER** operate the engine with the muffler removed.

11. **Air Cleaner** — Prevents dirt and other debris from entering the fuel system. Remove the wing nut on top of the air cleaner cover to gain access to the filter elements.

### NOTICE

Operating the engine without an air cleaner, with a damaged air cleaner, or with an air cleaner in need of replacement will allow dirt to enter the engine, causing rapid engine wear.

## BEFORE STARTING

1. Read safety information at the beginning of manual.
2. Remove dirt and dust, particularly in the engine cooling air inlet, carburetor and air cleaner.
3. Check the air filter for dirt and dust. If air filter is dirty, replace air filter with a new one.
4. Check carburetor for external dirt and dust. Clean with dry compressed air.
5. Check fastening nuts and bolts for tightness.
6. Understand the geographical features and regulations of the job site.

## ENGINE OIL CHECK

1. To check the engine oil level, place the machine on secure level ground with the engine stopped.
2. Remove the filler dipstick from the engine oil filler hole (Figure 5) and wipe clean.

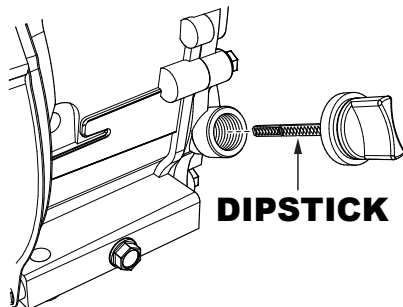

**Figure 5. Engine Oil Level**

3. Insert and remove the dipstick without screwing it into the filler neck. Check the oil level shown on the dipstick.
4. If the oil level is low, fill to the edge of the oil filler hole with the recommended oil type (Table 4). Maximum oil capacity is 1.16 quarts (1.1 liters).

**Table 4. Oil Type**

Season	Temperature	Oil Type
Summer	25°C or Higher	SAE 10W-30
Spring/Fall	25°C~10°C	SAE 10W-30/20
Winter	0°C or Lower	SAE 10W-10

## CHECKING THE HYDRAULIC SYSTEM

1. Check the oil tank level gauge (Figure 6). Oil level should be at the middle indication of the gauge or higher. Fill as required.

LEVELS SHOULD BE MIDDLE OF GAUGE OR HIGHER

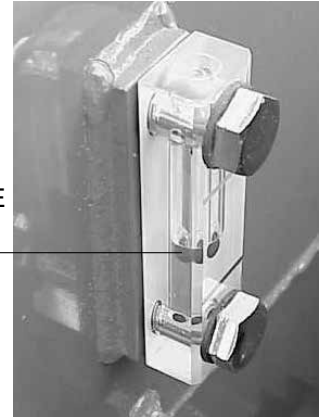

**Figure 6. Hydraulic System Oil Level Gauge**

2. Check the surroundings of the oil tank, hydraulic pump and motor for oil leakage.

## CHECKING THE V-BELT

**! DANGER**



**ALWAYS** keep hands and fingers away from pinch points. **DO NOT** allow anyone to reach in on dangerous sections of the machine to avoid any accidents.

1. Remove the 2 bolts, one on each side of the center cover, with a #13 socket wrench. Open the center cover of the machine and support it with the strut by inserting its end to the hole in the base (Figure 7).

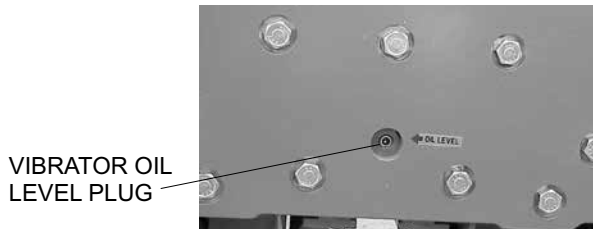

**Figure 7. Checking V-Belt Tension**

2. Check V-belt for proper tension. Insufficient tension causes weak vibration.

## CHECKING THE VIBRATOR OIL LEVEL

1. Check vibrator casing for any oil leakage.
2. If any leakage is noticed, remove the level plug on the side of the plate (Figure 8).



**Figure 8. Checking Vibrator Oil Level**

3. Check the oil level.

## FUEL CHECK

### DANGER



Motor fuel is highly flammable and can be dangerous if mishandled. **DO NOT** smoke while refueling. **DO NOT** attempt to refuel the pump if the engine is *hot or running*.

1. Remove the fuel cap located on top of the engine fuel tank.
2. Visually inspect to see if the fuel level is low. If fuel is low, replenish with unleaded gasoline using a strainer for filtration. **DO NOT** top-off fuel. Wipe up any spilled fuel immediately!

## CHECKING WATER TANK

Check the water tank to see if filled. Add water if necessary. The water tank has a capacity of approximately 10 gallons (40 liters). See Figure 9.



**Figure 9. Checking Water Tank**

### CAUTION

Be careful not to confuse the water tank with the oil tank.

## CHECKING LEVERS AND HORN

1. Check travel, vibration and throttle levers to make sure they are functioning properly (Figure 3).
2. With travel lever placed in reverse, push the deadman device and verify that the travel lever returns to the neutral position. The travel lever stays in the neutral position once the deadman device is released.
3. Press the horn and verify that it functions properly.

## CHECKING SCRAPERS

1. Check scrapers and make sure that they are not clogged with mud, bent or damaged (Figure 10).

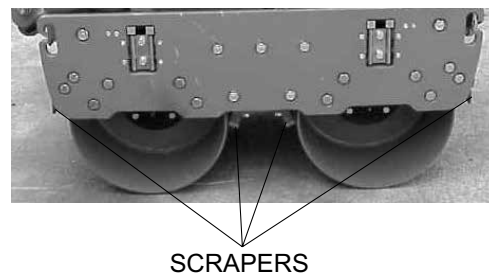

**Figure 10. Checking Scrapers**

2. Adjust clearance between drums and scrapers as necessary.

## CHECKING BOLTS, NUTS AND SCREWS

1. Check bolts, nuts and screws on various parts of the machine including the engine, for proper tightness.

## POSITIONING THE HANDLE BAR

1. Release the handle bar release pin (Figure 11) and position the handle bar to the lowered position before starting operation.



**Figure 11. Positioning the Handle Bar**

2. When machine is not in use, release the handle bar release pin and position the handle bar to the upright position.

# OPERATION

This section is intended to assist the operator with the initial startup of the unit. It is extremely important that this section be read carefully before using the roller in the field. **DO NOT** use your roller until this section is thoroughly understood.

## WARNING

Failure to understand the operation of the roller could result in severe damage to the roller or personal injury..

## CAUTION



**NEVER** operate the roller in a confined area or enclosed area structure that does not provide ample free flow of air.

## ELECTRIC START

On the control handle:

- a. Move the throttle lever to the **RUN** position.
  - b. Move the travel lever to the **NEUTRAL** position.
  - c. Move the vibration lever to the **OFF** position.
1. Move the fuel shut-off lever (Figure 12) to the **ON** position.

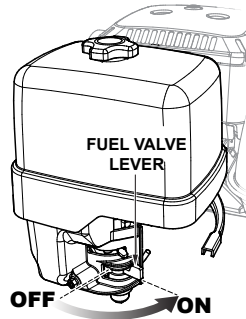

Figure 12. Fuel Shut-Off Lever

2. To start a cold engine, move the choke lever (Figure 13) to the **CLOSED** position.

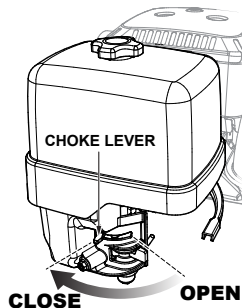

Figure 13. Choke Lever

3. Move the throttle lever (Figure 14) away from the **SLOW** position, about 1/3 of the way toward the **FAST** position.

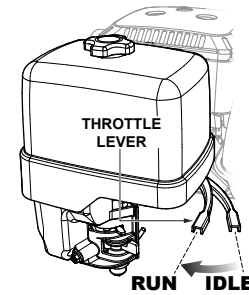

Figure 14. Throttle Lever

4. Turn the ignition switch on the engine to the **START** position (Figure 15). Release the key when engine starts and key will return to the **ON** position.

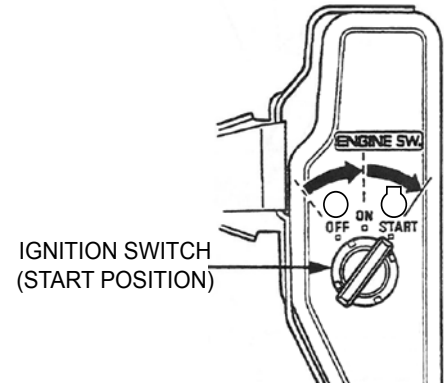

Figure 15. Ignition Switch (START)

## RECOIL START

1. Perform steps 1 to 3 in Electric Start section.
2. Turn the ignition switch on the engine to the **ON** position (Figure 16).

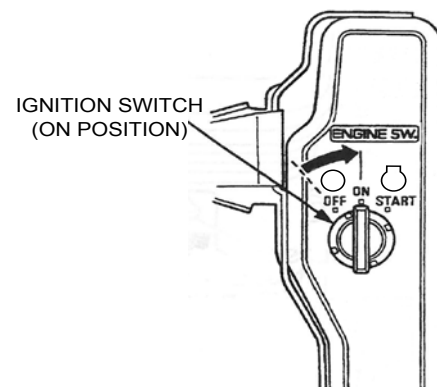
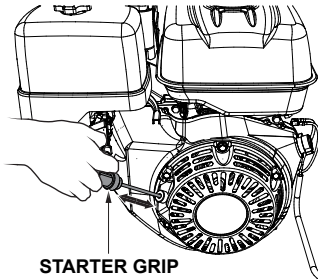

Figure 16. Ignition Switch (ON)

3. Grasp the starter grip and slowly pull it out (Figure 17). The resistance becomes the hardest at a certain position, corresponding to the compression point. Pull the starter grip briskly and smoothly for starting.



**Figure 17. Starter Grip**

## TRAVELING

1. Before starting to travel, make sure to release parking brake located on the left side of the rear roller. If the parking brake lever is tight, moving the roller back and forth will make it easier (Figure 18).



**PARKING BRAKE  
(RELEASED  
POSITION)**

**Figure 18. Parking Brake**

2. With the throttle lever in the **RUN** position, increase the engine rotation.
3. Push the travel lever forward slightly. This will cause the roller to travel forward at slow speed.
4. To increase the travel speed, push the travel lever further.
5. Travel speed can be varied between 0 and 3 km/h (both forward and reverse).
6. Push the travel lever backward to go in the reverse direction.

## **CAUTION**

Do not reduce speed during work. When shifting travel lever from forward to reverse, be sure to stop the lever at the neutral position first before moving the lever to the opposite direction. Do not shift the lever from forward to reverse (or from reverse to forward) in one motion.

## **CAUTION**

After test travel, shut down engine and check for any problems including oil leakage. If any trouble is found, correct the problem before attempting to operate the roller again.

## VIBRATING

1. Shift the vibration lever away from its off position. The vibration lever will automatically spring forward and the roller will start vibrating (Figure 19).



**VIBRATION LEVER  
(OFF POSITION)**

**Figure 19. Vibration Lever (Off Position)**

## **CAUTION**

Using vibration with clutch slipping causes the clutch to burn. Also, vibration should not be used over completely compacted area, paved road surface or with stationary roller.

## WATERING

2. For watering work, turn the water cocks clockwise, at the rear of the machine, to start sprinkling (Figure 20).

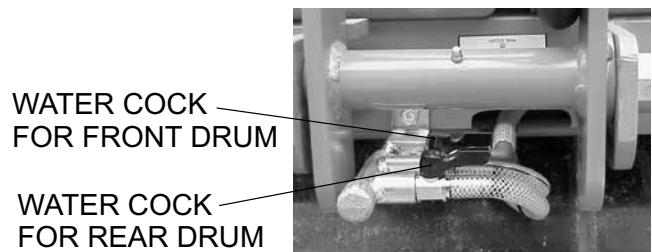

**Figure 20. Water Cocks**

## SAFETY FEATURES

A horn is provided to warn of approach. The deadman device prevents accidental traveling in reverse. It automatically makes the travel lever return to the neutral position by stopping the machine when an object comes in contact with the deadman device.

## STOPPING

1. With the travel lever in the neutral position and the vibration lever in the off position, return the throttle lever to the **START** position. Allow the machine to cool down for 3 to 5 minutes.
2. Push the throttle lever forward to stop the engine. In a motor start, return the key switch to the **STOP** position as soon as the engine stops.

### **CAUTION**

Neglecting to return the key switch to the STOP position will cause the battery to discharge making start up impossible the next time.

3. After the engine stops, close the fuel cock.
4. Lock the parking brake by pulling the brake lever and rotating it 90° clockwise.

### **NOTICE**

Parking brake system should always be kept clean to avoid mud deposits.

## UNLOADING

1. If you need to move the roller by pushing it manually once the engine is stopped, loosen bolt of bypass valve on oil pump by one rotation counterclockwise. This will cause the hydraulic brake to disengage and allow the roller to be moved more easily (Figure 21).

Bypass  
Valve  
Bolt

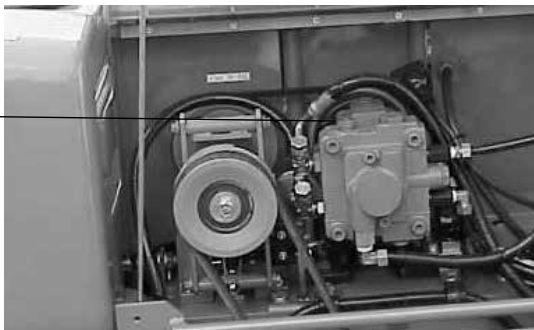

Figure 21. Location of Bypass Valve Bolt

2. After moving, tighten the bolt again. Tightening torque is 55 to 70 kgf-cm.

### **CAUTION**

**NEVER** tow roller with any type of vehicle. Doing so will damage the hydraulic system.

Never perform unloading procedure on a slope. This may cause the roller to roll down if parking brake or blocking is deficient.

## LIFTING

1. Use a crane or lift to load and unload the machine. A skilled crane operator is required to perform the job.
2. When lifting the machine, check for any damaged or loose bolts, lifting hooks and shock mounts.
3. Check any damaged or loose bolts in the guard frame to avoid machine sliding off.
4. Make sure that the machine is shut off before machine is lifted.
5. Use reliable cable for lifting.
6. Always lift the machine vertically and keep the machine away from workers and animals.
7. Do not lift the machine higher than the required height.

## TRANSPORTING

1. Always make sure that the machine is shut off while being transported.
2. Check that the fuel cap is properly closed and tightened.
3. When traveling long distances or on rugged terrain, drain the fuel of the machine before transporting.
4. Tie down the machine securely on the transportation so that it will not move or topple over.

## CAUTION

Inspection and other services should always be carried out on hard and level ground with the engine shutdown.

## INSPECTION AND MAINTENANCE SERVICE TABLES

To make sure your vibratory roller is always in good working condition before using, carry out the maintenance inspection procedures.

**Table 5. Machine Inspection**

ITEM	HOURS OF OPERATION
Loose or Missing Screws	Every 8 hours (every day)
Damaged Parts	Every 8 hours (every day)
Function of Controlling System Part	Every 8 hours (every day)
Hydraulic System Leak	Every 100 hours
Vibrator Oil Check	Every 100 hours
Vibrator Oil Replacement	Every 300 hours
Hydraulic Oil Check	Every 100 hours
Hydraulic Oil Replacement	First after 200 hours, then every 1,000 hours
V-belt (clutch) Check	Every 200 hours

## NOTICE

These inspection intervals are for operation under normal conditions. Adjust your inspection intervals based on the number of hours the roller is in use, and your particular working conditions.

## NOTICE

Fuel piping and connections should be replaced every 2 years.

**Table 6. Engine Check**

ITEM	HOURS OF OPERATION
Oil or Fuel Leak	Every 8 hours (every day)
Tightness of Fastening Threads	Every 8 hours (every day)
Engine Oil Check and Replenishment	Every 8 hours (every day) (Replenish to specified maximum level)
Engine Oil Replacement	After first 25 hours then every 50 to 100 hours
Air Filter Cleaning	Every 100 hours

## DAILY SERVICE

1. Check for leakage of fuel or oil.
2. Check for loose screws including tightness. See Table 7 below (tightening torque ) for retightening:

**Table 7. Tightening Torque (in. kg/cm) Diameter**

Material	6mm	8mm	10mm	12mm	14mm	16mm	18mm	20mm
4T	70	150	300	500	750	1,100	1,400	2,000
6-8T	100	250	500	800	1,300	2,000	2,700	3,800
11T	150	400	800	1,200	2,000	2,900	4,200	5,600
*	100	300~ 350	650 ~ 700					

3. Remove soil and clean the bottom of roller.
4. Check hydraulic pump, piping and hose for any leakage. A loosened hydraulic hose can be a cause for leakage.
5. Check hydraulic hose connections with wrench applied for tightness.
6. Check engine oil.



## SPARK PLUG

1. Remove and clean the spark plug (Figure 22).
2. Adjust the spark gap to 0.024 ~0.028 inch (0.6~0.7 mm). This unit has electronic ignition, which requires no adjustments.

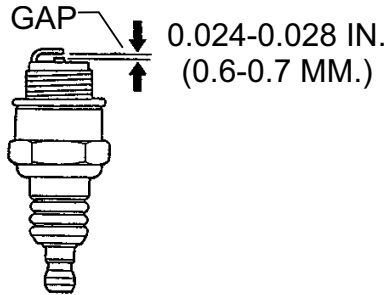

**Figure 22. Spark Plug Gap**

## ENGINE OIL

3. Drain the engine oil when the oil is warm as shown in Figure 23.
4. Remove the oil drain bolt and sealing washer and allow the oil to drain into a suitable container.
5. Replace engine oil with recommended type oil as listed in Table 4. Engine oil capacity is 1.16 quarts (1.1 liters). **DO NOT** overfill.
6. Install drain bolt with sealing washer and tighten securely.

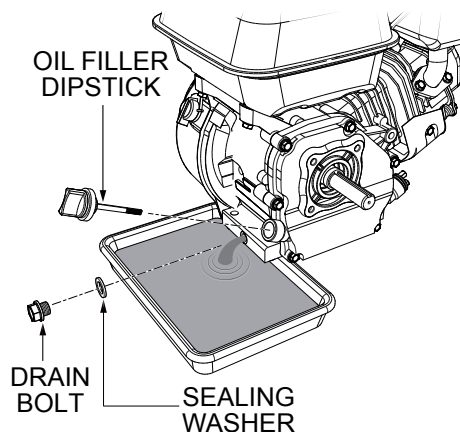

**Figure 23. Engine Oil (Draining)**

## STANDARD DUAL FILTER ELEMENT

The Honda GX390K1SM32, GX390U1SM32 and GX390UT2SM32 engines are equipped with a replaceable, high-density paper air cleaner element. See (Figure 24) for air cleaner components

1. Remove the air cleaner cover and foam filter element as shown in Figure 24.
2. Tap the paper filter element (Figure 24) several times on a hard surface to remove dirt, or blow compressed air [not exceeding 30 psi (207 kPa, 2.1 kgf/cm<sup>2</sup>)] through the filter element from the air cleaner case side. **NEVER** brush off dirt. Brushing will force dirt into the fibers. Replace the paper filter element if it is excessively dirty.
3. Clean foam element in warm, soapy water or nonflammable solvent. Rinse and dry thoroughly. Dip the element in clean engine oil and completely squeeze out the excess oil from the element before installing.

**! DANGER**

**DO NOT** use gasoline as a cleaning solvent to avoid creating the risk of fire or an explosion.

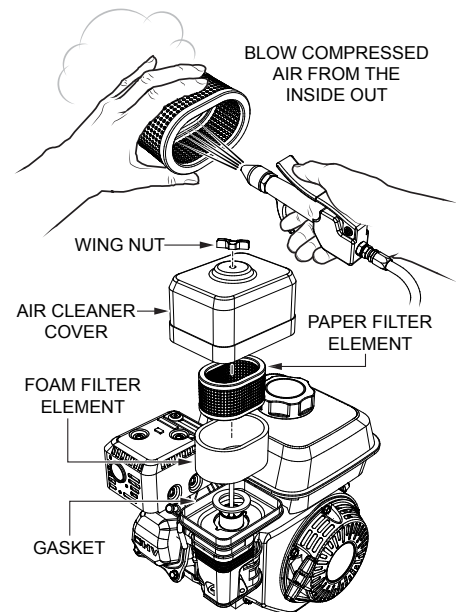
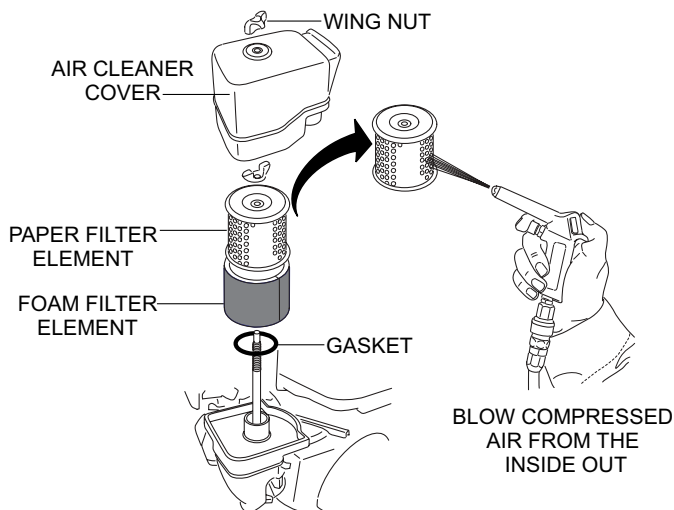

**Figure 24. Engine Air Cleaner (Standard)**

## CYCLONE DUAL FILTER ELEMENT

The Honda GX390UT2SCM1 engine is equipped with a replaceable, high-density paper air cleaner element. See (Figure 25) for air cleaner components.

1. Follow steps 1 through 3 as outlined in the "Dual Filter Element" section.



**Figure 25. Engine Air Filter (Cyclone)**

2. Blow compressed air through the air cleaner cover as shown in Figure 26. Clean inside of air filter cover with warm, soapy water or nonflammable solvent. Rinse and dry thoroughly.

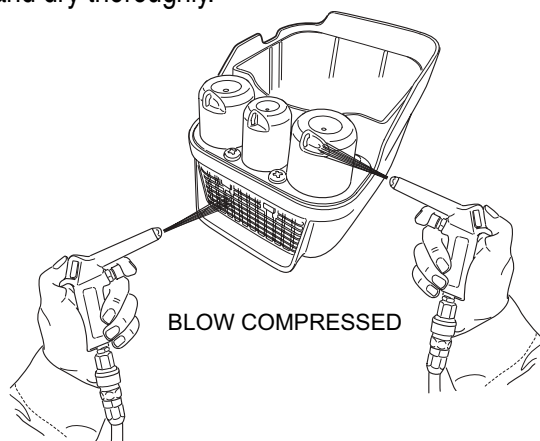

**Figure 26. Engine Air Filter Cover**

## ROLLER INSPECTION AND ADJUSTMENT

1. Refer to Table 8 for oil and grease requirements.
2. Check oil tank level daily.
3. Check the machine for oil leak and proper function of lever, cables and links daily.

## MACHINE MAINTENANCE

1. At the end of each day's operation, wash down dust and dirt off the machine. Clean area around drums and scrapers making sure all mud is removed.
2. Drain water tank completely.
3. Cover the machine to prevent dust and store in dry place away from sun exposure.

## LONG TERM STORAGE

1. Conduct thorough lubrication and oil change.
2. Disconnect battery terminals and dismount battery from machine. Store battery.
3. If there's a possibility that ambient temperature will drop below freezing point, add antifreeze agent to coolant.
4. Cover the inlet and outlet of air cleaner and muffler securely.
5. Store machine indoors. Do not leave outdoors.
6. Refer to Table 8 for lubrication necessary for the machine.

## BATTERY MAINTENANCE

### NOTICE

Read and understand the battery safety information in the front of this manual before performing maintenance on the battery.

1. Use a flashlight to check battery electrolyte level. Always check that the engine is stopped.
2. If a battery has not been used for some time, reduce the charge level initially to protect each plate inside the battery.
3. Check the battery terminals periodically to ensure that they are in good condition.

4. Use a wire brush or sand paper to clean the battery terminals.
  5. Check battery for cracks or any other damage. If white pattern appears inside the battery or paste has accumulated at the bottom, replace the battery.
  6. Measure the specific gravity of electrolyte:
    - completely charged: 1.270 - 1.290
    - needs charging: 1.260 or lower.
  7. If the machine will not be in operation for a long period of time, charge the battery sufficiently, tighten all caps correctly, store in cool dry place and check the battery charge level every month to maintain the performance of the battery.
4. When installing cable, connect the ground side (normally negative) last.
  5. With M8 bolt tightened, start engine and check the neutral for forward and reverse. If still displaced, repeat the procedure.
  6. If neutral position of forward/reverse lever has been displaced, use the turn buckle located on the oil pump side of forward/reverse cable.

## BATTERY CABLE CONNECTION

1. When removing cable, disconnect the ground side (normally negative) first (Figure 27).



**Figure 27. Battery Connection**

## FORWARD AND REVERSE TRAVEL ADJUSTMENT

2. If neutral position for forward and reverse travel has been displaced, conduct the neutral adjustment.
3. If roller travels forward with the ball of ball plunger remaining in V slot of the guide, loosen M8 bolt and slide the slide plate slightly toward the engine. If the roller travels backward, slide the plate towards side plate (Figure 28).

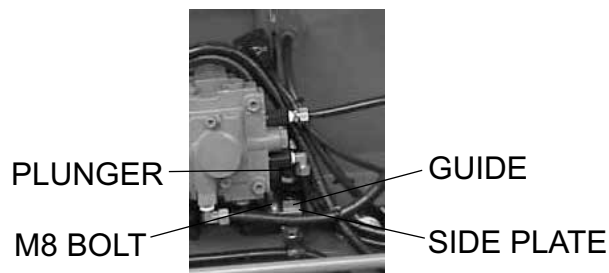

**Figure 28. Adjustment of Neutral Position**

## VIBRATION CLUTCH ADJUSTMENT

1. Move vibration lever to the OFF position.
2. Loosen the front and rear nuts at the end of vibration clutch cable (Figure 29).

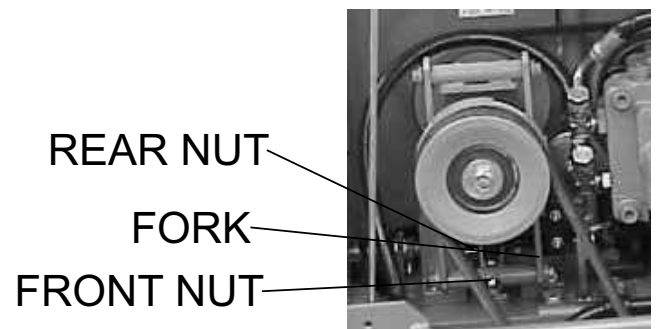

**Figure 29. Vibration Clutch Adjustment**

3. Turn in the nut on the front side again and at the position that release fork starts to move, turn in the nut by one or two threads. Lock it at this position together with the rear nut.

## CAUTION

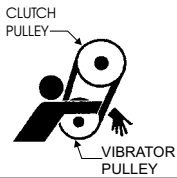

**NEVER** attempt to check the V-belt with the engine running. Severe injury can occur if your hand gets caught between the V-belt and the clutch. Always use safety gloves.

## CAUTION

Excessive turning of front nut may cause the sliding engagement of clutch to take place or no vibration takes place even when vibration lever is engaged.

On the other hand, insufficient turn may cause sliding engagement of clutch even when the vibration lever is placed in the **OFF** position or for vibration to remain engaged.

## HYDRAULIC SYSTEM INSPECTION AND SERVICE

1. Check motor and pump for any damage.
2. Check hoses and pipes for proper tightness and make sure there are no leaks.
3. Check nylon tubes for hydraulic oil intake and drain. Retighten brass nut if loose and if a leak is detected. If leak continues after retightening, replace nylon tube, nut and sleeve.
4. Check oil tank for proper oil level using the hydraulic system oil level gauge (See Figure 6). Make sure hydraulic oil has not whitened or emulsified. Whitish color means aeration in pump. Retighten pipe and correct level of oil. Emulsification means water in the hydraulic oil. Replace the oil.

**Table 8. Lubrication Chart**

<b>ITEM</b>	<b>MAINTENANCE NEEDED</b>	<b>FREQUENCY</b>	<b>TYPE</b>
Vibrator Oil	Replace Oil	Every 300 Hours of Operation	SAE10W30 (1.5 liters)
Engine Oil	Replace Oil	Initially - After 10 to 20 Hours of Operation Thereafter - Every 50 to 100 Hours of Operation	SAE#30 or SAE10W30 (Spring - Summer) SAE#20 or SAE10W30 (Fall - Winter) SAE10W30 (Extremely Cold Region)
Hydraulic Oil	Replace Oil	Every 1000 to 1500 Hours of Operation	Viscosity: ISO VG32 equivalent - for cold region ISO VG46 or 56 equivalent - for warm region Shipped from factory with Shell Tellus 46 (25 liters)
Travel Lever, Vibration Lever, Throttle Lever	Add Lubrication Oil to Sliding Parts	Every 50 Hours of Operation	Lubrication Oil
Deadman Device	Lubricate Grease Fitting	Every 50 Hours of Operation	Grease
Handle Bar Release Pin	Lubricate Grease Fitting	Every 50 Hours of Operation	Grease
Bearing Cover	Lubricate Grease Fitting	Every 50 Hours of Operation	Grease
Clutch Box	Lubricate Grease Fitting	Every 50 Hours of Operation	Grease
Travel Lever	Lubricate Sliding Parts	Every 50 Hours of Operation	Grease
Oil Filter	Replace Oil Filter	Initially - After 25 Hours of Operation Thereafter - Every 500 Hours of Operation	Mikasa Genuine 10 micron Filter Paper

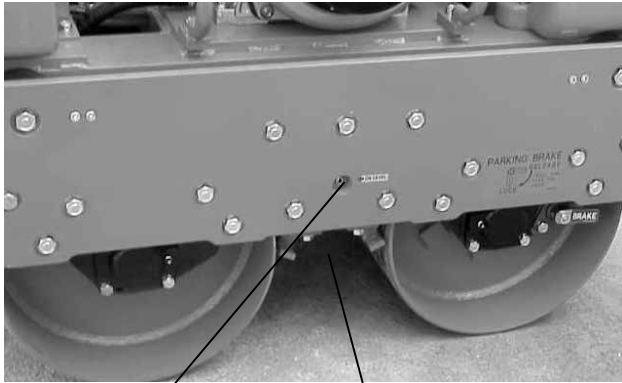

VIBRATOR OIL  
LEVEL PLUG

VIBRATOR OIL  
DRAIN PLUG

**Figure 30. Vibrator Oil Maintenance**

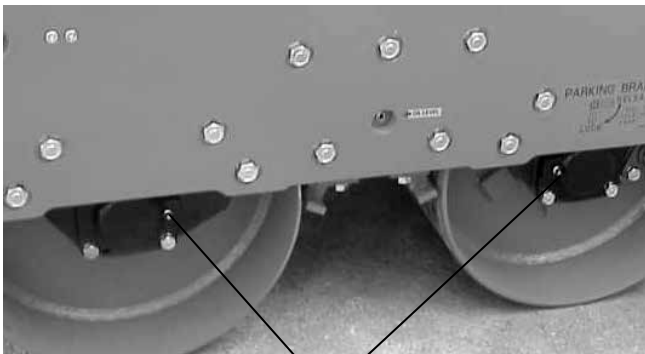

BEARING COVER  
GREASE FITTING



BEARING COVER  
GREASE FITTING

**Figure 31. Bearing Cover Maintenance**



HANDLE BAR RELEASE  
PIN GREASE FITTING

**Figure 32. Handle Bar Maintenance**

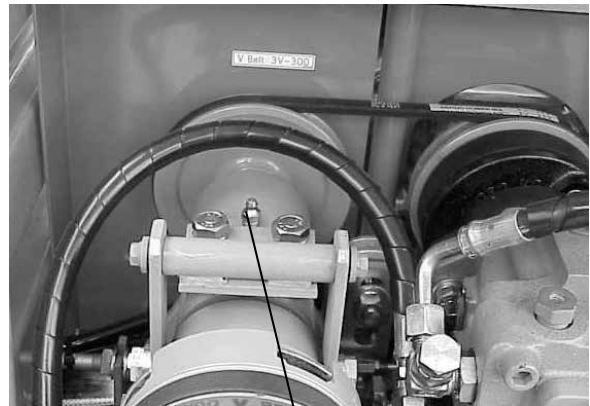

CLUTCH BOX  
GREASE FITTING

**Figure 33. Clutch Box Maintenance**



HYDRAULIC OIL FILTER

**Figure 34. Hydraulic Oil Filter Location**

# ELECTROMAGNETIC CLUTCH

---

## ELECTROMAGNETIC CLUTCH FOR VIBRATION SYSTEM

When the contact area of electromagnetic clutch (Table 9) is worn, it makes the gap slightly bigger between them. If the gap is over 0.028 in (0.7 mm), improper actuation or absorption can occur. Replace electromagnetic clutch at this point.

<b>Table 9. Specifications for Electromagnetic Clutch for Vibration System</b>	
Dead Worn Torque	25 Nm (2.5 kgf-m)
Rated Voltage	12V DC
Coil Resistance at 68 °F (20 °C)	6.6 ohms
Limited Gap	0.028 in (0.7 mm)

In case of over amperage, the fuse (5A) which is built in wire harness, will cut the line automatically. This function does not affect travelling of the roller, at which the engine starts and runs at 2,500 rpm. If there is no vibration, replace the fuse.

# TROUBLESHOOTING

<b>Troubleshooting - Roller</b>		
<b>SYMPTOM</b>	<b>POSSIBLE PROBLEM</b>	<b>SOLUTION</b>
Unit does not travel.	Parking brake still engaged?	Release parking brake lever.
Unit does not travel or travel is not smooth.	Defective centrifugal clutch?	Repair or replace clutch.
	Damaged rubber coupling and flange?	Replace rubber coupling and flange.
	Defective travel cable and link?	Repair or replace travel cable and link.
	Damaged scraper or too much mud in scraper?	Replace or repair scraper.
	Damaged or clogged oil filter?	Replace filter.
	Damaged or leaking hydraulic pipe?	Repair or replace parts.
	Low oil level or contaminated oil?	Replenish or replace oil.
	Damaged or leaking hydraulic pump?	Repair or replace hydraulic pump.
	Damaged or leaking hydraulic motor?	Repair or replace hydraulic motor.
	Damaged drum gear and bearing?	Repair parts.
Bad drum rotation?	Repair or replace drum.	
Unit does not vibrate or has weak vibration.	Defective centrifugal clutch?	Repair or replace clutch.
	Damaged or slipping V-belt?	Replace V-belt or adjust tension.
	Damaged vibration cable and linkage?	Replace or repair vibration cable and linkage.
	Damaged vibration clutch?	Adjust or replace clutch.
	Defective clutch vibrator pulley V-belt?	Replace V-belt.
	Vibrator does not turn smoothly with hand?	Check and repair vibrator. Check if oil level is not excessively high.



# TROUBLESHOOTING

<b>Troubleshooting (Engine)</b>		
<b>Symptom</b>	<b>Possible Problem</b>	<b>Solution</b>
Difficult to start, fuel is available, but no spark at spark plug.	Spark plug bridging?	Check gap, insulation or replace spark plug.
	Carbon deposit on spark plug?	Clean or replace spark plug.
	Short circuit due to deficient spark plug insulation?	Check spark plug insulation, replace if worn.
	Improper spark plug gap?	Set to proper gap.
	Spark plug is red?	Check transistor ignition unit.
	Spark plug is bluish white?	If insufficient compression, repair or replace engine. If injected air leaking, correct leak. If carburetor jets clogged, clean carburetor.
	No spark present at tip of spark plug?	Check if transistor ignition unit is broken, and replace defective unit. Check if voltage cord cracked or broken and replace. Check if spark plug is fouled and replace.
	No oil?	Add oil as required.
Difficult to start, fuel is available, and spark is present at the spark plug.	Oil pressure alarm lamp blinks upon starting? (if applicable)	Check automatic shutdown circuit, oil sensor. (if applicable)
	ON/OFF switch is shorted?	Check switch wiring, replace switch.
	Ignition coil defective?	Replace ignition coil.
	Improper spark gap, points dirty?	Set correct spark gap and clean points.
	Condenser insulation worn or short circuiting?	Replace condenser.
Difficult to start, fuel is available, spark is present and compression is normal.	Spark plug wire broken or short circuiting?	Replace defective spark plug wiring.
	Wrong fuel type?	Flush fuel system, replace with correct type of fuel.
	Water or dust in fuel system?	Flush fuel system.
	Air cleaner dirty?	Clean or replace air cleaner.
Difficult to start, fuel is available, spark is present and compression is low.	Choke open?	Close choke.
	Suction/exhaust valve stuck or protruded?	Reseat valves.
	Piston ring and/or cylinder worn?	Replace piston rings and/or piston.
	Cylinder head and/or spark plug not tightened properly?	Torque cylinder head bolts and spark plug.
No fuel present at carburetor.	Head gasket and/or spark plug gasket damaged?	Replace head and spark plug gaskets.
	No fuel in fuel tank?	Fill with correct type of fuel.
	Fuel cock does not open properly?	Apply lubricant to loosen fuel cock lever, replace if necessary.
	Fuel filter/lines clogged?	Replace fuel filter.
	Fuel tank cap breather hole clogged?	Clean or replace fuel tank cap.
	Air in fuel line?	Bleed fuel line.

# TROUBLESHOOTING

<b>Troubleshooting (Engine) - continued</b>		
<b>Symptom</b>	<b>Possible Problem</b>	<b>Solution</b>
Weak in power, compression is proper and does not misfire.	Air cleaner dirty?	Clean or replace air cleaner.
	Improper level in carburetor?	Check float adjustment, rebuild carburetor.
	Defective spark plug?	Clean or replace spark plug.
	Improper spark plug?	Set to proper gap.
Weak in power, compression is proper but misfires.	Water in fuel system?	Flush fuel system and replace with correct type of fuel.
	Dirty spark plug?	Clean or replace spark plug.
	Ignition coil defective?	Replace ignition coil.
Engine overheats.	Wrong type of fuel?	Replace with correct type of fuel.
	Cooling fins dirty?	Clean cooling fins.
	Intake air restricted?	Clear intake of dirt and debris. Replace air cleaner elements as necessary.
	Oil level too low or too high?	Adjust oil to proper level.
Rotational speed fluctuates.	Governor adjusted incorrectly?	Adjust governor.
	Governor spring defective?	Replace governor spring.
	Fuel flow restricted?	Check entire fuel system for leaks or clogs.
Recoil starter malfunctions. (if applicable)	Recoil mechanism clogged with dust and dirt?	Clean recoil assembly with soap and water.
	Spiral spring loose?	Replace spiral spring.
Starter malfunctions.	Loose, damaged wiring?	Ensure tight, clean connections on battery and starter.
	Battery insufficiently charged?	Recharge or replace battery.
	Starter damaged or internally shorted?	Replace starter.
Burns too much fuel.	Over-accumulation of exhaust products?	Check and clean valves. Check muffler and replace if necessary.
	Wrong spark plug?	Replace spark plug with manufacturer's suggested type.
Exhaust color is continuously white.	Lubricating oil is wrong viscosity?	Replace lubricating oil with correct viscosity.
	Worn rings?	Replace rings.
Exhaust color is continuously black.	Air cleaner clogged?	Clean or replace air cleaner.
	Choke valve set to incorrect position?	Adjust choke valve to correct position.
	Carburetor defective, seal on carburetor broken?	Replace carburetor or seal.
	Poor carburetor adjustment, engine runs too rich?	Adjust carburetor.
Will not start, no power with key ON. (if applicable)	ON/OFF device not activated ON?	Turn on ON/OFF device.
	Battery disconnected or discharged?	Check cable connections. Charge or replace battery.
	Ignition switch/wiring defective?	Replace ignition switch. Check wiring.



# OPERATION MANUAL

## HERE'S HOW TO GET HELP

PLEASE HAVE THE MODEL AND SERIAL  
NUMBER ON-HAND WHEN CALLING

### UNITED STATES

#### ***Multiquip Inc.***

(310) 537- 3700  
6141 Katella Avenue Suite 200  
Cypress, CA 90630  
E-MAIL: [mq@multiquip.com](mailto:mq@multiquip.com)  
WEBSITE: [www.multiquip.com](http://www.multiquip.com)

---

### CANADA

#### ***Multiquip***

(450) 625-2244  
4110 Industriel Boul.  
Laval, Quebec, Canada H7L 6V3  
E-MAIL: [infocanada@multiquip.com](mailto:infocanada@multiquip.com)

### UNITED KINGDOM

#### ***Multiquip (UK) Limited Head Office***

0161 339 2223  
Unit 2, Northpoint Industrial Estate,  
Globe Lane,  
Dukinfield, Cheshire SK16 4UJ  
E-MAIL: [sales@multiquip.co.uk](mailto:sales@multiquip.co.uk)

© COPYRIGHT 2020, MULTIQUIP INC.

Multiquip Inc, the MQ logo are registered trademarks of Multiquip Inc. and may not be used, reproduced, or altered without written permission. All other trademarks are the property of their respective owners and used with permission.

This manual MUST accompany the equipment at all times. This manual is considered a permanent part of the equipment and should remain with the unit if resold.

The information and specifications included in this publication were in effect at the time of approval for printing. Illustrations, descriptions, references and technical data contained in this manual are for guidance only and may not be considered as binding. Multiquip Inc. reserves the right to discontinue or change specifications, design or the information published in this publication at any time without notice and without incurring any obligations.

