



# MT-55F Tamping Rammer

## Starting Instructions

The following instructions are intended to assist the user in starting the MT-55F Tamping Rammer. Please read the entire instructions before starting.

### Rammer Gearbox and Spring Cylinder Oil Bath

This unit uses an oil bath lubrication system. Perform the following:

1. Check the oil level through the oil level sight glass (Figure 1) at the rear of the tamper foot.

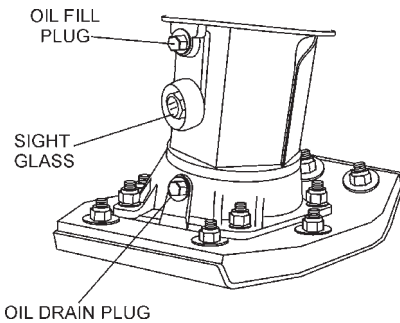

Figure 1. Foot Housing Sight Glass

2. If oil is not visible, add 10W-30 SE, SF or higher grade motor oil into the oil fill plug opening (Figure 1). The bath contains approximately 1.0 pints (520 cc.). The oil level should be kept at the half way point of the sight glass.

**! WARNING Explosive Fuel Hazards**

**Gasoline** is extremely flammable, and its vapors can cause an explosion if ignited. **DO NOT** start the engine near spilled fuel or combustible fluids.

**DO NOT** fill the fuel tank while the engine is running or hot. **DO NOT** overfill tank, since spilled fuel could ignite if it comes into contact with hot engine parts or sparks from the ignition system. Store fuel in approved containers, in well-ventilated areas and away from sparks and flames.



Table 1. Motor Oil Grade	
Season or Temperature	Grade of motor oil (higher than MS class)
Spring, Summer or Autumn +120° F to +15° F	SAE 30
Winter +40° F to +15° F	SAE 30
Below +15° F	SAE 10W-30

### Fuel

1. Fill the fuel tank (Figure 2) with unleaded gasoline. **DO NOT** overfill, wipe up spilled fuel immediately.

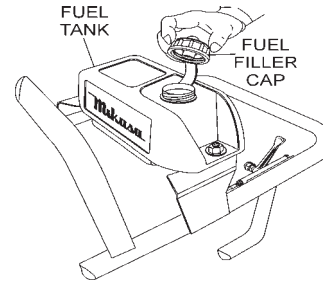

Figure 2. Fuel Tank

### Engine Oil Check

1. To check the engine oil level, place the rammer on secure level ground with the engine stopped.
2. Remove the filler cap/dipstick from the engine oil filler hole (Figure 3) and wipe it clean.

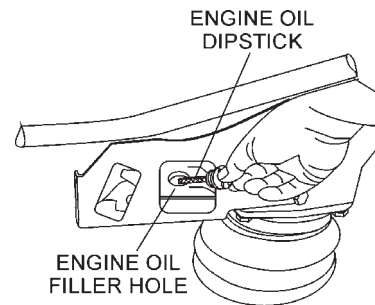

Figure 3. Engine Oil Dipstick

3. Insert and remove the dipstick without screwing it into the filler neck. Check the oil level shown on the dipstick.
4. If the oil level is low (Figure 4), fill to the edge of the oil filler hole with the recommended oil type (Table 1). Maximum oil capacity is .079 gallons (0.3 liters)

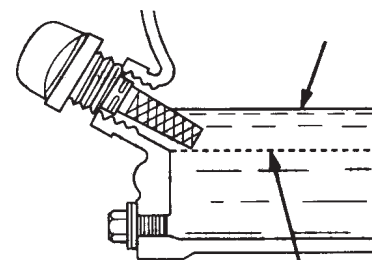

Figure 4. Engine Oil Dipstick (Oil Level)

## Initial Start-up

When starting the MT-55F Tamping Rammer perform the following:

1. Open the **fuel shut-off valve** by moving the **fuel cock** lever to the **open** position (Figure 5).

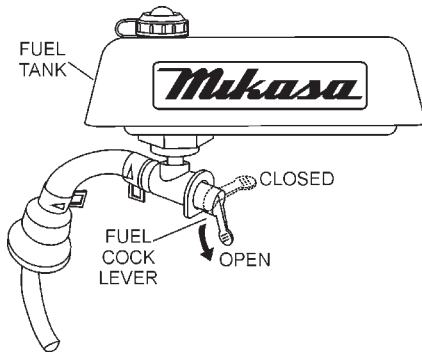

Figure 5. Fuel Shut-Off Valve

2. Set the engine ON/OFF switch (Figure 6) to the "ON" position (start).

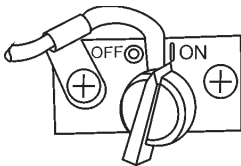

Figure 6. On Off Switch

3. Move the throttle lever to the "IDLE" position (Figure 7).

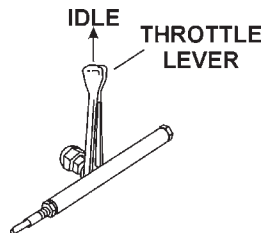

Figure 7. Throttle Lever (Idle)

4. In cold weather, start the unit with choke lever "Fully Closed" (Figure 8). In warm weather or when the engine is warm, the unit can be started with choke halfway or completely **open**.

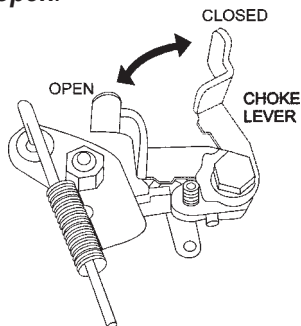

Figure 8. Choke Lever

5. Grip the recoil starter (Figure 9) handle and pull it until you feel a slight resistance. Then pull sharply and quickly. Return the recoil starter handle to the starter case before releasing.

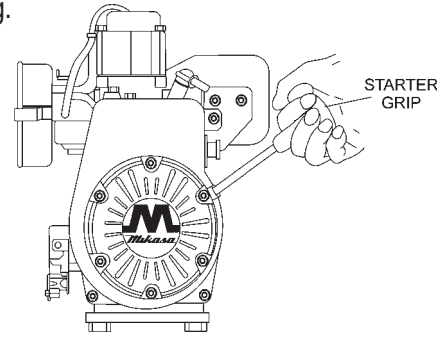

Figure 9. Recoil Starter

6. If engine fails to start, move the choke lever (Figure 8) to the half open position to avoid flooding.
7. Repeat steps 1 thru 6.
8. If the engine does not start after repeated attempts, check the spark plug for excess fuel. Clean and replace the spark plug as needed.

## Operation

1. To start the rammer tamping action, move the throttle lever (Figure 10) **quickly** from **IDLE** (close) to the **FULL OPEN** position. **DO NOT** move the throttle lever slowly as this may cause damage to the clutch or spring.

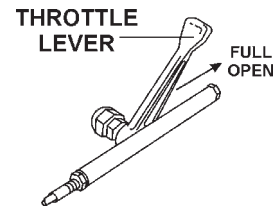

Figure 10. Throttle Lever (Full Open)

## Stopping The Engine

### Normal Shutdown

1. Move throttle lever quickly from the **FULL OPEN** to **IDLE** position (Figure 7) and run the engine for three minutes at low speed.
2. Close the **fuel shut-off valve** (Figure 5) by moving the fuel cock lever to the **CLOSED** position.
3. After the engine **cools**, turn the engine start/stop switch to the "OFF" position (Figure 6).

### Emergency Showdown

1. Move the throttle lever quickly to the **IDLE** position, and turn the engine start/stop switch to the **OFF** position. Turn fuel valve lever to the **CLOSED** position.



MULTIQUIP INC.

POST OFFICE BOX 6254 • CARSON, CA 90749

310-537-3700 • 800-421-1244 • FAX: 310-537-3927

E-MAIL: [mq@multiquip.com](mailto:mq@multiquip.com) • WWW: [multiquip.com](http://multiquip.com)

Montreal, Canada • Manchester, UK

Rio De Janeiro, Brazil • Cipsa, Mexico