

# OPERATION MANUAL



*Mikasa* **SERIES**  
**MODEL MTX70HF**  
**TAMPING RAMMER**  
**(HONDA GX100RTKRB5 GASOLINE ENGINE)**

Revision #4 (06/25/24)

To find the latest revision of this publication or  
associated parts manual, visit our website at:  
[www.multiquip.com](http://www.multiquip.com)



**THIS MANUAL MUST ACCOMPANY THE EQUIPMENT AT ALL TIMES.**

# PROPOSITION 65 WARNING

---





# TABLE OF CONTENTS

---

## **MTX70HF Rammer**

Proposition 65 Warning ..... 2  
Safety Information ..... 5–8  
Specifications ..... 9  
General Information..... 10  
Components ..... 11  
Basic Engine..... 12  
Inspection ..... 13  
Operation..... 14–15  
Maintenance ..... 16  
Troubleshooting (Engine) ..... 17–18  
Troubleshooting (Rammer)..... 19

**NOTICE**  
Specifications and part numbers are subject to change without notice.

# SAFETY INFORMATION

Do not operate or service the equipment before reading the entire manual. Safety precautions should be followed at all times when operating this equipment. Failure to read and understand the safety messages and operating instructions could result in injury to yourself and others.



## SAFETY MESSAGES

The four safety messages shown below will inform you about potential hazards that could injure you or others. The safety messages specifically address the level of exposure to the operator and are preceded by one of four words: **DANGER**, **WARNING**, **CAUTION** or **NOTICE**.

## SAFETY SYMBOLS

<b>DANGER</b>
Indicates a hazardous situation which, if not avoided, <b>WILL</b> result in <b>DEATH</b> or <b>SERIOUS INJURY</b> .
<b>WARNING</b>
Indicates a hazardous situation which, if not avoided, <b>COULD</b> result in <b>DEATH</b> or <b>SERIOUS INJURY</b> .
<b>CAUTION</b>
Indicates a hazardous situation which, if not avoided, <b>COULD</b> result in <b>MINOR</b> or <b>MODERATE INJURY</b> .
<b>NOTICE</b>
Addresses practices not related to personal injury.

Potential hazards associated with the operation of this equipment will be referenced with hazard symbols which may appear throughout this manual in conjunction with safety messages.

Symbol	Safety Hazard
	Lethal exhaust gas hazards
	Explosive fuel hazards
	Burn hazards
	Respiratory hazards
	Accidental starting hazards
	Eye and hearing hazards

# SAFETY INFORMATION

## GENERAL SAFETY

### CAUTION

- **NEVER** operate this equipment without proper protective clothing, shatterproof glasses, respiratory protection, hearing protection, steel-toed boots and other protective devices required by the job or city and state regulations.



- **NEVER** operate this equipment when not feeling well due to fatigue, illness or when under medication.
- **NEVER** operate this equipment under the influence of drugs or alcohol.



- **ALWAYS** check the equipment for loosened threads or bolts before starting.
- **DO NOT** use the equipment for any purpose other than its intended purposes or applications.

### NOTICE

- This equipment should only be operated by trained and qualified personnel 18 years of age and older.
- Whenever necessary, replace nameplate, operation and safety decals when they become difficult read.
- Manufacturer does not assume responsibility for any accident due to equipment modifications. Unauthorized equipment modification will void all warranties.
- **NEVER** use accessories or attachments that are not recommended by Multiquip for this equipment. Damage to the equipment and/or injury to user may result.
- **ALWAYS** know the location of the nearest fire extinguisher.
- **ALWAYS** know the location of the nearest first aid kit.



- **ALWAYS** know the location of the nearest phone or **keep a phone on the job site**. Also, know the phone numbers of the nearest **ambulance, doctor** and **fire department**. This information will be invaluable in the case of an emergency.

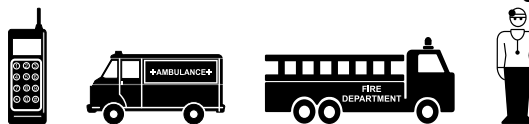

## RAMMER SAFETY

### DANGER

- **NEVER** operate the equipment in an explosive atmosphere or near combustible materials. An explosion or fire could result causing severe **bodily harm or even death**.



### WARNING

- **NEVER** disconnect any **emergency or safety devices**. These devices are intended for operator safety. Disconnection of these devices can cause severe injury, bodily harm or even death. Disconnection of any of these devices will void all warranties.
- **DO NOT** use this machine on ground that is harder than the machine can handle, or for driving pilings or tamping rock beds. Furthermore, use of the machine on sloping ground, such as the side of an embankment, may make the machine unstable and can cause an accident. It can also result in premature machine wear due to uneven loads on the machine.

Use the machine with confidence for tamping earth and sand, soil, gravel, and asphalt. **DO NOT** use the machine for other types of jobs.

### CAUTION

- **NEVER** lubricate components or attempt service on a running machine.

### NOTICE

- **ALWAYS** keep the machine in proper running condition.
- Fix damage to machine and replace any broken parts immediately.
- **ALWAYS** store equipment properly when it is not being used. Equipment should be stored in a clean, dry location out of the reach of children and unauthorized personnel.

# SAFETY INFORMATION

## ENGINE SAFETY

### DANGER

- The engine fuel exhaust gases contain poisonous carbon monoxide. This gas is colorless and odorless, and can cause death if inhaled.
- The engine of this equipment requires an adequate free flow of cooling air. **NEVER** operate this equipment in any enclosed or narrow area where free flow of the air is restricted. If the air flow is restricted it will cause injury to people and property and serious damage to the equipment or engine.



### WARNING

- **DO NOT** place hands or fingers inside engine compartment when engine is running.
- **NEVER** operate the engine with heat shields or guards removed.
- **DO NOT** remove the engine oil drain plug while the engine is hot. Hot oil will gush out of the oil tank and severely scald any persons in the general area of the rammer.



### CAUTION

- **NEVER** touch the hot exhaust manifold, muffler or cylinder. Allow these parts to cool before servicing equipment.



### NOTICE

- **NEVER** run engine without an air filter or with a dirty air filter. Severe engine damage may occur. Service air filter frequently to prevent engine malfunction.
- **NEVER** tamper with the factory settings of the engine or engine governor. Damage to the engine or equipment can result if operating in speed ranges above the maximum allowable.



## FUEL SAFETY

### DANGER

- **DO NOT** add fuel to equipment if it is placed inside truck bed with plastic liner. Possibility exists of explosion or fire due to static electricity.

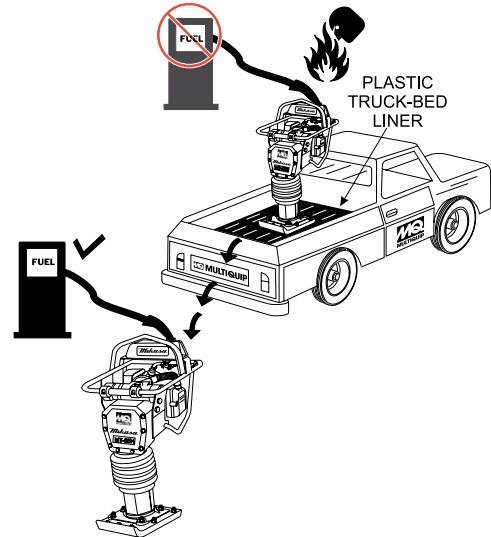

- **DO NOT** start the engine near spilled fuel or combustible fluids. Fuel is extremely flammable and its vapors can cause an explosion if ignited.
- **ALWAYS** refuel in a well-ventilated area, away from sparks and open flames.
- **ALWAYS** use extreme caution when working with **flammable** liquids.
- **DO NOT** fill the fuel tank while the engine is running or hot.
- **DO NOT** overfill tank, since spilled fuel could ignite if it comes into contact with hot engine parts or sparks from the ignition system.
- Store fuel in appropriate containers, in well-ventilated areas and away from sparks and flames.
- **NEVER** use fuel as a cleaning agent.
- **DO NOT** smoke around or near the equipment. Fire or explosion could result from fuel vapors or if fuel is spilled on a hot engine.



## TRANSPORTING SAFETY

### CAUTION

- NEVER allow any person or animal to stand underneath the equipment while lifting.

### NOTICE

- Before lifting, make sure that the equipment parts (hook and vibration insulator) are not damaged and screws are not loose or missing.
- Always make sure crane or lifting device has been properly secured to the lifting bail (hook) of the equipment.
- **ALWAYS** shutdown engine before transporting.
- **NEVER** lift the equipment while the engine is running.
- Tighten fuel tank cap securely and close fuel cock to prevent fuel from spilling.
- Use adequate lifting cable (wire or rope) of sufficient strength.
- Use one point suspension hook and lift straight upwards.
- **DO NOT** lift machine to unnecessary heights.
- **ALWAYS** tie down equipment during transport by securing the equipment with rope.
- Never allow any person or animal to stand underneath the equipment while lifting.

## ENVIRONMENTAL SAFETY

### NOTICE

- Dispose of hazardous waste properly. Examples of potentially hazardous waste are used motor oil, fuel and fuel filters. 
- **DO NOT** use food or plastic containers to dispose of hazardous waste.
- **DO NOT** pour waste, oil or fuel directly onto the ground, down a drain or into any water source.



# SPECIFICATIONS

**Table 1. Rammer Specifications**

Overall Height	40.04 in. (1017 mm)
Overall Width	13.78 in. (350 mm)
Over Length	28.1 in. (713 mm)
Shoe Size (W x L)	13.4 x 11.2 in. (340 x 285 mm)
Fuel Tank Capacity	2.1 qt. (2 liters)
Lubrication Oil Capacity	0.86 qt. (0.82 liter)
No. of Impacts Per Second	10.7 - 11.5
Impact Force	3,350 lbf (14.9 kN)
Impact Plate Stroke	2 - 3.2 in. (50 - 80 mm)
Operating Weight	163.13 lbs. (74 kg)
Measured Sound Power Level	104 dB
Guaranteed Sound Power Level	107 dB
Max. Sound Pressure Level	94 dB

**Table 2. Engine Specifications**

Model	Honda GX100RTKRB5 Engine
Type	Air-Cooled 4 Stroke, Overhead camshaft, single cylinder gasoline engine
Piston Displacement	6.0 cu.in. (98 cc)
Max. Output	3.0 hp/3,600 rpm (2.2 KW)
Max. Governed Speed, No Load	3,800 - 4,100 rpm
Cooling System	Air-Cooled
Engine Oil Capacity	0.3 qt. (0.28 liters)
Fuel	Unleaded gasoline
Lubricant for Engine	Automobile Oil; Class SE or higher
Starting System	Recoil Starter
Spark Plug Type	NGK CR5HSB

# GENERAL INFORMATION

## DEFINITION OF TAMPING RAMMER

The Multiquip MTX70HF tamping rammer is a powerful compacting tool capable of applying a tremendous force in consecutive impacts to a soil surface. Its applications include soil compacting for road, embankments and reservoirs as well as backfilling for gas pipelines, water pipelines and cable installation work.

The impact force of the MTX70HF levels and uniformly compacts voids between soil particles to increase dry density.

Circular motion is converted to create impact force. The MTX70HF tamping rammer develops a powerful compacting force at the foot of the rammer. To maintain optimum performance, proper operation and service are essential.

## CONSTRUCTION OF TAMPING RAMMER

The MTX70HF is equipped with an air cooled, four- cycle gasoline engine. Transmission of the power takes place by increasing the engine speed to engage the centrifugal clutch.

## RAMMER GEARBOX AND SPRING CYLINDER

The MTX70HF uses an oil bath lubrication system. Always check the oil level through the oil level sight glass at the rear of the tamper foot.

## CONTROLS

Before starting the MTX70HF Tamping Rammer identify and understand the function of the controls.

### CAUTION



Before starting operation check the lifting handle to:

1. Make sure that there is no damage on the bolts.
2. Make sure that there is no crack or breakage on handle.
3. Make sure that there is no fissure on the surface. If there is any abnormality or damage, replace with new one.

For operation:

This handle is to be used to lift up the shoe part of the machine with the body laid down on the ground or truck bed.

1. Use proper lifting techniques to avoid back injury. This handle is for manual lifting only.
2. Do not use this handle as a rammer lift point. Use the lifting point on the top of the machine.
3. Do not move the rammer with the lifting handle and the front rollers more than 16 feet (5 meters).

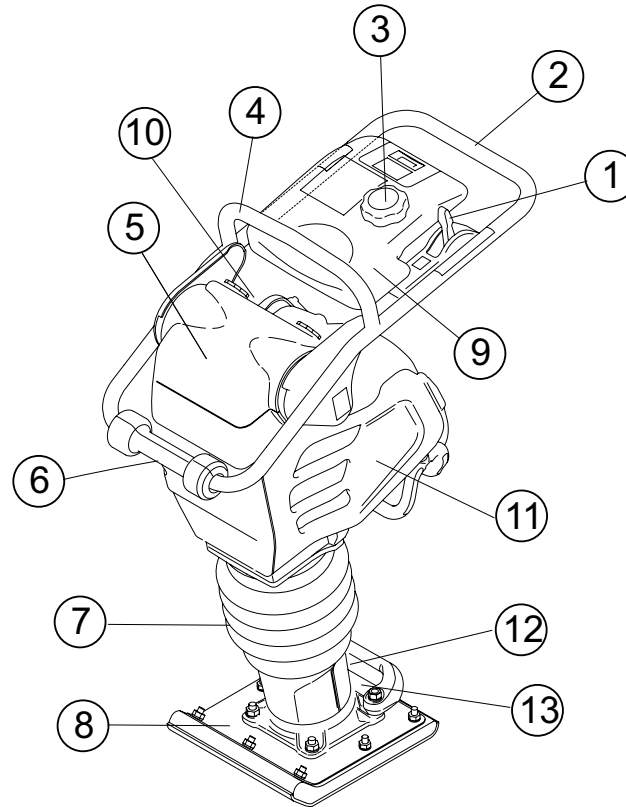

**Figure 1. MTX70HF Rammer**

Figure 1 shows the location of the controls and components for the MTX70HF Tamping Rammer. The functions of each control is described below:

1. **Combination (Throttle) Lever** — Used to adjust engine speed (rpm). Move lever forward (**SLOW**) to reduce engine speed, move lever back toward operator (**FAST**) to increase speed. Always operate the rammer at full speed (rpm).
2. **Handle** — To operate rammer, **GRIP** handle assembly firmly on both sides.
3. **Fuel Tank Cap** — Remove this cap to add unleaded gasoline to the fuel tank. Make sure cap is tightened securely. **DO NOT** over fill.
4. **Hook** — Used to lift rammer for transporting.
5. **Air Cleaner Cover** — Protects the air cleaner which prevents dirt and other debris from entering the engine.
6. **Roller** — Allows rammer to be moved around easily by rolling the unit.
7. **Bellows** — Reservoir for oil bath.
8. **Foot** — Laminated wood with tempered steel plate for superior shock absorption.
9. **Fuel Tank** — Holds the fuel for the unit (up to 2.1quarts).
10. **Muffler** — Reduces the noise of the engine when running.
11. **Engine** — This unit uses a Honda GX100RTKRB5 gasoline engine.
12. **Oil Gauge (Sight Glass)** — Indicates the level of oil in the oil bath reservoir.
13. **Drain Valve** — Open this valve to remove oil from the bellows.

**WARNING**



Adding fuel to the tank should be accomplished only when the engine is stopped and has had an opportunity to cool down. In the event of a fuel spill, **DO NOT** attempt to start the engine until the fuel residue has been completely wiped up, and the area surrounding the engine is dry.

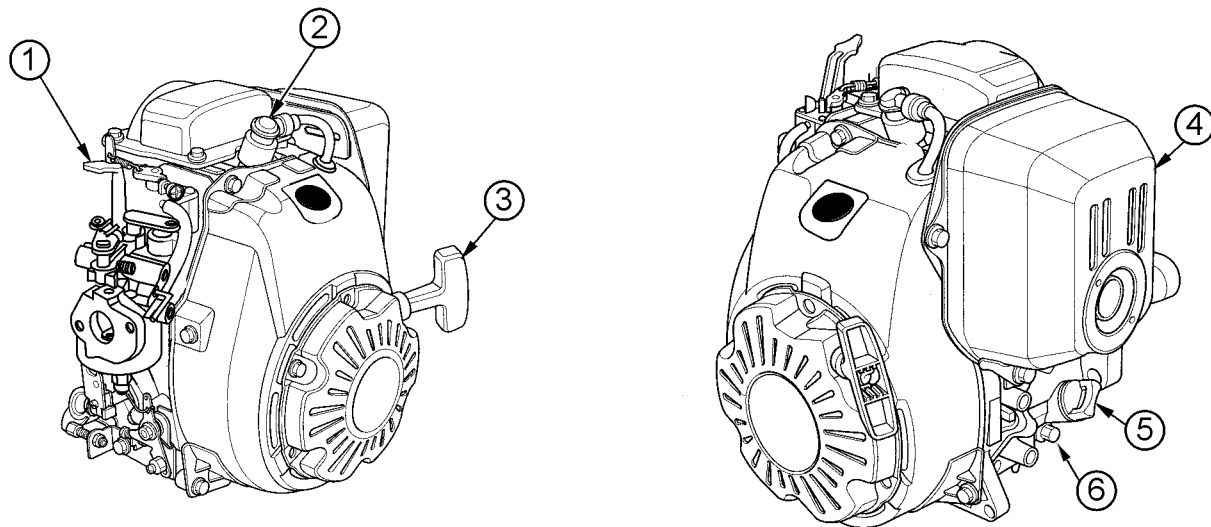

**Figure 2. Honda GX100 Engine**

The engine (Figure 2) must be checked for proper lubrication and filled with fuel prior to operation. Refer to the engine manufacturer's manual for detailed operation and service information.

1. **Choke Lever** — Normally used in starting the engine in cold weather conditions. In cold weather, turn the choke lever to the fully closed position. In warm weather, set the choke lever halfway or completely open.
2. **Spark Plug** — Provides spark to the ignition system. Set spark plug gap to 0.024 - 0.028 inch (0.6 - 0.7 mm). Clean spark plug once a week.
3. **Recoil Starter** (pull rope) — Manual-starting method. Pull the starter grip until resistance is felt, then pull briskly and smoothly.

## NOTICE

Operating the engine without an air filter, with a damaged air filter, or a filter in need of replacement will allow dirt to enter the engine, causing rapid engine wear.

4. **Muffler** — Used to reduce noise and emissions.
5. **Dipstick/Oil Filler Cap** — Remove this cap to determine if the engine oil is low. Add oil through this filler port as recommended in Table 3.
6. **Oil Drain Plug** — Remove this plug to remove oil from the engine's crankcase.

## WARNING



Engine components can generate extreme heat. To prevent burns, **DO NOT** touch these areas while the engine is running or immediately after operating. **NEVER** operate the engine with the muffler removed.

It is extremely important that this section be read carefully before attempting to operate the rammer. **DO NOT** use your rammer until this section is thoroughly understood.

## CRANKCASE AND SPRING CYLINDER OIL BATH

This unit uses an oil bath lubrication system. Perform the following:

1. Check the oil level through the oil level sight glass (Figure 3) at the rear of the tamper foot.

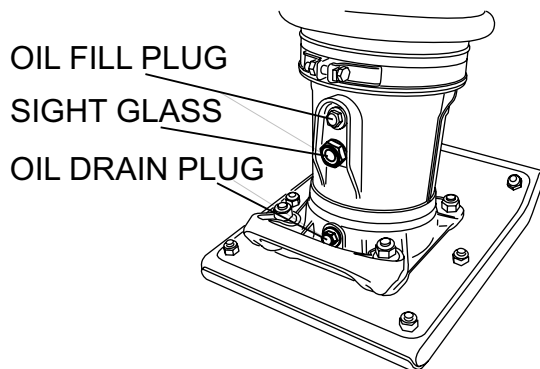

**Figure 3. Foot Housing Sight Glass**

### NOTICE

The oil level should be kept at the half way point of the sight glass.

2. If oil is not visible, add 10W-30 SE, SF or higher grade motor oil into the oil fill plug opening (Figure 3). The bath contains approximately 1.7 pints (820 cc.).

## ENGINE

1. Fill the fuel tank (Figure 4) with unleaded gasoline. At the same time, check the engine oil and make it a habit to replenish it often (Figure 5).

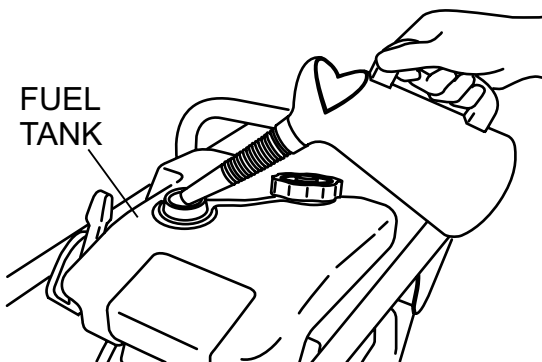

**Figure 4. Fuel Tank**

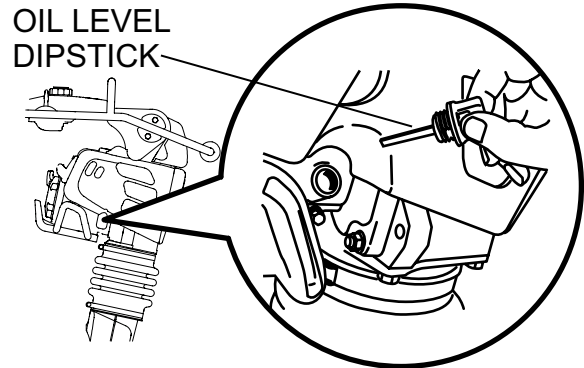

**Figure 5. Engine Oil Dipstick**

2. Low levels of oil may result in engine seizure due to high levels of consumption during operation.
3. Check the engine oil level and if the engine oil level is low, it should be refilled. Use the proper motor oil as suggested in the Table 3 below.

**Table 3. Motor Oil Grade**

Season or Temperature	Grade of motor oil (higher than MS class)
Spring, Summer or Autumn +120° F to +15° F	SAE 30
Winter +40° F to +15° F	SAE 30
Below +15° F	SAE 10W-30

## GENERAL INSPECTION

1. Check all nuts, bolts fasteners for tightness. Retighten as necessary.
2. Clean any dirt from the recoil starter and foot pedestal. Wipe the entire unit clean before operating.
3. Replace any missing or damaged Safety Operation decals.
4. Adjust height of handle. Adjust handle by loosening nuts and moving handle to suit operation. Retighten nuts.

## **CAUTION**

Failure to understand the operation of the Tamping Rammer could result in severe damage to the unit or personal injury.

### INITIAL STARTUP

When starting the MTX70HF Tamping Rammer perform the following:

1. Slide the throttle lever from the stop to the idle position (☛) (Figure 6). This opens the fuel cock and the engine electrical circuit is turned on automatically.

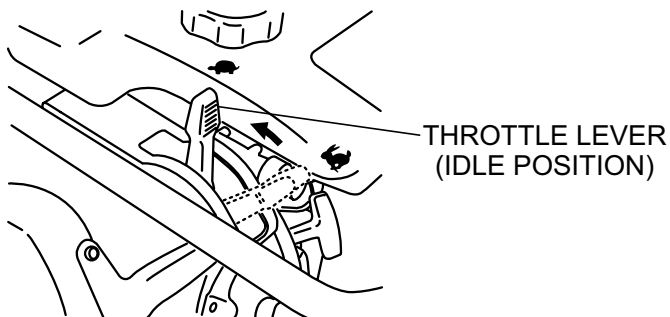

**Figure 6. Throttle Lever (Idle Position)**

2. Place the choke lever to the closed position. When the weather is cold, close the choke all the way. When it is hot, or if the engine is hot, open the choke a little or leave it fully open (Figure 7).

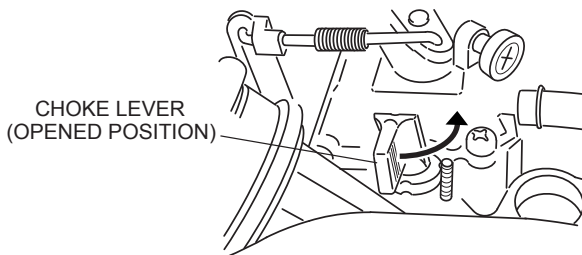

**Figure 7. Choke Lever**

3. Grip the starter rope handle (Figure 8) and pull it until you feel a slight resistance. Then pull sharply and quickly. Return the handle to the starter case before releasing.

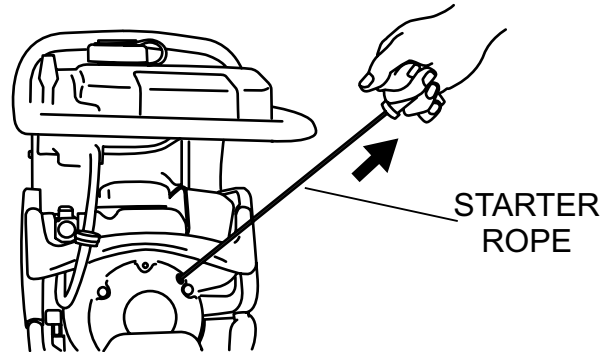

**Figure 8. Recoil Starter**

4. If engine fails to start, move the choke lever (Figure 7) to the half open position to avoid flooding.
5. Repeat steps 1 thru 4.
6. If the engine does not start after repeated attempts, do the following:
  - a. Check fuel delivery from fuel tank to carburetor.
  - b. Check for restrictions to fuel flow at in-tank filter.
  - c. Check for restrictions to fuel flow at in-line filter.
  - d. Inspect spark plug for contamination and proper gap. Clean, adjust or replace spark plug as required.

## OPERATION

1. To start the rammer tamping action, move the throttle lever (Figure 9) **quickly** from **IDLE** to the **START** (  ) position. **DO NOT** move the throttle lever slowly as this may cause damage to the clutch or spring.

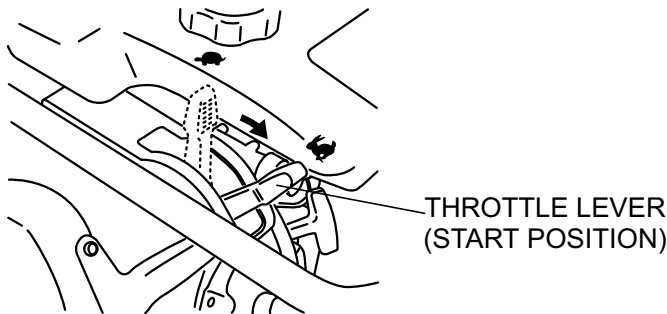

Figure 9. Throttle Lever (Start Position)

### CAUTION

Make sure that the throttle lever is moved to the **FULL START** position. Operating the rammer at less than full speed can result in damage to the clutch springs or foot.

2. The MTX70HF tamping rammer is designed to run at 3,800 to 4,100 rpm. At optimum rpm the foot hits at the rate between 590 - 695 impacts per minute. Increasing throttle speed past factory set rpm does not increase impacts and may damage unit. The MTX70HF is designed to advance while tamping. For faster advance, pull back slightly on the handle so that rear of foot contacts soil first.
3. To stop the tamping action, move throttle lever quickly from **START** to **IDLE** position (Figure 6).

## STOPPING THE ENGINE

1. Move throttle lever quickly from the **START** to **IDLE** position (Figure 6) and run the engine for three minutes at low speed. After the engine **cools**, move the throttle lever to the **STOP** position (Figure 10). The engine will stop and the fuel cock is automatically closed.

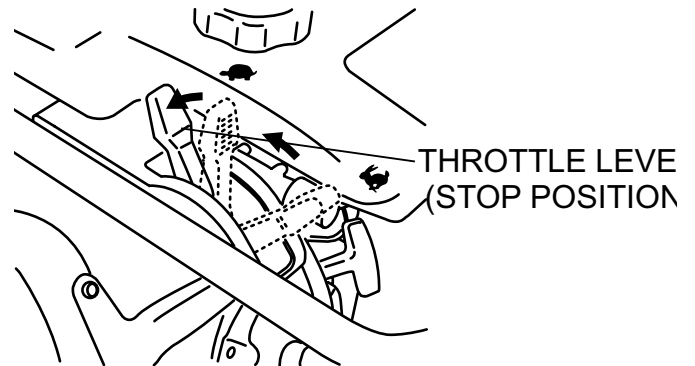

Figure 10. Throttle Lever (Stop Position)

2. If the engine does not stop due to a problem with the switch or the like, move the machine to a safe location and hold the throttle lever in the stop position. Let the machine run on idle and the machine will stop after a few minutes.

Perform the scheduled maintenance procedures as indicated:

## DAILY

- Thoroughly remove dirt and oil from the engine and control area.
- Clean or replace the air cleaner elements as necessary. Check and retighten all fasteners as necessary.
- Check the spring box and bellows for oil leaks. Repair or replace as needed.

## EVERY 50 HOURS

- Remove the fuel filter cap and clean the inside of the fuel tank (Figure 11).

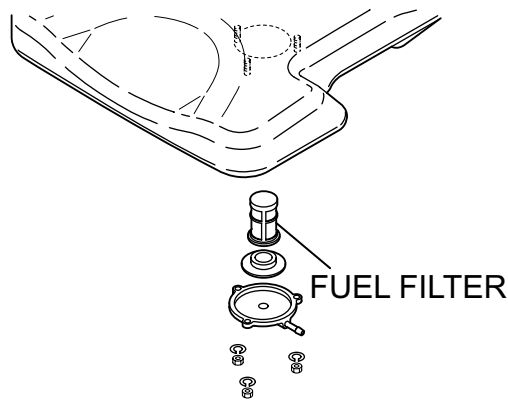

Figure 11. Fuel Filter

- Remove and clean the spark plug, then adjust the spark gap to 0.024~0.028 inch (0.6~0.7 mm).

## EVERY 80 TO 100 HOURS

- Remove the air cleaner cover. Loosen and remove the 2 screws that hold the cover to the air cleaner assembly. If the primary element (Figure 12) is dirty, wash it with gasoline or kerosene. Then dip it in engine oil (SAE10W-30) and wring the element so that 25 to 30 cc of engine oil remains on the element.

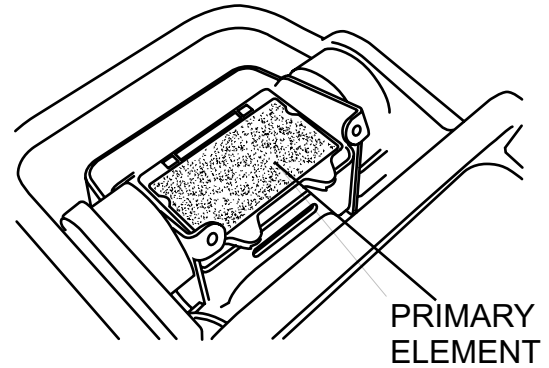

Figure 12. Air Cleaner Primary Element

## EVERY 200 HOURS

- Remove the oil drain plug on foot housing (Figure 13) and drain the oil. Refill with approximately 1.7 pint (800 cc) of 10W-30 SE, SF or higher grade motor oil. Oil should be midway in sight glass. Break in oil should be changed after first 50 hours.

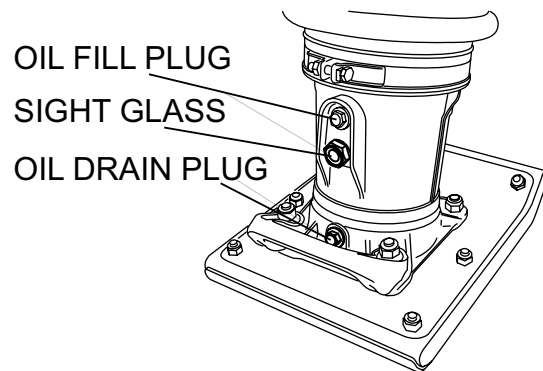

Figure 13. Oil Drain Plug

## EVERY 2 YEARS

- Replace the fuel line every 2 years even if there is no visible damage.

## LONG TERM STORAGE

- Slide the throttle lever to the **STOP** position.
- Drain any fuel including in the fuel hose.
- Replace lubrication oil and apply grease to lubrication points.
- Cover the air intake on the air cleaner and the exhaust outlet on the muffler.
- Store unit indoors covered with plastic sheet in moisture free and dust free location out of direct sunlight.



# TROUBLESHOOTING

<b>Troubleshooting (Engine)</b>		
<b>Symptom</b>	<b>Possible Problem</b>	<b>Solution</b>
Difficult to start, fuel is available, but no spark at spark plug.	Spark plug bridging?	Check gap, insulation or replace spark plug.
	Carbon deposit on spark plug?	Clean or replace spark plug.
	Short circuit due to deficient spark plug insulation?	Check spark plug insulation, replace if worn.
	Improper spark plug gap?	Set to proper gap.
	Spark plug is red?	Check transistor ignition unit.
	Spark plug is bluish white?	If insufficient compression, repair or replace engine. If injected air leaking, correct leak. If carburetor jets clogged, clean carburetor.
	No spark present at tip of spark plug?	Check if transistor ignition unit is broken, and replace defective unit. Check if voltage cord cracked or broken and replace. Check if spark plug is fouled and replace.
	No oil?	Add oil as required.
Difficult to start, fuel is available, and spark is present at the spark plug.	Oil pressure alarm lamp blinks upon starting? (if applicable)	Check automatic shutdown circuit, oil sensor. (if applicable)
	ON/OFF switch is shorted?	Check switch wiring, replace switch.
	Ignition coil defective?	Replace ignition coil.
	Improper spark gap, points dirty?	Set correct spark gap and clean points.
	Condenser insulation worn or short circuiting?	Replace condenser.
Difficult to start, fuel is available, spark is present and compression is normal.	Spark plug wire broken or short circuiting?	Replace defective spark plug wiring.
	Wrong fuel type?	Flush fuel system, replace with correct type of fuel.
	Water or dust in fuel system?	Flush fuel system.
	Air cleaner dirty?	Clean or replace air cleaner.
Difficult to start, fuel is available, spark is present and compression is low.	Choke open?	Close choke.
	Suction/exhaust valve stuck or protruded?	Reseat valves.
	Piston ring and/or cylinder worn?	Replace piston rings and/or piston.
	Cylinder head and/or spark plug not tightened properly?	Torque cylinder head bolts and spark plug.
No fuel present at carburetor.	Head gasket and/or spark plug gasket damaged?	Replace head and spark plug gaskets.
	No fuel in fuel tank?	Fill with correct type of fuel.
	Fuel cock does not open properly?	Apply lubricant to loosen fuel cock lever, replace if necessary.
	Fuel filter/lines clogged?	Replace fuel filter.
	Fuel tank cap breather hole clogged?	Clean or replace fuel tank cap.
	Air in fuel line?	Bleed fuel line.

# TROUBLESHOOTING

<b>Troubleshooting (Engine) - continued</b>		
<b>Symptom</b>	<b>Possible Problem</b>	<b>Solution</b>
Weak in power, compression is proper and does not misfire.	Air cleaner dirty?	Clean or replace air cleaner.
	Improper level in carburetor?	Check float adjustment, rebuild carburetor.
	Defective spark plug?	Clean or replace spark plug.
	Improper spark plug?	Set to proper gap.
Weak in power, compression is proper but misfires.	Water in fuel system?	Flush fuel system and replace with correct type of fuel.
	Dirty spark plug?	Clean or replace spark plug.
	Ignition coil defective?	Replace ignition coil.
Engine overheats.	Wrong type of fuel?	Replace with correct type of fuel.
	Cooling fins dirty?	Clean cooling fins.
	Intake air restricted?	Clear intake of dirt and debris. Replace air cleaner elements as necessary.
	Oil level too low or too high?	Adjust oil to proper level.
Rotational speed fluctuates.	Governor adjusted incorrectly?	Adjust governor.
	Governor spring defective?	Replace governor spring.
	Fuel flow restricted?	Check entire fuel system for leaks or clogs.
Recoil starter malfunctions. (if applicable)	Recoil mechanism clogged with dust and dirt?	Clean recoil assembly with soap and water.
	Spiral spring loose?	Replace spiral spring.
Starter malfunctions.	Loose, damaged wiring?	Ensure tight, clean connections on battery and starter.
	Battery insufficiently charged?	Recharge or replace battery.
	Starter damaged or internally shorted?	Replace starter.
Burns too much fuel.	Over-accumulation of exhaust products?	Check and clean valves. Check muffler and replace if necessary.
	Wrong spark plug?	Replace spark plug with manufacturer's suggested type.
Exhaust color is continuously white.	Lubricating oil is wrong viscosity?	Replace lubricating oil with correct viscosity.
	Worn rings?	Replace rings.
Exhaust color is continuously black.	Air cleaner clogged?	Clean or replace air cleaner.
	Choke valve set to incorrect position?	Adjust choke valve to correct position.
	Carburetor defective, seal on carburetor broken?	Replace carburetor or seal.
	Poor carburetor adjustment, engine runs too rich?	Adjust carburetor.
Will not start, no power with key ON. (if applicable)	ON/OFF device not activated ON?	Turn on ON/OFF device.
	Battery disconnected or discharged?	Check cable connections. Charge or replace battery.
	Ignition switch/wiring defective?	Replace ignition switch. Check wiring.

# TROUBLESHOOTING

<b>Troubleshooting (Rammer)</b>		
<b>Symptom</b>	<b>Possible Problem</b>	<b>Solution</b>
Engine runs but rammer jumps erratically or not at all.	Operating speed of throttle lever is incorrectly set?	Set throttle lever to correct position.
	Oil in excess?	Drain excess oil. Bring to correct level.
	Clutch slips?	Replace or adjust clutch.
	Spring Failure?	Replace spiral spring.
	Speed of engine improper?	Adjust engine speed to correct operating RPM setting.
	Soil over-compacted?	Shut down machine and test soil.

# OPERATION MANUAL

## HERE'S HOW TO GET HELP

PLEASE HAVE THE MODEL AND SERIAL  
NUMBER ON-HAND WHEN CALLING

### UNITED STATES

#### *Multiquip Inc.*

(310) 537- 3700  
6141 Katella Avenue Suite 200  
Cypress, CA 90630  
E-MAIL: [mq@multiquip.com](mailto:mq@multiquip.com)  
WEBSITE: [www.multiquip.com](http://www.multiquip.com)

### CANADA

#### *Multiquip*

(450) 625-2244  
4110 Industriel Boul.  
Laval, Quebec, Canada H7L 6V3  
E-MAIL: [infocanada@multiquip.com](mailto:infocanada@multiquip.com)

### UNITED KINGDOM

#### *Multiquip (UK) Limited Head Office*

0161 339 2223  
Unit 2, Northpoint Industrial Estate,  
Globe Lane,  
Dukinfield, Cheshire SK16 4UJ  
E-MAIL: [sales@multiquip.co.uk](mailto:sales@multiquip.co.uk)

© COPYRIGHT 2024, MULTIQUIP INC.

Multiquip Inc, the MQ logo are registered trademarks of Multiquip Inc. and may not be used, reproduced, or altered without written permission. All other trademarks are the property of their respective owners and used with permission.

This manual MUST accompany the equipment at all times. This manual is considered a permanent part of the equipment and should remain with the unit if resold.

The information and specifications included in this publication were in effect at the time of approval for printing. Illustrations, descriptions, references and technical data contained in this manual are for guidance only and may not be considered as binding. Multiquip Inc. reserves the right to discontinue or change specifications, design or the information published in this publication at any time without notice and without incurring any obligations.

