



# UPA-88/UPA-88A Walk-Behind Plate Compactor

## Urethane Plate Installation Kit Instructions

The following instructions are intended to assist the user in installing the UPA-88/UPA-88A Kit, Urethane Plate Attachment to the Multiquip MVC-88 Series plate compactors. The UPA-88/UPA-88A are designed for compacting paving stones and decorative brick. The pad prevents damage to the stone as the plate passes over the surface. It is not intended for soil or backfill compaction. Please read the instructions before assembling.

### REQUIRED TOOLS

- 3/8" Ratchet/Socket Set

### PARTS

Verify that all parts are accounted for. See Figure 1 and Table 1.

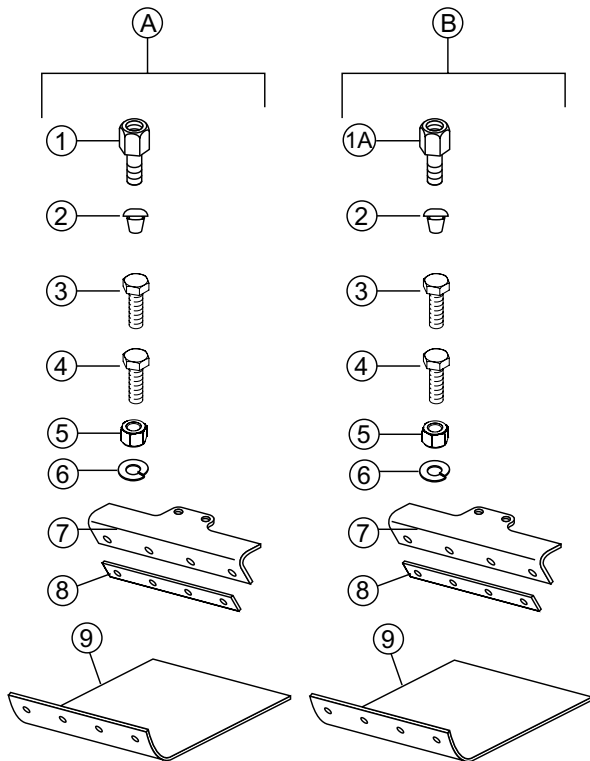

Figure 1. Kit Parts

Table 1. Kit Parts

Item No.	Part No.	Description	Qty.	Remarks
A	UPA-88	Kit, Urethane Plate Attachment*	1	Includes items 1-7
B	UPA-88A	Kit, Urethane Plate Attachment**	1	Includes items 1A-7
1	416456210	Interlocking Bolt, 16x35"	1	UPA88
1A	416456211	Interlocking Bolt, 16x40"	1	UPA88A
2	416010030	Cap	2	
3	012012030	Bolt 12x30	2	
4	011208035	Bolt 8x35	4	
5	022710809	Nylon Nut M8	4	
6	030212300	Washer, Lock M12	2	
7	416342380	Hanger Block Plate	1	
8	416342370	Plate	1	
9	PADUPA88	Urethane Pad	1	
*Casing P/N 416115990, Height = 7/16" (MVC88 W/ S/N K6886 and Below.				
**Casing P/N 416115991, Height = 9/16" (MVC88 W/ S/N K6887 and Above.				

### WORK SAFELY!

Only a **qualified service technician** with proper training should perform this installation. Follow all shop safety rules when performing this installation.

## URETHANE PLATE INSTALLATION

1. Using a 3/8" ratchet and 24 mm socket, remove and **discard** the 2 eccentric mounting bolts (Figure 2) at the front of the plate compactor.

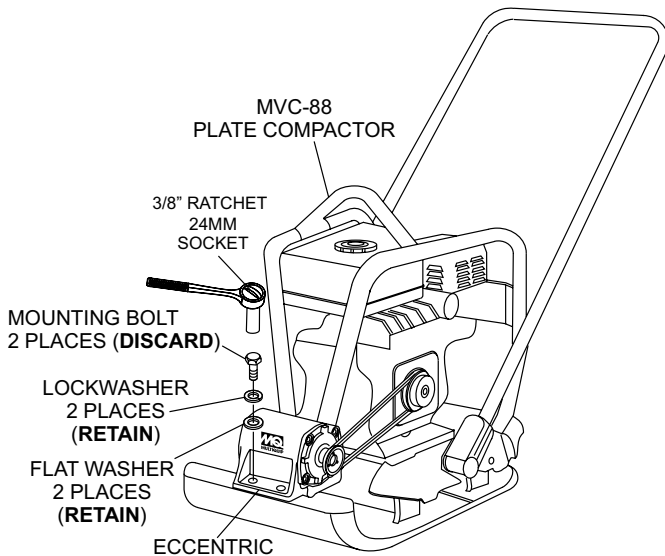

**Figure 2. Eccentric Mounting Bolts Removal**

2. **Retain** the 2 lock washers and 2 flat washers. These items will be used later.
3. Apply Loctite™ #271 (RED) to the male threads on the interlocking bolts (item 1 or 1A). Reference Figure 3
4. Using a 3/8" ratchet and 24 mm socket, insert the 2 interlocking bolts in place of the discarded eccentric mounting bolts (step 1) using the existing lock washers and flat washers. Torque interlocking bolts to 203 ft-lb.

5. Align the 4 holes on the plate (item 8) with the 4 holes on the front of the urethane pad (item 9).
6. Insert the four 8x35 bolts (item 4) through the plate (item 8) and urethane pad (item 9) mounting holes.
7. Attach the plate and urethane pad (items 8 and 9) to the hanger block plate (item 7) by inserting the 4 bolts sticking out from the plate/urethane pad into the hanger block plate mounting holes.
8. To finish securing the plate and urethane pad to the hanger block plate, use a 3/8" ratchet and 13 mm socket and tighten the four 8x35 bolts (item 4) securely. Bolts are secured using the 4 nylon nuts (item 5).
9. Lay the assembled urethane pad flat on the ground and place the plate compactor on top of the pad with the hanger block plate about 2 to 3 inches from the front of the compactor's base plate.
10. Slide in the assembled urethane pad towards the compactor aligning the 2 holes on the hanger block plate with the the 2 interlocking bolts that were inserted in step 4.
11. Using a 3/8" ratchet and 19 mm socket, install the two 12x30 bolts (item 3) and 2 lock washers (item 6) into the hanger block plate mounting holes. Torque screws to 86.8 ft-lb. **DO NOT USE LOCTITE OR OVERTIGHTEN.**

### NOTICE

Insert cap (item 2), P/N 416010030 into interlocking bolts when urethane pad and hanger block plate are not in use. This will keep the bolt threads clean.

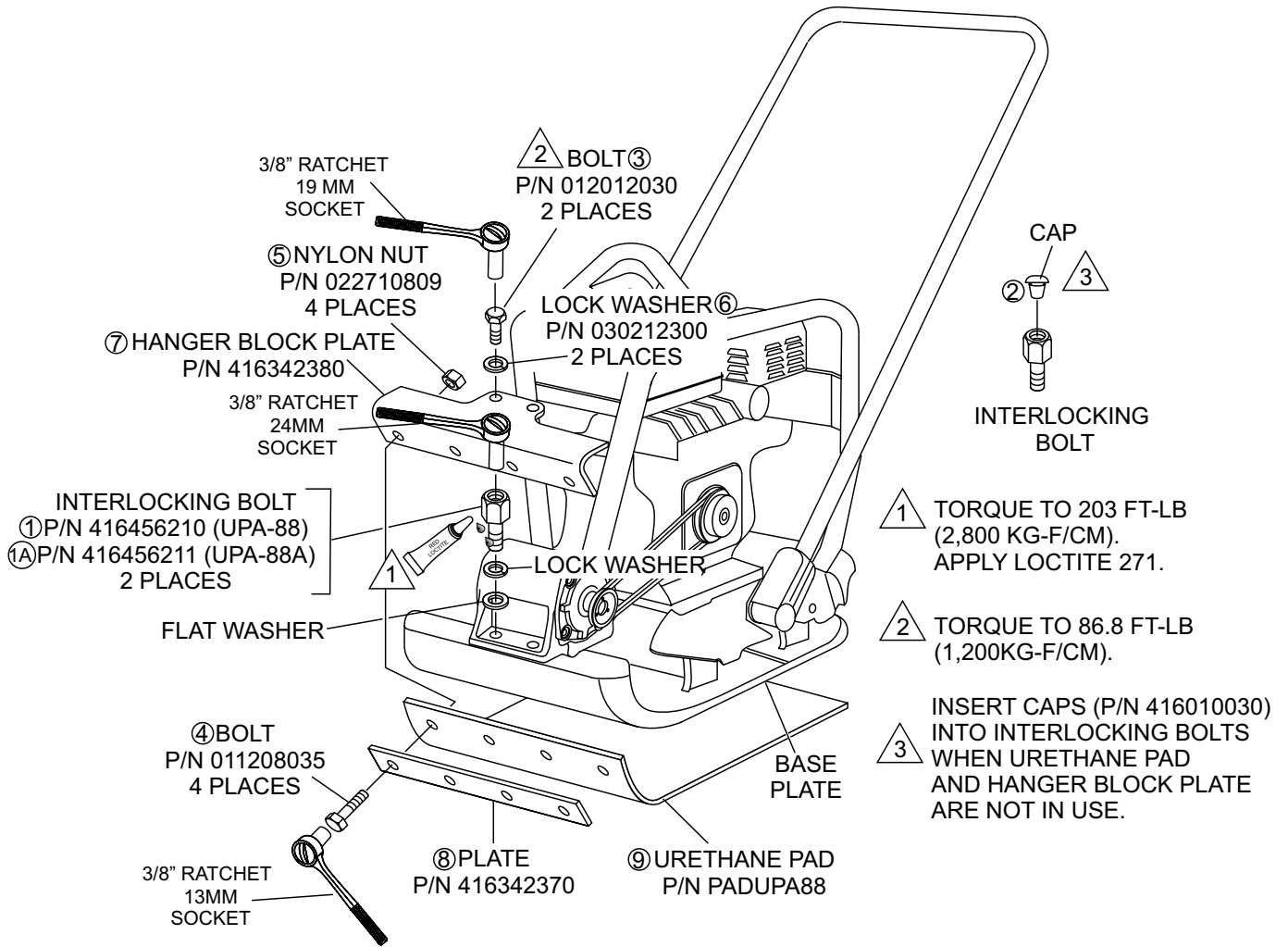

**Figure 3. Location of Parts and Components**



# UPA-88/UPA88 Walk-Behind Plate Compactor

## Urethane Plate Installation Kit Instructions

---

## HERE'S HOW TO GET HELP

PLEASE HAVE THE MODEL AND SERIAL  
NUMBER ON-HAND WHEN CALLING

### UNITED STATES

#### *Multiquip Corporate Office*

18910 Wilmington Ave. Tel. (800) 421-1244  
Carson, CA 90746 Fax (310) 537-3927  
Contact: mq@multiquip.com

#### *Service Department*

800-421-1244 Fax: 310-537-4259  
310-537-3700

#### *Technical Assistance*

800-478-1244 Fax: 310-943-2238

#### *MQ Parts Department*

800-427-1244 Fax: 800-672-7877  
310-537-3700 Fax: 310-637-3284

#### *Warranty Department*

800-421-1244 Fax: 310-943-2249  
310-537-3700

---

### MEXICO

#### *MQ Cipsa*

Carr. Fed. Mexico-Puebla KM 126.5 Tel: (52) 222-225-9900  
Momoxpan, Cholula, Puebla 72760 Mexico Fax: (52) 222-285-0420  
Contact: pmastretta@cipsa.com.mx

### CANADA

#### *Multiquip*

4110 Industriel Boul. Tel: (450) 625-2244  
Laval, Quebec, Canada H7L 6V3 Tel: (877) 963-4411  
Contact: jmartin@multiquip.com Fax: (450) 625-8664

---

### UNITED KINGDOM

#### *Multiquip (UK) Limited Head Office*

Unit 2, Northpoint Industrial Estate, Tel: 0161 339 2223  
Globe Lane, Fax: 0161 339 3226  
Dukinfield, Cheshire SK16 4UJ  
Contact: sales@multiquip.co.uk

© COPYRIGHT 2013, MULTIQUIP INC.

Multiquip Inc and the MQ logo are registered trademarks of Multiquip Inc. and may not be used, reproduced, or altered without written permission. All other trademarks are the property of their respective owners and used with permission.

The information and specifications included in this publication were in effect at the time of approval for printing. Illustrations, descriptions, references and technical data contained in this document are for guidance only and may not be considered as binding. Multiquip Inc. reserves the right to discontinue or change specifications, design or the information published in this publication at any time without notice and without incurring any obligations.

Your Local Dealer is:

