

OPERATION MANUAL



Mikasa **SERIES**
MODEL MVH206D
REVERSIBLE PLATE COMPACTOR
(YANMAR L70V6GF1R1AA DIESEL ENGINE)

Revision #3 (07/08/20)

To find the latest revision of this publication or
associated parts manual, visit our website at:
www.multiquip.com



THIS MANUAL MUST ACCOMPANY THE EQUIPMENT AT ALL TIMES.

PROPOSITION 65 WARNING



**MVH206D REVERSIBLE
PLATE COMPACTOR**

Proposition 65 Warning 2
Table ofContents 3
Safety Information 4-8
Specifications 9
Dimensions 10
General Information 11
Controls and Components 12
Basic Engine 13
Inspection 14-15
Operation 16-19
Maintenance 20-23
Troubleshooting (Engine) 24
Troubleshooting (Compactor) 25

NOTICE

Specification and part number are subject to change without notice

SAFETY INFORMATION

Do not operate or service the equipment before reading the entire manual. Safety precautions should be followed at all times when operating this equipment. Failure to read and understand the safety messages and operating instructions could result in injury to yourself and others.



SAFETY MESSAGES

The four safety messages shown below will inform you about potential hazards that could injure you or others. The safety messages specifically address the level of exposure to the operator and are preceded by one of four words: **DANGER**, **WARNING**, **CAUTION** or **NOTICE**.

SAFETY SYMBOLS

! DANGER

Indicates a hazardous situation which, if not avoided, **WILL** result in **DEATH** or **SERIOUS INJURY**.

! WARNING

Indicates a hazardous situation which, if not avoided, **COULD** result in **DEATH** or **SERIOUS INJURY**.

! CAUTION

Indicates a hazardous situation which, if not avoided, **COULD** result in **MINOR** or **MODERATE INJURY**.

NOTICE

Addresses practices not related to personal injury.

Potential hazards associated with the operation of this equipment will be referenced with hazard symbols which may appear throughout this manual in conjunction with safety messages.

Symbol	Safety Hazard
	Lethal exhaust gas hazards
	Explosive fuel hazards
	Burn hazards
	Respiratory hazards
	Accidental starting hazards
	Eye and hearing hazards
	Rotating parts hazards

SAFETY INFORMATION

GENERAL SAFETY

⚠ CAUTION

- **NEVER** operate this equipment without proper protective clothing, shatterproof glasses, respiratory protection, hearing protection, steel-toed boots and other protective devices required by the job or city and state regulations.



- **NEVER** operate this equipment when not feeling well due to fatigue, illness or when under medication.



- **NEVER** operate this equipment under the influence of drugs or alcohol.



- **ALWAYS** check the equipment for loosened threads or bolts before starting.
- **DO NOT** use the equipment for any purpose other than its intended purposes or applications.
- **ALWAYS** clear the work area of any debris, tools, etc. that would constitute a hazard while the equipment is in operation.

NOTICE

- This equipment should only be operated by trained and qualified personnel 18 years of age and older.
- Whenever necessary, replace nameplate, operation and safety decals when they become difficult read.
- Manufacturer does not assume responsibility for any accident due to equipment modifications. Unauthorized equipment modification will void all warranties.
- **NEVER** use accessories or attachments that are not recommended by Multiquip for this equipment. Damage to the equipment and/or injury to user may result.
- **ALWAYS** know the location of the nearest **fire extinguisher**.
- **ALWAYS** know the location of the nearest **first aid kit**.
- **ALWAYS** know the location of the nearest phone or **keep a phone on the job site**. Also, know the phone numbers of the nearest **ambulance, doctor and fire department**. This information will be invaluable in the case of an emergency.

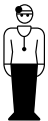

SAFETY INFORMATION

COMPACTOR SAFETY

DANGER

- **NEVER** operate the equipment in an explosive atmosphere or near combustible materials. An explosion or fire could result causing severe **bodily harm or even death.**



WARNING

- **NEVER** disconnect any **emergency or safety devices.** These devices are intended for operator safety. Disconnection of these devices can cause severe injury, bodily harm or even death. Disconnection of any of these devices will void all warranties.

CAUTION

- **NEVER** lubricate components or attempt service on a running machine.

NOTICE

- **ALWAYS** keep the machine in proper running condition.
- Fix damage to machine and replace any broken parts immediately.
- **ALWAYS** store equipment properly when it is not being used. Equipment should be stored in a clean, dry location out of the reach of children and unauthorized personnel.

ENGINE SAFETY

DANGER

- The engine fuel exhaust gases contain poisonous carbon monoxide. This gas is colorless and odorless, and can cause death if inhaled.
- The engine of this equipment requires an adequate free flow of cooling air. **NEVER** operate this equipment in any enclosed or narrow area where free flow of the air is restricted. If the air flow is restricted it will cause injury to people and property and serious damage to the equipment or engine.



WARNING

- **DO NOT** place hands or fingers inside engine compartment when engine is running.
- **NEVER** operate the engine with heat shields or guards removed.
- Keep fingers, hands hair and clothing away from all moving parts to prevent injury.
- **DO NOT** remove the radiator cap while the engine is hot. High pressure boiling water will gush out of the radiator and severely scald any persons in the general area of the compactor.
- **DO NOT** remove the coolant drain plug while the engine is hot. Hot coolant will gush out of the coolant tank and severely scald any persons in the general area of the compactor.
- **DO NOT** remove the engine oil drain plug while the engine is hot. Hot oil will gush out of the oil tank and severely scald any persons in the general area of the compactor.



CAUTION

- **NEVER** touch the hot exhaust manifold, muffler or cylinder. Allow these parts to cool before servicing equipment.



NOTICE

- **NEVER** run engine without an air filter or with a dirty air filter. Severe engine damage may occur. Service air filter frequently to prevent engine malfunction.
- **NEVER** tamper with the factory settings of the engine or engine governor. Damage to the engine or equipment can result if operating in speed ranges above the maximum allowable.
- **NEVER** tip the engine to extreme angles during lifting as it may cause oil to gravitate into the cylinder head, making the engine start difficult.





SAFETY INFORMATION

FUEL SAFETY

DANGER

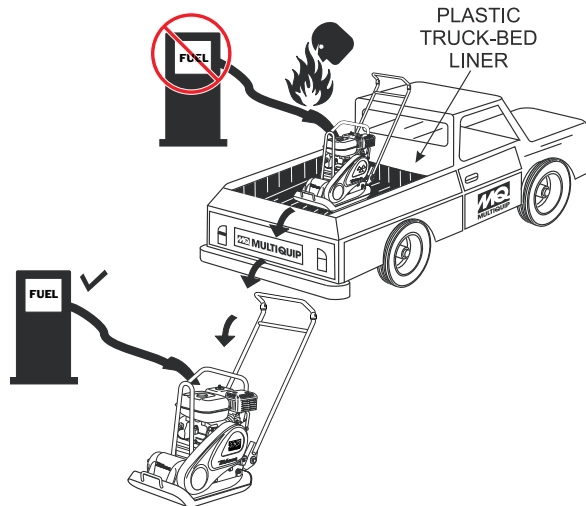
- **DO NOT** add fuel to equipment if it is placed inside truck bed with plastic liner. Possibility exists of explosion or fire due to static electricity.





- **DO NOT** start the engine near spilled fuel or combustible fluids. Diesel fuel is extremely flammable and its vapors can cause an explosion if ignited.
- **ALWAYS** refuel in a well-ventilated area, away from sparks and open flames.
- **ALWAYS** use extreme caution when working with **flammable** liquids.
- **DO NOT** fill the fuel tank while the engine is running or hot.
- **DO NOT** overfill tank, since spilled fuel could ignite if it comes into contact with hot engine parts or sparks from the ignition system.
- Store fuel in appropriate containers, in well-ventilated areas and away from sparks and flames.
- **NEVER** use fuel as a cleaning agent.
- **DO NOT** smoke around or near the equipment. Fire or explosion could result from fuel vapors or if fuel is spilled on a hot engine. 

BATTERY SAFETY (ELECTRIC START ONLY)

DANGER

- **DO NOT** drop the battery. There is a possibility that the battery will explode.
- **DO NOT** expose the battery to open flames, sparks, cigarettes, etc. The battery contains combustible gases and liquids. If these gases and liquids come into contact with a flame or spark, an explosion could occur. 

WARNING

- **ALWAYS** wear safety glasses when handling the battery to avoid eye irritation. The battery contains acids that can cause injury to the eyes and skin. 
- Use well-insulated gloves when picking up the battery.
- **ALWAYS** keep the battery charged. If the battery is not charged, combustible gas will build up.
- **DO NOT** charge battery if frozen. Battery can explode. When frozen, warm the battery to at least 61°F (16°C).
- **ALWAYS** recharge the battery in a well-ventilated environment to avoid the risk of a dangerous concentration of combustible gases.
- If the battery liquid (dilute sulfuric acid) comes into contact with **clothing or skin**, rinse skin or clothing immediately with plenty of water. 
- If the battery liquid (dilute sulfuric acid) comes into contact with **eyes**, rinse eyes immediately with plenty of water and contact the nearest doctor or hospital to seek medical attention.

CAUTION

- **ALWAYS** disconnect the **NEGATIVE** battery terminal before performing service on the equipment.
- **ALWAYS** keep battery cables in good working condition. Repair or replace all worn cables.

TRANSPORTING SAFETY

CAUTION

- NEVER allow any person or animal to stand underneath the equipment while lifting.

NOTICE

- Before lifting, make sure that the equipment parts (hook and vibration insulator) are not damaged and screws are not loose or missing.
- Always make sure crane or lifting device has been properly secured to the lifting bail (hook) of the equipment.
- **ALWAYS** shutdown engine before transporting.
- **NEVER** lift the equipment while the engine is running.
- Tighten fuel tank cap securely and close fuel cock to prevent fuel from spilling.
- Use adequate lifting cable (wire or rope) of sufficient strength.
- Use one point suspension hook and lift straight upwards.
- **DO NOT** lift machine to unnecessary heights.
- **ALWAYS** tie down equipment during transport by securing the equipment with rope.

ENVIRONMENTAL SAFETY

NOTICE

- Dispose of hazardous waste properly. Examples of potentially hazardous waste are used motor oil, fuel and fuel filters. 
- **DO NOT** use food or plastic containers to dispose of hazardous waste.
- **DO NOT** pour waste, oil or fuel directly onto the ground, down a drain or into any water source.

SPECIFICATIONS

Table 1. MVH-206D Specifications

Centrifugal Force	7,870 lbf (35 kN)
Vibration Frequency	5,200 vpm (86.7 Hz)
Traveling Speed	0 to 75 ft/min (0 to 23 m/min)
Plate Size (L x W)	28.4 x 19.7 in (720 x 500 mm)
Max. Area of Compaction	7,380 sq. ft./h (690 sq. meters/h)
Operating Weight	494 lbs (224 kg)
Vibrating Oil Capacity	0.63 quart (0.6 liter)

Table 2. Engine Specifications

Model	YANMAR L70V6GF1R1AA
Type	Air-cooled, 4-cycle Diesel Engine
Bore X Stroke	3.07 in. X 2.64 in. (78 mm x 67 mm.)
Displacement	19.5 cu. in. (320 cc)
Max Power Output	6.4 HP (4.8 KW) @ 3600 R.P.M.
Fuel Tank Capacity	3.5 quarts (3.3 liters)
Fuel	No. 2 Diesel Fuel
Operating Speed	3,200 rpm
Lube Oil Capacity	1.2 quarts (1.1 liters)
Speed Control Method	Centrifugal Flyweight Type
Starting Method	Recoil Start

DIMENSIONS

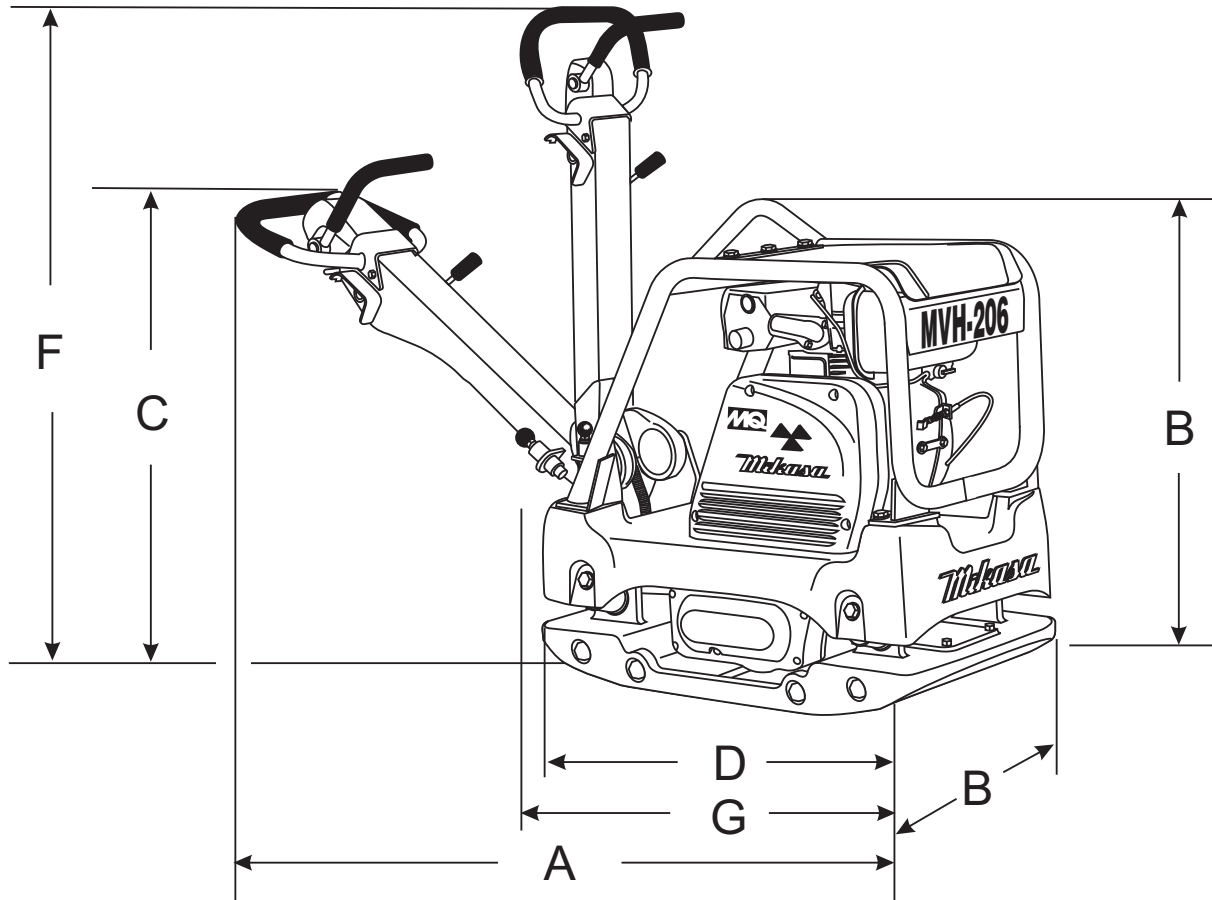

Figure 1. MVH206D Dimensions

Table 3. Dimensions		
Reference	Description	Measurement
A	Length (Handle in Working Position)	54.3 in (1,380 mm)
B	Height of Main Body	30 in (763 mm)
C	Height (Handle in Working Position)	34 in (1,100mm)
D	Lenght of Plate	28.4 in (720 mm)
E	Width of Plate	19.7 in (500 mm)
F	Height (Handle in Vertical Position)	51.6 in (1,310 mm)
G	Length (Handle in Vertical Position)	31.5 in (800 mm)

PLATE COMPACTOR

The Mikasa MVH-206D is a walk behind, reversible plate compactor designed for the compaction of sand, clay and asphalt. This plate compactor is a powerful compacting tool capable of applying a tremendous force in consecutive high frequency vibrations to a soil surface. Its applications include soil compacting for road, embankments and reservoirs as well as backfilling for gas pipelines, water pipelines and cable installation work.

VIBRATORY PLATES

The vibratory plates of the MVH-206D produce low amplitude high frequency vibrations, designed to compact granular soils.

The resulting vibrations cause forward motion. The engine and handle are vibration isolated from the vibrating plate. The heavier the plate, the more compaction force it generates.

REVERSIBLE VIBRATORY PLATES

Reversible vibratory plates have two eccentric weights that allow a smooth transition for forward and reverse travel, plus increased compaction force as the result of dual weights.

Due to their weight and force, reversible plates are ideal for semi-cohesive soils.

FREQUENCY/SPEED

The compactor's vibrating plate maximum frequency is 5200 vpm (vibrations per minute). The forward and reverse travel speed of the compactor is approximately 75 feet/minute (23 meters/minute).

ENGINE

The Mikasa MVH-206D Plate Compactor is equipped with a Yanmar L70V6GF1R1AA (recoil start) diesel engine.

CONTROLS

Before starting the MVH-206D Plate Compactor, identify and understand the function of the controls and components.

CONTROLS AND COMPONENTS

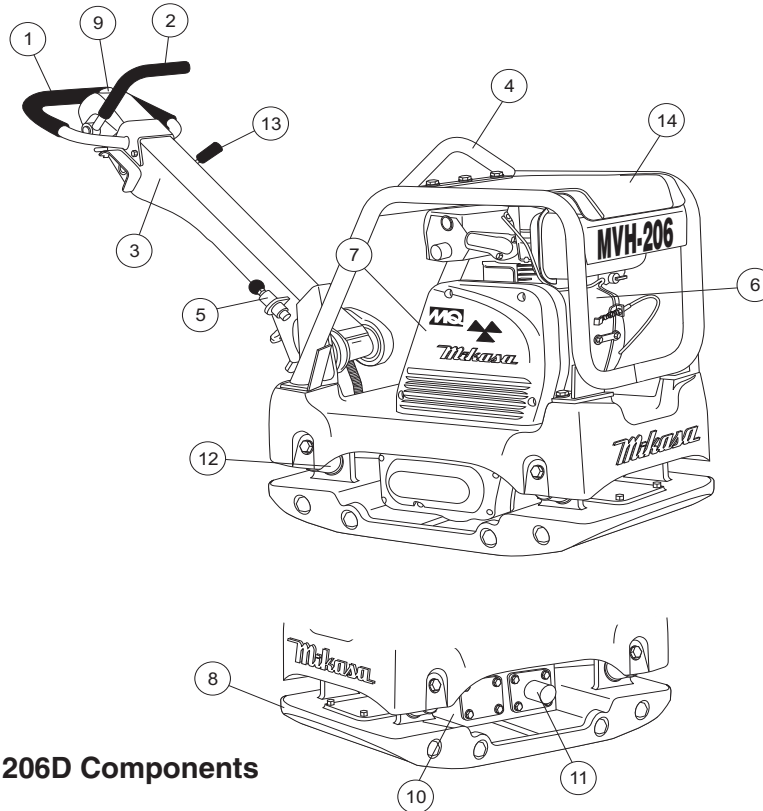

Figure 2. MVH206D Components

Figure 2 illustrates the location of the major components for the MVH-206D Reversible Plate Compactor. The function of each component is described below:

1. **Hand Grip** – When operating the compactor use this hand grip to maneuver the compactor.
2. **Forward and Reverse Lever** – *Push* the lever forward, the compactor will move in a forward direction. *Pull* the lever backwards, the compactor will move in reverse direction. Placing the lever in the middle (midway) will cause the compactor not to move (neutral).
3. **Handle Bar** – When operating the compactor, this handle should be in the downward position. When the compactor is to be **stored**, move the handle bar to the upright position.
4. **Guard Hook** - Used to lift the machine with a crane or other lifting device.
5. **Stopper** - Locks the handle in place in the upward position for stowing.
6. **Engine** – This plate compactor uses a **YANMAR L70V6GF1R1AA** diesel engine. Refer to the engine owner's manual for engine information.
7. **Belt Cover** – Remove this cover to gain access to the V-belts. **NEVER** run the compactor without the V-belt cover. If the V-belt cover is not installed, the possibility exists of your hand getting caught between the V-belt and clutch, thus causing serious injury and bodily harm.
8. **Base Plate** – Designed to compact sand, clay, and asphalt.
9. **Oil Reservoir** – Fill with Shell Tellus Oil 46 or equivalent grade hydraulic oil.
10. **Vibration Case** – Encloses the eccentric, gears and counter weights.
11. **Hydraulic Cylinder** – Activated by moving the travel lever. The cylinder controls the direction of movement by the plate compactor.
12. **Shock Absorber** – Protects plate compactor from damage by absorbing vibration during operation.
13. **Throttle Lever** – Controls speed of the plate compactor. Place straight vertically to start, **push** fully counterclockwise for full throttle and fully clockwise to stop plate compactor.
14. **Rubber Cover** – Lift this rubber cover to gain access to the fuel tank.

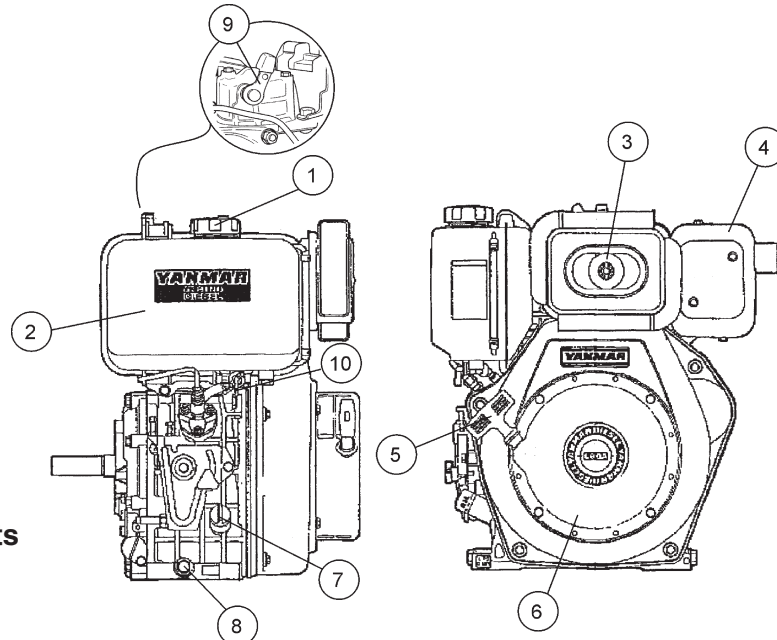



Figure 3. YANMAR Engine Components

The engine shown above is a **YANMAR** engine (Figure 3). It must be checked for proper lubrication and filled with fuel prior to operation. Refer to the engine manual for operation and servicing information.

1. **Fuel Filler Cap** – Remove this cap to add unleaded gasoline to the fuel tank. Make sure cap is tightened securely. **DO NOT** over fill.
2. **Fuel Tank** – Holds 3.5 quarts (3.3 liters) of diesel fuel. For additional information refer to engine owner's manual.

⚠ DANGER — Fuel Hazard



Adding fuel to the tank should be done only when the engine is stopped and has had an opportunity to cool down. In the event of a fuel spill, **DO NOT** attempt to start the engine until the fuel residue has been completely wiped up and the area surrounding the engine is dry.

3. **Air Cleaner** – Prevents dirt and other debris from entering the fuel system. Remove wing-nut on top of air filter cannister to gain access to filter element.

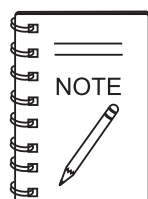

Operating the engine without an air filter, with a damaged air filter, or a filter in need of replacement will allow dirt to enter the engine, causing rapid engine wear.

4. **Muffler** – Used to reduce noise and emissions.
5. **Recoil Starting Handle (pull rope)** – For manual starting method, pull the starter grip until resistance is felt, then pull briskly and smoothly.
6. **Recoil Starter** – Used for manual-starting method.
7. **Oil Filler Cap/Dipstick** – Remove this cap to add oil to the engine crankcase. Read dipstick to determine if oil level is low. Do not overfill.
8. **Oil Drain Plug** – Unscrew plug to drain oil from the engine crankcase. Dispose of oil in a safe manner.
9. **Decompression Lever** – Press down before starting engine. To prevent damage to engine, do not use for any other purpose.
10. **Fuel Cock** – controls the flow of diesel fuel to the carburetor. Must be in the ON position when starting and running the engine.

⚠ WARNING — Hot Components



Engine components can generate extreme heat. To prevent burns, **DO NOT** touch these areas while the engine is running or immediately after operating. **NEVER** operate the engine with the muffler removed.

⚠ CAUTION — Eye and Hearing Hazards



ALWAYS wear approved eye and hearing protection when required.

⚠ WARNING — Lethal Gas Exhaust Hazard



NEVER operate the compactor in a confined area or enclosed area structure that does not provide ample **free flow of air**.

Before Starting

1. Read safety instructions at the beginning of manual.
2. Familiarize yourself with the operating and control elements of the machine and the working environment. This includes obstacles in the working area, bearing capacity of the ground and the necessary safety provisions. 
3. Check the air filter for dirt and dust. If air filter is dirty, replace air filter with a new one as required.
4. Check fastening nuts and bolts for tightness. Loose threads may cause damage to the machine when vibrating.
5. Understand the geographical features and regulations of the job site.
6. Clean the compactor, removing dirt and dust. Particularly, the bottom of the plate, engine cooling air inlet.

Checking Engine Oil Level

1. To check the engine oil level, place the compactor on secure level ground with the engine stopped.
2. Remove the dipstick from the engine oil filler hole (Figure 4) and wipe it clean.
3. Insert and remove the dipstick without screwing it into the filler neck. Check the oil level shown on the dipstick.
4. If the oil level is low (Figure 5), fill to the edge of the oil filler hole with the recommended oil type (Table 4).

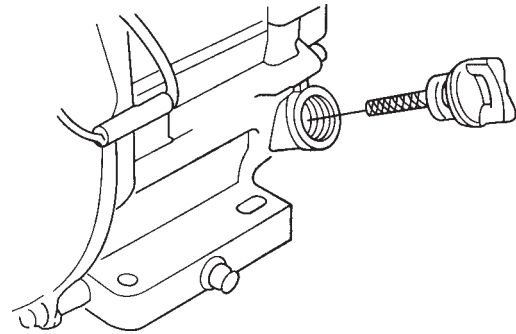

Figure 4. Engine Oil Dipstick Removal

Maximum oil capacity is 1.2 quarts (1.10 liters).

Checking the Hydraulic Oil Level

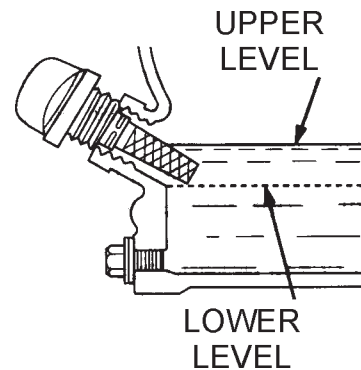

Figure 5. Engine Oil Level

Table 4. Oil Type

Season	Temperature	Oil Type
Summer	25°C or Higher	SAE 10W-30
Spring/Fall	25°C~10°C	SAE 10W-30/20
Winter	0°C or Lower	SAE 10W-10

1. To check the engine oil level, place the compactor on secure level ground with the engine stopped.
2. Remove the hydraulic oil breather cap located at the top of the hydraulic oil tank (Figure 6).
3. Using a 24 mm wrench, remove the hydraulic oil filler plug.

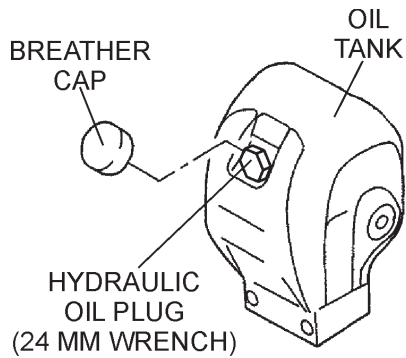

Figure 6. Hydraulic Oil Filler Plug Removal

4. Visually inspect to determine if hydraulic oil level is low. If oil level is low add Shell Tellus 46 hydraulic oil or equivalent through the hand pump oil filler port.

CAUTION — Oil Leaks

DO NOT overfill hydraulic oil tank. This could cause oil leaks and sluggish operation. Clean cap and surrounding area before opening to prevent dirt from entering oil tank.

5. When adding hydraulic oil, only fill to the specified oil level as marked on the front of the hydraulic oil tank (Figure 7). **DO NOT** overfill.



Figure 7. Oil Tank (Front View)

Checking the Air Cleaner

1. Loosen the wing nut and remove the air cleaner cover as shown in Figure 8.
2. Remove the air cleaner element and inspect it for signs of wear or dirt. If air cleaner element is dirty, clean or replace element.

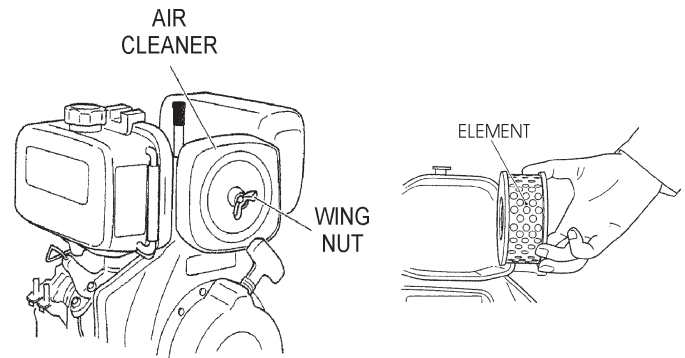

Figure 8. Air Cleaner Element

Checking The Fuel

1. Remove the fuel cap located on top of fuel tank.
2. Visually inspect to see if fuel level is low. If fuel is low, replenish with unleaded gasoline. (Figure 9).
3. When refueling, be sure to use a strainer for filtration. **DO NOT** top-off fuel. Wipe up any spilled fuel.

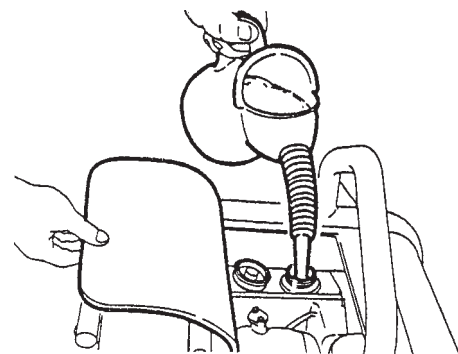

Figure 9. Refueling

DANGER — Fuel Hazard



Adding fuel to the tank should be done only when the engine is stopped and has had an opportunity to cool down. In the event of a fuel spill, **DO NOT** attempt to start the engine until the fuel residue has been completely wiped up and the area surrounding the engine is dry.

RELEASING THE HANDLE

1. Pull the handle release pin, (Figure 10) then push down on the hand grip to release the handle.

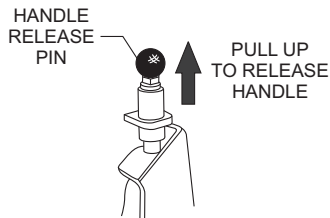
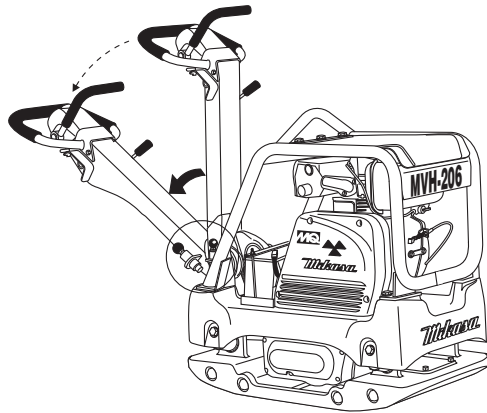

Figure 10. Handle Release Pin

ADJUSTING HANDLE HEIGHT

The height of the handle is adjustable for your comfort.

1. Loosen the butterfly screw (Figure 11).

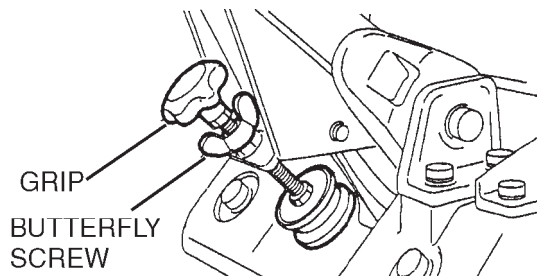

Figure 11. Handle Adjustment

2. Turn the grip clockwise to raise the handle or counterclockwise to lower the handle.
3. When the handle is raised to the desired height, tighten the butterfly screw.

STARTING THE ENGINE

1. Open the fuel cock (Figure 12).

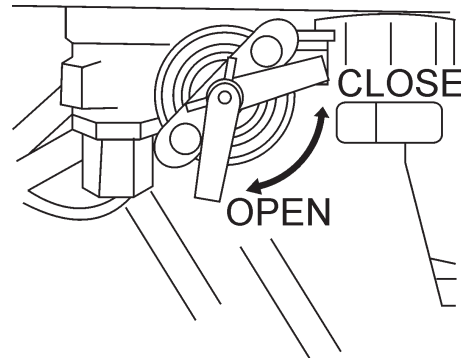

Figure 12. Fuel Cock

2. Move the throttle lever to the **START** position (Figure 13).

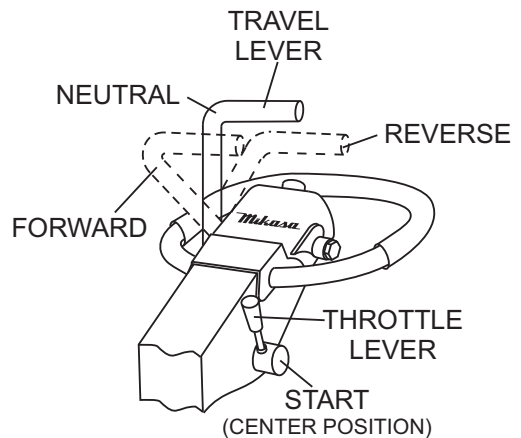

Figure 13. Throttle Lever (START)

3. Grasp the starter grip (Figure 14) and slowly pull it out. The resistance becomes the hardest at a certain position, corresponding to the compression point. Pull the starter grip briskly and smoothly for starting.

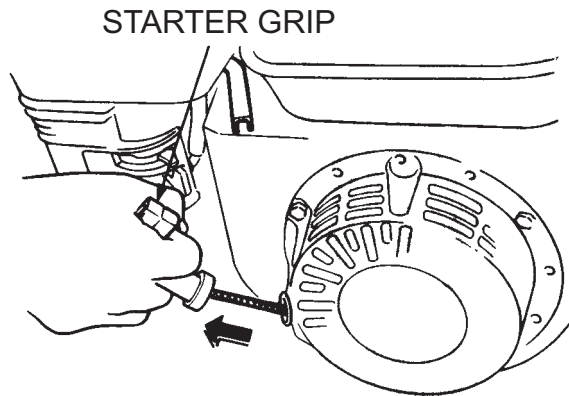

Figure 14. Starter Grip

4. Push the decompression lever (Figure 15) and release.

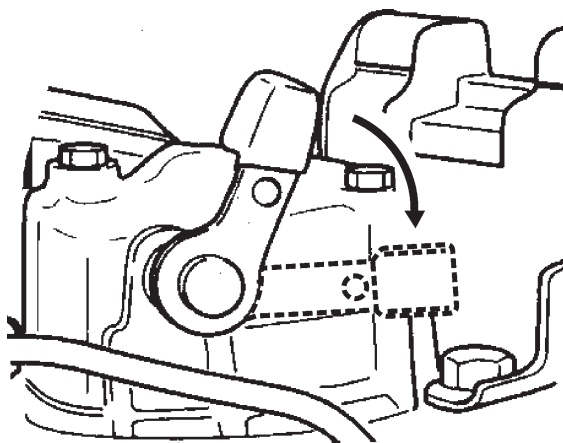

Figure 15. Decompression Lever

TRAVELING

1. Grasp the compactor's hand grip (Figure 16), and move the engine throttle lever quickly to the **fast** position.

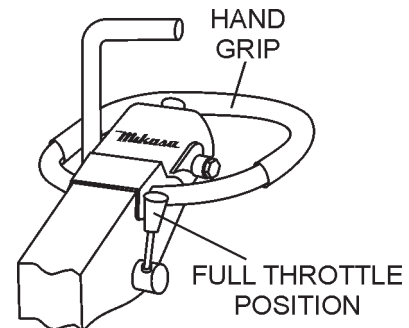
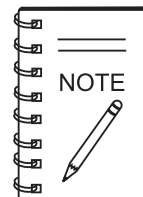

Figure 16. Throttle Lever (FAST)

2. With the throttle lever in the fast position, the engine speed should be around 3,600 RPM, therefore engaging the centrifugal clutch.



ALWAYS move the throttle lever quickly without hesitation, because increasing the engine speed slowly causes the clutch to slip.

3. To make the compactor move in the forward direction push the travel lever (Figure 17) forward.

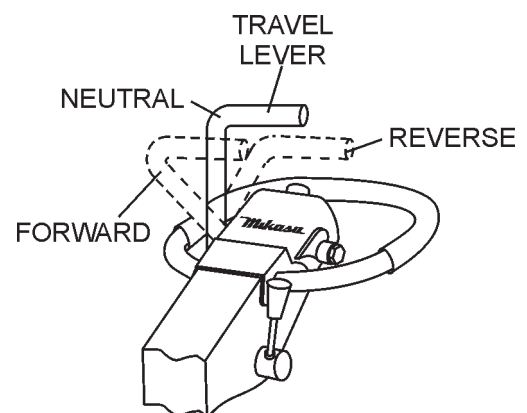

Figure 17. Travel Lever

4. To make the compactor move in the reverse direction pull the travel lever (Figure 17) backwards.

5. Firmly grasp the compactor's hand grip, the compactor will begin moving in the desired position when the direction lever has been placed in the desired position.
6. Slowly walk behind the compactor and be on the lookout for any large objects or foreign matter that might cause damage to the compactor or bodily injury.
7. If travel lever is placed in the neutral position, the machine will vibrate in place.
8. To move the compactor laterally, hold the hand grip firmly and swing compactor. **DO NOT** swing compactor while gripping the travel lever.

NORMAL SHUTDOWN

1. Return the throttle lever to the **START** position (Figure 13). Allow the machine to cool down for 2 to 3 minutes.

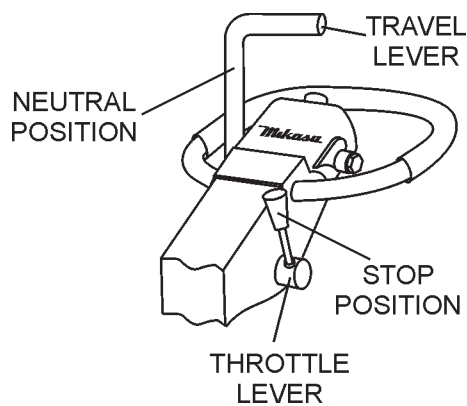

Figure 18. Travel Lever (STOP)

2. Place the travel lever in the **NEUTRAL** position.
3. Place the throttle lever in the **STOP** position (Figure 18) to stop the engine.
4. Close the fuel cock (Figure 12).

EMERGENCY SHUTDOWN

1. For a recoil start type engine, move the throttle lever quickly to the **STOP** position.

STOWING THE HANDLE

1. Push up the handle upward (Figure 19) until the handle locks in place.

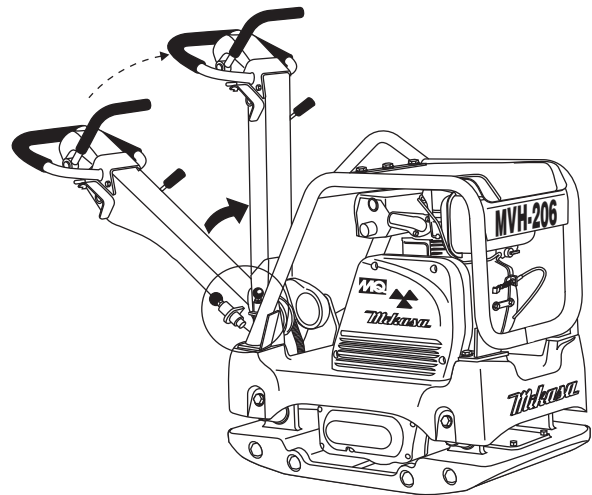

Figure 19. Stowing the Handle

⚠ CAUTION — Inspection Requirements

Inspection and other services should *always* be carried out on hard and level ground with the engine shutdown.

INSPECTION

To make sure your compactor is always in good working condition, perform maintenance inspection in accordance with Tables 5 through 7 before use.

Table 5. MVH-206D Inspection

ITEM	HOURS OF OPERATION
Loose or Missing Screws	Every 8 hours (every day)
Damaged Parts	Every 8 hours (every day)
Function of Controlling System Part	Every 8 hours (every day)
Hydraulic System Leak	Every 100 hours
Vibrator Oil Check	Every 100 hours
Vibrator Oil Replacement	Every 300 hours
Hydraulic Oil Check	Every 100 hours
Hydraulic Oil Replacement	First after 200 hours, then every 1,000 hours
V-belt (clutch) Check	Every 200 hours

⚠ CAUTION — Inspection Intervals

These inspection intervals are for operation under normal conditions. Adjust your inspection intervals based on the number hours plate compactor is in use, and particular working conditions.

⚠ CAUTION — Fuel Piping Replacement

Fuel piping and connections should be replaced every 2 years.

Table 6. MVH-206D Engine Check

Item	Hours of Operation
RPM Check	Every 40 hours (every week)
Oil or Fuel Leak	Every 8 hours (every day)
Tightness of Fastening Threads	Every 8 hours (every day)
Engine Oil Check and Replenishment	Every 8 hours (every day) (Replenish to specified maximum level)
Engine Oil Replacement	After first 25 hours then every 50 to 100 hours
Air Filter Cleaning	Every 100 hours
Engine Valve Adjustment	After first 50 hours then once a year and when required by poor performance thereafter.
See separate engine manual for details on engine check.	

DAILY SERVICE

- Check for leakage of fuel or oil.
- Check for loose screws including tightness. See Table 7 for retightening.

Table 7. Tightening Torque (kg cm)

Material	Diameter							
	6mm	8mm	10mm	12mm	14mm	16mm	18mm	20mm
4T	70	150	300	500	750	1,100	1,400	2,000
6-8T	100	250	500	800	1,300	2,000	2,700	3,800
11T	150	400	800	1,200	2,000	2,900	4,200	5,600
*	100	300~ 350	650 ~ 700					

* (In case counterpart is of aluminum)
(Threads in use with this machine are all right-handed)
Material and quality of material is marked on each bolt and screw.

- Remove soil and clean the bottom of compaction plate.
- Check hand pump, piping and hose for any leakage. A loosened hydraulic hose can be a cause for leakage. Check hydraulic hose connections with wrench applied for tightness.
- Check engine oil.

ENGINE OIL REPLACEMENT

1. Replace engine oil, first in 25 hours of operation and every 50 to 100 hours afterwards.
2. Drain the engine oil when the oil is **warm** as shown in Figure 20.

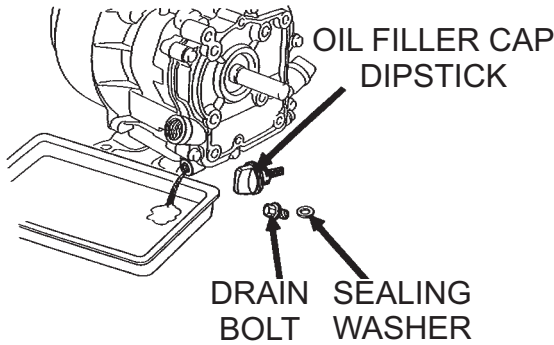

Figure 20. Engine Oil (Draining)

3. Remove the oil drain bolt and sealing washer and allow the oil to drain into a suitable container.
4. Replace engine oil with recommended type oil as listed in Table 4. Engine oil capacity is 1.16 quarts (1.1 liters). **DO NOT** overfill.
5. Install drain bolt with sealing washer and tighten securely.

AIR CLEANER

1. Remove the air cleaner cover and foam filter element as shown in Figure 21.

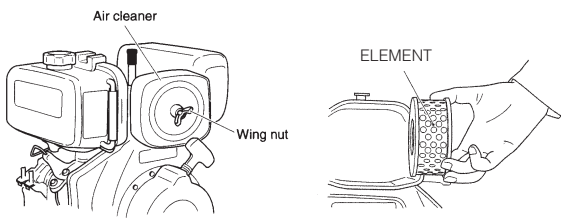

Figure 21. Engine Air Cleaner

3. Clean foam element in warm, soapy water or nonflammable solvent. Rinse and dry thoroughly. Dip the element in clean engine oil and completely squeeze out the excess oil from the element before installing.

CAUTION — V-Belt Hazard

NEVER attempt to check the V-belt with the engine running. Severe injury can occur if your hand gets caught between the belt and clutch (Figure 22). Always wear safety gloves.

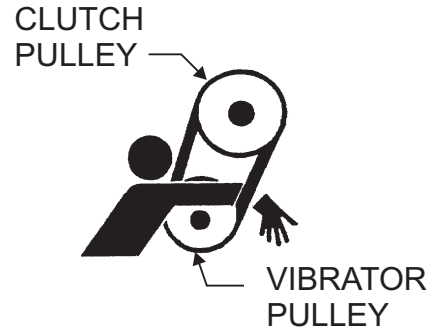

Figure 22. V-Belt Hazard

CHECKING AND REPLACING THE V-BELT AND CLUTCH

After 200 hours of operation, remove the belt cover to check the V-belt tension (Figure 23). Tension is proper if the belt bends about 3/8" (10 mm) when depressed strongly with finger between shafts. Loose or worn V-belts reduce power transmission efficiency, causing weak compaction and reduces the life of the belt itself.

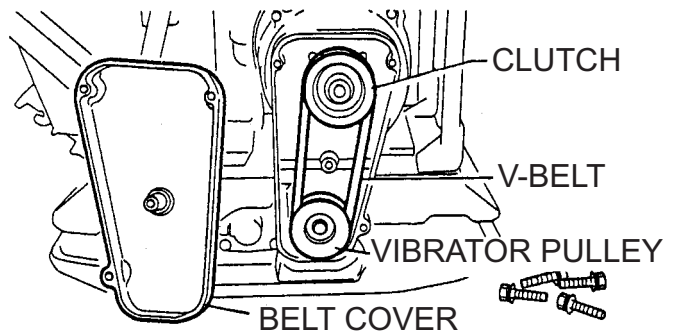

Figure 23. Engine Air Cleaner

Replacing the V-belt

Remove the belt cover. Engage an offset wrench 3/4" (19 mm) or the like to vibrator pulley (lower) fastening bolt. Engage waste cloth or the like at midway of V-belt on the left side and while pulling it back strongly, rotate the offset wrench clockwise so that the V-belt will come off.

Reinstalling the V-belt

Engage V-belt to lower vibrator pulley and push the V-belt to left side of upper clutch and, in the same manner as in removal, rotate offset wrench clockwise so that the V-belt goes back on.

Checking Clutch

Check the clutch simultaneously with V-belt checking. With belt cover removed, check outer drum of the clutch for seizure and "V" groove for wear or damage with your eyes. Clean the "V" groove as necessary. Wear of lining or shoe should be checked with running check. If the shoe is worn, power transmission becomes deficient and slipping will result.

Replacing Clutch

Remove V-belt. Remove bolt at engine power output by giving a shock to an engaged wrench (tapping with hammer or the like) and rotating bolt counterclockwise. Remove clutch with a pulley extractor. To reinstall, reverse the procedure.

CAUTION — Weak Vibration

Whenever the compactor's vibration becomes weak or lost during normal operation regardless of operation hours, check the V-belt and clutch immediately.

VIBRATOR OIL LEVEL CHECK

CAUTION — Dirt and Debris

Always clean the area around the vibrator oil level check plug before removing oil check plug. This will prevent dirt and debris from entering the system.

In every 100 hours of operation, with the machine positioned horizontally, use a 14 mm wrench and remove vibrator oil level check plug (Figure 24). Measure oil level with gauge. Vibrating oil capacity is 0.63 quart (0.6 liters). Be sure to clean area around check hole to prevent dirt and dust from entering.

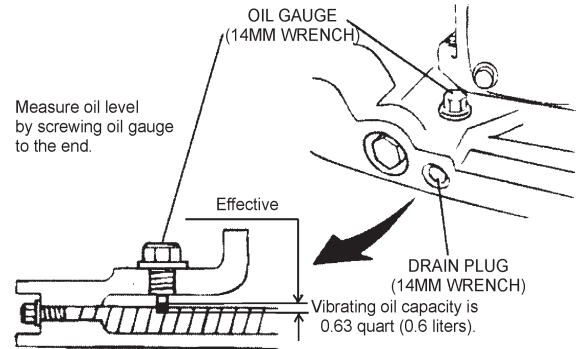

Figure 24. Vibrator Oil Drain and Check Plugs

DRAINING VIBRATOR OIL

1. Replace vibrator oil after first 200 hours and in every 1,000 hours of operation.
2. Position handle bar vertically (storage position).
3. Using a 14 mm wrench remove the vibrator oil drain plug (Figure 24) from the vibrating plate assembly.



For draining oil through level check hole, have the machine inclined with a sleeper or the like placed under the compaction plate on opposite side.

4. After vibrator oil has been completely drained from machine, fill with 10W-30 motor oil to the appropriate safe operating level (Figure 24).
5. Reinstall drain plug into vibrating plate assembly. Apply seal tape or Loctite #575 to thread portion of drain plug.

DRAINING HYDRAULIC OIL

1. Disconnect the hydraulic hose connected to the hydraulic oil cylinder (Figure 25).
2. Push the travel lever back and forth to drain the hydraulic oil from the hand pump (hydraulic oil reservoir).
3. After draining hydraulic oil, reconnect hydraulic oil hose to cylinder.
4. Place handle in upright position. Pull travel lever all the way back (reverse), and using a rope, secure travel lever to hand grip.

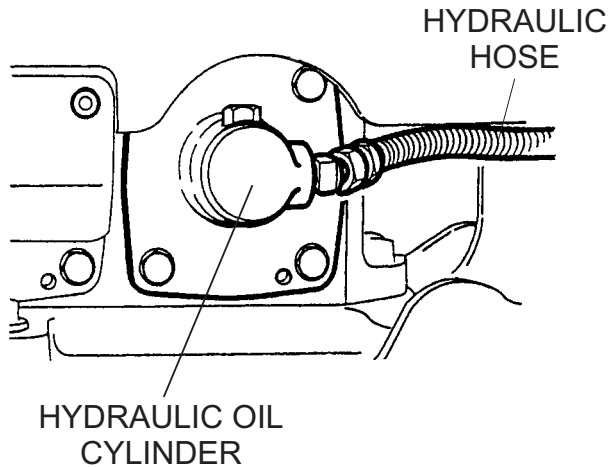

Figure 25. Hydraulic Oil Cylinder

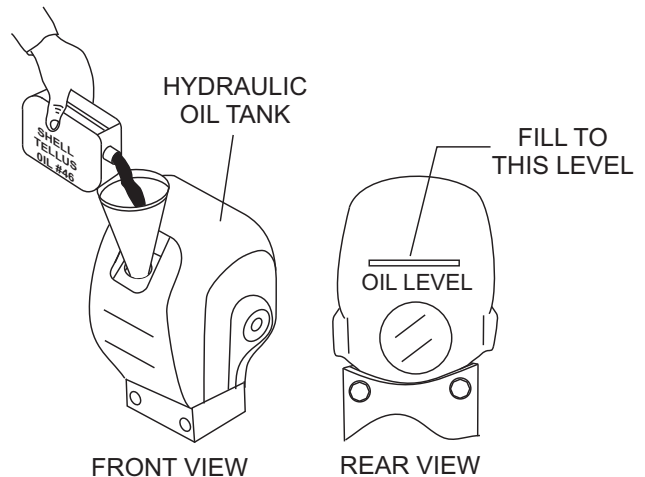

Figure 27. Hydraulic Oil Maintenance

ADDING HYDRAULIC OIL

1. Remove the breather cap and oil plug (Figure 26) from the hydraulic oil tank using a 24mm hex socket.

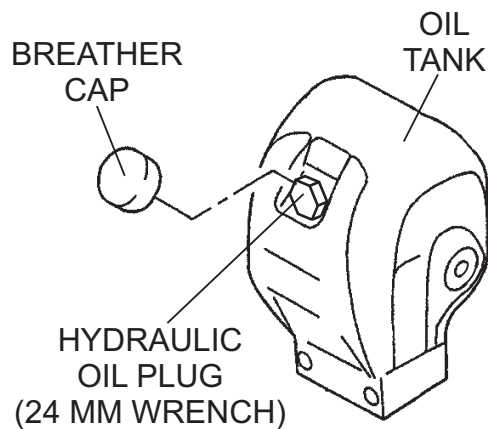

Figure 26. Hydraulic Oil Tank

2. Using a funnel, add **ShellTellus Oil #46** or equivalent to the hydraulic oil tank through the oil filler port (Figure 27). Oil tank capacity is 50.7 fl. oz (1500 cc).

CAUTION — Hydraulic Oil Overfill

Make sure hydraulic oil is at a normal safe operating level. **DO NOT** overfill. Overfilling (excessive oil) will cause excess oil to blow out of breather plug.

3. Loosen bleeder plug located at top of hydraulic cylinder on side of vibrator (Figure 28). Air remaining in the circuit will be forced out of the bleeder plug. Once all air has been purged from the hydraulic system, tighten bleeder plug securely.

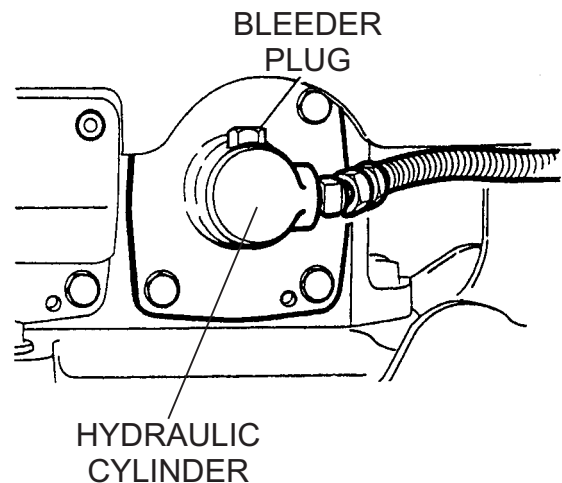

Figure 28. Bleeder Plug

4. Reinsert oil plug into hydraulic oil tank and tighten securely. Reinstall breather cap.

LONG TERM STORAGE

When storing your compactor for long periods do the following:

1. Run the engine at idle speed for 3-5 minutes.
2. Stop the engine. Drain the engine crankcase oil while the engine is still warm. Fill engine crankcase with fresh oil.
3. Wipe any oil or dirt that may have accumulated on the compactor.
4. Store compactor in a cool dry place out of reach of children and unauthorized personnel.

TROUBLESHOOTING (ENGINE)

Practically all breakdowns can be prevented by proper handling and maintenance inspections, but in the event of a breakdown, please take remedial action based on the troubleshooting information shown. If the problem cannot be remedied, please leave the unit as is and consult Multiquip's business office or service plant.

TABLE 8. ENGINE TROUBLESHOOTING

SYMPTOM	POSSIBLE PROBLEM	SOLUTION
Engine will not start or start is delayed, although engine can be turned over.	Speed control lever is in "STOP" position?	Set speed control lever to "START" position.
	No fuel reaching injection pump?	Add fuel. Check entire fuel system.
	Defective fuel pump?	Replace fuel pump.
	Fuel filter clogged?	Replace fuel filter and clean tank.
	Faulty fuel supply line?	Replace or repair fuel line.
	Compression too low?	Check piston, cylinder and valves. Adjust or repair per engine repair manual.
	Fuel injector not working correctly?	Repair or replace injector in accordance with engine repair manual.
	Oil pressure too low?	Check engine oil pressure.
	Low starting temperature limit exceeded	Comply with cold starting instructions and proper oil viscosity.
At low temperatures engine will not start.	Fuel separates has inadequate resistance to low temperatures?	Check whether clear (not turbid) fuel emerges from the fuel line (detach from injection pump). If the fuel is turbid or separated, warm up the engine or drain the complete fuel supply system. Refuel with winter grade diesel fuel.
	Engine oil too thick?	Refill engine crankcase with correct type of oil for winter environment.
Engine fires but stops soon as starter is switched off.	Throttle lever in STOP position?	Reposition throttle lever to RUN position.
	Fuel filter blocked?	Replace fuel filter.
	Fuel supply blocked?	Check the entire fuel system.
Engine stops by itself during normal operation.	Fuel tank empty?	Add fuel.
	Fuel filter blocked?	Replace fuel filter.
Low engine power, output and speed.	Fuel tank empty?	Fill with No.2 diesel fuel.
	Fuel filter clogged?	Replace fuel filter.
	Fuel tank venting is inadequate?	Ensure that tank is adequately vented.
	Speed control lever does not remain in selected position?	See engine manual for corrective action.
	Engine oil level too full?	Correct engine oil level?
Low engine power output and low speed, black exhaust smoke.	Air filter blocked?	Clean or replace air filter.
	Incorrect valve clearances?	Adjust valves per engine specification.
	Malfuction at injector?	See engine manual.

TROUBLESHOOTING (COMPACTOR)

Table 9. Compactor Troubleshooting

Symptom	Possible Cause	Solution
Travel speed low and vibration weak.	Clutch slips?	Adjust or replace clutch.
	V-belt slips?	Adjust or replace V-belt.
	Excessive Oil in vibrator?	Fill to correct level..
	Trouble in vibrator internals?	Check vibrator assembly for any worn or defective parts, replace any defective parts.
	Aeration in hydraulic oil for for travel reversing syste.?	Purge air in hydraulic oil. (Bleed plug)
	Engine speed incorrect?	Set engine speed to correct RPM.
Travels forward or backward but unable to switch direction.	Travel reversing system inoperative.?	Check entire travel system.
	Reversing lever installation correct?	Clean installation of reversing lever.
	Broken or defective oil hose?	Replace oil hose.
	Aeration in hydraulic oil for for travel reversing syste.?	Purge air in hydraulic oil. (Bleed plug)
	Excessive oil in reversing system?	Fill to correct level..
	Selector valve clogged with trash?	Clean selector valve.
	Cylinder piston bearing failure?	Check piston bearing in cylinder for leakage at USH packing.
Does not travel in forward or reverse.	V-belt dis-engaged or slips?	Engage V-belt, adjust or replace.
	Clutch slips?	Adjust clutch, replace if necessary.
	Pump input shat key or adapter key-way damaged?	Replace input shatkey or adapter key-way
	Cylinder piston bearing failure?	Check piston bearing in cylinder for leakage at USH packing.
Reversing lever operating resistance great.	Excessive hydraulic oil?	Fill to correct level.

OPERATION MANUAL

HERE'S HOW TO GET HELP

PLEASE HAVE THE MODEL AND SERIAL
NUMBER ON-HAND WHEN CALLING

UNITED STATES

Multiquip Inc.

(310) 537- 3700
6141 Katella Avenue Suite 200
Cypress, CA 90630
E-MAIL: mq@multiquip.com
WEBSITE: www.multiquip.com

CANADA

Multiquip

(450) 625-2244
4110 Industriel Boul.
Laval, Quebec, Canada H7L 6V3
E-MAIL: infocanada@multiquip.com

UNITED KINGDOM

Multiquip (UK) Limited Head Office

0161 339 2223
Unit 2, Northpoint Industrial Estate,
Globe Lane,
Dukinfield, Cheshire SK16 4UJ
E-MAIL: sales@multiquip.co.uk

© COPYRIGHT 2020, MULTIQUIP INC.

Multiquip Inc, the MQ logo are registered trademarks of Multiquip Inc. and may not be used, reproduced, or altered without written permission. All other trademarks are the property of their respective owners and used with permission.

This manual MUST accompany the equipment at all times. This manual is considered a permanent part of the equipment and should remain with the unit if resold.

The information and specifications included in this publication were in effect at the time of approval for printing. Illustrations, descriptions, references and technical data contained in this manual are for guidance only and may not be considered as binding. Multiquip Inc. reserves the right to discontinue or change specifications, design or the information published in this publication at any time without notice and without incurring any obligations.

Your Local Dealer is:

