

PARTS MANUAL



Mikasa **SERIES**
MODEL MVH508GH
REVERSIBLE PLATE COMPACTOR
(HONDA GX390UT2SCM3 GASOLINE ENGINE)

Revision #2 (09/26/23)

To find the latest revision of this publication or associated operation manual, visit our website at: www.multiquip.com



THIS MANUAL MUST ACCOMPANY THE EQUIPMENT AT ALL TIMES.

TABLE OF CONTENTS

MVH508GH Reversible Plate Compactor

Explanation Of Code In Remarks Column..... 4
Suggested Spare Parts 5

Compactor Component Drawings

Nameplate And Decals Assembly..... 6-7
Vibrating Plate Assembly 8-9
Vibrator Assembly..... 10-11
Base And Engine Assembly..... 12-15
Electric Device Assembly 16-17
Battery Assembly 18-19
Control Assembly..... 20-23
Hand Pump (Exp.) Assembly..... 24-25
Engine Service Parts 26-27

NOTICE
Specifications and part numbers are subject to change without notice.

EXPLANATION OF CODE IN REMARKS COLUMN

The following section explains the different symbols and remarks used in the Parts section of this manual. Use the help numbers found on the back page of the manual if there are any questions.

NOTICE

The contents and part numbers listed in the parts section are subject to change without notice. Multiquip does not guarantee the availability of the parts listed.

SAMPLE PARTS LIST

NO.	PART NO.	PART NAME	QTY.	REMARKS
1	12345	BOLT	1	INCLUDES ITEMS W/%
2%		WASHER, 1/4 IN.		NOT SOLD SEPARATELY
2%	12347	WASHER, 3/8 IN. ...	1	MQ-45T ONLY
3	12348	HOSE	A/R	MAKE LOCALLY
4	12349	BEARING	1	S/N 2345B AND ABOVE

NO. Column

Unique Symbols — All items with same unique symbol (@, #, +, %, or >) in the number column belong to the same assembly or kit, which is indicated by a note in the “Remarks” column.

Duplicate Item Numbers — Duplicate numbers indicate multiple part numbers, which are in effect for the same general item, such as different size saw blade guards in use or a part that has been updated on newer versions of the same machine.

NOTICE

When ordering a part that has more than one item number listed, check the remarks column for help in determining the proper part to order.

PART NO. Column

Numbers Used — Part numbers can be indicated by a number, a blank entry, or TBD.

TBD (To Be Determined) is generally used to show a part that has not been assigned a formal part number at the time of publication.

A blank entry generally indicates that the item is not sold separately or is not sold by Multiquip. Other entries will be clarified in the “Remarks” Column.

QTY. Column

Numbers Used — Item quantity can be indicated by a number, a blank entry, or A/R.

A/R (As Required) is generally used for hoses or other parts that are sold in bulk and cut to length.

A blank entry generally indicates that the item is not sold separately. Other entries will be clarified in the “Remarks” Column.

REMARKS Column

Some of the most common notes found in the “Remarks” Column are listed below. Other additional notes needed to describe the item can also be shown.

Assembly/Kit — All items on the parts list with the same unique symbol will be included when this item is purchased.

Indicated by:

“INCLUDES ITEMS W/(unique symbol)”

Serial Number Break — Used to list an effective serial number range where a particular part is used.

Indicated by:

“S/N XXXXX AND BELOW”

“S/N XXXX AND ABOVE”

“S/N XXXX TO S/N XXX”

Specific Model Number Use — Indicates that the part is used only with the specific model number or model number variant listed. It can also be used to show a part is NOT used on a specific model or model number variant.

Indicated by:

“XXXXX ONLY”

“NOT USED ON XXXX”

“Make/Obtain Locally” — Indicates that the part can be purchased at any hardware shop or made out of available items. Examples include battery cables, shims, and certain washers and nuts.

“Not Sold Separately” — Indicates that an item cannot be purchased as a separate item and is either part of an assembly/kit that can be purchased, or is not available for sale through Multiquip.

SUGGESTED SPARE PARTS

MVH508GH PLATE COMPACTOR WITH GX390UT2SCM3 HONDA ENGINE

1 to 3 units

Qty.	P/N	Description
2	070200463	V-BELT
4	939010010	SHOCK ABSORB., STOP
1	16910GB2005	FUEL FILTER
4	939010380	SHOCK ABSORBER
1	956100070	THROTTLE WIRE
1	35100768S01	SWITCH ASSY., COMBINATIION
1	35110736612	KEY ASSY.
3	0650140480	SPARK PLUG, (BPR6ES)
1	28462ZE3W01	ROPE, RECOIL STARTER
3	17210Z1C781	ELEMENT, AIR CLEANER
3	17218Z1C780	FILTER, OUTER
1	17620Z4H900	CAP, FUEL TANK
1	17672Z4H000	FUEL FILTER, FUEL TANK

NOTICE

Part numbers on this Suggested Spare Parts list may supersede/replace the part numbers shown in the following parts lists.

NAMEPLATE AND DECALS ASSY.

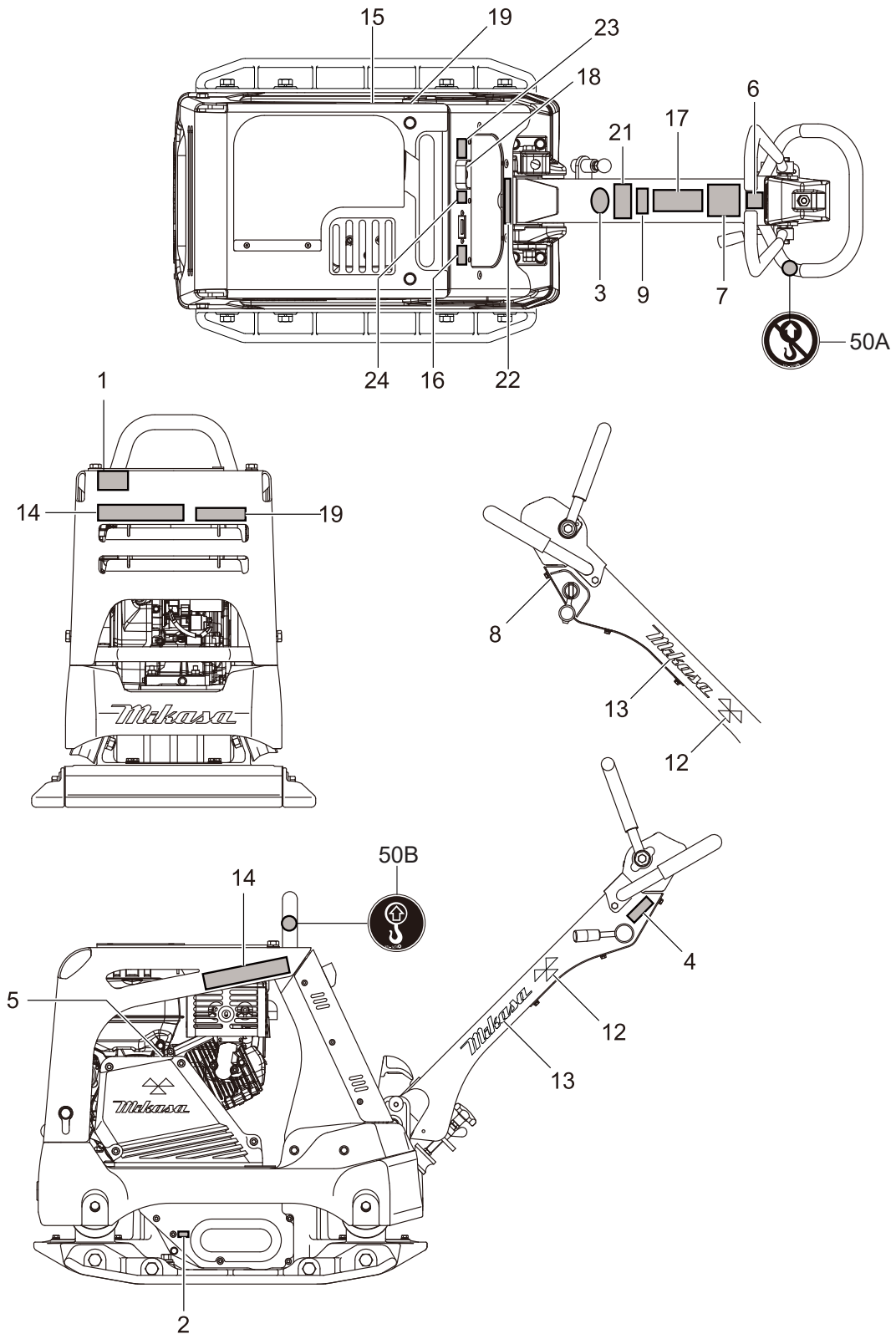

NAMEPLATE AND DECALS ASSY.

<u>NO.</u>	<u>PART NO.</u>	<u>PART NAME</u>	<u>QTY.</u>	<u>REMARKS</u>
1	920201580	DECAL: MQ MARK 71X55	1	
2	920201950	DECAL: OIL SAE 10W-30	1	
3	920222810	EAR PROTECTION LABEL	1	
4	920204580	DECAL: FULL THROTTLE	1	
5	920217690	DECAL: V-BELT HDPF-5460	1	
6	920210310	DECAL: EC NOISE REQ.LWA107	1	
7	920211060	DECAL: CAUTION (LEVER)	1	
8	920211090	DECAL: SHELL TELLUS OIL 32	1	
9	920214100	DECAL: E/G FIRE WARNING	1	
12	920217110	DECAL: MIKASA MARK 35X70	2	
13	920217130	DECAL: MIKASA MARK (W) 200L	2	
14	920217810	DECAL: MODEL (R)	1	
15	920217820	DECAL: MODEL (L)	1	
16	920218130	DECAL: E/G RPM 3600	1	
17	920218390	DECAL: CAUTION	1	
18	920106760	DECAL: STOP-RUN-START	1	
21	920222240	DECAL: PROPOSITION 65	1	
22	920216610	DECAL: CAUTION (FOR WASHING)	1	
23	920214950	DECAL: REMOVE KEY	1	
24	920214960	DECAL: KEY OPERATION	1	
50A	920900110	DECAL: SET, DO NOT LIFT	1	
50B	920900110	DECAL: SET, LIFT POINT	1	

VIBRATING PLATE ASSY.

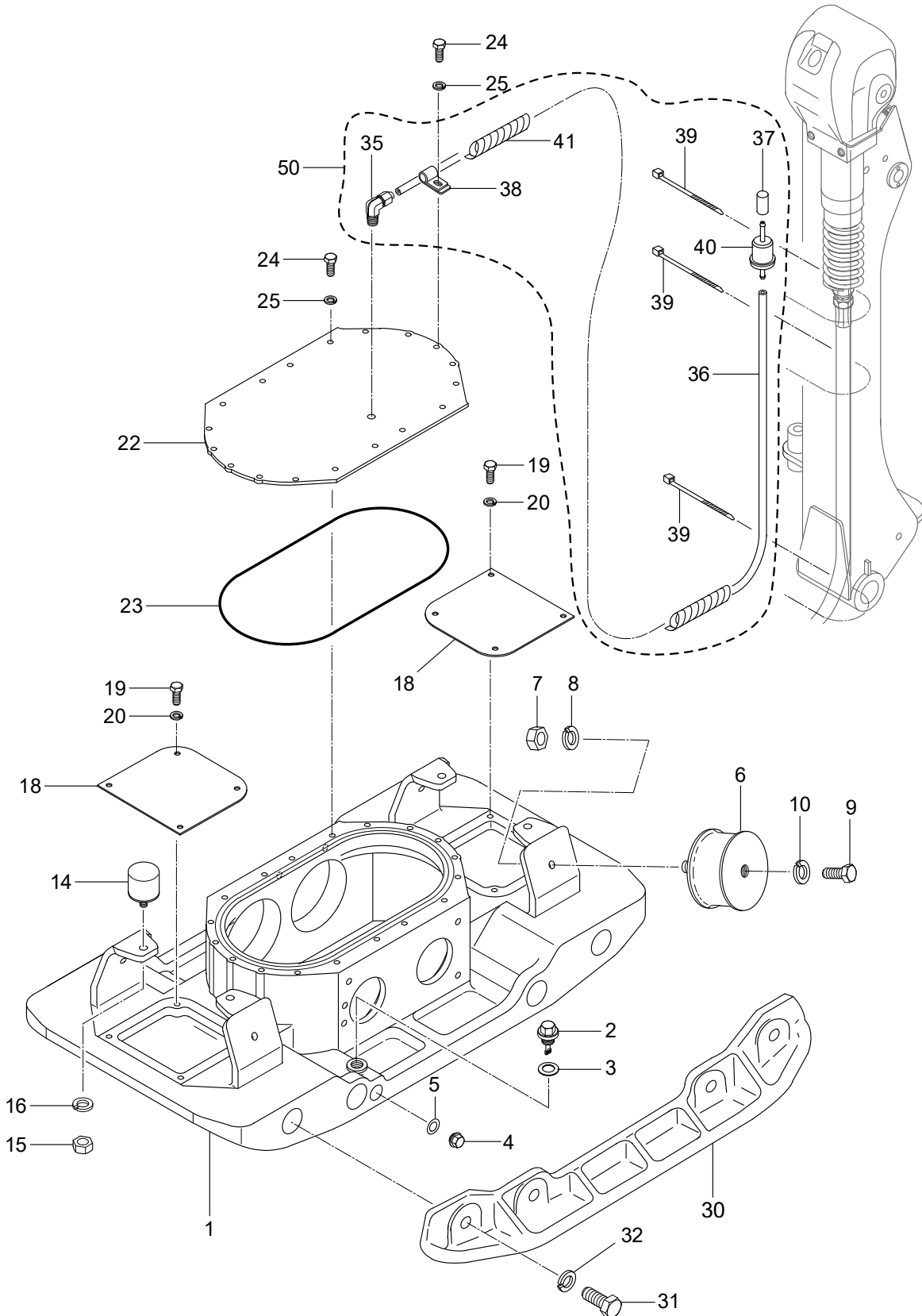

VIBRATING PLATE ASSY.

<u>NO.</u>	<u>PART NO.</u>	<u>PART NAME</u>	<u>QTY.</u>	<u>REMARKS</u>
1	468121201	VIBRATING PLATE	1	
2	465460670	OIL GAUGE	1	
3	953402930	COPPER PACKING	1	
4	953400270	PLUG 1/4X14 10L	1	
5	953405260	PACKING 1/4 (CU)	1	
6	939010380	SHOCK ABSORBER	4	
7	020316130	NUT M16	4	
8	030216400	WASHER, LOCK M16	4	
9	001221635	BOLT 16X35	4	
10	030216400	WASHER, LOCK M16	4	
14	939010010	SHOCK ABSORBER, STOPPER	4	
15	020310080	NUT M10	4	
16	030210250	WASHER, LOCK M10	4	
18	468352110	COVER, VIBRATOR, PLATE	2	
19	014208020	BOLT 8X20	8.....	REPLACES P/N 001220820
20	030208200	WASHER, LOCK M8	8	
22	467355940	COVER, VIBRATOR, BREATHER.....	1.....	S/N G10296 AND BELOW
22	467351790	COVER, VIBRATOR	1.....	S/N G10297 AND ABOVE
23	050103250	O-RING	1	
24	014208020	BOLT 8X20	18.....	REPLACES P/N 001220820
25	030208200	WASHER, LOCK M8	18	
30	452990	EXTENSION PLATE	2.....	REPLACES P/N 467219050
31	012218050	BOLT 18X50	8.....	REPLACES P/N 001221850
32	58407	WASHER, LOCK M18.....	8.....	REPLACES P/N 030218460
35\$	954410070	CONNECTOR, TUBE PT 1/8.....	1.....	S/N G10296 AND BELOW
36\$	959029209	NYLON TUBE 6X8X1000	1.....	S/N G10296 AND BELOW
37\$	467471710	BREATHER ELEMENT	1.....	S/N G10296 AND BELOW
38\$	959408920	CLIP 8 (M8)	1.....	S/N G10296 AND BELOW
39\$	507010110A	CLAMP.....	3.....	REPLACES P/N 507010110 S/N G10296 AND BELOW
40\$	16910GB2005	FUEL FILTER	1.....	S/N G10296 AND BELOW
41\$	959021810	SPIRAL TUBE.....	1.....	S/N G10296 AND BELOW
50	469910040	AIR BREATHER TUBE	1.....	INCLUDES ITEMS W/\$ S/N G10296 AND BELOW

VIBRATOR ASSY.

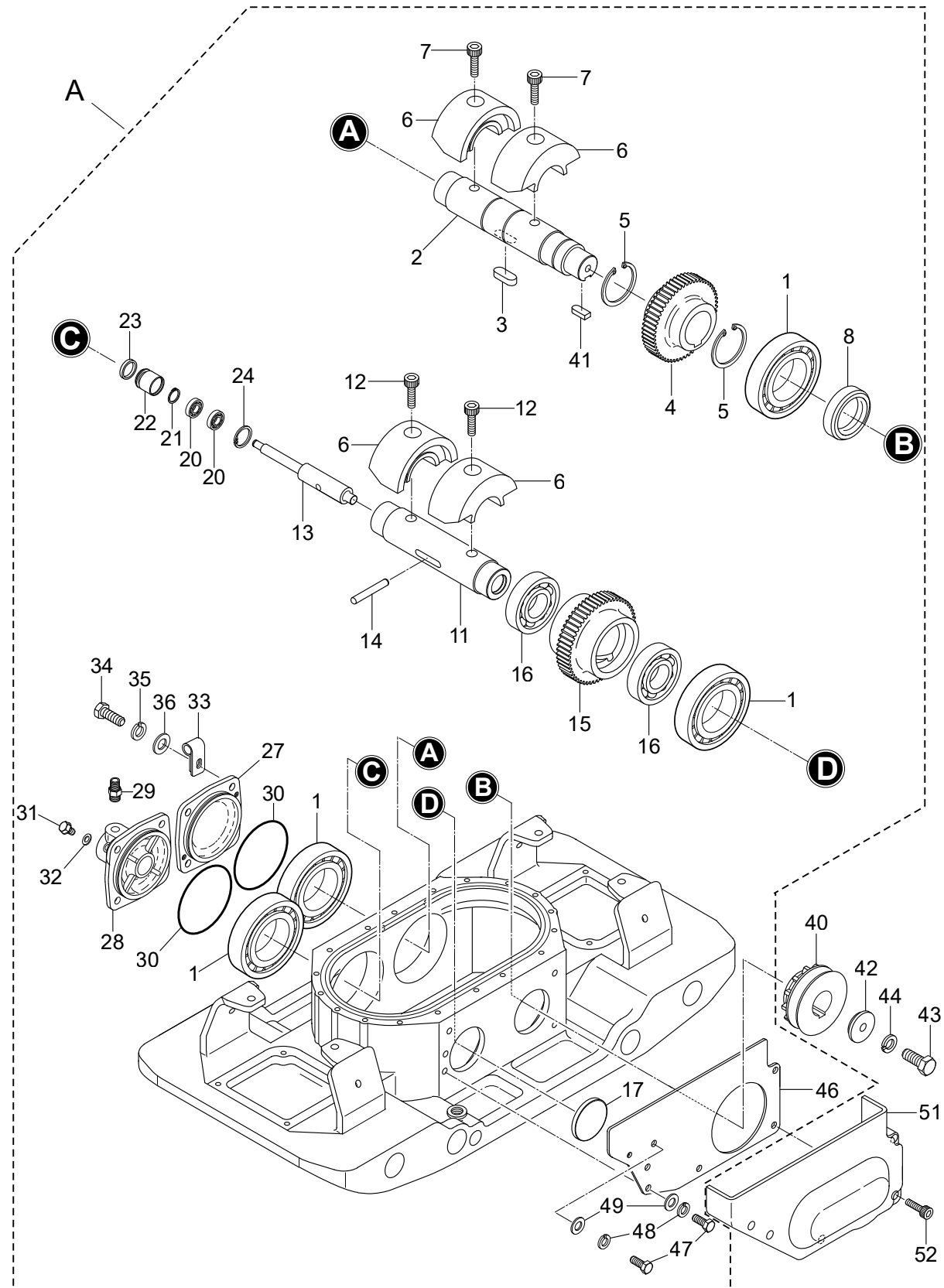

VIBRATOR ASSY.

<u>NO.</u>	<u>PART NO.</u>	<u>PART NAME</u>	<u>QTY.</u>	<u>REMARKS</u>
A	474910010	VIBRATING PLATE ASSY.....	1.....	INCLUDES ITEMS W/\$ S/N G10296 AND BELOW
A	469910033	VIBRATING PLATE ASSY.....	1.....	INCLUDES ITEMS W/# S/N G10297 AND ABOVE
1\$#	047920120	ROLLER BEARING	4	
2\$	467355910	ROTARY SHAFT, DRIVE	1.....	S/N G10296 AND BELOW
2\$#	467910070	ROTARY SHAFT, DRIVE	1.....	S/N G10297 AND ABOVE
3\$#	951405370	KEY 15X10X39 RR	1	
4\$#	456327150	GEAR, DRIVE	1	
5\$#	080200550	STOP RING	2	
6\$#	474357530	ECCENTRIC ROTATOR	4	
7\$#	009120301	SOCKET HEAD BOLT 16X40	2	
8\$#	060405040	OIL SEAL TC-50729	1	
11\$#	456337670	SHAFT, ROTARY DRIVEN	1	
12\$#	009120302	SOCKET HEAD BOLT 16X30	2	
13\$#	456337380	PISTON ROD	1	
14\$#	456010010	KNOCK PIN 10X70	1	
15\$#	467351910	GEAR (DRIVEN)	1	
16\$#	040006911	BEARING	2	
17\$#	953010030	SEAL CAP	1	
20\$#	042006000	BEARING.....	2.....	REPLACES P/N 042506000
21\$#	0080000010	STOP RING	1.....	REPLACES P/N 080200100
22\$#	455435051	PISTON	1	
23\$#	455010070	PACKING	1	
24\$#	080100260	STOP RING	1	
27\$#	467352540	BEARING COVER	1	
28\$#	467220410	CYLINDER	1	
29\$#	954010020	CONNECTOR PT, PF1/4	1	
30\$#	050101050	O-RING	2	
31\$#	001720812	FLANGE BOLT 8X12	1	
32\$#	953404600	COPPER PACKING	1	
33\$#	959408880	CLIP 15 (M10)	1	
34\$#	0105091025	BOLT 10X25	8.....	REPLACES P/N 001221025
35\$#	030210250	WASHER, LOCK M10	8	
36\$#	031110160	WASHER, FLAT M10	8	
40	474357520	PULLEY	1	
41\$#	951404970	KEY 12X8X30 R	1	
42	456437920	WASHER, PULLEY.....	1.....	S/N G10296 AND BELOW
42	468474700	WASHER, PULLEY.....	1.....	S/N G10297 AND ABOVE
43	012212035	BOLT 12X35	1.....	REPLACES P/N 001221235
44	030212300	WASHER, LOCK M12	1	
46\$#	467351920	GUIDE, BELT COVER	1	
47\$#	014208020	BOLT 8X20	2.....	REPLACES P/N 001220820
48\$#	030208200	WASHER, LOCK M8	2	
49\$#	0401450080	WASHER, FLAT M8.....	2.....	REPLACES P/N 031108160
51	468218962	BELT COVER, LOWER	1	
52	001520856	SOCKET HEAD BOLT 8X80	5	

BASE AND ENGINE ASSY.

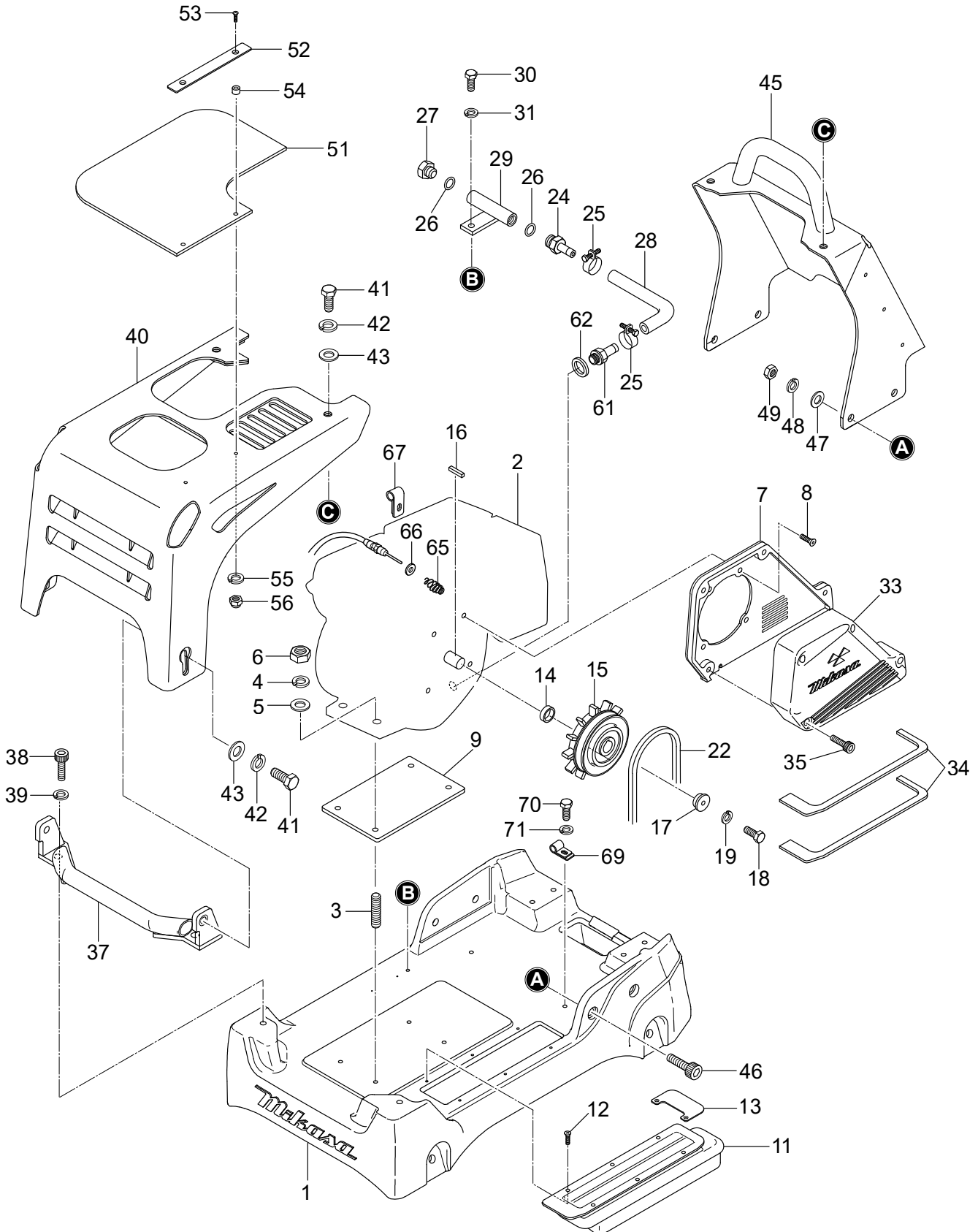

BASE AND ENGINE ASSY.

<u>NO.</u>	<u>PART NO.</u>	<u>PART NAME</u>	<u>QTY.</u>	<u>REMARKS</u>
1	474123000	BASE	1	
2	912239027	ENGINE ASSY., GX390	1	
3	009120207	STUD BOLT 10X55	4	
4	030210250	WASHER, LOCK M10	4	
5	031110160	WASHER, FLAT M10	4	
6	020310080	NUT M10	4	
7	474357500	BELT COVER, IN	1	
8	009110071	SOCKET HEAD BOLT 10X25	4	
9	474357510	ENGINE SPACER	1	
11	468352120	DUST COVER	1	
12	092006010	FLAT HEAD SCREW 6X10	6	
13	468467050	PLATE, BELT COVER	1	
14	952408810	SPACER	1	
15	456343340	CLUTCH ASSY.	1	
16	951400110	KEY 7X7X35	1	
17	952400690	WASHER 9X35X4.5	1	
18	011208030	BOLT 8X30	1	REPLACES P/N 001220830
19	030208200	WASHER, LOCK M8	1	
22	070200463	V-BELT, HDPF-5460	1	
24	2556390111	UNION, DRAIN	1	REPLACES P/N 954407310
25	954410140	HOSE CLAMP	2	
26	953410290	GASKET	2	
27	953410280	PLUG	1	
28	465459390	DRAIN HOSE	1	
29	464457380	DRAIN JOINT	1	
30	014208020	BOLT 8X20	1	REPLACES P/N 001220820
31	030208200	WASHER, LOCK M8	1	
33	467121100	BELT COVER (OUT)	1	
34	467351800	DUST SPONGE (OUT)	2	
35	001521054	SOCKET HEAD BOLT 10X70	4	
37	468352140	FRONT BUMPER	1	
38	001521435	SOCKET HEAD BOLT 14X35	2	
39	030214350	WASHER, LOCK M14	2	
40	468121230	FRONT COVER	1	
41	001221435	BOLT 14X35	4	
42	030214350	WASHER, LOCK M14	4	
43	031114260	WASHER, FLAT M14	4	
45	474123040	CENTER COVER	1	
46	001521435	SOCKET HEAD BOLT 14X35	4	
47	031114260	WASHER, FLAT M14	4	
48	030214350	WASHER, LOCK M14	4	
49	020314110	NUT M14	4	

BASE AND ENGINE ASSY. (CONT'D.)

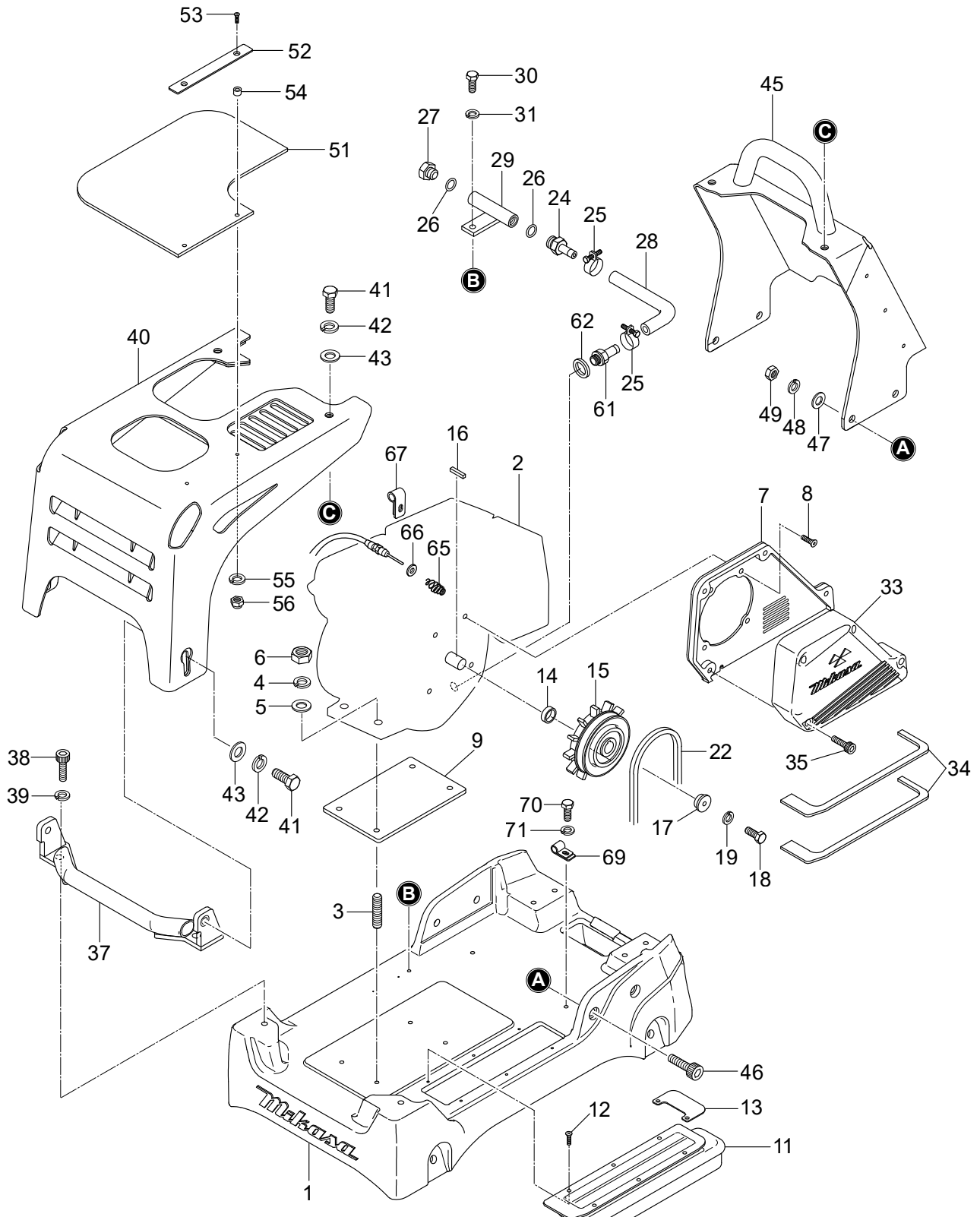

BASE AND ENGINE ASSY. (CONT'D.)

<u>NO.</u>	<u>PART NO.</u>	<u>PART NAME</u>	<u>QTY.</u>	<u>REMARKS</u>
51	467466800	RUBBER COVER, UPPER	1	
52	467466810	STOPPER, COVER	1	
53	009120424	SOCKET HEAD BOLT 6X25	2	
54	617465130	COLLAR	2	
55	030206150	WASHER, LOCK M6	2	
56	022710607	NYLON NUT M6	2	
61	90131ZE3790	DRAIN JOINT	1	
62	031112230	WASHER, DRAIN PLUG M12	1.....	REPLACES P/N 9410912000
65	371467760	RETURN SPRING	1	
66	58151	WASHER, FLAT M5.....	1.....	REPLACES P/N 031105080
67	954410020	CLAMP	1	

ELECTRIC DEVICE ASSY.

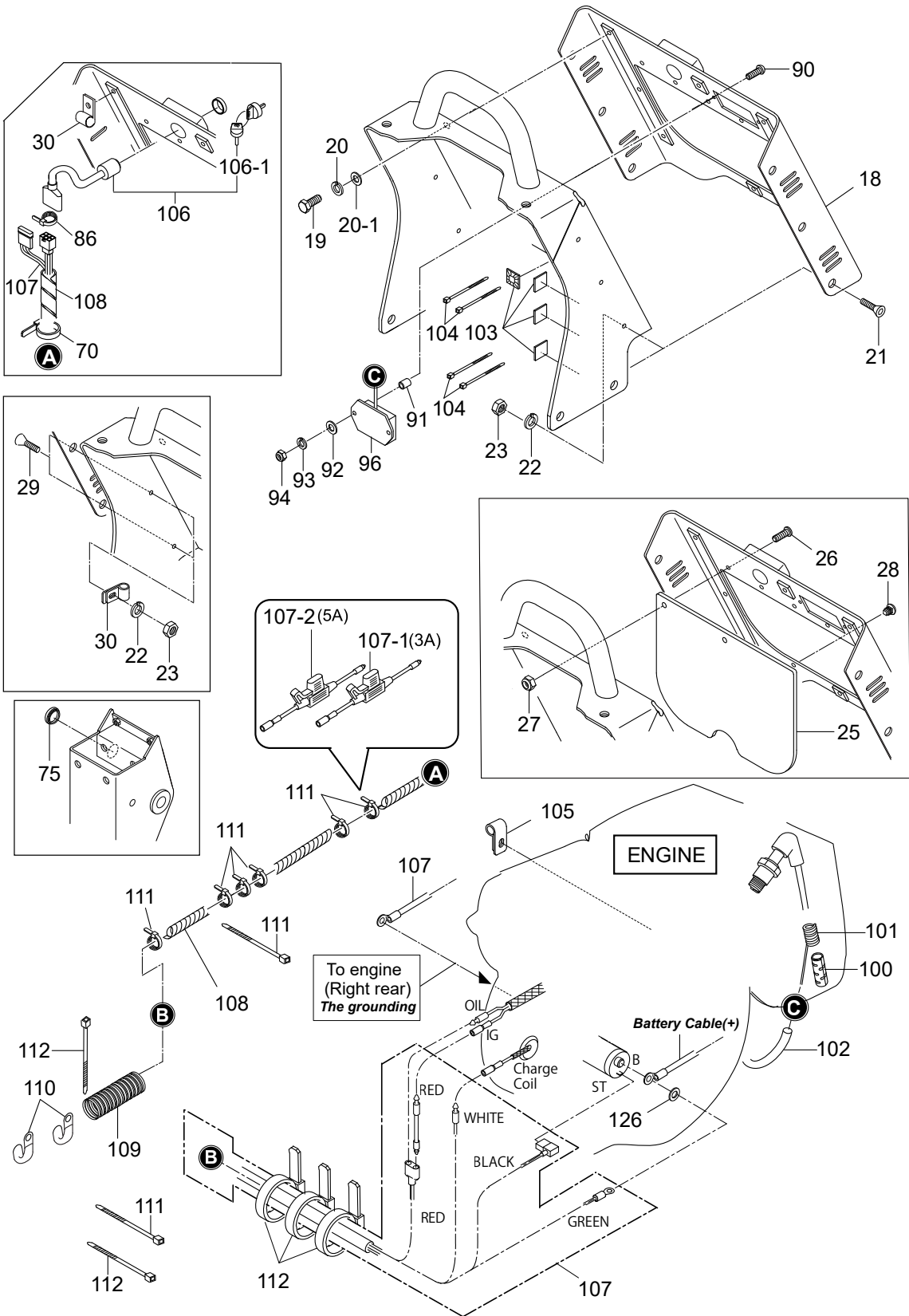

ELECTRIC DEVICE ASSY.

<u>NO.</u>	<u>PART NO.</u>	<u>PART NAME</u>	<u>QTY.</u>	<u>REMARKS</u>
18	474220440	REAR COVER	1	
19	001220612	BOLT 6X12	8	
20	030206150	WASHER, LOCK M6	8	
20-1	952404470	WASHER, FLAT M6.....	8.....	REPLACES P/N 031106100
21	009120413	SUNK HEAD BOLT 6X15	4	
22	030206150	WASHER, LOCK M6	6	
23	020106050	NUT M6.....	6.....	REPLACES P/N 020306050
25	474473910	RUBBER COVER, REAR	1	
26	009110062	SOCKET HEAD SCREW 6X20	3	
27	022710607	NYLON NUT M6	3	
28	009110062	SOCKET HEAD SCREW 6X20	4	
29	009120414	SUNK HEAD BOLT 6X20	2	
30	959408930	CLIP 15 (M6)	3	
70	506010070	CLAMP	6	
75	515010070	GROMMET	1.....	REPLACES P/N 953406090
86	507010110A	CLAMP.....	5.....	REPLACES P/N 507010110
90	009110072	PAN HEAD SCREW 5X35	2	
91	952407930	COLLAR 6X10X13.5	2	
92	58151	WASHER, FLAT M5.....	2.....	REPLACES P/N 031105080
93	030205130	WASHER, LOCK M5	2	
94	022710506	NYLON NUT M5	2	
96	955010311	TACHO/HOUR METER	1	
100	955010307	CLIP BELT	1	
101	955010308	CURL CORD	1	
102	959026828	RUBBER TUBE	1	
103	955407970	WIRING FIXED BASE	4	
104	506010070	CLAMP	4	
105	954410020	CLAMP	1	
106	35100768S01	SWITCH ASSY.,COMBINATION	1	
106-1	35110736612	KEY ASSY.	2	
107	474357560	WIRE HARNESS ASSY.	1	
107-1	474010010	FUSE (3A)	1	
107-2	471010020	FUSE (5A-SMALL)	1	
108	955404270	SPIRAL TUBE	1	
109	959026028	CORRUGATE TUBE	1	
110	954410260	HOSE CLAMP	2	
111	454010020	CLAMP	6	
112	507010110A	CLAMP.....	13.....	REPLACES P/N 507010110
126	952410790	SPACER (BRASS) 6.4X8X2	1	

BATTERY ASSY.

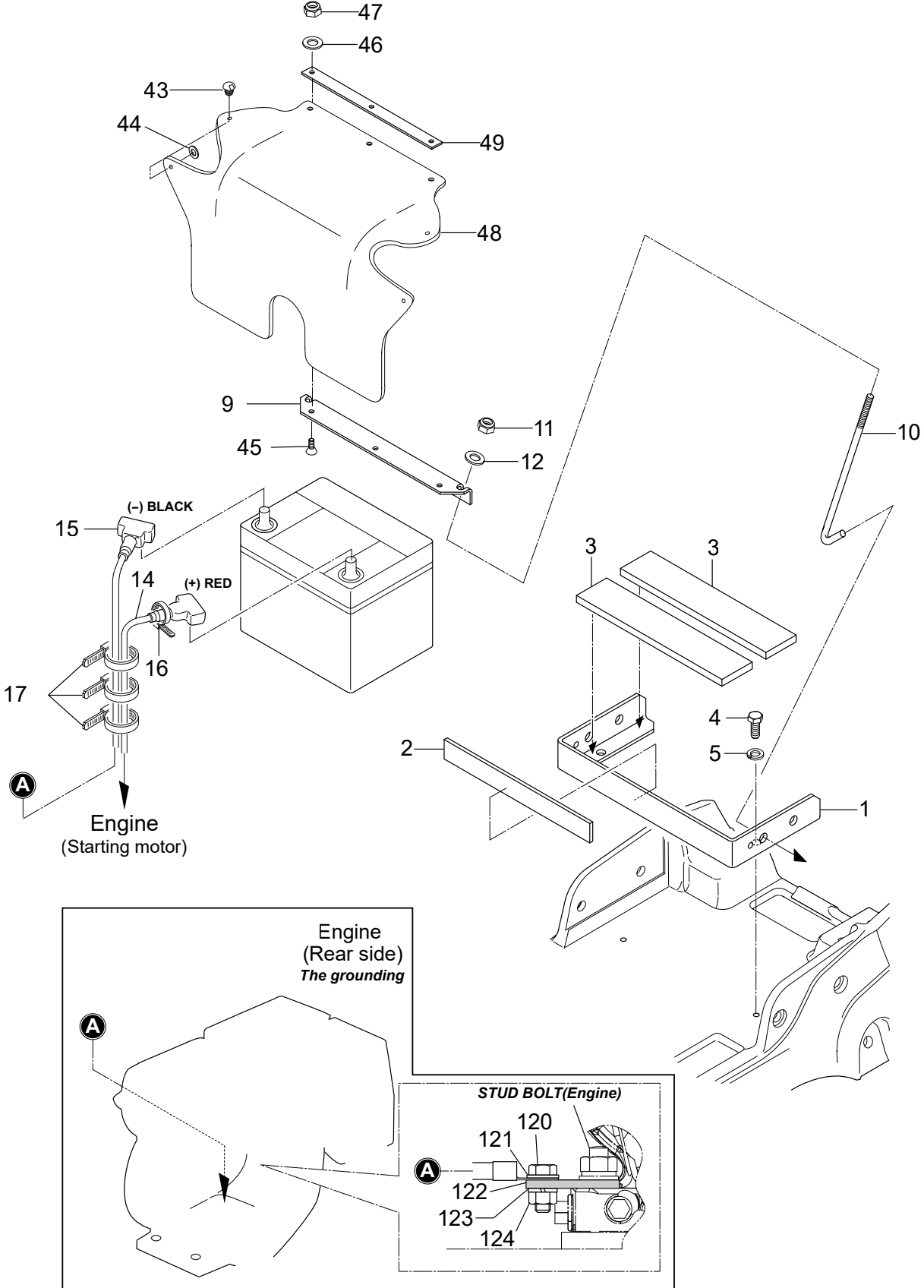

BATTERY ASSY.

<u>NO.</u>	<u>PART NO.</u>	<u>PART NAME</u>	<u>QTY.</u>	<u>REMARKS</u>
1	467218920	BATTERY HOLDER	1	
2	456447590	RUBBER PLATE (E) 28X240X5	1	
3	456447600	RUBBER PLATE 50X240X10	2	
4	012210020	BOLT 10X20	2	REPLACES P/N 001221020
5	030210250	WASHER, LOCK M10	2	
9	474357550	HOLDER, BATTERY	1	
10	469467170	BOLT, BATTERY	2	
11	022710809	NYLON NUT M8	2	
12	0401450080	WASHER, FLAT M8.....	2	REPLACES P/N 031108160
14	955301030	BATTERY CABLE (+)	1	
15	955301040	BATTERY CABLE (-)	1	
16	506010070	CLAMP	2	
17	507010110A	CLAMP.....	3	REPLACES P/N 507010110
43	953409110	BRUSH CLIP	2	
44	952404470	WASHER, FLAT M6.....	2	REPLACES P/N 031106100
45	009120422	SOCKET HEAD BOLT 5X20	3	
46	030205130	WASHER, LOCK M5	3	
47	022710506	NYLON NUT M5	3	
48	474357540	RUBBER PLATE, BATTERY	1	
49	474473890	STOPPER, RUB-PLATE	1	
120	014208020	BOLT 8X20	1	REPLACES P/N 001220820
121	0401450080	WASHER, FLAT M8.....	1	REPLACES P/N 031108160
122	474474330	EARTH STAY	1	
123	030208200	WASHER, LOCK M8	1	
124	020108060	NUT M8.....	1	REPLACES P/N 020308060

CONTROL ASSY.

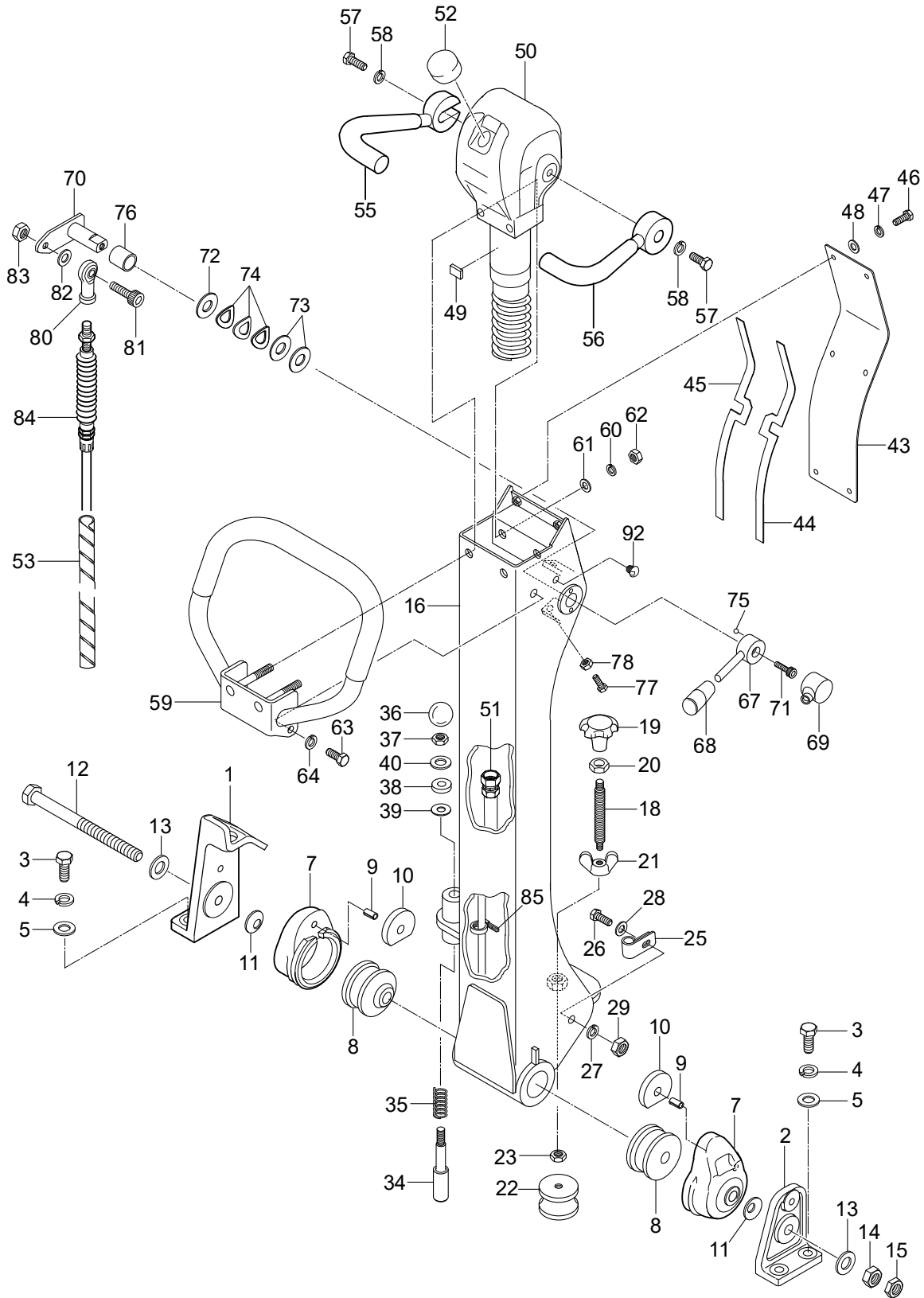

CONTROL ASSY.

<u>NO.</u>	<u>PART NO.</u>	<u>PART NAME</u>	<u>QTY.</u>	<u>REMARKS</u>
1	467351951	HANDLE BRACKET(R)	1	
2	467351960	HANDLE BRACKET(L)	1	
3	012212035	BOLT 12X35	4	REPLACES P/N 001221235
4	030212300	WASHER, LOCK M12	4	
5	031112230	WASHER, FLAT M12	4	
7	456336400	RUBBER COUPLING	2	
8	456449940	SHOCK ABSORBER	2	
9	025306016	SPRING PIN 6X16.....	2	REPLACES P/N 025406016
10	456449930	RUBBER PLATE	2	
11	032124400	CONICAL SPRING WASHER M24	2	
12	001221681	BOLT 16X250	1	
13	0401450160	WASHER, FLAT M16.....	2	REPLACES P/N 031116260
14	020316130	NUT M16	1	
15	020416100	NUT M16	1	
16	467121180	HANDLE BAR	1	
18	455434950	SPINDLE	1	
19	455010030	KNOB	1	
20	020412070	NUT M12	1	
21	022411635	WING NUT M16	1	
22	939010060	SHOCK ABSORBER	1	
23	020310080	NUT M10.....	1	REPLACES P/N 020410060
25	959408930	CLIP 15 (M6)	1	
26	011206020	BOLT 6X20	1	REPLACES P/N 001220620
27	030206150	WASHER, LOCK M6	1	
28	952404470	WASHER, FLAT M6.....	1	REPLACES P/N 031106100
29	020106050	NUT M6.....	1	REPLACES P/N 020306050
34	501402870	HANDLE STOPPER	1	
35	501402880	SPRING HANDLE	1	
36	959403460	BALL GRIP	1	
37	020310080	NUT M10.....	1	REPLACES P/N 020410060
38	456449980	RUBBER PACKING	1	
39	953405260	PACKING 1/4 (CU)	1	
40	031110160	WASHER, FLAT M10	1	
43	467351980	HANDLE COVER	1	
44	467467340	PACKING (L), HANDLE	1	
45	467467350	PACKING (R), HANDLE	1	
46	0105050616	BOLT 6X15	6	REPLACES P/N 001220615
47	030206150	WASHER, LOCK M6	6	
48	952404470	WASHER, FLAT M6.....	6	REPLACES P/N 031106100
49	464457930	RUBBER PIECE	1	

CONTROL ASSY. (CONT'D.)

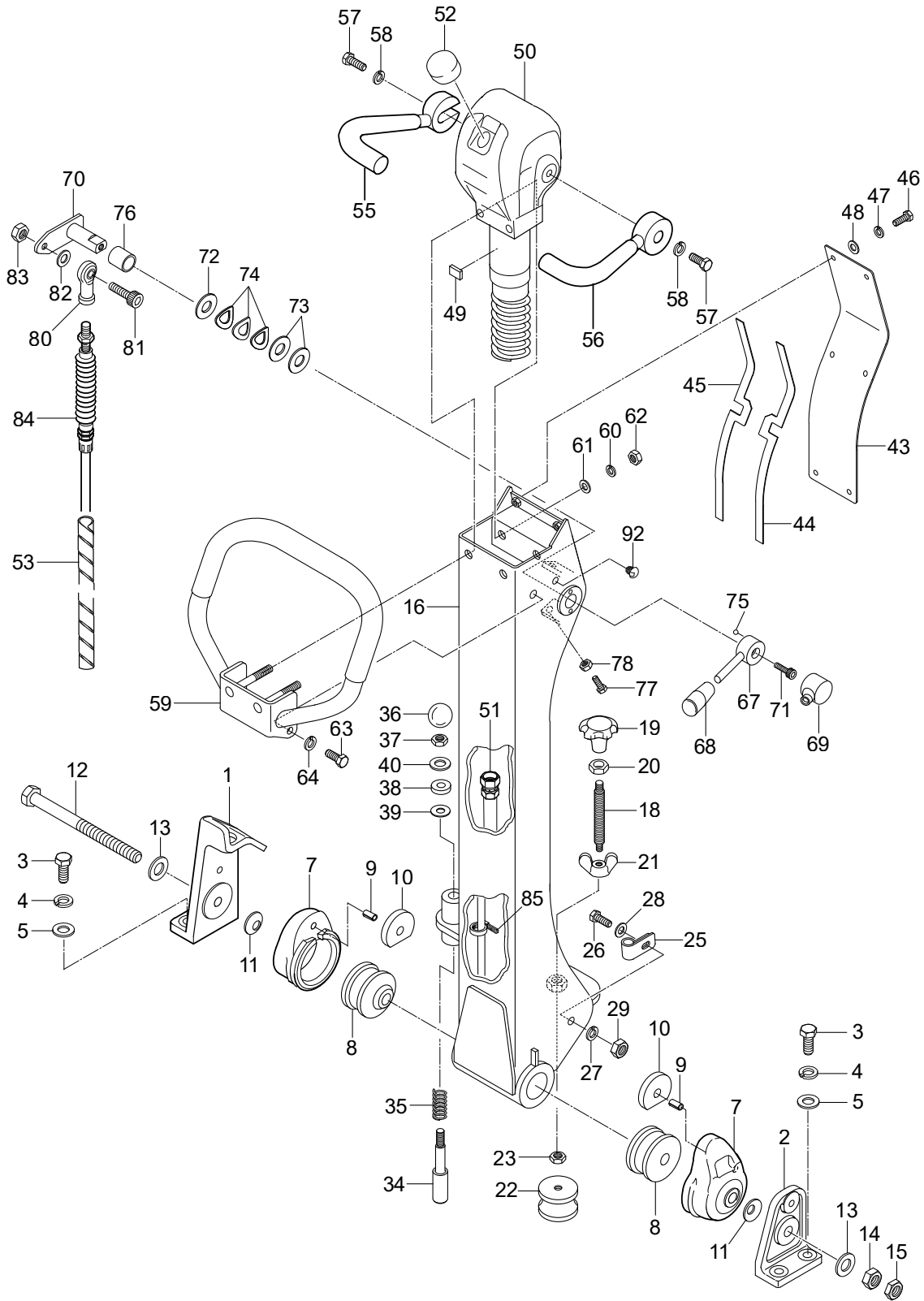

CONTROL ASSY. (CONT'D.)

<u>NO.</u>	<u>PART NO.</u>	<u>PART NAME</u>	<u>QTY.</u>	<u>REMARKS</u>
50	469219180	HAND PUMP (EXP.)	1	
51	954003110	OIL HOSE	1	
52	458451630	BREATHER CAP	1	
53	959021813	SPIRAL TUBE	1	
54	959409120	PROTECT TUBE	1	
55	464216820	TRAVEL LEVER (R)	1	
56	464216830	TRAVEL LEVER (L)	1	
57	012010030	BOLT 10X30	2	REPLACES P/N 001221030
58	030210250	WASHER, LOCK M10	2	
59	467218900	GRIP	1	
60	030210250	WASHER, LOCK M10	2	
61	031110160	WASHER, FLAT M10	2	
62	020310080	NUT M10	2	
63	0105091025	BOLT 10X25	2	REPLACES P/N 001221025
64	030210250	WASHER, LOCK M10	2	
67	467467380	THROTTLE LEVER	1	
68	959403840	BAR GRIP, I.D. 12MM	1	
69	464457420	COVER, THROTTLE LEVER	1	
70	464457350	ARM, THROTTLE	1	
71	014208020	SOCKET HEAD BOLT 8X20.....	1	REPLACES P/N 001520820
72	0401450160	WASHER, FLAT M16.....	1	REPLACES P/N 031116260
73	458450660	WASHER	2	
74	033910080	CONICAL WASHER, LOCK	3	
75	464457440	STEEL BALL	1	
76	464010010	DRY BUSHING	1	
77	011606025	BOLT 6X25	2	REPLACES P/N 001220625
78	020106050	NUT M6.....	2	REPLACES P/N 020306050
80	464010020	ROD END M5	1	
81	001520520	SOCKET HEAD BOLT 5X20	1	
82	58151	WASHER, FLAT M5.....	1	REPLACES P/N 031105080
83	020305040	NUT M5	1	
84	956100070	THROTTLE WIRE	1	
85	506010070	CLAMP	1	
92	953409110	BRUSH CLIP	2	

HAND PUMP (EXP.) ASSY.

©:O-RING,DUST SEAL SET
(INCLUDES ITEMS W / Ref.No.16-19,26-28,52,53)

C

For disassembly (Option)

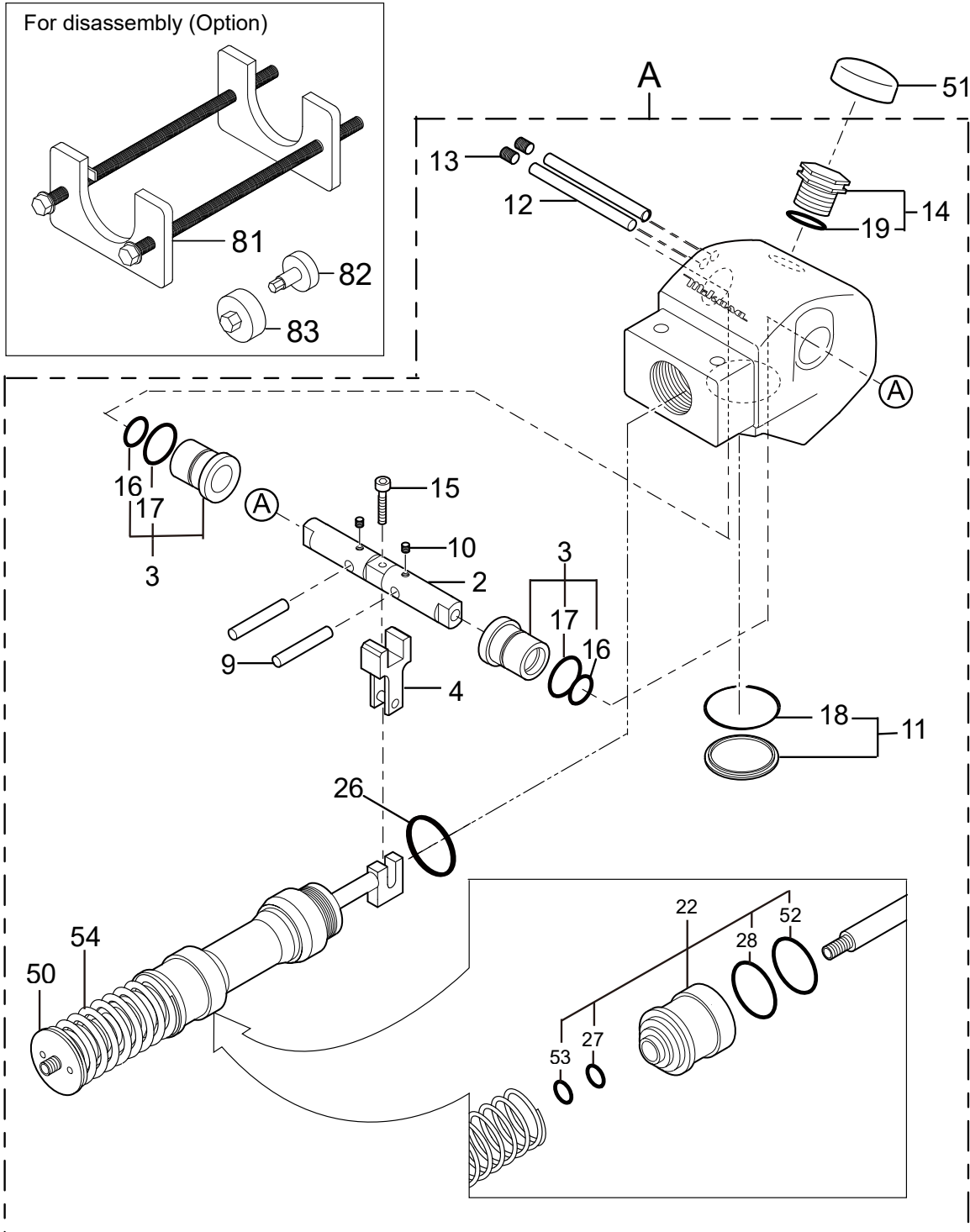

HAND PUMP (EXP.) ASSY.

<u>NO.</u>	<u>PART NO.</u>	<u>PART NAME</u>	<u>QTY.</u>	<u>REMARKS</u>
A	469219180	HAND PUMP (EXP.)	1.....	INCLUDES ITEMS W/&
C	464910080	O-RING & DUST, SEAL, SET	1.....	INCLUDES ITEMS W/%
2&	464010040	CONTROL SHAFT (PUMP)	1	
3&	467010020	BUSH	2.....	INCLUDES ITEMS W/\$
4&	464010060	CAM (PUMP)	1	
9&	464010070	STOPPER (PUMP)	2	
10&	099205005	SOCKET HEAD SCREW 5X5	2	
11&	464010080	PLUG	1.....	INCLUDES ITEM W/@
12&	464010090	PIN, STOPPER (PUMP)	2	
13&	464010100	PLUG	2	
14&	458010080	BREATHER (PUMP).....	1.....	INCLUDES ITEM W/#
15&	014206020	SOCKET HEAD BOLT 6X20.....	1.....	REPLACES P/N 001520620
16&\$	050200200	O-RING, P-20	2	
17&\$	050210220	O-RING, P-22	2.....	REPLACES P/N 050200220
18&%@	050300380	O-RING, S-38	1	
19&%#	050200180	O-RING, P-18	1	
22&	464010111	ACCUMULATOR CASE.....	1.....	INCLUDES ITEMS W/+
26&%	050300400	O-RING, S-40	1	
27&%+	050200150	O-RING, P-15	1	
28&%+	050100400	O-RING, G-40	1	
50&	464010120	SPRING PLUG	1	
51	458451630	BREATHER CAP	1	
52&%+	069904010	DUST SEAL SER-40	1	
53&%+	069901010	DUST SEAL SER-15	1	
54&	468910030	ACCUMULATOR SPRING SET	1	
81	984010060	SPRING COMPRESSION TOOL/EXP	1	
82	984010040	DISASSEMBLING TOOL A	1	
83	984010050	DISASSEMBLING TOOL B	1	

ENGINE SERVICE PARTS

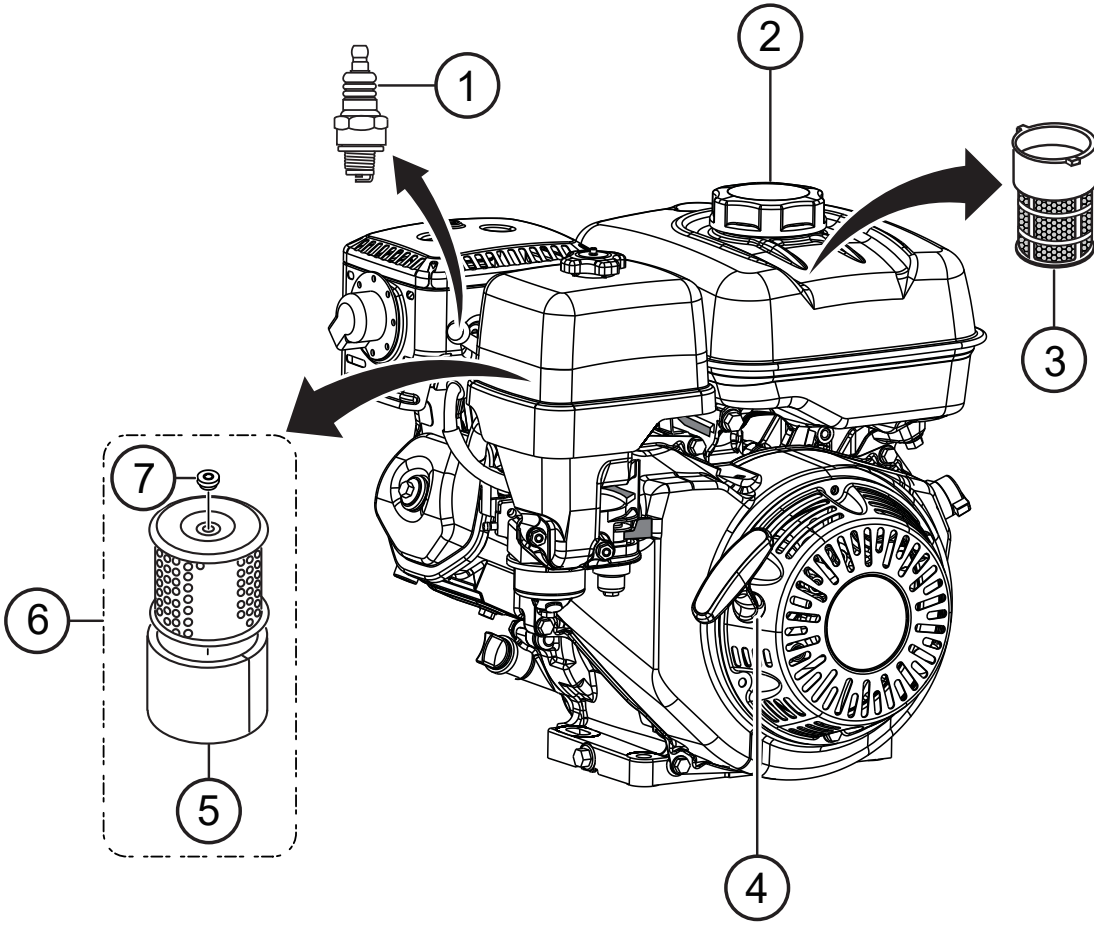

ENGINE SERVICE PARTS

<u>NO.</u>	<u>PART NO.</u>	<u>PART NAME</u>	<u>QTY.</u>	<u>REMARKS</u>
1	0650140480	SPARK PLUG (BPR6ES)	1	
2	17620Z4H900	CAP, FUEL TANK	1	
3	17672Z4H000	FUEL FILTER, FUEL TANK	1	
4	28462ZE3W01	ROPE, RECOIL STATER	1	
5#	17218Z1C780	FILTER, OUTER	1	
6	17210Z1C781	ELEMENT, AIR CLEANER.....	1.....	INCLUDES ITEMS W/#
7#	17232891000	GROMMET, AIR CLEANER	1	

PARTS MANUAL

HERE'S HOW TO GET HELP

PLEASE HAVE THE MODEL AND SERIAL
NUMBER ON-HAND WHEN CALLING

UNITED STATES

Multiquip Inc.

(310) 537- 3700
6141 Katella Avenue Suite 200
Cypress, CA 90630
E-MAIL: mq@multiquip.com
WEBSITE: www.multiquip.com

CANADA

Multiquip

(450) 625-2244
4110 Industriel Boul.
Laval, Quebec, Canada H7L 6V3
E-MAIL: infocanada@multiquip.com

UNITED KINGDOM

Multiquip (UK) Limited Head Office

0161 339 2223
Unit 2, Northpoint Industrial Estate, Globe Lane,
Dukinfield, Cheshire SK16 4UJ
E-MAIL: sales@multiquip.co.uk

© COPYRIGHT 2023, MULTIQUIP INC.

Multiquip Inc, the MQ logo are registered trademarks of Multiquip Inc. and may not be used, reproduced, or altered without written permission. All other trademarks are the property of their respective owners and used with permission.

This manual MUST accompany the equipment at all times. This manual is considered a permanent part of the equipment and should remain with the unit if resold.

The information and specifications included in this publication were in effect at the time of approval for printing. Illustrations, descriptions, references and technical data contained in this manual are for guidance only and may not be considered as binding. Multiquip Inc. reserves the right to discontinue or change specifications, design or the information published in this publication at any time without notice and without incurring any obligations.

