

PARTS MANUAL



***ESSICK* SERIES MODELS**

PRO12C/PRO12E51C

PRO12E53C/PRO12E53-460VC

HYDRAULIC PLASTER/MORTAR MIXERS

**(HONDA GX390RT2-QNB2 GASOLINE ENGINE/
TECO WESTINGHOUSE 5HP ELECTRIC MOTOR)**

Revision #0 (08/25/20)

To find the latest revision of this publication or associated operation manual, visit our website at: www.multiquip.com



THIS MANUAL MUST ACCOMPANY THE EQUIPMENT AT ALL TIMES.

TABLE OF CONTENTS

PRO12C Hydraulic Mixer

Table of Contents.....	2
Explanation of Code in Remarks Column.....	4
Suggested Spare Parts	5

Component Drawings

Nameplate and Decals	6-7
Paddle Blades Assembly	8-9
Drum Assembly	10-11
Hydraulic Assembly	12-13
Frame Assembly	14-15
Cover Assembly.....	16-17
Engine Assembly	18-19
Electric Motor Assembly	20-21
Fuel Tank Assembly.....	22-23

NOTICE

Specifications and part numbers are subject to change without notice.

EXPLANATION OF CODE IN REMARKS COLUMN

The following section explains the different symbols and remarks used in the Parts section of this manual. Use the help numbers found on the back page of the manual if there are any questions.

NOTICE

The contents and part numbers listed in the parts section are subject to change **without notice**. Multiquip does not guarantee the availability of the parts listed.

SAMPLE PARTS LIST

NO.	PART NO.	PART NAME	QTY.	REMARKS
1	12345	BOLT	1	INCLUDES ITEMS W/%
2%		WASHER, 1/4 IN.		NOT SOLD SEPARATELY
2%	12347	WASHER, 3/8 IN. ...	1	MQ-45T ONLY
3	12348	HOSE	A/R	MAKE LOCALLY
4	12349	BEARING	1	S/N 2345B AND ABOVE

NO. Column

Unique Symbols — All items with same unique symbol (@, #, +, %, or >) in the number column belong to the same assembly or kit, which is indicated by a note in the “Remarks” column.

Duplicate Item Numbers — Duplicate numbers indicate multiple part numbers, which are in effect for the same general item, such as different size saw blade guards in use or a part that has been updated on newer versions of the same machine.

NOTICE

When ordering a part that has more than one item number listed, check the remarks column for help in determining the proper part to order.

PART NO. Column

Numbers Used — Part numbers can be indicated by a number, a blank entry, or TBD.

TBD (To Be Determined) is generally used to show a part that has not been assigned a formal part number at the time of publication.

A blank entry generally indicates that the item is not sold separately or is not sold by Multiquip. Other entries will be clarified in the “Remarks” Column.

QTY. Column

Numbers Used — Item quantity can be indicated by a number, a blank entry, or A/R.

A/R (As Required) is generally used for hoses or other parts that are sold in bulk and cut to length.

A blank entry generally indicates that the item is not sold separately. Other entries will be clarified in the “Remarks” Column.

REMARKS Column

Some of the most common notes found in the “Remarks” Column are listed below. Other additional notes needed to describe the item can also be shown.

Assembly/Kit — All items on the parts list with the same unique symbol will be included when this item is purchased.

Indicated by:

“INCLUDES ITEMS W/(unique symbol)”

Serial Number Break — Used to list an effective serial number range where a particular part is used.

Indicated by:

“S/N XXXXX AND BELOW”

“S/N XXXX AND ABOVE”

“S/N XXXX TO S/N XXX”

Specific Model Number Use — Indicates that the part is used only with the specific model number or model number variant listed. It can also be used to show a part is NOT used on a specific model or model number variant.

Indicated by:

“XXXXX ONLY”

“NOT USED ON XXXX”

“Make/Obtain Locally” — Indicates that the part can be purchased at any hardware shop or made out of available items. Examples include battery cables, shims, and certain washers and nuts.

“Not Sold Separately” — Indicates that an item cannot be purchased as a separate item and is either part of an assembly/kit that can be purchased, or is not available for sale through Multiquip.

SUGGESTED SPARE PARTS

PRO12C HYDRAULIC MIXER WITH HONDA GX390RT2-QNB2 ENGINE

1 to 3 units

Qty.	P/N	Description
1	521426	KIT, RUBBER BLADES, SCRAPERS & HWD.
6	802366	SEAL, PADDLE SHAFT
4	802367	SEPARATOR, PADDLE SHAFT SEALS
2	802368	COVER, SEAL
1	10958	SWITCH, IGN., W/KEYS
2	11078	KEYSET, IGNITION
1	29173-001	SWITCH, PUSH-PULL, W/O KNOB
1	29174-001	KNOB-MUSHROOM
1	491010	LATCH KIT, ENGINE HOUSING
1	3353	CAP, FILLER/BREATHER
3	17210ZE3505	ELEMENT, A/C DUAL
3	9807956846	SPARK PLUG BPR6ES
3	EM20763	FILTER, FUEL, IN-LINE
2	508667	ELEMENT, OIL, HYDRAULIC

NOTICE

Part numbers on this Suggested Spare Parts list may supersede/replace the part numbers shown in the following parts lists.

NAMEPLATE AND DECALS

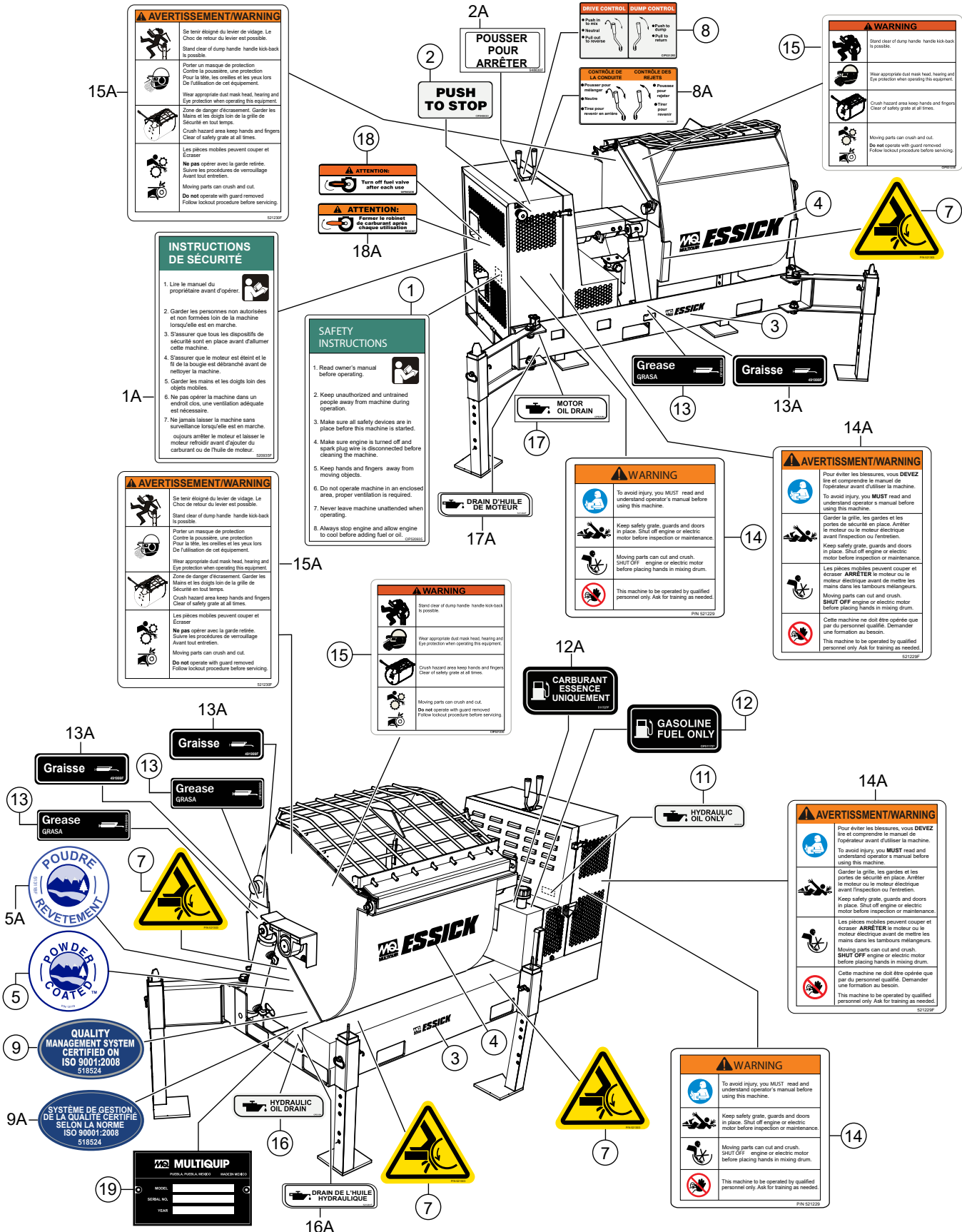

NAMEPLATE AND DECALS

<u>NO.</u>	<u>PART NO.</u>	<u>PART NAME</u>	<u>QTY.</u>	<u>REMARKS</u>
1	520935	DECAL, SAFETY INSTRUCTIONS	1	
1A	520935F	DECAL, SAFETY INSTRUCTIONS (FR)	1	
2	EM948630	DECAL, PUSH TO STOP	1	
2A	948630F	DECAL, PUSH TO STOP (FR)	1	
3	EM510891	DECAL, MQ ESSICK MEDIUM	2	
4	EM510883	DECAL, MQ ESSICK LARGE	2	
5	13118	DECAL, POWDER COATED	1	
5A	513118F	DECAL, POWDER COATED (FR)	1	
7	521303	DECAL, PINCH POINT	5	
8	521293	DECAL, DRIVE/DUMP CONTROL 1	1	
8A	521293F	DECAL, DRIVE/DUMP CONTROL 1 (FR)	1	
9	518524	DECAL, ISO 9001:2000 EXPORT	1	
9A	518524F	DECAL, ISO 90001:2008 (FR)	1	
11	EM985	DECAL, HYDRAULIC OIL ONLY	1	
12	511727	DECAL, GASOLINE FUEL ONLY	1	
12A	511727F	DECAL, GASOLINE FUEL ONLY (FR)	1	
13	491999	DECAL, GREASE	8	
13A	491999F	DECAL, GREASE (FR)	8	
14	521229	DECAL, WARNING 4 POINTS	2	
14A	521229F	DECAL, WARNING 4 POINTS (FR)	2	
15	521230	DECAL, PREVENT ACCIDENTS	2	
15A	521230F	DECAL, PREVENT ACCIDENTS (FR)	2	
16	521291	DECAL, HYDRAULIC OIL DRAIN	1	
16A	521291F	DECAL, HYDRAULIC OIL DRAIN (FR)	1	
17	521292	DECAL, MOTOR OIL DRAIN	1	
17A	521292F	DECAL, MOTOR OIL DRAIN (FR)	1	
18	803236	DECAL, TURN OFF FUEL VALVE	2	
18A	803236F	DECAL, TURN OFF FUEL VALVE (FR)	2	
19		PLATE, SERIAL NUMBER.....1.....CONTACT MQ PARTS DEPT.		

PADDLE BLADES ASSY.

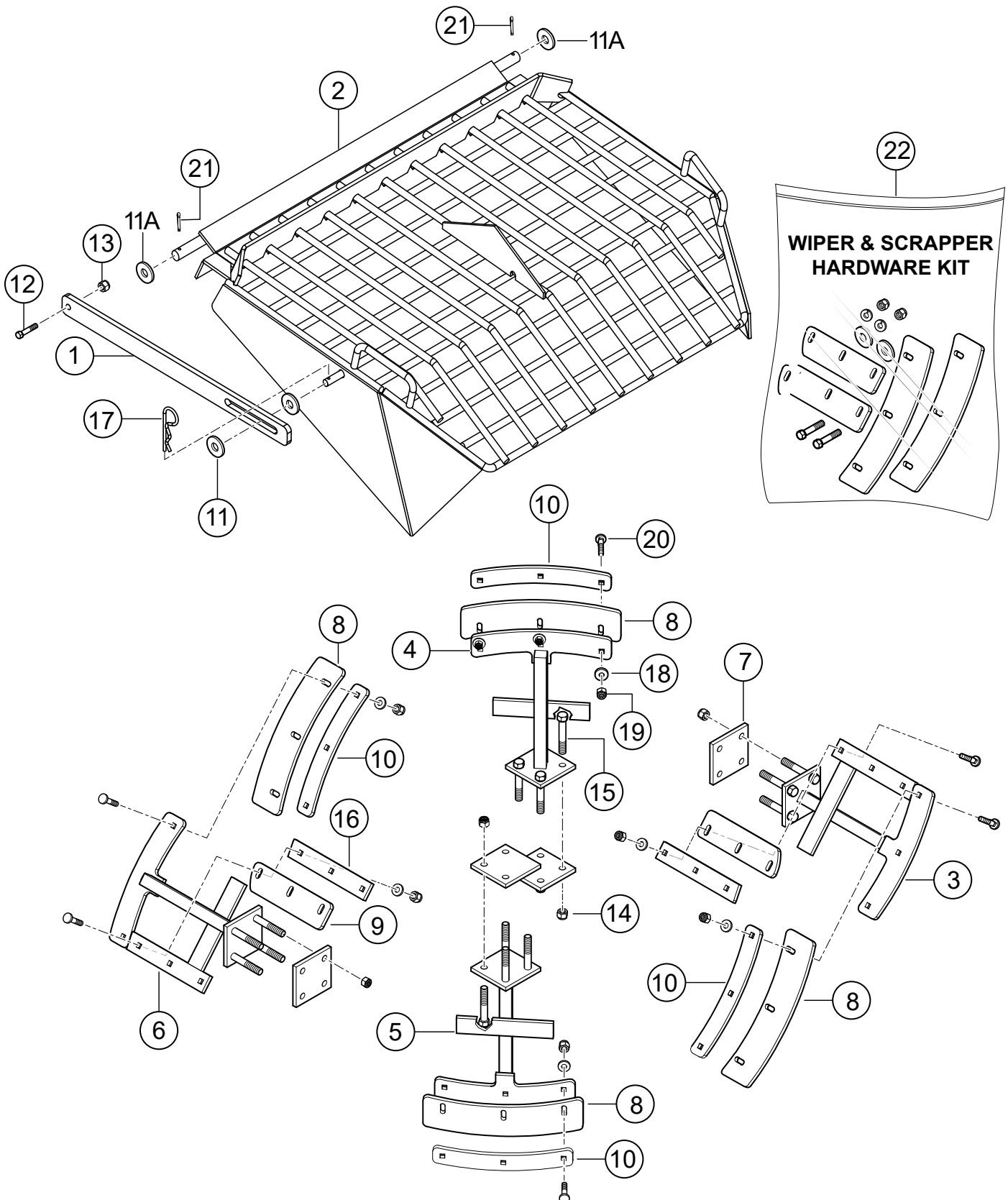

PADDLE BLADES ASSY.

<u>NO.</u>	<u>PART NO.</u>	<u>PART NAME</u>	<u>QTY.</u>	<u>REMARKS</u>
1	522099	BAR, GRATE SPECIAL CSST	1	
2	522082	GRATE, SAFETY SPECIAL CSST	1	
3	802452	PADDLE ARM, END	1	
4	802453	PADDLE ARM, CENTER	1	
5	802454	PADDLE ARM, CENTER ENGINE END	1	
6	802455	PADDLE ARM, ENGINE END	1	
7	802443	RETAINER BASE, PADDLE ARM	4	
8\$	802447	RUBBER BLADE, SIDE	4	
9\$	802448	RUBBER BLADE END	2	
10\$	802451	STEEL BLADE, SIDE	4	
11	0401450160	WASHER FLAT 5/8"	4	
11A	507444	SPACER	2	
12	492378	BOLT, HHCS, GRD5	1	
13	EM969013	NUT, 3/8" .NYLOK GRD88	1	
14	492584	NUT LOCK 1/2" DIA NC GRD5	16	
15	3215	SCREW HHC 1/2-13 X 3-1/2" GRD5	16	
16\$	802449	STEEL BLADE, END	2	
17	EM745	HAIR PIN C 5/8-3/4"	1	
18\$	3019092	WASHER, FLAT 3/8"	18	
19\$	EM969013	NUT, 3/8" NYLOC G8	18	
20\$	505883	SCREW, 3/8-NC X 2" GRD5	18	
21	EM924015	PIN COTTER	2	
22	521426	KIT, RUBBER BLADES, SCRAPPERS, HDW....1.....		INCLUDES ITEMS W/\$

DRUM ASSY.

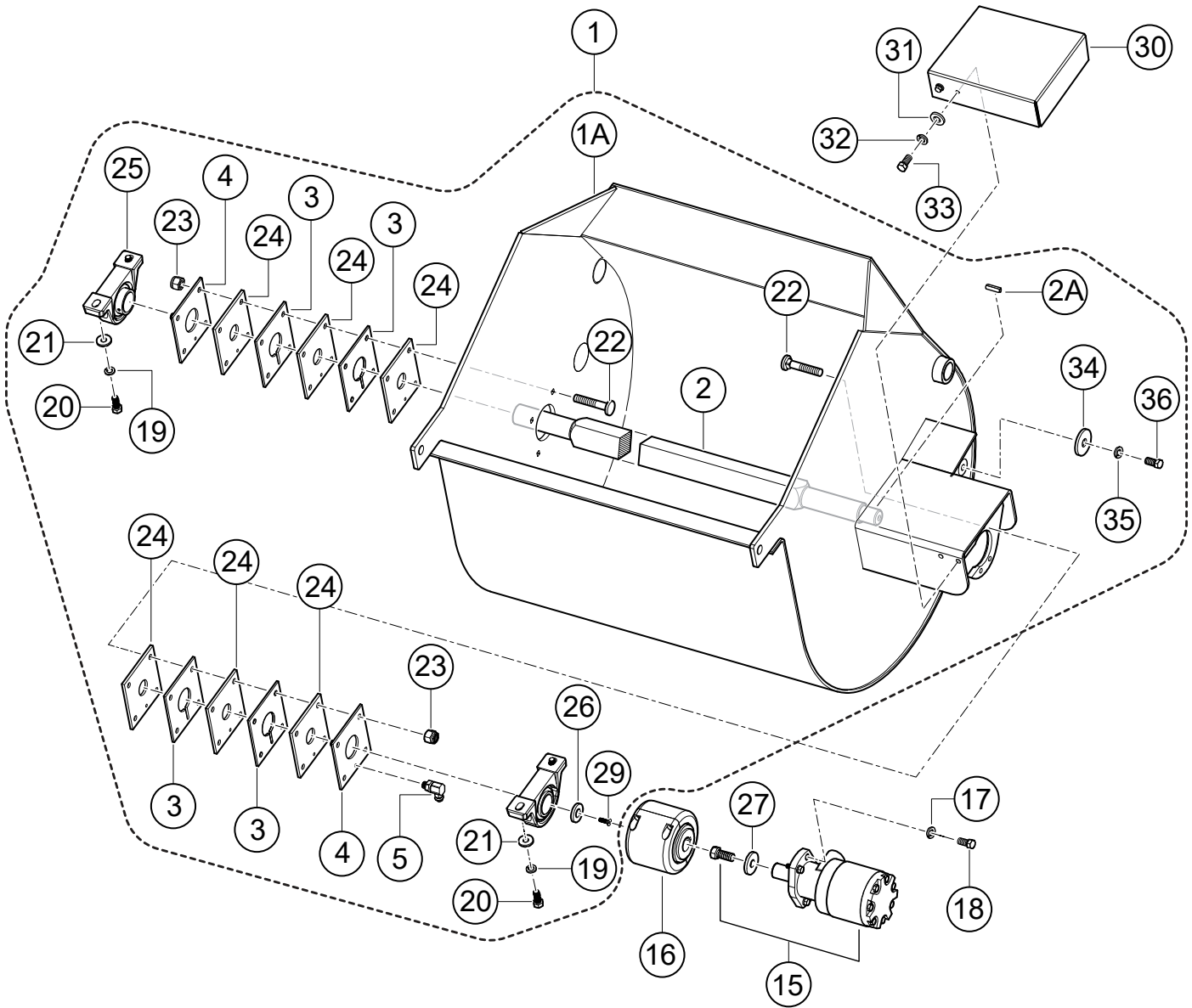

DRUM ASSY.

<u>NO.</u>	<u>PART NO.</u>	<u>PART NAME</u>	<u>QTY.</u>	<u>REMARKS</u>
1	521958	DRUM AND SHAFT ASSY.....	1.....	INCLUDES ITEMS W/@
1A@	802320	DRUM, BARE	1	
2@	802361	PADDLE SHAFT	1	
2A@	502727	WEDGE	1	
3@	802367	SEPARATOR	4	
4@	802368	COVER, SEAL	2	
5@	491704	FITTING ZERK	2	
15	34570	MOTOR, HYDRAULIC W/BOLT	1	
16	802414	COUPLER	1	
17	0166 A	WASHER, LOCK 3/8"	4	
18	EM963610	BOLT, 3/8-NC X 1-1/4" GRD5	4	
19@	6109180	WASHER, LOCK 1/2"	4	
20@	EM963102	CAPSCREW, HHC 1/2-NC X 1-1/4" GRD5	4	
21@	492599	WASHER, FLAT 1/2"	4	
22@	505883	BOLT, 3/8-NC X 2" GRD5	8	
23@	EM969013	NUT, NYLOC	8	
24@	802366	SEAL, PADDLE SHAFT	6	
25@	802415	BEARING	2	
26@	802667	WASHER, 5/16"	1	
27	802912	WASHER, 5/8"	1	
29@	506176	BOLT, 5/16-18 X 1" FHAS	1	
30	802945	COVER	1	
31	509161	WASHER, FLAT 5/16"	4	
32	EM923343	WASHER, LOCK 5/16"	4	
33	492362	BOLT, 5/16-NC X 5/8"	4	
34@	530183	WASHER, FLAT 1/2"	2	
35@	6109180	WASHER, LOCK 1/2"	2	
36@	EM963692	CAPSCREW, HHCS 1/2-13 X 1-1/2"	2	

HYDRAULIC ASSY.

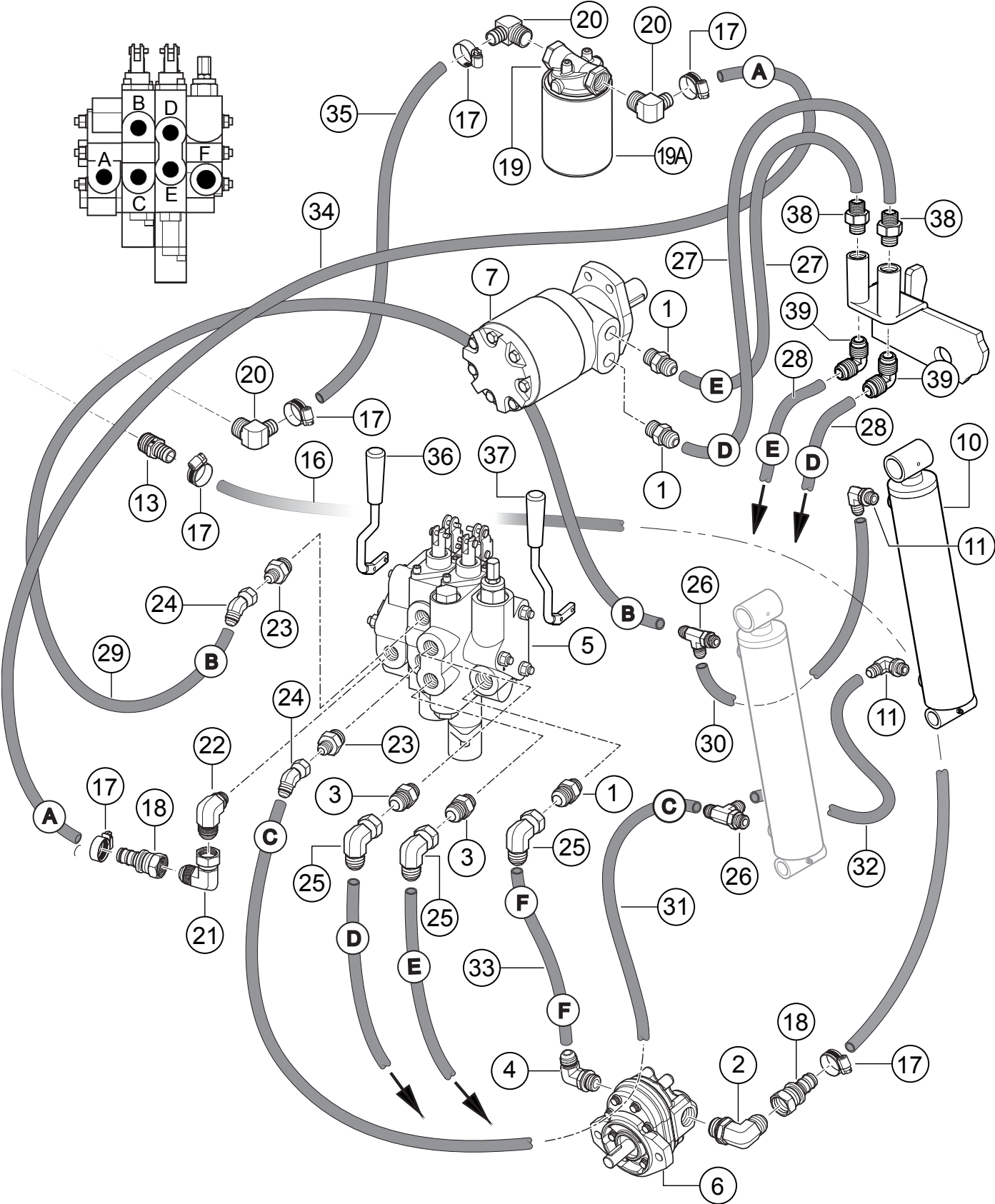

HYDRAULIC ASSY.

<u>NO.</u>	<u>PART NO.</u>	<u>PART NAME</u>	<u>QTY.</u>	<u>REMARKS</u>
1	3365	FITTING, STR.	3	
2	EM25459	ELBOW, 3/4"-90°	1	
3	16587	FITTING, STR	2	
4	3322	FITTING, 90°	1	
5	34585	VALVE, FOUR WAY	1	
6	13374	PUMP, EATON W/BOLT	1	
7	34570	MOTOR, HYDRAULIC	1	
10	802280	CYLINDER, HYD.	2	
11	506196	ELBOW	2	
13	13220	FITTING, STR 12BARB-3/4MP	1	
16	13380	HOSE, 3/4ID X 18-1/2" SAE100R4	1	
17	506207	CLAMP HOSE HS-16	6	
18	511847	FITTING	2	
19	8051	FILTER ASSY., HYD OIL	1.....	INCLUDES ITEM W/\$
19A\$	508667	ELEMENT, HYD. OIL	1	
20	3367	FITTING, 90°	3	
21	509353	ADAPTER, ELBOW	1	
22	515219	FITTING, VALVE	1	
23	512190	ADAPTER, STRAIGHT	2	
24	512234	ADAPTER, ELBOW	2	
25	512201	ADAPTER, ELBOW	3	
26	802938	ADAPTER	2	
27	803352	HOSE, 850MM	2	
28	803353	HOSE, 1000MM	2	
29	803001	HOSE, 1440MM	1	
30	803002	HOSE, 1585MM	1	
31	803003	HOSE, 1270MM	1	
32	803004	HOSE, 980MM	1	
33	803005	HOSE, 656MM	1	
34	803006	HOSE, 1100MM	1	
35	803007	HOSE, 130MM	1	
36	803048	HANDLE, VALVE, LEFT	1	
37	803049	HANDLE, VALVE, RIGHT	1	
38	516675	ADAPTER, STR.	2	
39	509784	ADAPTER, ELBOW 90°	2	

FRAME ASSY.

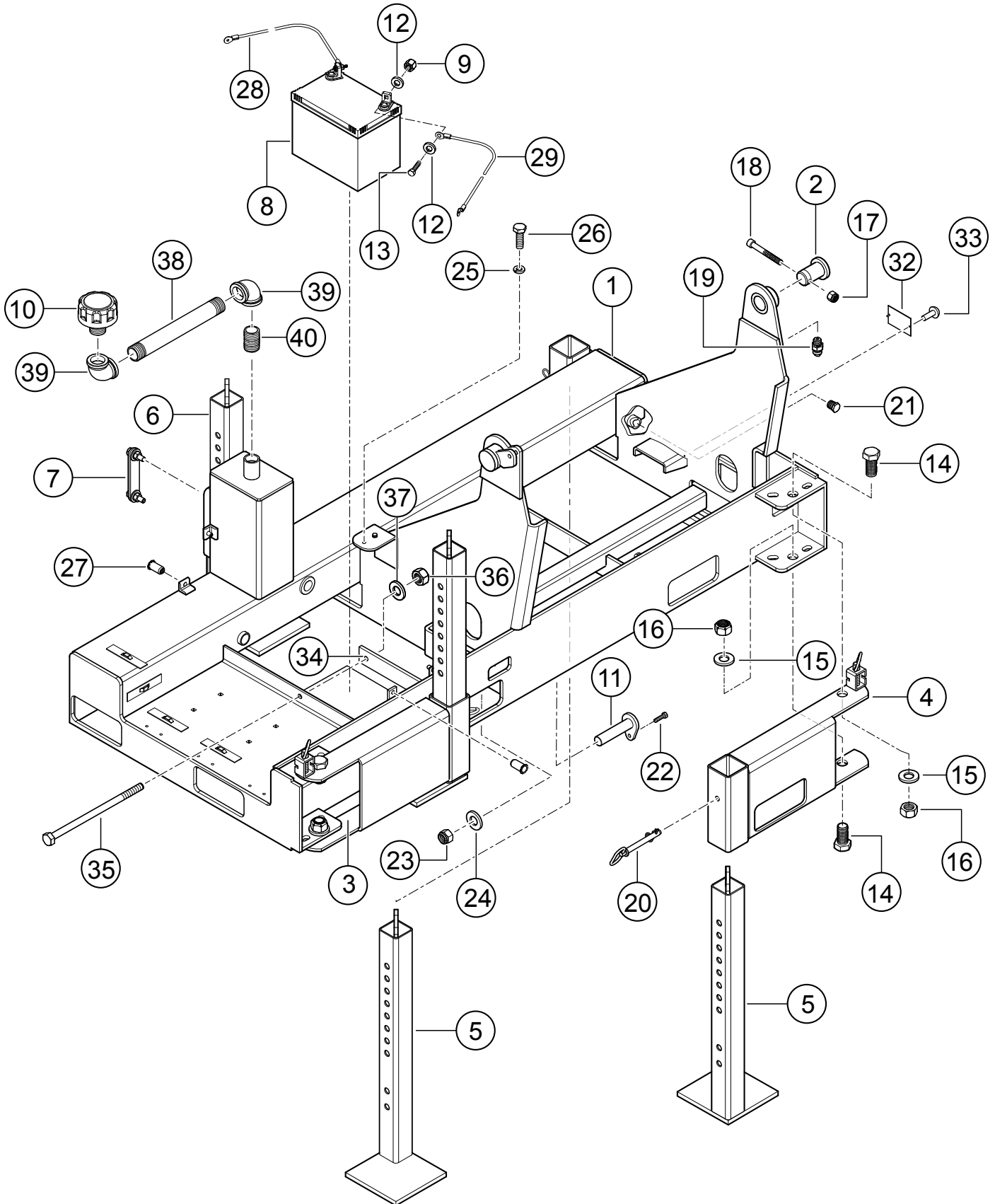

FRAME ASSY.

<u>NO.</u>	<u>PART NO.</u>	<u>PART NAME</u>	<u>QTY.</u>	<u>REMARKS</u>
1	802300	FRAME	1	
2	802362	CAP	2	
3	802331	LEG, LEFT	1	
4	802333	LEG, RIGHT	1	
5	802335	STAND, ADJUSTABLE	2	
6	802336	STAND, ADJUSTABLE	2	
7	18052	SIGHT GAUGE	1	
8	4671	BATTERY 12V GROUP U1 WET CELL	1	
9	503119	NUT, LOCK	2	
10	3353	CAP, FILLER/BREATHER	1	
11	802363	RETAINER, CYLINDER	2	
12	492595	WASHER, FLAT 3/16"	4	
13	503118	BOLT, 3/16" X 1"	2	
14	502125	BOLT, 1"-NF X 2" GRD5	4	
15	3047	SPACER	4	
16	TK86D16	NUT, 1"-NF	4	
17	EM969013	NUT, NYLOC	2	
18	520894	BOLT, 3/8-NC X 3" GRD8.8	2	
19	EM916019	FITTING, GREASE	2	
20	EM744	PIN, 1/2" X 4"	4	
21	506094	PLUG, 1/2NPT GALVANIZED	1	
22	492303	BOLT, 5/16-NC X 1-1/4"	2	
23	2105164	NUT, NYLON 5/16-18	2	
24	EM923023	WASHER, FLAT 5/16"	2	
25	2101402	WASHER, LOCK 1/4"	2	
26	492356	BOLT 1/4" X 3/4"	2	
27	DULT100602	NUT, M6	4	
28	512557	CABLE (-) BATTERY	1	
29	511250	CABLE (+) BATTERY	1	
32	520800	PLATE, SERIAL, EMISSION CONTROL	1	
33	491757	RIVET, ID PLATE	2	
34	802314	RETAINER BAR	1	
35	13217	SCREW, HHC 3/8-16 X 6" GRD5	2	
36	492551	NUT, 3/8-16	2	
37	0166 A	WASHER, LOCK 3/8"	2	
38	803069	PIPE, 1"NPT X 10" GALV.	1	
39	491189	ELBOW, 90° 1"NPT GALV.	2	
40	491160	PLUG, PIPE 1"NPT	1	

COVER ASSY.

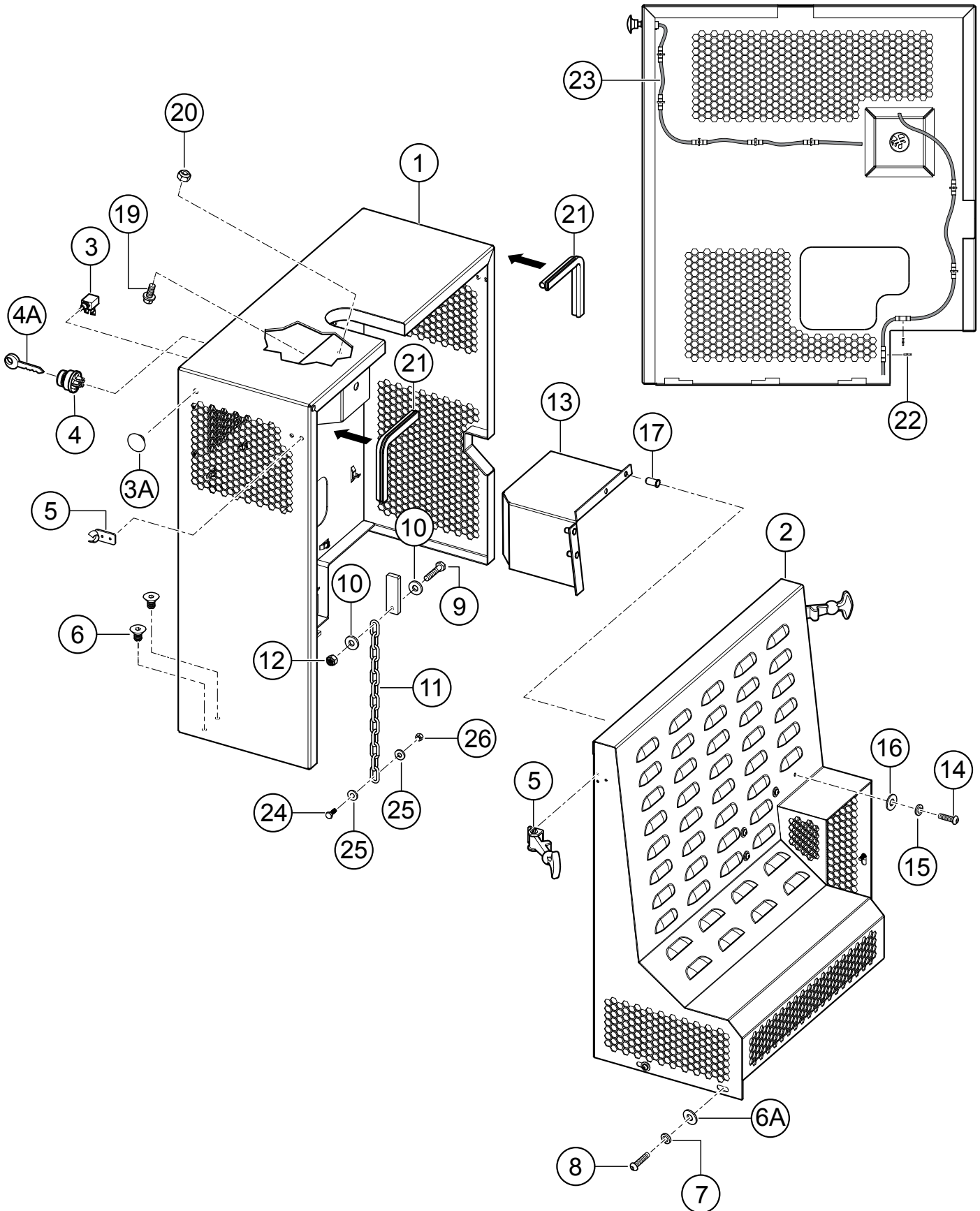

COVER ASSY.

<u>NO.</u>	<u>PART NO.</u>	<u>PART NAME</u>	<u>QTY.</u>	<u>REMARKS</u>
1	802340	COVER, MOVEABLE	1	
2	802346	COVER, FIXED	1	
3	29173-001	SWITCH, PUSH PULL W/O KNOB	1	
3A	29174-001	KNOB-MUSHROOM	1	
4	10958	SWITCH, IGN, W/KEYS.....	1	INCLUDES ITEM W/\$
4A\$	11078	KEYSET, IGNITION	1	
5	491010	LATCH KIT ENGINE HOUSING	2	
6	510476	BOLT, 5/16-NC X 1/2"	4	
6A	EM923057	WASHER , FLAT1/4"	4	
7	2101402	WASHER LOCK 1/4"	4	
8	DULT100443	BOLT, M6 X 20 P-1 GRD2	4	
9	EM492358	BOLT 1/4-NC X 1-1/4"	1	
10	EM923057	WASHER, FLAT 1/4"	2	
11	803057	CHAIN	1	
12	492581	NUT, 1/4-20 NYLOC	1	
13	802962	HEAT SHIELD, MUFFLER	1	
14	DULT100443	BOLT, M6 X 20 P-1 GRD2	3	
15	2101402	WASHER, LOCK 1/4"	3	
16	EM923057	WASHER, FLAT 1/4".	3	
17	DULT100602	NUT, M6	3	
19	512367	BOLT, 3/16-NC X 1/2" GRD2	2	
20	503119	NUT, LOCK 3/16" NC	2	
21	800033	WEATHER STRIPING, 1.5FT.....	2	1PC=1FT
22	EM491028	WRAP, CABLE TIE, BLACK	9	
23	510573	HARNESS CABLE, ENGINE	1	
24	492356	BOLT, 1/4" X 3/4"	1	
25	EM923057	WASHER, FLAT 3/4"	2	
26	492581	NUT, 1/4-20 NYLOC	1	

ENGINE ASSY.

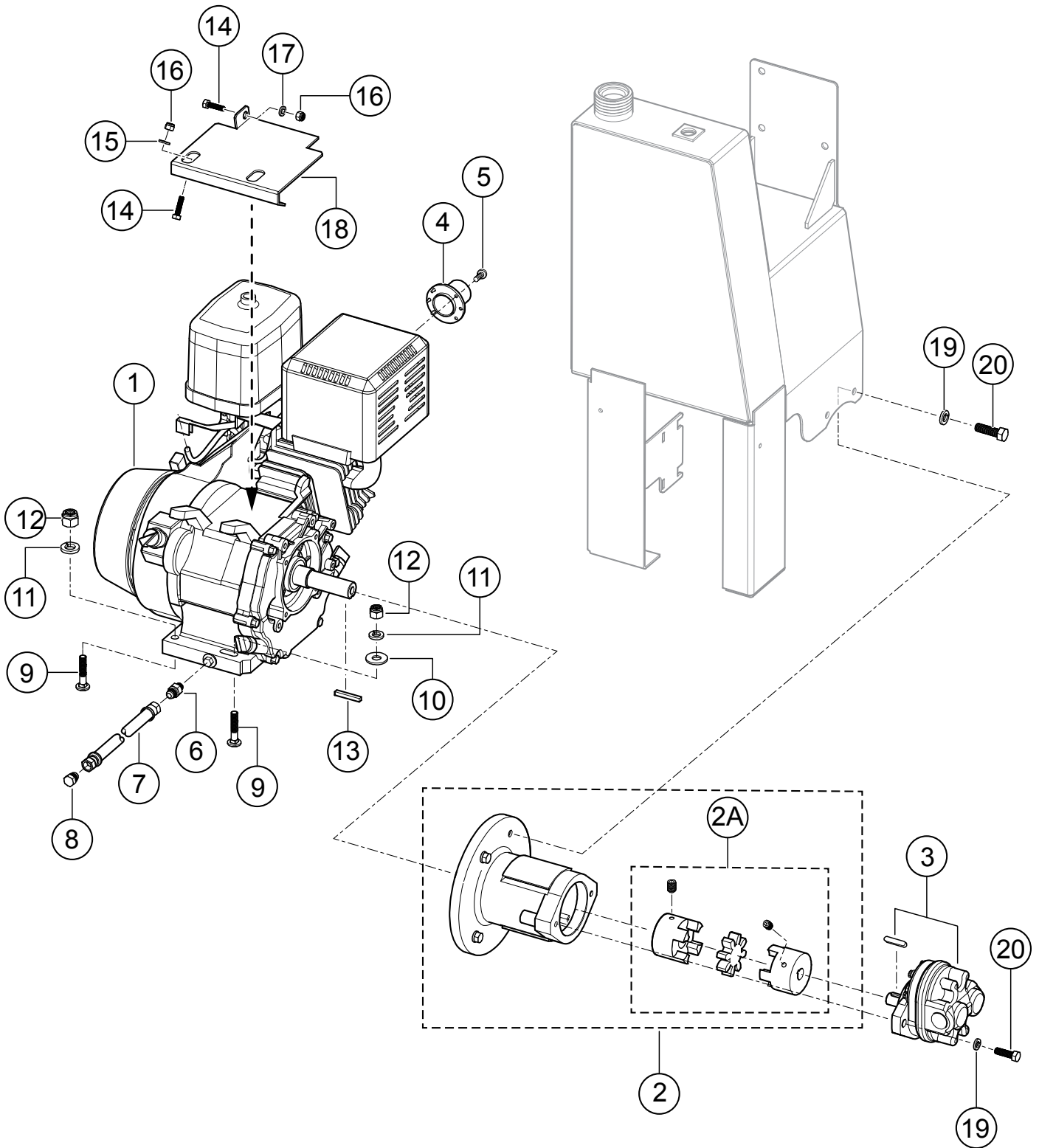

ENGINE ASSY.

<u>NO.</u>	<u>PART NO.</u>	<u>PART NAME</u>	<u>QTY.</u>	<u>REMARKS</u>
1	520766	ENGINE, HONDA, ELEC START. 13HP EPA.....1.....	1	GX390RT2-QNB2
2	516282	COUPLING ASSY.	1	
2A	516282C	JAW COUPLER	1	
3	13374	PUMP, EATON W/KEY	1	
4	803028	MUFFLER, EXHAUST	1	
5	491757	RIVET	6	
6	800780	ADAPTER, 6M12F870MX	1	
7	800776	HOSE, DRAIN	1	
8	513619	FITTING	1	
9	505883	BOLT, 3/8-NC X 2" GRD5	4	
10	3019092	WASHER, FLAT 3/8"	2	
11	0166 A	WASHER, LOCK, 3/8" MED	4	
12	EM969013	NUT, NYLOC, 3/8-NC	4	
13	90745ZE2600	KEY, 6.3 X 6.3 X 43MM	1	
14	492303	BOLT, 5/16-NC X 1-1/4" GRD5	3	
15	EM923057	WASHER, FLAT 1/4"	2	
16	2105164	NUT, NYLOC, 5/16-NC	3	
17	508344	WASHER, FLAT, 5/16"	1	
19	0166 A	WASHER, LOCK, 3/8" MED	6	
20	EM963610	CAPSCREW, 3/8-NC X 1-1/4" GRD8	6	

ELECTRIC MOTOR ASSY.

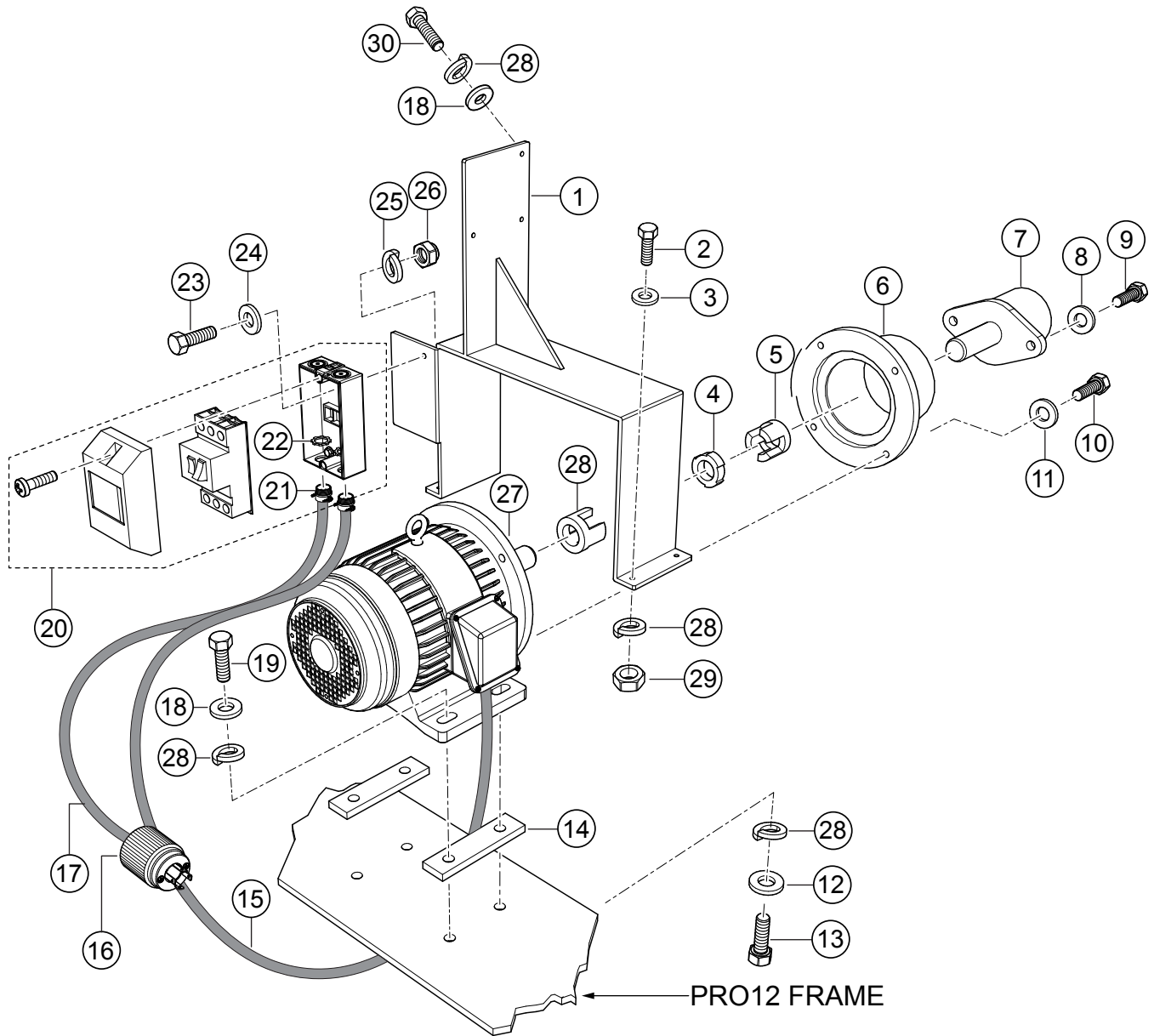

ELECTRIC MOTOR ASSY.

<u>NO.</u>	<u>PART NO.</u>	<u>PART NAME</u>	<u>QTY.</u>	<u>REMARKS</u>
1	EM98283	BRACKET, SUPPORT VALVE	1	
2		BOLT, 3/8-16 X 1-1/4"	4	OBTAIN LOCALLY
3		WASHER, FLAT 3/8"	4	OBTAIN LOCALLY
4	3418	INSERT ,RUBBER	1	
5	3420	COUPLER, PUMP END		
6	3416	ADAPTOR, PUMP	1	
7	13375	PUMP, EATON	1	
8	0166 A	WASHER, LOCK, 3/8" MED	1	
9	EM963610	CAPSCREW 3/8-NC X 1-1/4" GRD8	1	
10	981635	BOLT, HEX 1/2-13 X 1"	1	
11	6109180	WASHER, LOCK 1/2",	4	
12		WASHER, FLAT 3/8"	4	OBTAIN LOCALLY
13		BOLT, 3/8-16 X 1-1/4"	4	OBTAIN LOCALLY
14	13289	BAR, MOTOR MOUNT	2	
15	124	WIRE, 12-4 ELECTRICAL, 28" L.....	3	1PC=1FT
16	940547	RECEPTACLE (L6-30P) 1 PH. 230 VOLT	1	
16	511647	RECEPTACLE (L15-30P) 3 PH. 230 VOLT	1	
16	EM98285	RECEPTACLE (L16-30P) 3 PH. 460 VOLT	1	
17	124	WIRE, 12-4 ELECTRICAL, 35" L.....	3	1PC=1FT
18		WASHER, FLAT 3/8"	7	OBTAIN LOCALLY
19		SCREW, 3/8-16 X 1-1/4"	4	OBTAIN LOCALLY
20	EM98187	SWITCH ASSY., 230V 1 PH.	1	
20	EM98191	SWITCH ASSY., 230V 3 PH.	1	
20	EM98284	SWITCH ASSY., 460V 3 PH.	1	
21	TBD	RING	2	
22	TBD	NUT	2	
23		BOLT, 1/4-20 X 1"	2	OBTAIN LOCALLY
24		WASHER, FLAT 1/4"	2	OBTAIN LOCALLY
25		WASHER, LOCK 1/4"	2	OBTAIN LOCALLY
26		NUT, 1/4-20.....	2	OBTAIN LOCALLY
27	3414	MOTOR, ELEC 5HP, 1 PH.	1	
27	3481	MOTOR, ELEC 5HP, 3 PH.	1	
28		WASHER, LOCK 3/8"	15	OBTAIN LOCALLY
29		NUT, 3/8-16.....	4	OBTAIN LOCALLY
30		BOLT, 3/8-16 X 3/4"	3	OBTAIN LOCALLY

FUEL TANK ASSY.

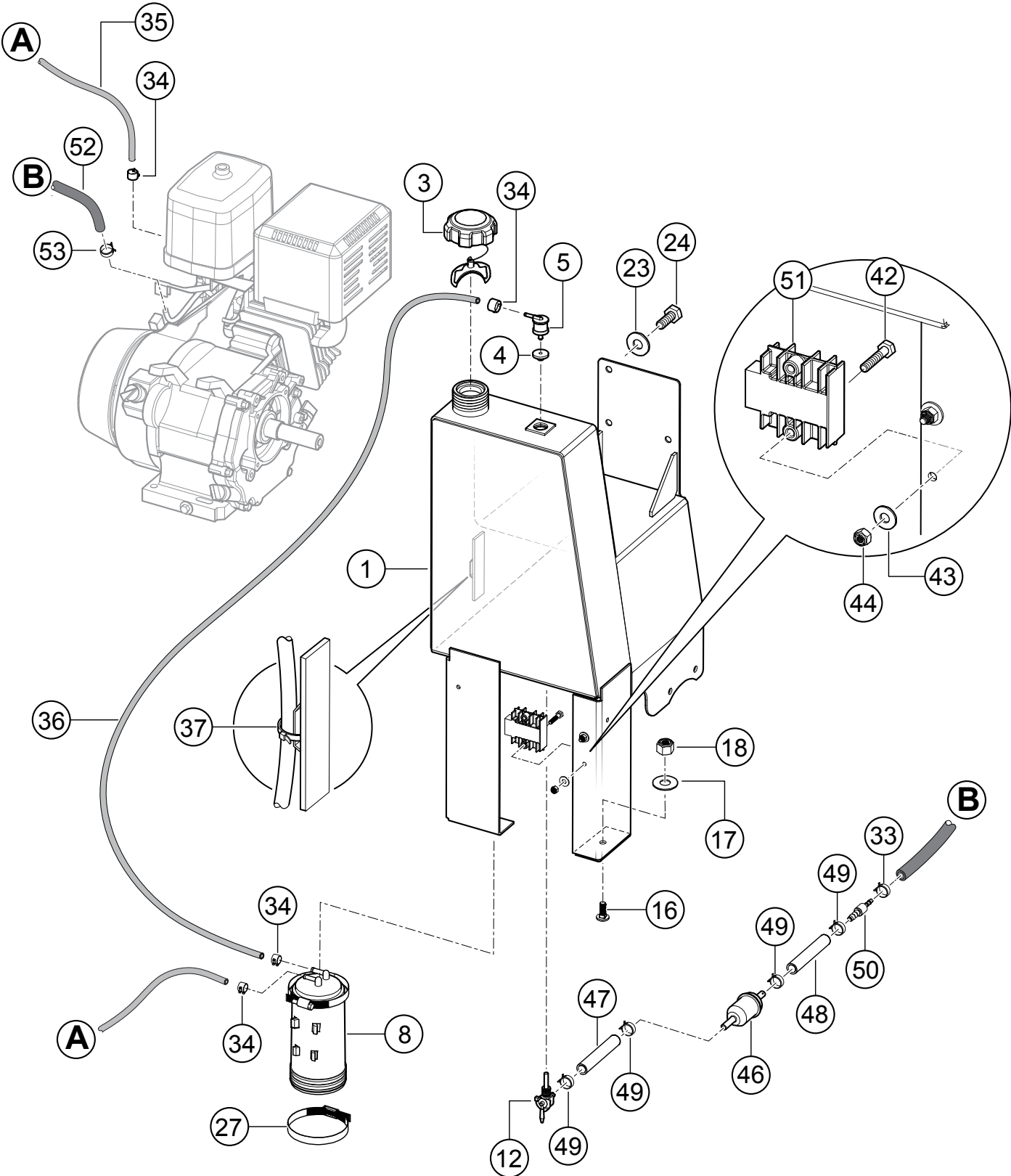

FUEL TANK ASSY.

<u>NO.</u>	<u>PART NO.</u>	<u>PART NAME</u>	<u>QTY.</u>	<u>REMARKS</u>
1	802353	TANK, GASOLINE	1	
3	520820	CAP, FUEL EPA	1	
4	203403	GROMMET, ROLL OVER VALVE	1	
5	202772	VALVE, ROLL OVER	1	
8	23506	CANISTER, CARBON, 800CC	1	
12	22081	VALVE, FUEL SHUTOFF	1	
16	504586	BOLT, 3/8-NC X 1" GRD5	2	
17	0166 A	WASHER, LOCK 3/8"	2	
18	EM969013	NUT, NYLOC 3/8-NC	2	
23	0166 A	WASHER, LOCK 3/8"	3	
24	EM963055	HEX HEAD CAPSCREW	3	
27	493108	CLAMP	2	
33	802573	CLAMP, BAND TENSION D=9.5	1	
34	802498	CLAMP, BAND TENSION D=11.1	4	
35	520833	HOSE, GASOLINE, EPA 3/16" X 0.96M 40"L....4.....	4	1PC=1FT
36	520833	HOSE, GASOLINE, EPA 3/16" X 0.73M 25"L....3.....	3	1PC=1FT
37	EM491028	WRAP, CABLE TIE, BLACK	2	
42	EM492358	BOLT, 1/4-NC X 1-1/4" GRD5	2	
43	EM923057	WASHER, 1/4"	2	
44	492581	NUT, 1/4-20 NYLOK	2	
46	EM20763	FILTER, FUEL IN-LINE	1	
47	520611	HOSE, GASOLINE, EPA 1/4" X 0.051M 2"L.....1.....	1	1PC=1FT
48	520611	HOSE, GASOLINE, EPA 1/4" X 0.076M 2"L.....1.....	1	1PC=1FT
49	802574	CLAMP, BAND TENSION D=11.7	4	
50	802405C	REDUCER, 1/4" - 3/16"	1	
51	31600ZE2861	REGULATOR	1	
52	91424Z5L822	TUBE, FUEL 4.5 X 580MM	1	
53	950024080008	CLAMP, TUBE	1	

PARTS MANUAL

HERE'S HOW TO GET HELP

PLEASE HAVE THE MODEL AND SERIAL
NUMBER ON-HAND WHEN CALLING

UNITED STATES

Multiquip Inc.

(310) 537- 3700
6141 Katella Avenue Suite 200
Cypress, CA 90630
E-MAIL: mq@multiquip.com
WEBSITE: www.multiquip.com

CANADA

Multiquip

(450) 625-2244
4110 Industriel Boul.
Laval, Quebec, Canada H7L 6V3
E-MAIL: infocanada@multiquip.com

UNITED KINGDOM

Multiquip (UK) Limited Head Office

0161 339 2223
Unit 2, Northpoint Industrial Estate,
Globe Lane,
Dukinfield, Cheshire SK16 4UJ
E-MAIL: sales@multiquip.co.uk

© COPYRIGHT 2020, MULTIQUIP INC.

Multiquip Inc, the MQ logo are registered trademarks of Multiquip Inc. and may not be used, reproduced, or altered without written permission. All other trademarks are the property of their respective owners and used with permission.

This manual MUST accompany the equipment at all times. This manual is considered a permanent part of the equipment and should remain with the unit if resold.

The information and specifications included in this publication were in effect at the time of approval for printing. Illustrations, descriptions, references and technical data contained in this manual are for guidance only and may not be considered as binding. Multiquip Inc. reserves the right to discontinue or change specifications, design or the information published in this publication at any time without notice and without incurring any obligations.

