

# PARTS MANUAL



## ***ESSICK* SERIES**

### **MODEL PRO20**

#### **HYDRAULIC PLASTER/MORTAR MIXER**

**(VANGUARD 18HP GASOLINE ENGINE)**

Revision #3 (04/22/25)

To find the latest revision of this publication or associated operation manual, visit our website at: [www.multiquip.com](http://www.multiquip.com)



THIS MANUAL MUST ACCOMPANY THE EQUIPMENT AT ALL TIMES.

# TABLE OF CONTENTS

---

## **PRO20 Hydraulic Mixer**

Explanation Of Code In Remarks Column..... 4  
Suggested Spare Parts ..... 5

### **Component Drawings**

Nameplate And Decals ..... 6-7  
Paddle Blades Assembly ..... 8-9  
Drum Assembly ..... 10-11  
Hydraulic Assembly ..... 12-15  
Frame Assembly ..... 16-19  
Cover Assembly ..... 20-21  
Engine Assembly ..... 22-23  
Battery Assembly ..... 24-25  
Engine Service Parts Assembly..... 26-27

**NOTICE**  
Specifications and part numbers are subject to change without notice.



# EXPLANATION OF CODE IN REMARKS COLUMN

The following section explains the different symbols and remarks used in the Parts section of this manual. Use the help numbers found on the back page of the manual if there are any questions.

## NOTICE

The contents and part numbers listed in the parts section are subject to change without notice. Multiquip does not guarantee the availability of the parts listed.

## SAMPLE PARTS LIST

NO.	PART NO.	PART NAME	QTY.	REMARKS
1	12345	BOLT .....	1	INCLUDES ITEMS W/%
2%		WASHER, 1/4 IN. ....		NOT SOLD SEPARATELY
2%	12347	WASHER, 3/8 IN. ...	1	MQ-45T ONLY
3	12348	HOSE .....	A/R	MAKE LOCALLY
4	12349	BEARING .....	1	S/N 2345B AND ABOVE

## NO. Column

**Unique Symbols** — All items with same unique symbol (@, #, +, %, or >) in the number column belong to the same assembly or kit, which is indicated by a note in the “Remarks” column.

**Duplicate Item Numbers** — Duplicate numbers indicate multiple part numbers, which are in effect for the same general item, such as different size saw blade guards in use or a part that has been updated on newer versions of the same machine.

## NOTICE

When ordering a part that has more than one item number listed, check the remarks column for help in determining the proper part to order.

## PART NO. Column

**Numbers Used** — Part numbers can be indicated by a number, a blank entry, or TBD.

TBD (To Be Determined) is generally used to show a part that has not been assigned a formal part number at the time of publication.

A blank entry generally indicates that the item is not sold separately or is not sold by Multiquip. Other entries will be clarified in the “Remarks” Column.

## QTY. Column

**Numbers Used** — Item quantity can be indicated by a number, a blank entry, or A/R.

A/R (As Required) is generally used for hoses or other parts that are sold in bulk and cut to length.

A blank entry generally indicates that the item is not sold separately. Other entries will be clarified in the “Remarks” Column.

## REMARKS Column

Some of the most common notes found in the “Remarks” Column are listed below. Other additional notes needed to describe the item can also be shown.

**Assembly/Kit** — All items on the parts list with the same unique symbol will be included when this item is purchased.

Indicated by:

“INCLUDES ITEMS W/(unique symbol)”

**Serial Number Break** — Used to list an effective serial number range where a particular part is used.

Indicated by:

“S/N XXXXX AND BELOW”

“S/N XXXX AND ABOVE”

“S/N XXXX TO S/N XXX”

**Specific Model Number Use** — Indicates that the part is used only with the specific model number or model number variant listed. It can also be used to show a part is NOT used on a specific model or model number variant.

Indicated by:

“XXXXX ONLY”

“NOT USED ON XXXX”

**“Make/Obtain Locally”** — Indicates that the part can be purchased at any hardware shop or made out of available items. Examples include battery cables, shims, and certain washers and nuts.

**“Not Sold Separately”** — Indicates that an item cannot be purchased as a separate item and is either part of an assembly/kit that can be purchased, or is not available for sale through Multiquip.

# SUGGESTED SPARE PARTS

---

## PRO20 HYDRAULIC MIXER WITH VANGUARD 18 HP ENGINE

1 to 3 units

Qty.	P/N	Description
1.....	807692.....	KIT, RUBB. BLADES, SCRAPERS AND HWD.
6.....	802366.....	URETHANE SEAL
2.....	802368.....	COVER, SEAL
2.....	691959.....	KEYSET, IGNITION
1.....	29173-001 .....	SWITCH, PUSH-PULL, W/O KNOB
1.....	29174-001 .....	KNOB-MUSHROOM
1.....	491010.....	LATCH KIT, ENGINE HOUSING
1.....	3353.....	CAP, FILLER/BREATHER
3.....	394018S .....	AIR FILTER
3.....	272490S .....	PRE-CLEANER
3.....	496018S .....	SPARK PLUG, CHAMPION
3.....	845125.....	IN-LINE FUEL FILTER
2.....	508667.....	ELEMENT, OIL, HYDRAULIC

### NOTICE

Part numbers on this Suggested Spare Parts list may supersede/replace the part numbers shown in the following parts lists.

# NAMEPLATE AND DECALS

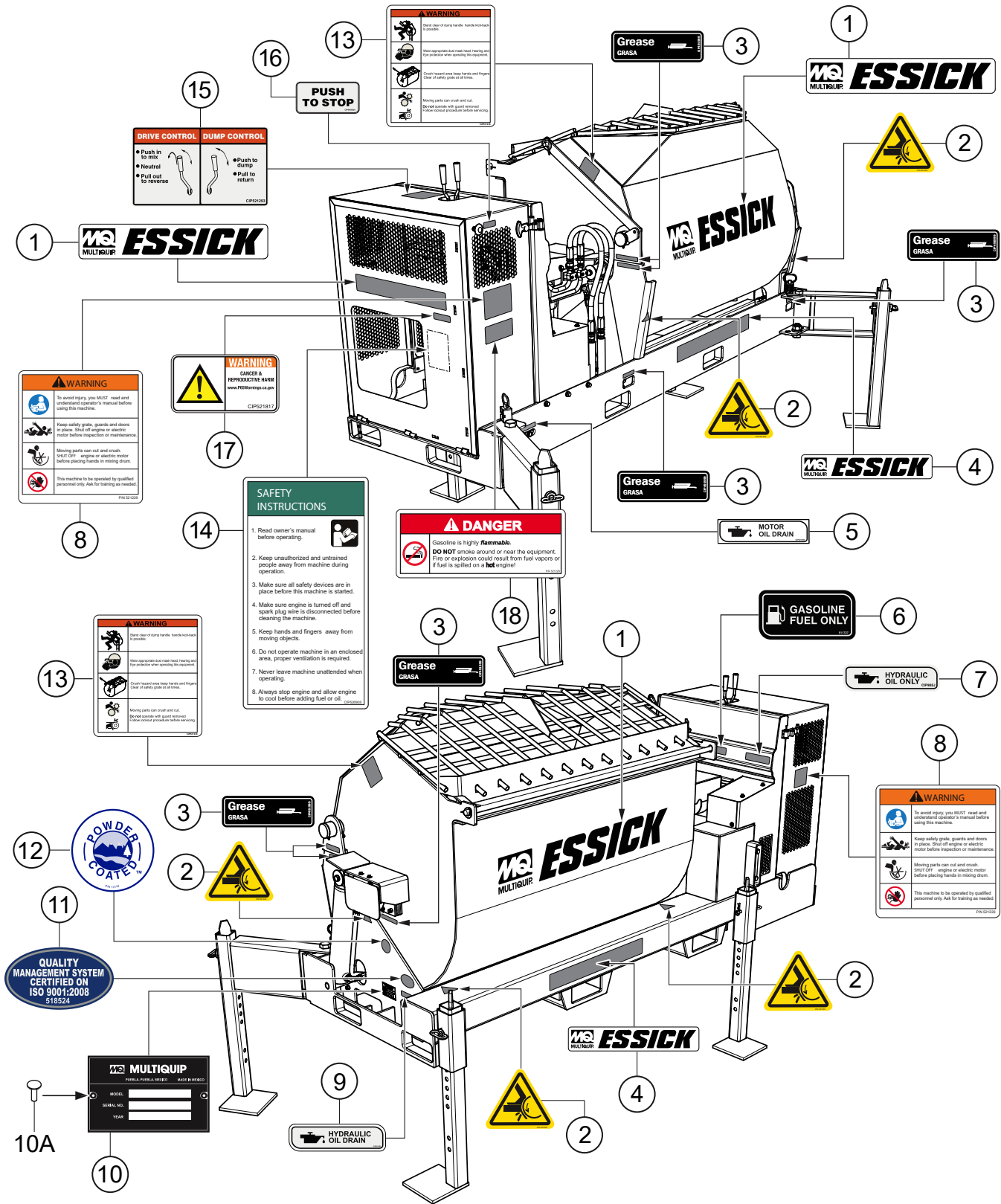

## NAMEPLATE AND DECALS

<u>NO.</u>	<u>PART NO.</u>	<u>PART NAME</u>	<u>QTY.</u>	<u>REMARKS</u>
1	EM510883	DECAL: ESSICK LG	1	
2	521303	DECAL: PINCH POINT	5	
3	491999	DECAL: GREASE	6	
4	EM510891	DECAL: MQ ESSICK MEDIUM	2	
5	521292	DECAL: MOTOR OIL DRAIN	1	
6	511727	DECAL: GASOLINE FUEL ONLY	1	
7	EM985	DECAL: HYDRAULIC OIL ONLY PLASTIFIED	1	
8	521229	DECAL: WARNING	2	
9	521291	DECAL: HYDRAULIC OIL DRAIN	1	
10	948008	PLATE, SERIAL NUMBER.....	1	.....CONTACT MQ PARTS DEPT.
10A	491757	POP RIVET	2	
11	518524	DECAL: ISO 9001:2000 EXPORT	1	
12	513118	DECAL: POWDER COATED	1	
13	521230	DECAL: PREVENT ACCIDENTS	2	
14	520935	DECAL: SAFETY INSTRUCTIONS	1	
15	521293	DECAL: DRIVE/DUMP CONTROL	1	
16	EM948630	DECAL: PUSH TO STOP	1	
17	521817	DECAL: WARNING CANCER CA PROP. 65	1	
18	521228	DECAL: DANGER GAS IS HIGHLY FLAMABL.	1	

# PADDLE BLADES ASSY.

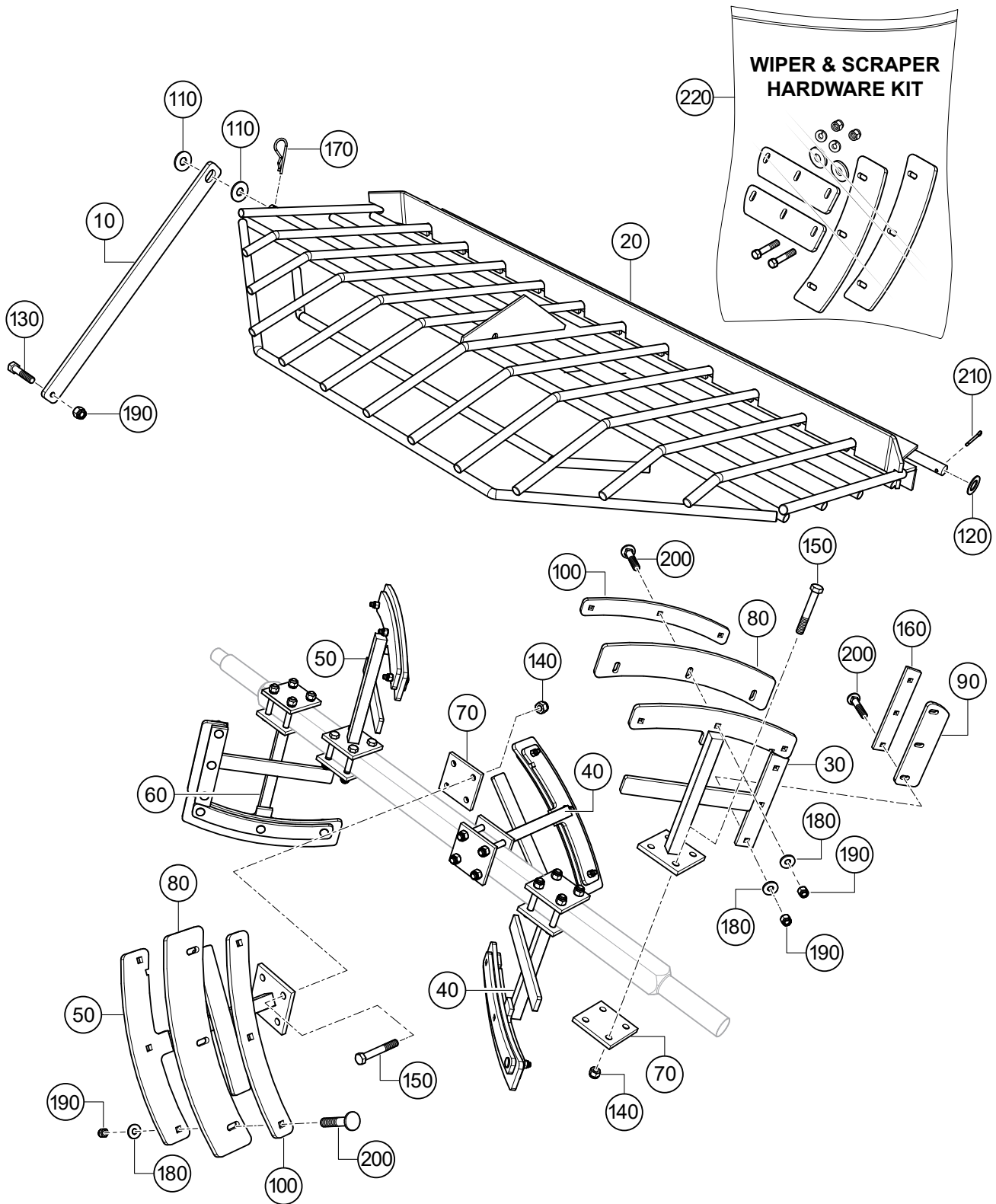



## PADDLE BLADES ASSY.

<u>NO.</u>	<u>PART NO.</u>	<u>PART NAME</u>	<u>QTY.</u>	<u>REMARKS</u>
10	807499	BAR, GRATE LATCH	1	
20	807388	GRATE	1	
30	802452	PADDLE ARM, END	1	
40	802453	PADDLE ARM, CENTER	2	
50	802454	PADDLE ARM, CENTER ENGINE END	2	
60	802455	PADDLE ARM, ENGINE END	1	
70	802443	RETAINER BASE, PADDLE ARM	6	
80\$	802447	RUBBER BLADE, SIDE	6	
90\$	802448	RUBBER BLADE END	2	
100\$	802451	STEEL BLADE, SIDE	6	
110	492602	WASHER, FLAT 5/8"	2	
120	507444	WASHER, FLAT 3/4" (SPACER)	2	
130	492378	HEX HD. BOLT 3/8" X 1-3/4" NC	1	
140	492584	NYLON INSERT NUT 1/2" NC GRD 5	24	
150	492400	HEX HD. BOLT 1/2" X 3-1/2" NC GRD 5	24	
160\$	802449	STEEL BLADE, END	2	
170	EM745	HAIR PIN 5/8-3/4"	1	
180\$	492598	FLAT WASHER 3/8"	24	
190\$	492583	NYLON INSERT NUT 3/8" NC	25	
200\$	505883	SCREW, 3/8-NC X 2" GRD5	24	
210	491692	PIN COTTER 3/16" X 1.1/4" G. (CAD)	2	
220	807692	KIT, RUBBER BLADES, SCRAPERS, HWD. ....1.....		INCLUDES ITEMS W/\$

# DRUM ASSY.

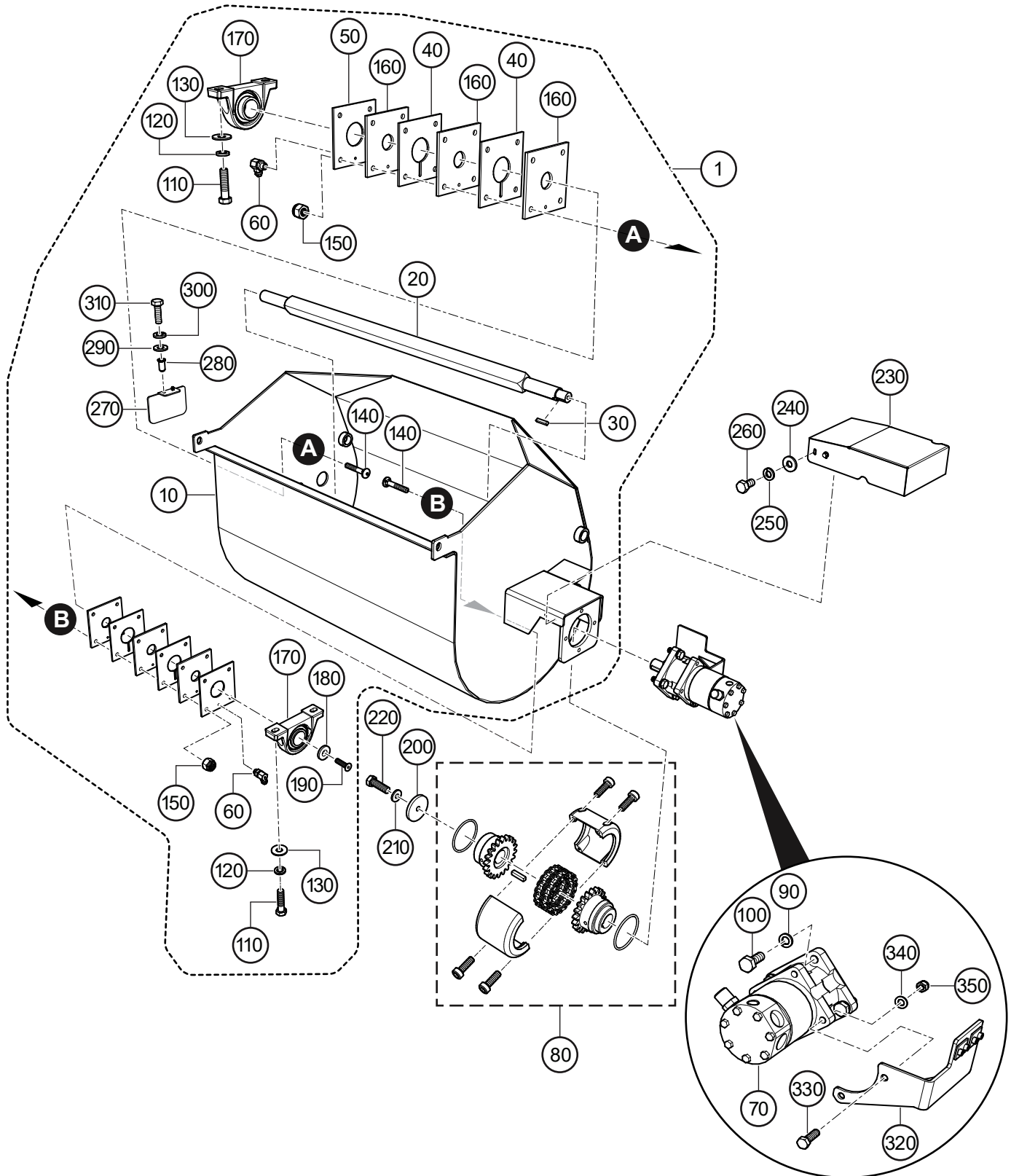

# DRUM ASSY.

<u>NO.</u>	<u>PART NO.</u>	<u>PART NAME</u>	<u>QTY.</u>	<u>REMARKS</u>
1	TBD	DRUM AND SHAFT ASSY.....	1.....	INCLUDES ITEMS W/@
10@	807372	DRUM, BARE 20 CU. FT.	1	
20@	807373	DRUM SHAFT	1	
30@	500461	WEDGE 3/8" X 40 MM	1	
40@	802367	SEPARATOR SHAFT SEALS	4	
50@	802368	SHAFT SEALS COVER	2	
60@	491704	90° FITTING ZERK 1/4" NF	2	
70	807454	HYDRAULIC MOTOR	1	
80	807443	ROLLER CHAIN COUPLING	1	
90	492627	WASHER, LOCK 5/8"	4	
100	530298	HEX HD. BOLT 5/8" X 1-3/4" NC GRD 5	4	
110@	492396	HEX HD. BOLT 1/2" X 2" NC GRD 5	4	
120@	492626	WASHER, LOCK 1/2"	4	
130@	492599	WASHER, FLAT 1/2"	4	
140@	521312	BOLT 3/8" X 2.1/4" NC GRD 5	8	
150@	492583	NYLON INSERT NUT 3/8" NC G8	8	
160@	802366	URETHANE SEAL	6	
170@	802415	PILLOW BLOCK	2	
180@	802667	COUNTERSUNK WASHER 5/16"	1	
190@	506176	FLAT HD. BOLT 5/16" X 1" NC GRD 8.8	1	
200	807403	WASHER, FLAT 3/8" LARGE	1	
210	492598	WASHER, FLAT 3/8" SMALL	1	
220	492376	HEX HD. BOLT 3/8" X 1-1/4" NC GRD5	1	
230	807400	HYDRAULIC MOTOR COVER	1	
240	509161	WASHER, FLAT 5/16"	4	
250	492623	WASHER, LOCK 5/16"	4	
260	492362	HEX HD. BOLT 5/16" X 5/8" NC GRD 5	4	
270@	804004	COVER DRUM BEARING	1	
280@	DULT100602	BLIND RIVET NUT M6	2	
290@	492595	FLAT WASHER 1/4"	2	
300@	492622	LOCK WASHER 1/4"	2	
310@	DULT100255	HEX HD. BOLT M6 X 20 GRD 8.8	2	
320	807562	WELDING SUPPORT HYDRAULIC HOSES	1	
330	492396	HEX HD. BOLT 1/2" X 2" NC GRD 5	2	
340	504322	WASHER, FLAT 1/2".	2	
350	492584	NYLON INSERT NUT 1/2" NC GRD 5	2	

# HYDRAULIC ASSY.

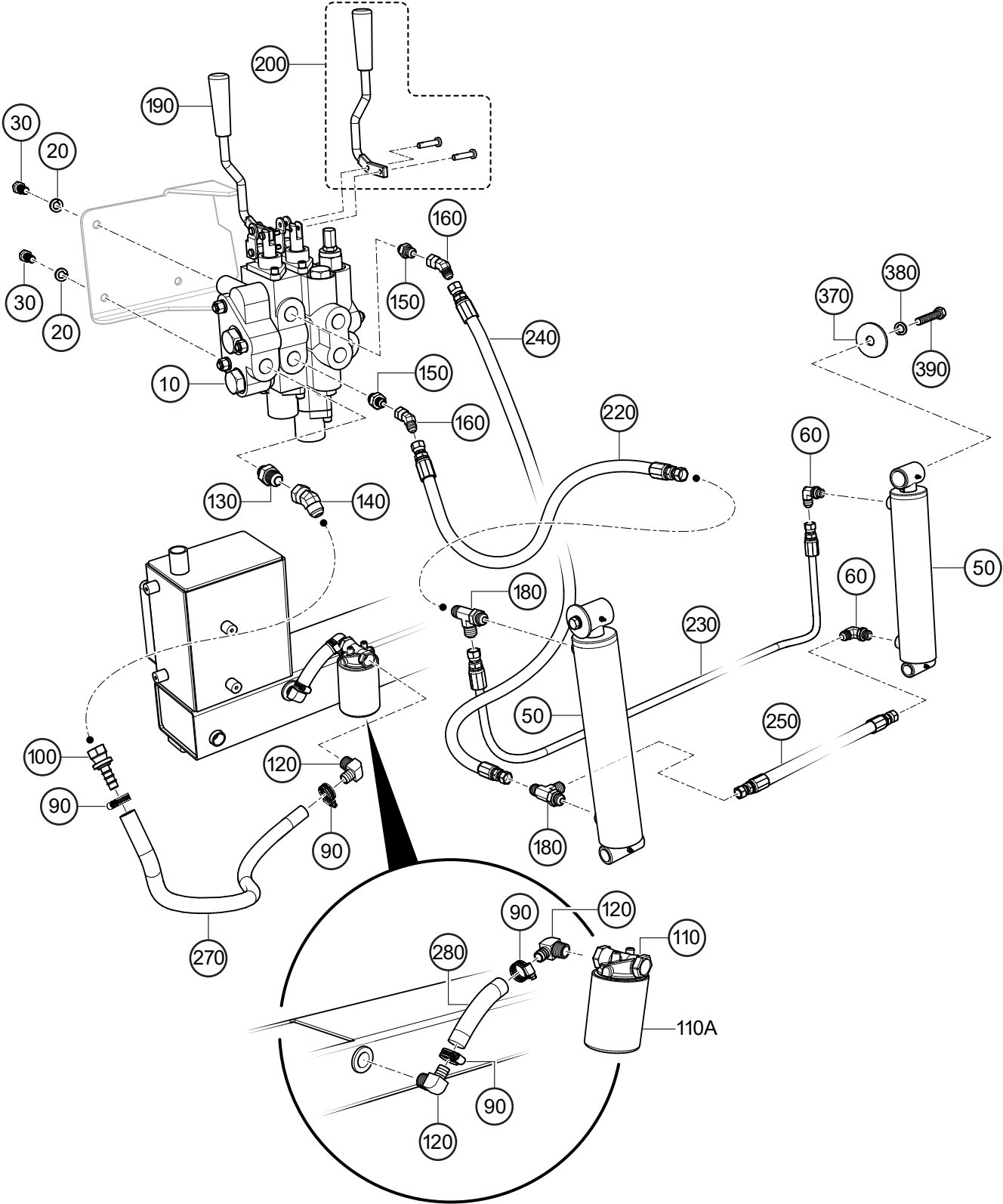

## HYDRAULIC ASSY.

<u>NO.</u>	<u>PART NO.</u>	<u>PART NAME</u>	<u>QTY.</u>	<u>REMARKS</u>
10	34585	VALVE, FOUR WAY	1	
20	0166A	WASHER, LOCK 3/8" .....	3	REPLACES P/N 492624
30	EM963055	HEX HD. BOLT 3/8" X 3/4" NC GRD 5 .....	3	REPLACES P/N 492373
50	802280	HYDRAULIC CYLINDER	2	
60	506196	FITTING, 90° 6 C5OX-S	2	
90	506207	WORM CLAMP	4	
100	511847	BARB FITTING	1	
110	522617	FILTER HEAD	1	
110A	508667	ELEMENT, HYD. OIL	1	
120	3367	FITTING, 90° 129HB-12-12	3	
130	803224	FITTING, STRAIGHT 12-8 F5OX-S	1	
140	518198	FITTING, 45° 12 V6X-S	1	
150	512190	FITTING, STRAIGHT 6-8 F5OX-S	2	
160	512234	FITTING, 45° 6 V6X-S	2	
180	802938	FITTING, TEE 6 R5OX-S	2	
190	803048	HANDLE, LEFT VALVE W/SCREWS	1	
200	803049	HANDLE, RIGHT VALVE W/SCREWS	1	
220	803001	HOSE, VALVE	1	
230	807441	HOSE, HYDRAULIC CYLINDER	1	
240	803003	HOSE, VALVE	1	
250	807438	HOSE, CYLINDER	1	
270	803006	HOSE, FILTER IN	1	
280	803007	HOSE, FILTER OUT	1	
370	530183	WASHER, FLAT 1/2"	2	
380	492626	WASHER, LOCK 1/2"	2	
390	492394	HEX HD. BOLT 1/2"NC X 1-1/2" G5	2	

# HYDRAULIC ASSY. CONT'D.

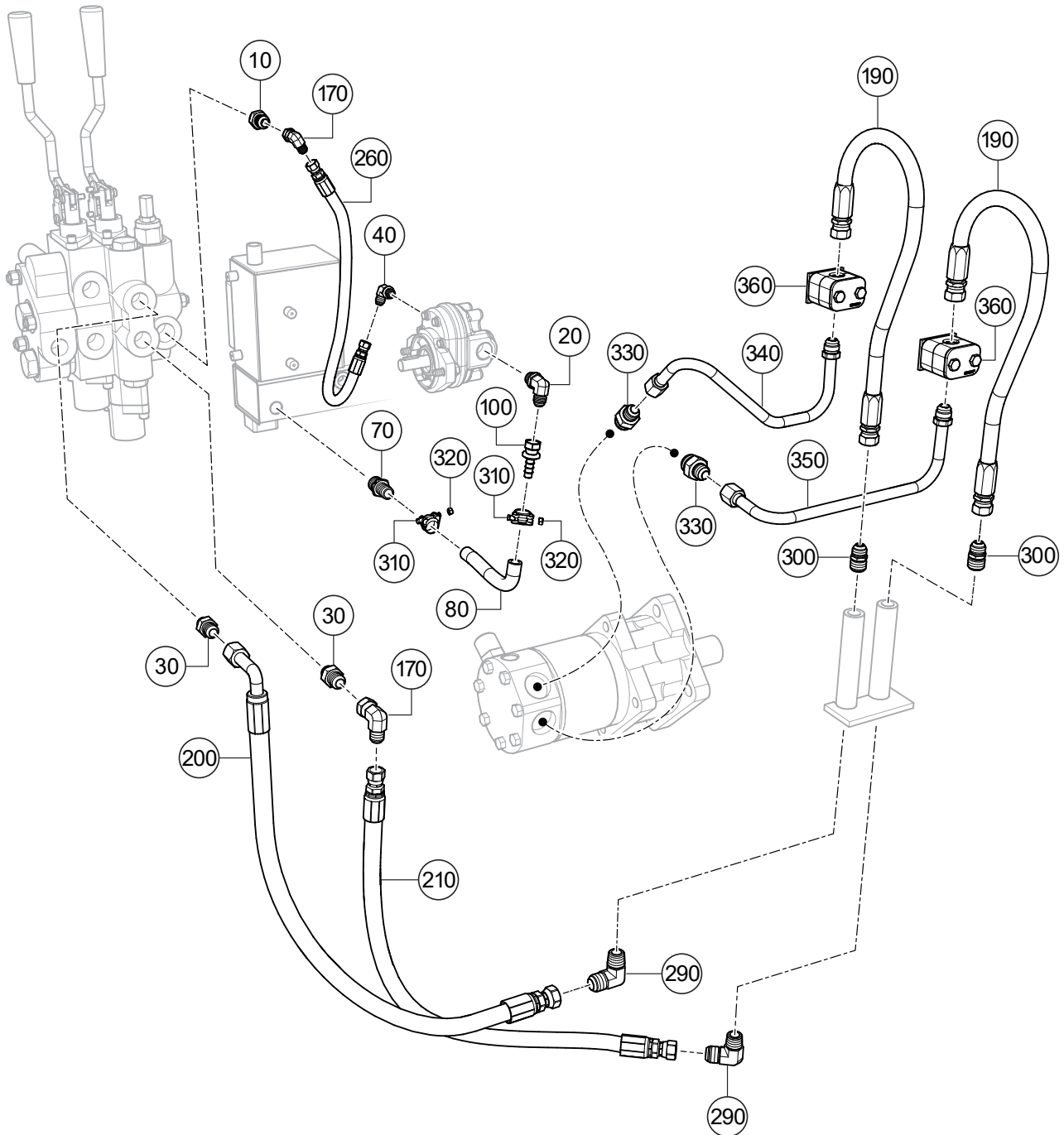

## HYDRAULIC ASSY. CONT'D.

---

<u>NO.</u>	<u>PART NO.</u>	<u>PART NAME</u>	<u>QTY.</u>	<u>REMARKS</u>
10	3365	FITTING, STRAIGHT 10 F50X-S	1	
20	514488	FITTING, 90° 12 CC50X-S	1	
30	3314	FITTING, STRAIGHT 10-8 F50X-S	2	
40	3322	FITTING, 90° 10 C50X-S	1	
70	13220	FITTING, STRAIGHT 125HBL-12-1	1	
80	807859	HOSE, SUCTION	1	
100	511847	BARB FITTING	1	
170	512201	FITTING, 90° 10 C6X-S	2	
190	803352	HOSE, HYDRAULIC MOTOR	2	
200	807440	HOSE, VALVE	1	
210	803353	HOSE, VALVE	1	
260	807439	HOSE, VALVE/HYD. MOTOR	1	
290	509784	FITTING, 90° 12CTX-S	2	
300	516675	FITTING, STRAIGHT 12 FTX-S	2	
310	804371	HIGH PRESSURE HOSE CLAMP 1-1/4"	2	
320	DULT100078	NYLON INSERT NUT M6	2	
330	513548	FITTING, STRAIGHT 10-12 F50X-S	2	
340	807502	PIPE, HYDRAULIC MOTOR	1	
350	807503	PIPE, HYDRAULIC MOTOR	1	
360	807560	HOSE/PIPE CLAMP 5/8"	2	

# FRAME ASSY.

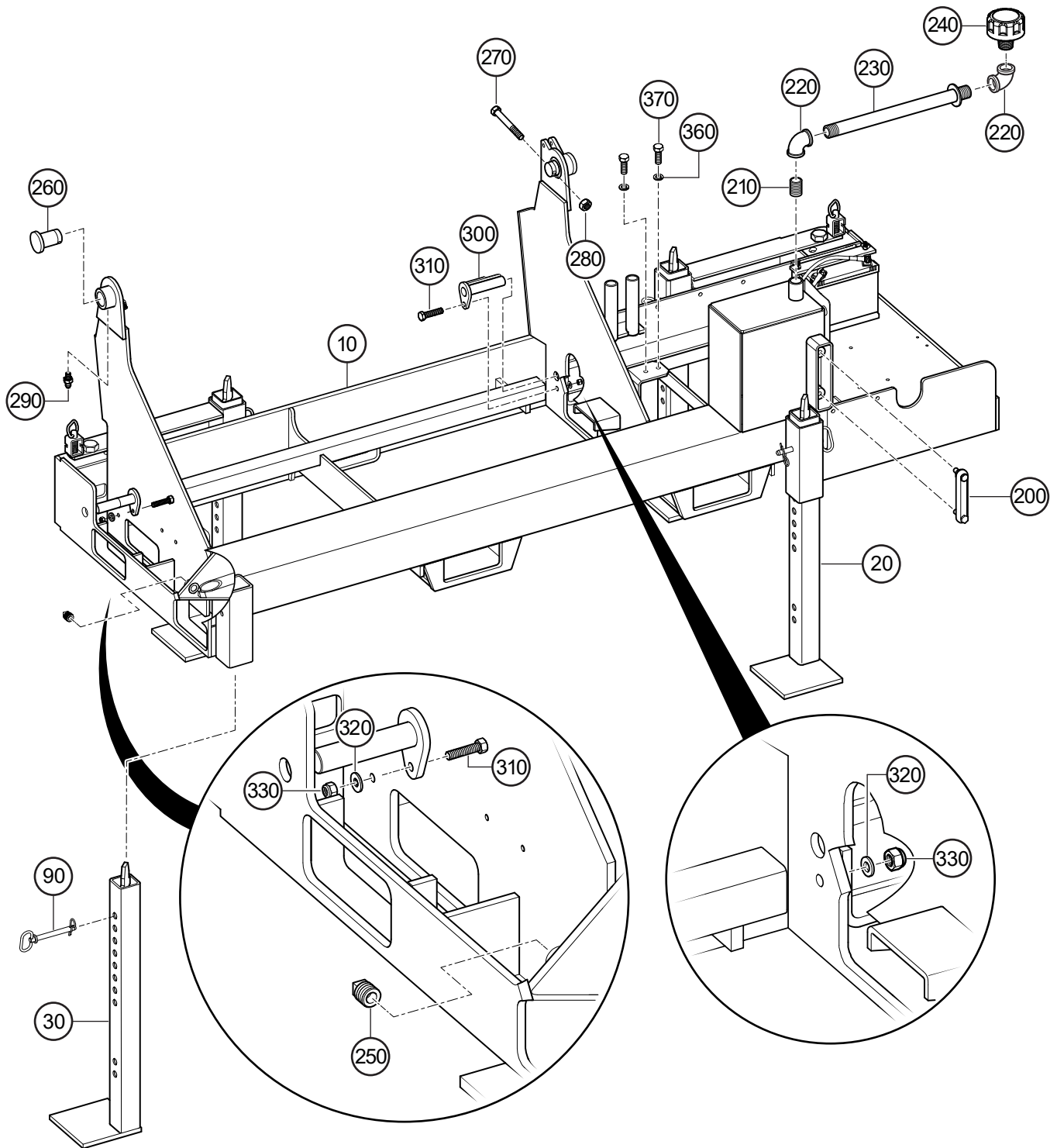



# FRAME ASSY.

---

<u>NO.</u>	<u>PART NO.</u>	<u>PART NAME</u>	<u>QTY.</u>	<u>REMARKS</u>
10	807361	FRAME	1	
20	807433	LEG, SUPPORT RIGHT	2	
30	807434	LEG, SUPPORT LEFT	2	
90	EM744	PIN, 1/2" X 4"	4	
200	18052	SIGHT GAUGE	1	
210	491189	NIPPLE, PIPE 1" NPT	1	
220	491160	90° ELBOW	2	
230	807578	PIPE, 1" NPT X 10" GALV.	1	
240	3353	CAP, FILLER/BREATHER	1	
250	506094	PLUG 1/2" NPT GALV.	1	
260	802362	CAP	2	
270	520894	BOLT 3/8" X 3" NC GRD 8.8	2	
280	492583	NUT, NYLOC 3/8" NC	2	
290	491705	ZERK FITTING 1/4" NF	2	
300	802363	RETAINER, CYLINDER	2	
310	492303	BOLT 5/16" X 1-1/4" NC GRD 5.....	2.....	REPLACES P/N 492365
320	492596	WASHER, FLAT 5/16"	2	
330	492582	NUT, NYLOC 5/16" NC	2	
360	492622	WASHER, LOCK 1/4"	2	
370	492356	BOLT 1/4" X 3/4"	2	

# FRAME ASSY. CONT'D.

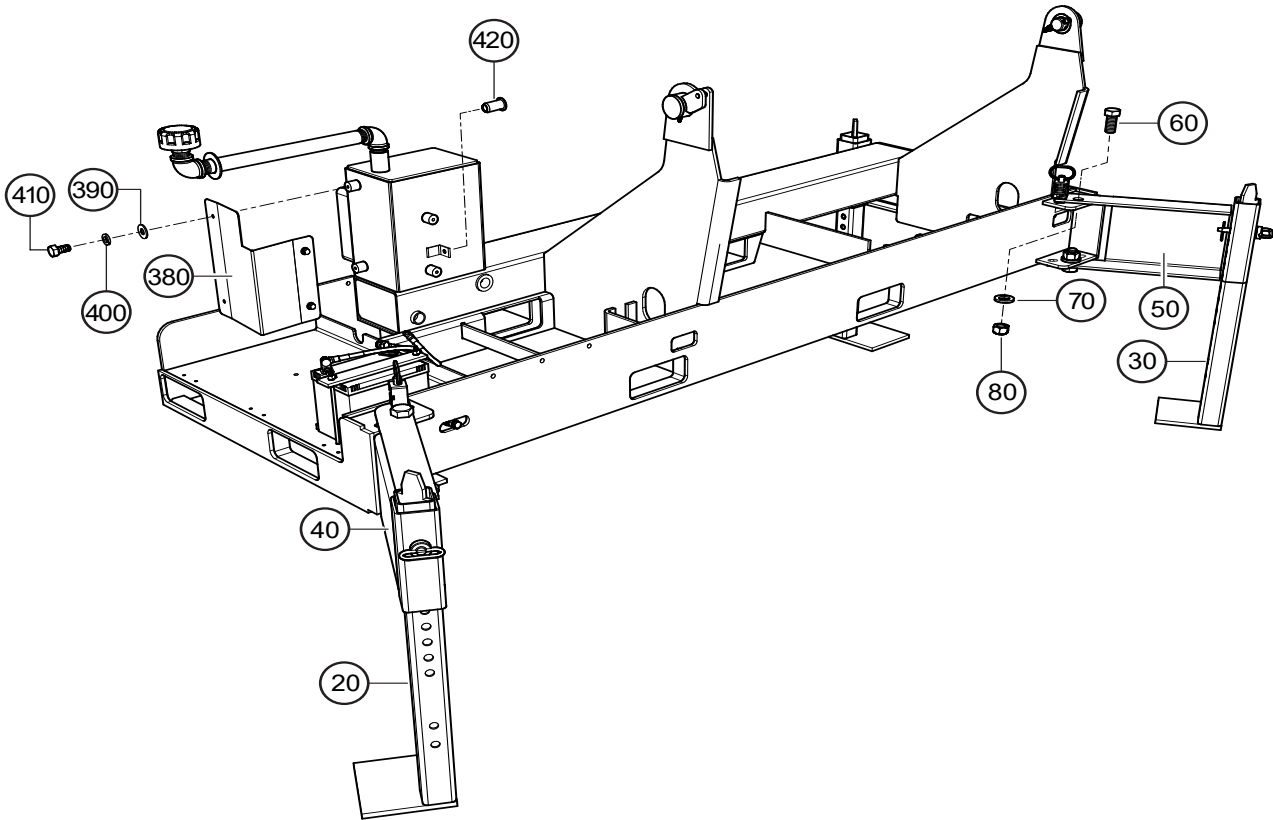

## FRAME ASSY. CONT'D.

---

<u>NO.</u>	<u>PART NO.</u>	<u>PART NAME</u>	<u>QTY.</u>	<u>REMARKS</u>
20	807433	LEG, SUPPORT RIGHT	2	
30	807434	LEG, SUPPORT LEFT	2	
40	802331	ARM, STABILIZER LEFT	1	
50	807393	ARM, STABILIZER RIGHT	1	
60	502125	BOLT, 1" X 2" NF GRD 5	4	
70	500089	WASHER, FLAT 1" GRD 5	4	
80	TK86D16	NUT, 1" NF	4	
380	807512	SHIELD, HYDRAULIC OIL TANK	1	
390	492596	WASHER, FLAT 5/16"	4	
400	492623	WASHER, LOCK 5/16"	4	
410	492362	BOLT 5/16" X 5/8" NC GRD 5	4	
420	DULT100602	BLIND NUT M6	1	

# COVER ASSY.

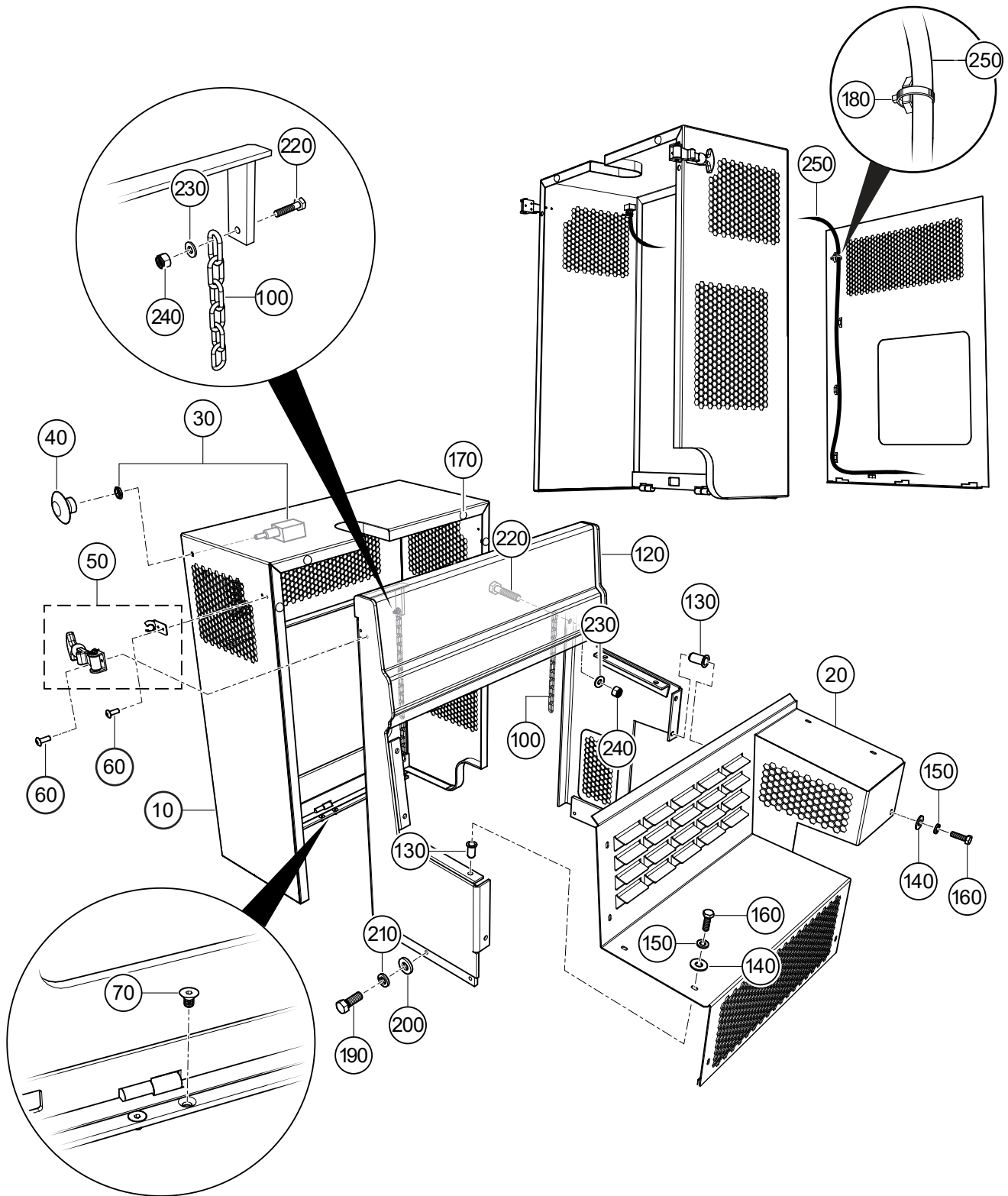

## COVER ASSY.

---

<u>NO.</u>	<u>PART NO.</u>	<u>PART NAME</u>	<u>QTY.</u>	<u>REMARKS</u>
10	807415	COVER MOVEABLE	1	
20	807428	COVER, FIXED	1	
30	29173-001	SWITCH, PUSH-PULL W/O KNOB	1	
40	29174-001	KNOB, MUSHROOM	1	
50	491010	RUBBER, HOOD FASTEN	2	
60	503723	POP RIVET	10	
70	510476	FLAT HD. BOLT 5/16" X 1/2" NC	6	
100	807573	CHAIN	1	
120	807425	FIXED COVER	1	
130	DULT100602	BLIND RIVET NUT M6	9	
140	492596	WASHER, FLAT 5/16"	10	
150	492622	WASHER, LOCK 1/4"	10	
160	DULT100255	HEX HD BOLT M6 X 20 GRD 8.8	10	
170	TK6597572	RUBBER BUMPER	4	
180	509699	CABLE TIE, BLACK	9	
190	492375	HEX HD. BOLT 3/8"X 1" NC G5	5	
200	506488	WASHER, FLAT 3/8"	5	
210	492624	WASHER, LOCK 3/8"	5	
220	506176	BOLT 5/16" X 1" NC GRD 8.8	1	
230	508344	WASHER, FLAT 5/16"	1	
240	492582J	NYLON INSERT NUT 5/16" NC GRD 8	1	
250	807563	WIRE HARNESS	1	

# ENGINE ASSY.

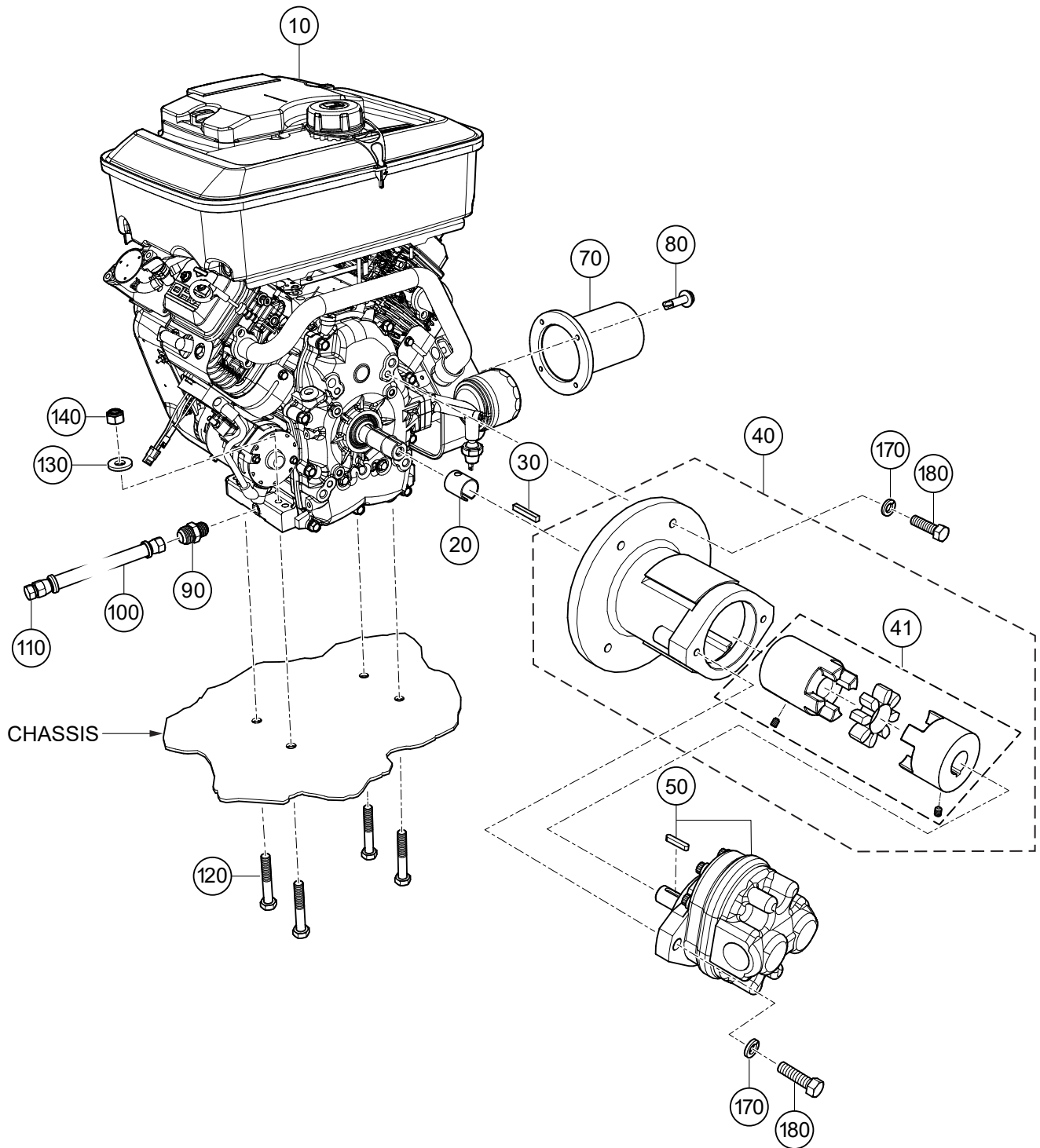

## ENGINE ASSY.

---

<u>NO.</u>	<u>PART NO.</u>	<u>PART NAME</u>	<u>QTY.</u>	<u>REMARKS</u>
10	807370	VANGUARD ENGINE 18 HP	1	
20	807608	SLEEVE ENGINE SHAFT	1	
30	500275	WEDGE 1/4" X 40 MM	1	
40	807579	COUPLING KIT.....	1.....	INCLUDES ITEMS W/#
41#	516282C	COUPLER ASSY.	1	
50	13374	PUMP, EATON	1	
70	807414	EXHAUST FLANGE	1	
80	801835	HEX BOLT W/WASHER 3/16" X 3/4"	4	
90	801501	STRAIGHT FITTING, DRAIN HOSE	1	
100	800776	HOSE, DRAIN	1	
110	513619	STRAIGHT FITTING, DRAIN HOSE	1	
120	492368	HEX HD. BOLT 5/16" X 2" NC GRD 5	4	
130	509161	WASHER, FLAT 5/16"	4	
140	492553	HEX NUT 5/16" NC GRD 5	4	
170	492624	WASHER, LOCK 3/8"	6	
180	492376	HEX HD. BOLT 3/8" X 1-1/4" NC G5	6	

**BATTERY ASSY.**

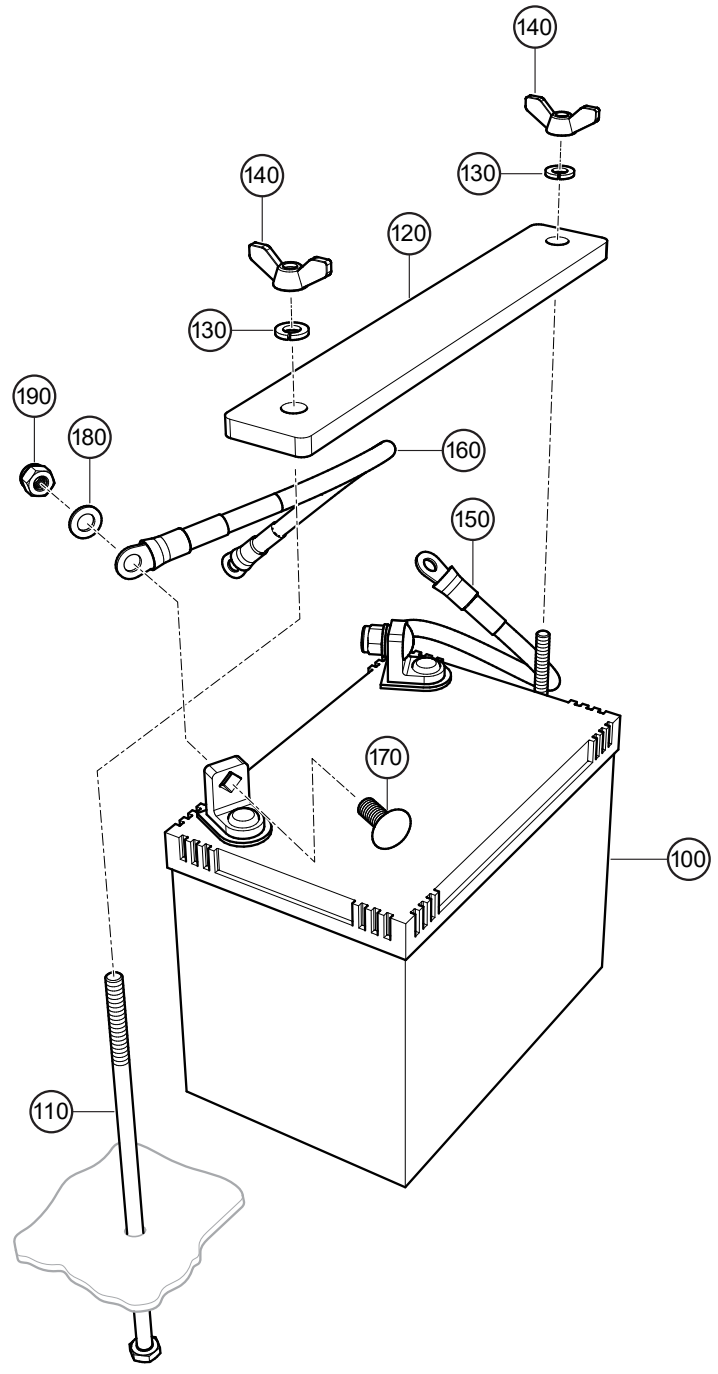



## BATTERY ASSY.

---

<u>NO.</u>	<u>PART NO.</u>	<u>PART NAME</u>	<u>QTY.</u>	<u>REMARKS</u>
100	4671	BATTERY 12V GROUP U1 WET CELL	1	
110	806921	BOLT 1/4" X 7-1/2" NC GRD 5	2	
120	802314	BATTERY TIE DOWN BRACKET	1	
130	492622	WASHER, LOCK 1/4"	2	
140	505500	WINGNUT 1/4" NC	2	
150	807426	CABLE, BATTERY POS (L= 1 FT/305 MM) .....	1	1PC = 1FT
160	807427	CABLE, BATTERY NEG (L= 1.5 FT/457 MM) ...	1	1PC = 1FT
170	966279	BOLT 5/16" X 3/4" NC GRD 5	2	
180	508344	WASHER, FLAT 5/16"	2	
190	492582	NUT, NYLOC 5/16"	2	

# ENGINE SERVICE PARTS ASSY.

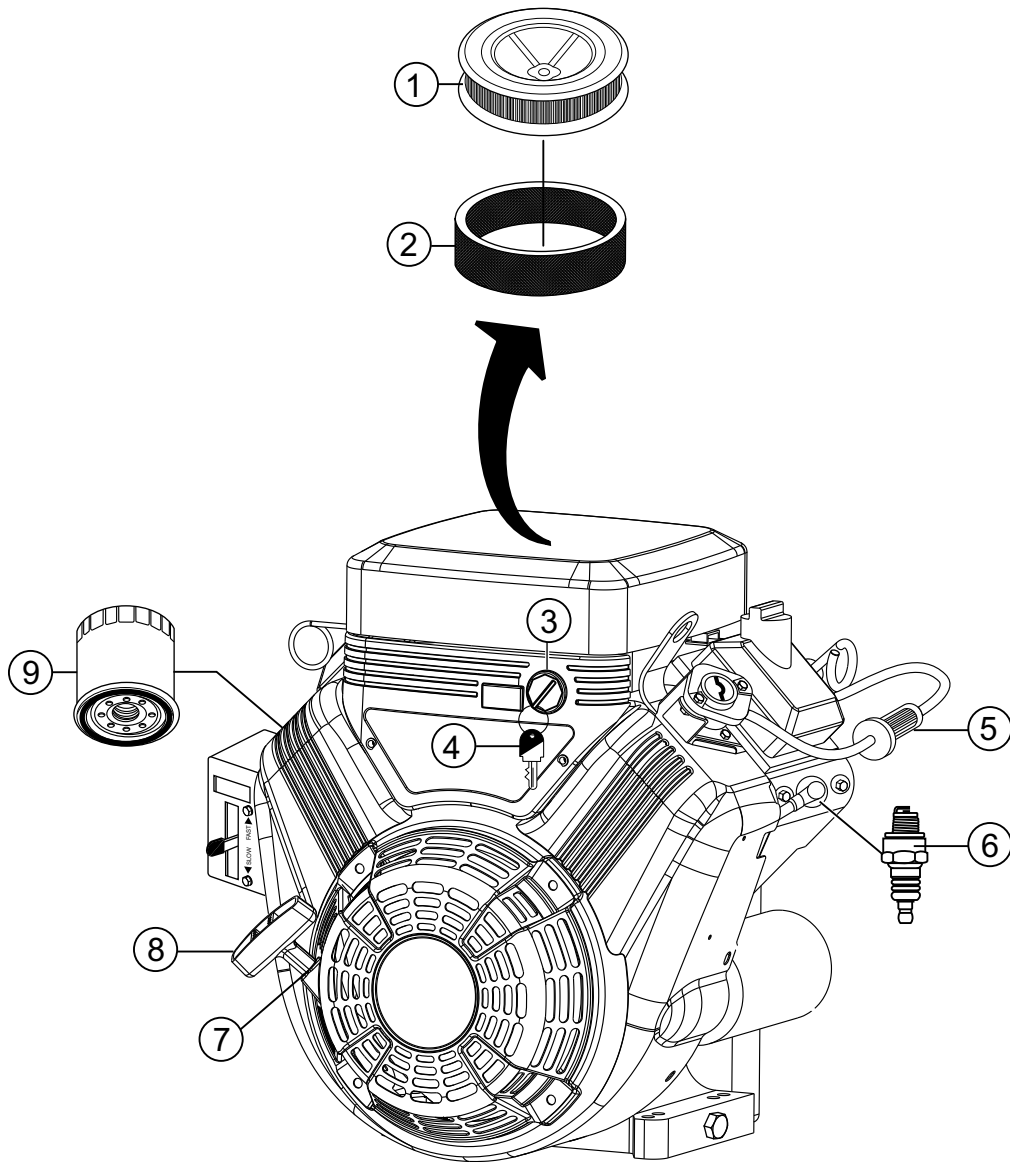

## ENGINE SERVICE PARTS ASSY.

---

<u>NO.</u>	<u>PART NO.</u>	<u>PART NAME</u>	<u>QTY.</u>	<u>REMARKS</u>
1	394018S	AIR FILTER	1	
2	272490S	PRE-CLEANER	1	
3	692318	IGNITION SWITCH, W/KEY	1	
4	691959	IGNITION KEY SET	2	
5	845125	IN-LINE FUEL FILTER	1	
6	496018S	SPARK PLUG, CHAMPION	2	
7	66574	ROPE, STARTER	1	
8	808167	GRIP, STARTER	1	
9	842921	OIL FILTER	1	

# PARTS MANUAL

## HERE'S HOW TO GET HELP

PLEASE HAVE THE MODEL AND SERIAL  
NUMBER ON-HAND WHEN CALLING

### UNITED STATES

#### *Multiquip Inc.*

(310) 537- 3700  
6141 Katella Avenue Suite 200  
Cypress, CA 90630  
E-MAIL: [mq@multiquip.com](mailto:mq@multiquip.com)  
WEBSITE: [www.multiquip.com](http://www.multiquip.com)

---

### CANADA

#### *Multiquip*

(450) 625-2244  
4110 Industriel Boul.  
Laval, Quebec, Canada H7L 6V3  
E-MAIL: [infocanada@multiquip.com](mailto:infocanada@multiquip.com)

### UNITED KINGDOM

#### *Multiquip (UK) Limited Head Office*

0161 339 2223  
Unit 2, Northpoint Industrial Estate,  
Globe Lane,  
Dukinfield, Cheshire SK16 4UJ  
E-MAIL: [sales@multiquip.co.uk](mailto:sales@multiquip.co.uk)

© COPYRIGHT 2025, MULTIQUIP INC.

Multiquip Inc. and the MQ logo are registered trademarks of Multiquip Inc. and may not be used, reproduced, or altered without written permission. All other trademarks are the property of their respective owners and used with permission.

This manual MUST accompany the equipment at all times. This manual is considered a permanent part of the equipment and should remain with the unit if resold.

The information and specifications included in this publication were in effect at the time of approval for printing. Illustrations, descriptions, references and technical data contained in this manual are for guidance only and may not be considered as binding. Multiquip Inc. reserves the right to discontinue or change specifications, design or the information published in this publication at any time without notice and without incurring any obligations.

