



QP15HP

MULTIQUIP® 1.5" High Pressure Pump

GALLONS PER MINUTE

56 (212 L)

HEAD

197 ft (60 M)

ENGINE

Honda GXH50



APPLICATIONS

Agricultural - Construction Sites - Emergency Response - Excavation - Farms - Floods - Irrigation - Jobsite - Drainage - Mining - Municipalities - Standing Water - Swimming Pools - Quarries - Water Departments - Water Supply from Lakes/Rivers

STANDARD FEATURES

- Maximum pumping capacity of **56 gallons (212 liters) per minute.**
- Maximum lift of **25 feet (7.6 meters).**
- Aluminum body and fittings.
- High-Efficiency impeller and volute for maximum fluid transfer.
- Open die-cast aluminum impeller and die cast aluminum volute for **extreme high-pressure performance.**
- Ceramic carbide mechanical seal provides **extreme abrasion resistance** and **high temperature operation.**
- Bi-directional outlet provides ultimate convenience and adaptability.
- 3/4" (19.1 mm) diameter fill and drain ports.
- Engine oil-alert to protect the engine in the case of low engine oil.
- Heavy-duty carrying handle made of 7/8" (20.2 mm) tubular steel.

WARRANTY*

QP15HP: 24 months from date of purchase.

Honda GXH50 Engine: 12 months from date of purchase.

Hoses: 3 months from date of purchase.

*Refer to the MULTIQUIP NEW PRODUCT LIMITED WARRANTY FOR FULL TERMS AND CONDITIONS.

FEATURES

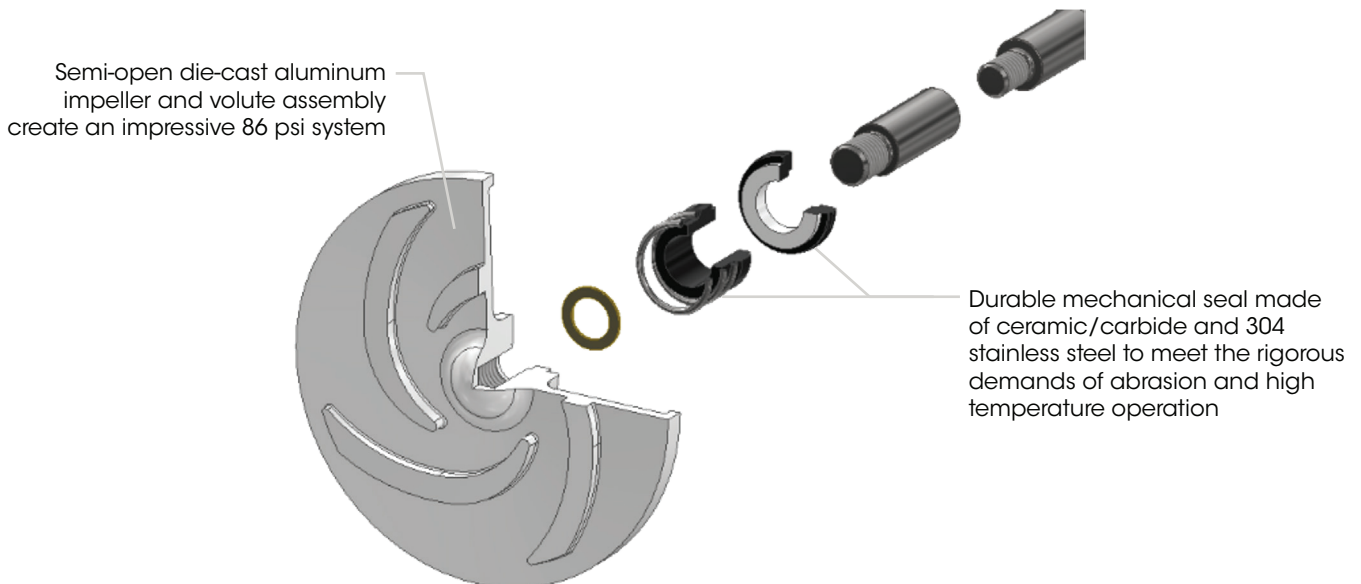
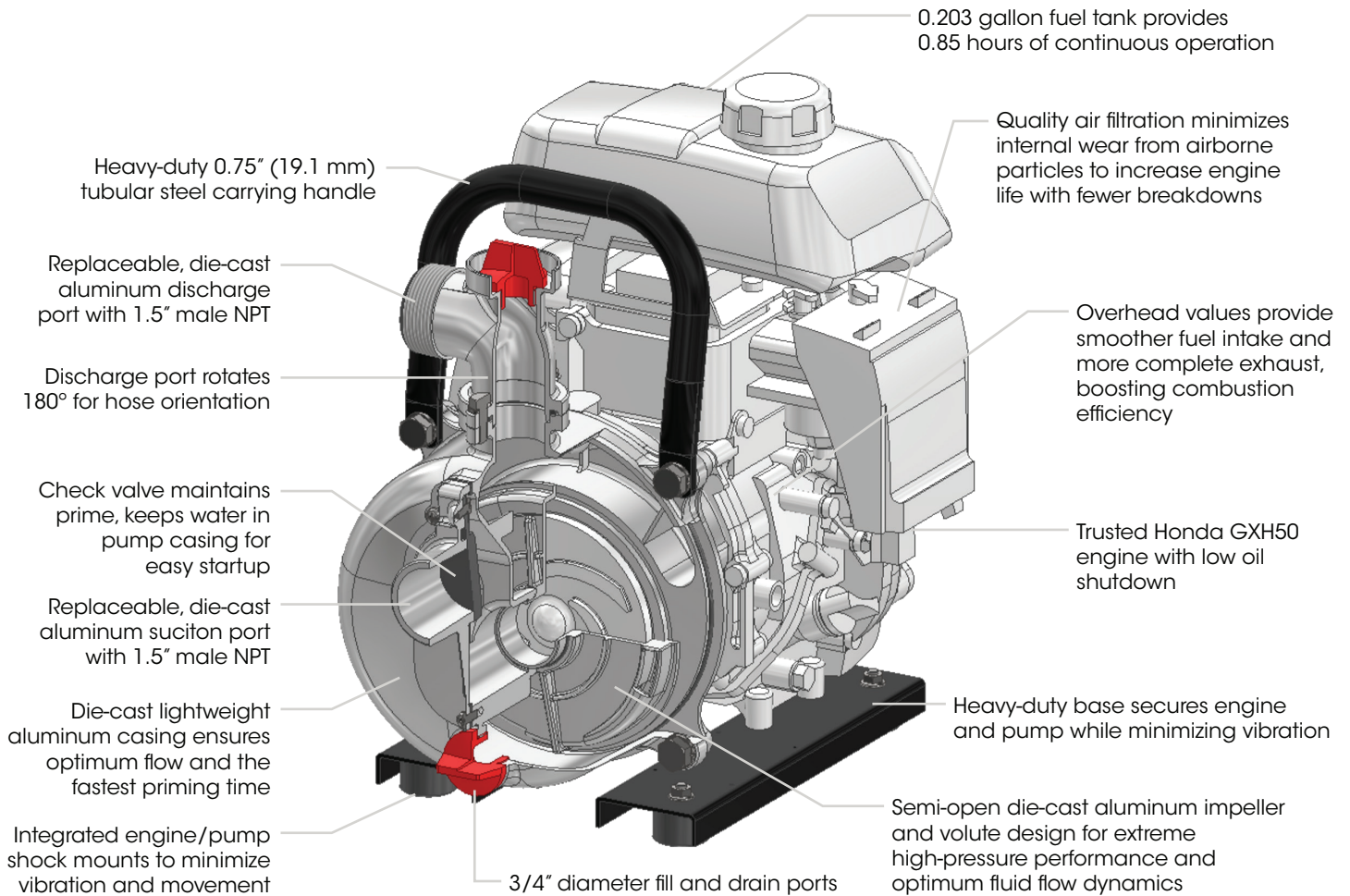

© COPYRIGHT 2026 MULTIQUIP INC. (REV 04012026)

PUMP CURVE

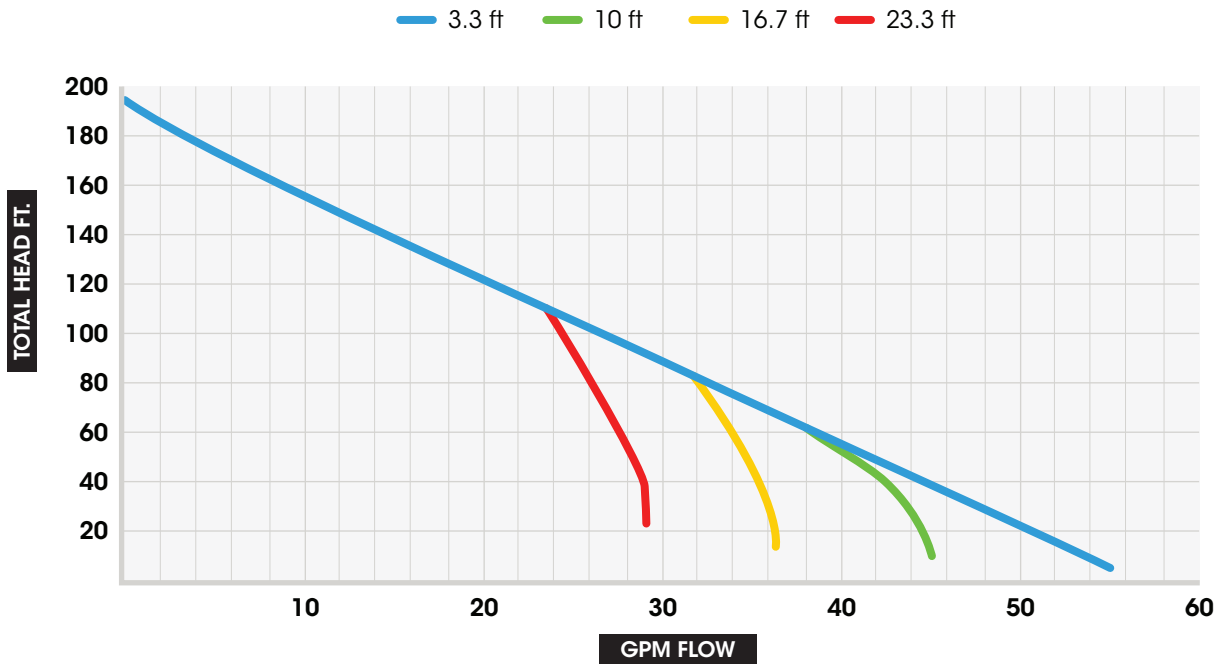

PUMP DIMENSIONS

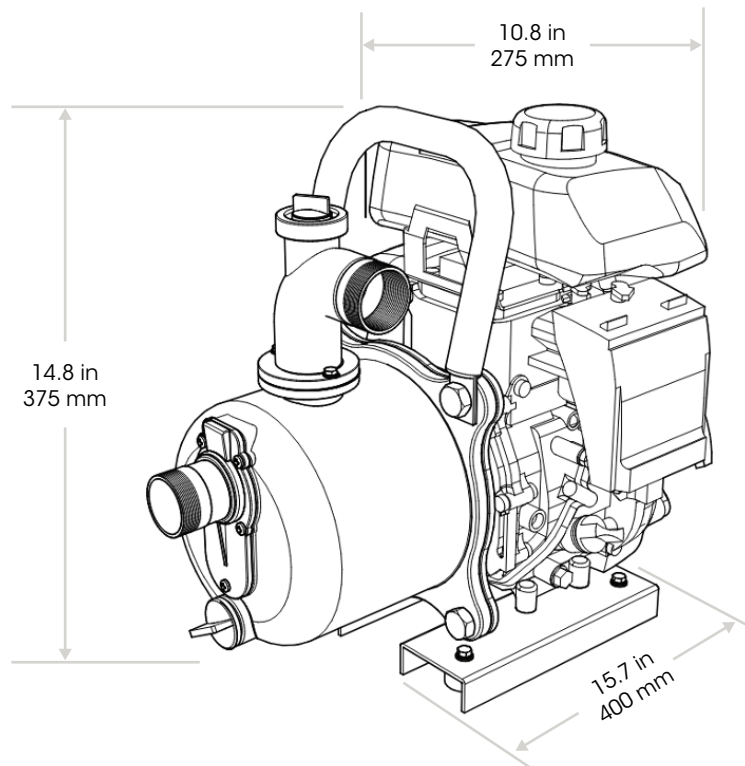

SPECIFICATIONS

PUMP SPECIFICATIONS	
MODEL	QP15HP
TYPE	CENTRIFUGAL HIGH-PRESSURE PUMP
IMPELLER TYPE	SEMI-OPEN
MAX. PUMP CAPACITY	56 GALLONS/MINUTE (212 L/MIN)
MAX. SUCTION	25 ft (7.62 M)
MAX. HEAD	197 ft (60 M)
SUCTION PORT SIZE	1.5 in (38.1 mm)
DISCHARGE PORT SIZE	1.5 in (38.1 mm)
THREAD TYPE	NPT (MALE)
PSI	86
IMPELLER MATERIAL	DIE-CAST ALUMINUM
VOLUTE MATERIAL	DIE-CAST ALUMINUM
PUMP CASING MATERIAL	DIE-CAST ALUMINUM
CHECK VALVE MATERIAL	NITRILE BUTADIENE RUBBER
MECHANICAL SEAL MATERIAL	CERAMIC/CARBON 304 STAINLESS STEEL
DRAIN AND FILL CAP MATERIAL	ACRYLONITRILE BUTADIENE STYRENE
SALT OR CHEMICALS	NO
PUMP HARDWARE	ZINC PLATED STEEL
MAX. FLUID TEMPERATURE	104° F (40° C)
MAX. SOLID HANDLING	0.18 in (4.5 mm)
O-RINGS	NITRILE BUTADIENE RUBBER
STRAINER SIZE	1.5 in (38.1 mm) NPT
STRAINER INLET SIZE	0.098 in (2.5 mm)

ENGINE SPECIFICATIONS	
MAKE/MODEL	HONDA/GXH50
EMISSIONS	EPA CERTIFIED AND CARB PREEMPT
STARTING METHOD	RECOIL START
DESIGN	AIR-COOLED, 4 STROKE, SINGLE CYLINDER, OHV, HORIZONTAL SHAFT
DISPLACEMENT	49.4 CC (3.0 CU-IN)
BORE X STROKE	1.6 x 1.42 in (41.8 x 36 mm)
HORSE POWER (kW)	2.1 (1.6)
ENGINE SPEED	7,000 RPM
GOVERNOR SPEED	MECHANICAL
SOUND LEVEL dB(A) AT 23 FT	74
AIR CLEANER	SINGLE ELEMENT
LUBRICATION SYSTEM	SPLASH
SPARK ARRESTOR	OPTIONAL
OIL CAPACITY	0.26 QUARTS (0.25 LITERS)
OIL TYPE	SAE 10W-30
LOW OIL SHUT-DOWN	STANDARD

FUEL SPECIFICATIONS	
RECOMMENDED FUEL	UNLEADED GASOLINE
FUEL TANK CAPACITY	0.203 GALLONS (0.77 L)
FUEL CONSUMPTION	0.24 GPH (0.91 LPH)
RUN TIME	0.85 HOURS

WEIGHT AND DIMENSIONS	
DRY WEIGHT	22.0 lb (10 kg)
DIMENSIONS	15.7 x 10.8 x 14.8 in (400 x 275 x 375 mm)

NOTICE Features and Specifications are subject to change without notice.

OPTIONS

SUCTION HOSES

- **HS1520C** - 1.5" x 20 ft., 65psi, rigid PVC helix reinforced, NPS thread
- **HSQ1520C** - 1.5" x 20 ft., 65psi, rigid PVC helix reinforced, NPT thread, Male Camlock, includes one quick disconnect coupler
- **HS1525C** - 1.5" x 25 ft., 65psi, rigid PVC helix reinforced, NPS thread
- **HSQ1525C** - 1.5" x 25 ft., 65psi, rigid PVC helix reinforced, NPT thread, Male Camlock, includes one quick disconnect coupler
- **A150A** - 1.5" type A coupler, male quick disconnect x female NPT



HS1520C and HS1525C

HSQ1520C and HSQ1525C

DISCHARGE HOSES

- **HD1550C** - 1.5" x 50 ft., 75psi, NPS thread
- **HDQ1550C** - 1.5" x 50 ft., 75psi, NPT thread quick coupler
- **HDQ1550HP** - 1.5" x 50 ft., 75psi, NPT thread quick coupler, high pressure
- **FIRENOZ15** - 1.5" nozzle, NPT thread
- **A150A** - 1.5" type A coupler, male quick disconnect x female NPT



HD1550C

HDQ1550C

HDQ1550HP



FIRENOZ15



A150A