



# QP2TK

MULTIQUIP® 2" Trash Pump

GALLONS PER MINUTE

**172 (650 L)**

HEAD

**87 ft (26.5 M)**

ENGINE

**Kubota OC60-E4**

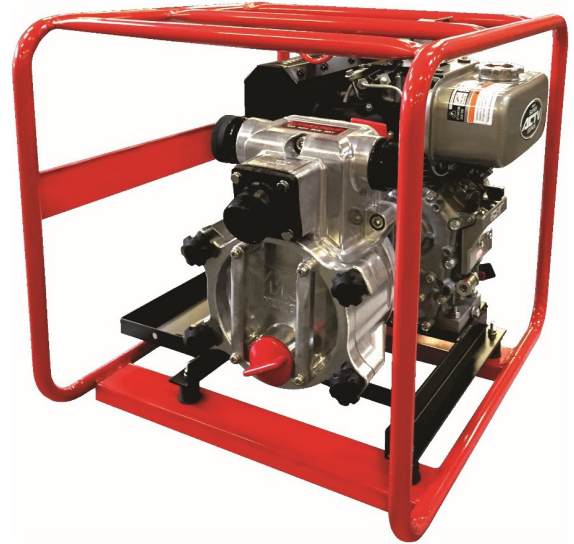

## APPLICATIONS

Agricultural, Construction Sites, Dirty Water, Emergency Response, Excavation, Farms, Floods, Irrigation, Jobsite Drainage, Mining, Municipalities, Standing Water, Swimming Pools, Quarries, Water Departments, Water Supply from Lakes/Rivers

## STANDARD FEATURES

- Maximum pumping capacity of **172 gallons (650 liters)** per minute.
- Maximum lift of **25 feet (7.6 meters)**.
- Die-cast aluminum body with cast-iron fittings.
- Large cleanout cover removes in seconds.
- Pumps water with solid content as large as **1" (25.4 mm)** in diameter.
- High-Efficiency impeller and volute for maximum fluid transfer.
- Ductile Iron impeller and cast iron volute for abrasion resistance/long life.
- Durable silicon carbide mechanical seal provides extreme abrasion resistance and high temperature operation
- **Dual 2-inch discharge ports** for easy hose orientation and flexibility.
- **1.5" (38.1 mm)** diameter fill and drain ports
- Trusted **6.0HP Kubota OC60-E4 diesel engine**.
- Heavy-duty **1" (25.4 mm) tubular steel frame** for transportation and pump protection.

## WARRANTY\*

**QP2TK:** 24 months from date of purchase.

**Kubota OC60-E4 Engine:** 36 months from date of purchase.

**Hoses:** 3 months from date of purchase.

\*Refer to the MULTIQUIP NEW PRODUCT LIMITED WARRANTY FOR FULL TERMS AND CONDITIONS.

## FEATURES

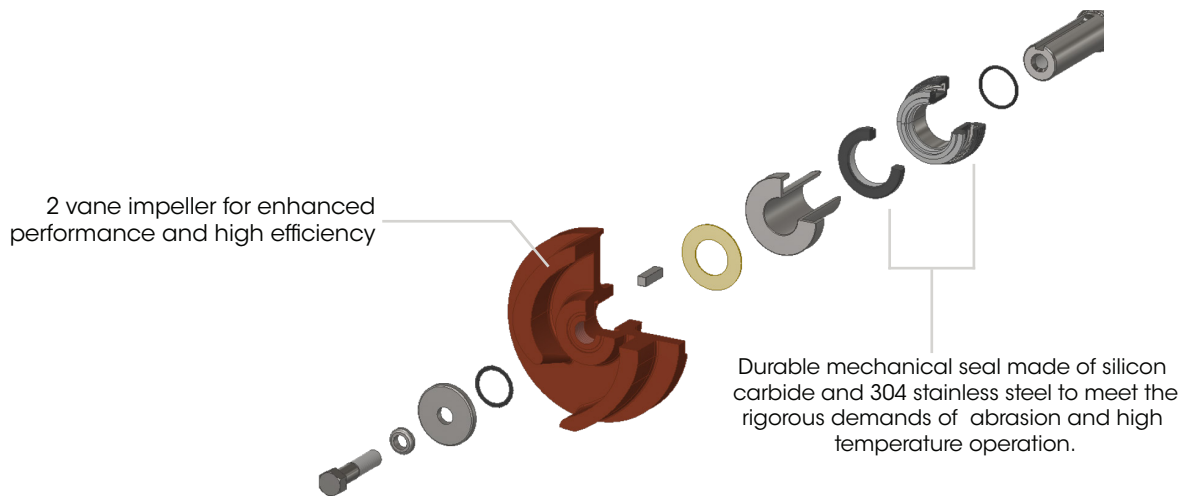
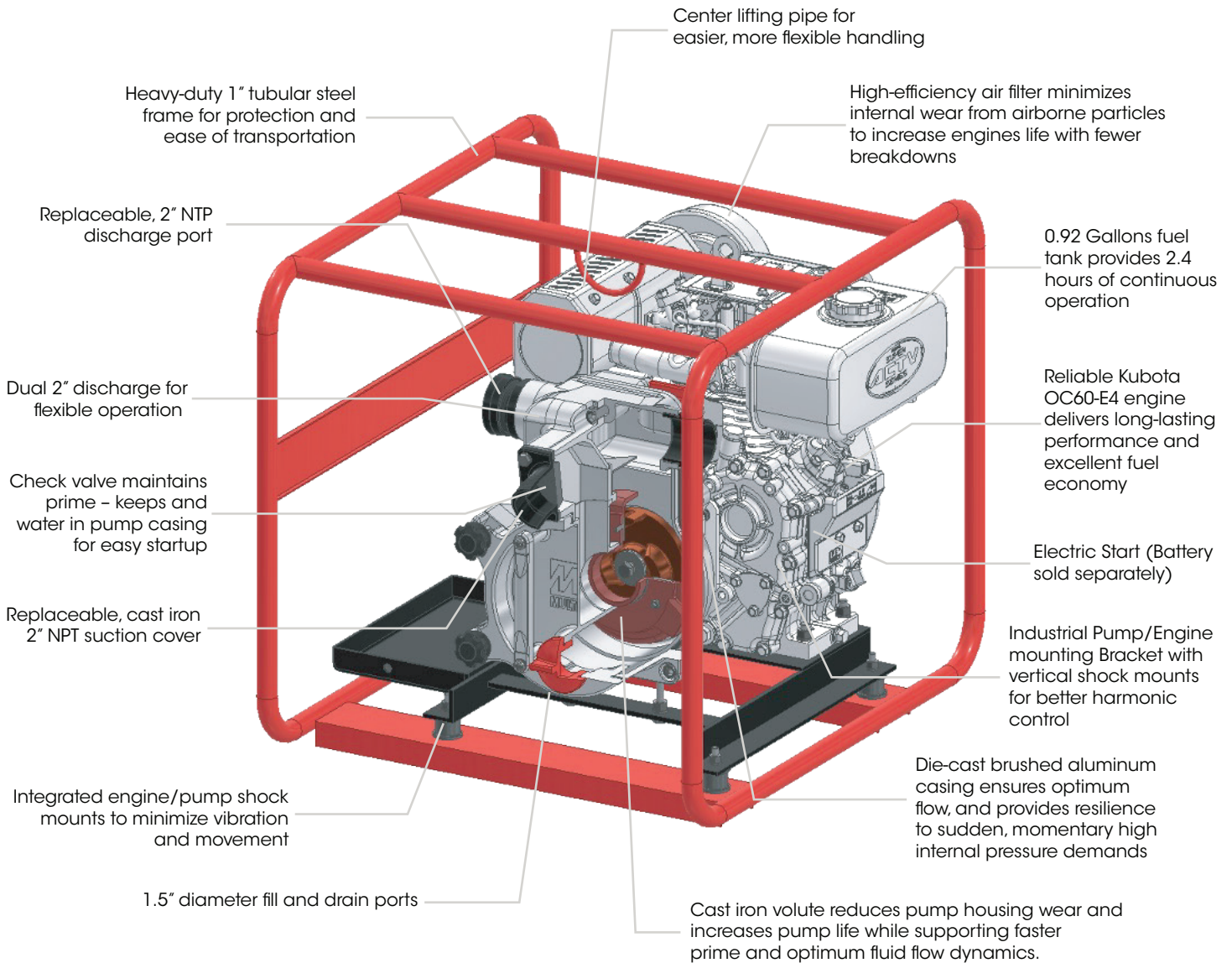

© COPYRIGHT 2026 MULTIQUIP INC. (REV 03242026)

**PUMP CURVE**

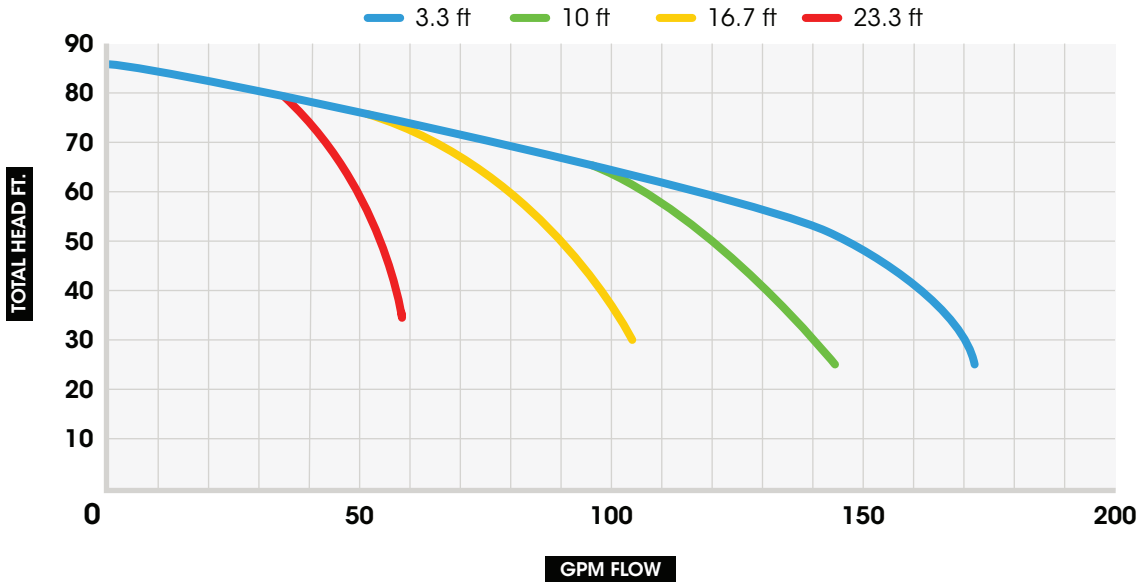

**PUMP DIMENSIONS**

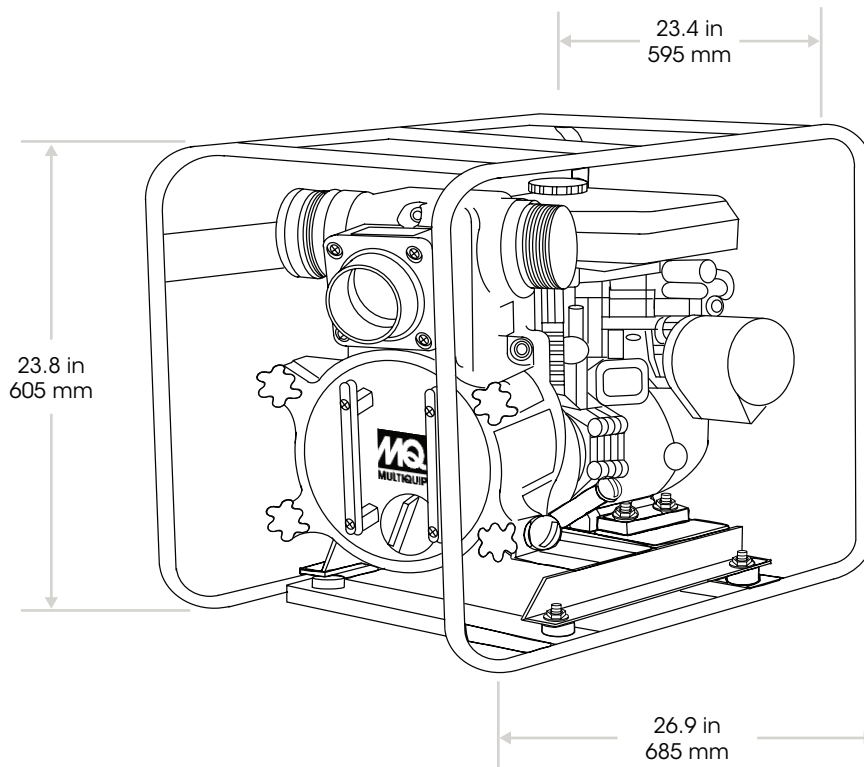

## SPECIFICATIONS

PUMP SPECIFICATIONS	
MODEL	QP2TK
TYPE	TRASH PUMP
IMPELLER TYPE	SEMI-OPEN
MAX. PUMP CAPACITY	172 GALLONS/MINUTE (650 L/MIN)
MAX. SUCTION	25 FT. (7.62 M)
MAX. HEAD	87 FT. (26.5 METERS)
SUCTION/DISCHARGE PORT SIZE	2 IN. (50.8 MM)
THREAD TYPE	NPT (MALE)
PSI	37.7
IMPELLER MATERIAL	DUCTILE IRON
VOLUTE MATERIAL	CAST IRON
PUMP CASING MATERIAL	DIE-CAST ALUMINUM
CHECK VALVE MATERIAL	NITRILE BUTADIENE RUBBER
MECHANICAL SEAL MATERIAL	SILICON CARBIDE/304 STAINLESS STEEL
DRAIN AND FILL CAP MATERIAL	ACRYLONITRILE BUTADIENE STYRENE
SALT OR CHEMICALS	NO
PUMP HARDWARE	STAINLESS STEEL
MAX. FLUID TEMPERATURE	104° F (40° C)
MAX. SOLID HANDLING	1 IN (25.4 MM)
O-RINGS	NITRILE BUTADIENE RUBBER
STRAINER SIZE	2 IN (50.8 MM) NPT
STRAINER INLET SIZE	0.79 IN (20 MM)

ENGINE SPECIFICATIONS	
MAKE/MODEL	KUBOTA/OC60-E4
EMISSIONS	EPA CERTIFIED AND CARB PREEMPT
STARTING METHOD	RECOIL AND ELECTRIC START
DESIGN	AIR-COOLED, 4 STROKE, SINGLE CYLINDER, OHV, HORIZONTAL SHAFT
DISPLACEMENT	276 CC (16.8 CU-IN)
BORE X STROKE	2.83 IN. X 2.68 IN (72 MM X 68 MM)
HORSE POWER (KW)	6.0 (4.5)
ENGINE SPEED	3,600 RPM
GOVERNOR SPEED	MECHANICAL CENTRIFUGAL
SOUND LEVEL dB(A) AT 23 FT	75
AIR CLEANER	SINGLE ELEMENT
LUBRICATION SYSTEM	FORCED LUBRICATION WITH TROCHOID
SPARK ARRESTOR	OPTIONAL
OIL CAPACITY	1.37 QUARTS (1.3 LITERS)
OIL TYPE	SAE 10W-30
LOW OIL SHUT-DOWN	NO
BATTERY	OPTIONAL
BATTERY TYPE	12N24-3A

FUEL SPECIFICATIONS	
RECOMMENDED FUEL	DIESEL, ASTM-D975-NO.2-D S500 OR S15
FUEL TANK CAPACITY	0.92 GALLONS (3.5 LITERS)
FUEL CONSUMPTION	0.38 GPH (1.45 LPH)
RUN TIME	2.4 HOURS

WEIGHT AND DIMENSIONS	
DRY WEIGHT	177.5 LB. (80.5 KG)
DIMENSIONS	26.9 X 23.4 X 23.8 IN. (685 X 595 X 605 MM)

## OPTIONS

### SUCTION HOSES

- **HS220C** - 2" x 20 ft., 65psi, rigid PVC helix reinforced, NPS thread
- **HSQ220C** - 2" x 20 ft., 65psi, rigid PVC helix reinforced, NPT thread, Male Camlock, includes one quick disconnect coupler
- **HS225C** - 2" x 25 ft., 65psi, rigid PVC helix reinforced, NPS thread
- **HSQ225C** - 2" x 25 ft., 65psi, rigid PVC helix reinforced NPT thread, Male Camlock, includes one quick disconnect coupler
- **A200A** - 2" type A coupler, male quick disconnect x female NPT



HS220C AND HS225C

HSQ220C AND HSQ225C

### DISCHARGE HOSES

- **HD250C** - 2" x 50 ft., 75psi, NPS thread
- **HDQ250C** - 2" x 50 ft., 75psi NPT thread, includes one quick disconnect coupler
- **A200A** - 2" type A coupler, male quick disconnect x female NPT



HD250C

HDQ250C

A200A

### FILTER KIT

- **FKITQP3TK** - (1) Air cleaner element, (1) oil screen and (1) fuel strainer

### WHEEL KIT

- **UWKB** - Wheel kit with folding handles and flat free tires for easy transport

**NOTICE** Features and Specifications are subject to change without notice.