



QP4TK

MULTIQUIP® 4" Trash Pump

GALLONS PER MINUTE

475 (1798 L)

HEAD

87 ft (26.5 M)

ENGINE

Kubota OC95-E4

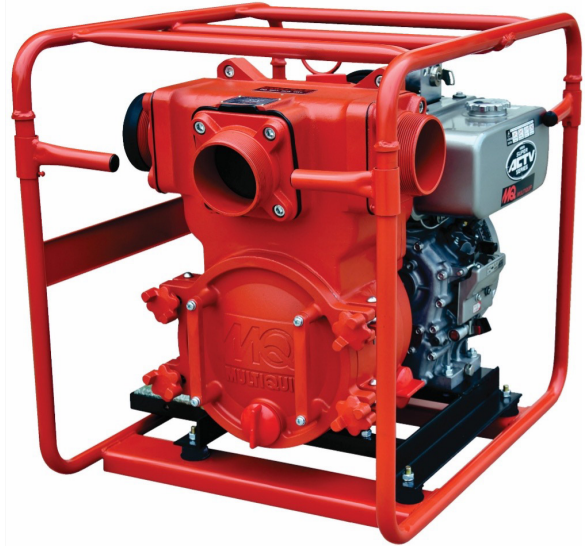

APPLICATIONS

Agricultural, Construction Sites, Dirty Water, Emergency Response, Excavation, Farms, Floods, Irrigation, Jobsite Drainage, Mining, Municipalities, Standing Water, Swimming Pools, Quarries, Water Departments, Water Supply from Lakes/Rivers

STANDARD FEATURES

- Maximum pumping capacity of **475 gallons (1798 liters) per minute**.
- Maximum lift of **25 feet (7.6 meters)**.
- Sand-cast aluminum body with cast-iron fittings.
- Large cleanout cover removes in seconds.
- Pumps water with solid content as large as **2.0-inch (50.8 mm)** in diameter.
- High-Efficiency impeller and volute for maximum fluid transfer.
- Ductile Iron impeller and cast iron volute for abrasion resistance/long life.
- Durable silicon carbide mechanical seal provides extreme abrasion resistance and high temperature operation
- **Dual 4-inch discharge** ports for easy hose orientation and flexibility.
- **1.5" (38.1 mm)** diameter fill and drain ports
- Trusted **9.4HP Kubota OC95-E4** diesel engine.
- Heavy-duty **1.07" (27.2 mm)** tubular steel frame for transportation and pump protection.

WARRANTY*

QP4TK: 24 months from date of purchase.

Kubota OC95-E4 Engine: 36 months from date of purchase.

Hoses: 3 months from date of purchase.

*Refer to the MULTIQUIP NEW PRODUCT LIMITED WARRANTY FOR FULL TERMS AND CONDITIONS.

FEATURES

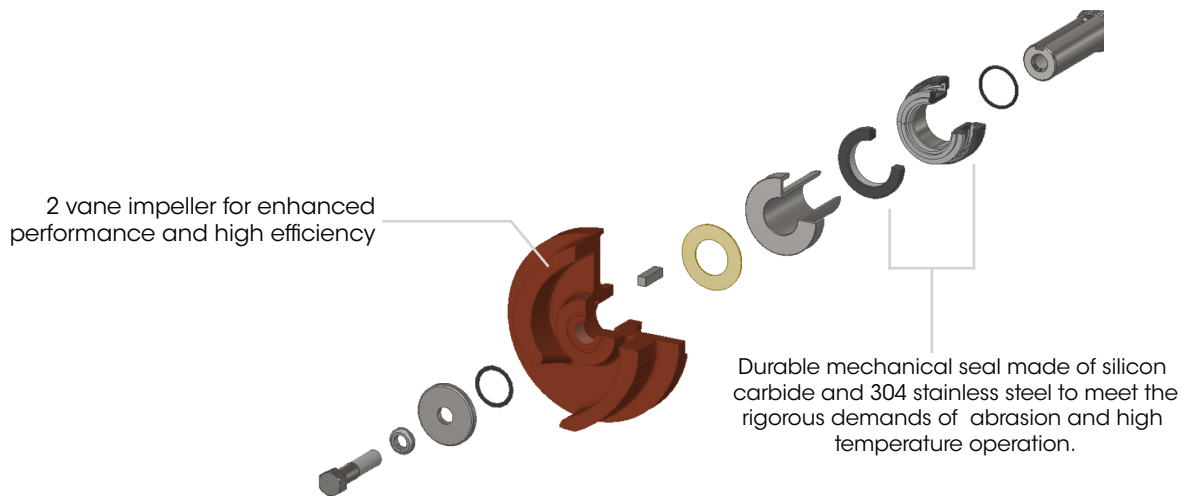
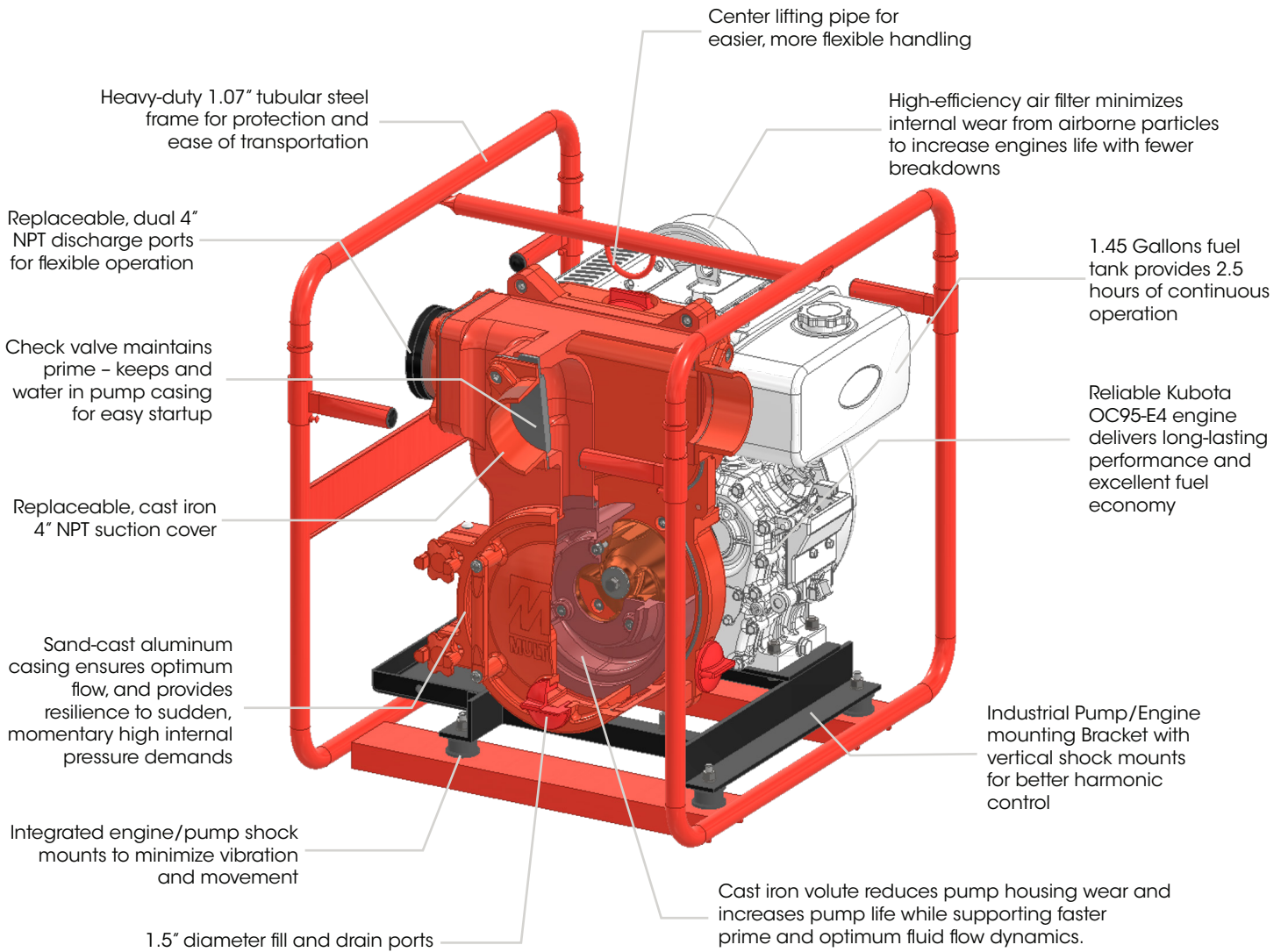

© COPYRIGHT 2026 MULTIQUIP INC. (REV 03242026)

PUMP CURVE

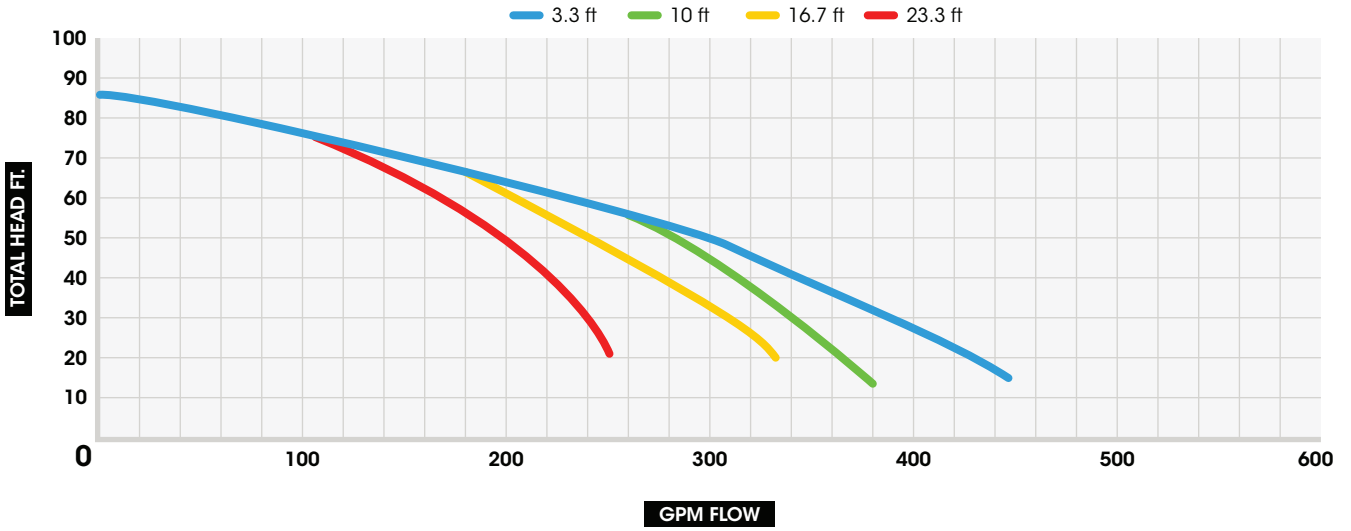

PUMP DIMENSIONS

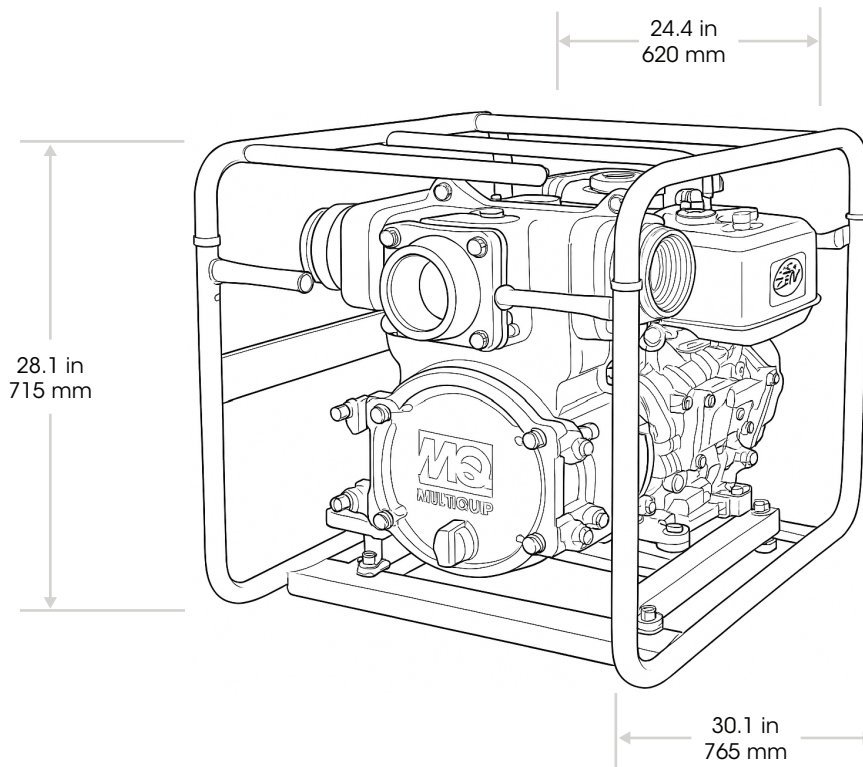

SPECIFICATIONS

PUMP SPECIFICATIONS	
MODEL	QP4TK
TYPE	TRASH PUMP
IMPELLER TYPE	SEMI-OPEN
MAX. PUMP CAPACITY	475 GALLONS/MINUTE (1798 L/MIN)
MAX. SUCTION	25 FT. (7.62 M)
MAX. HEAD	87 FT. (26.5 METERS)
SUCTION/DISCHARGE PORT SIZE	4 IN. (100 MM)
THREAD TYPE	NPT (MALE)
PSI	37.7
IMPELLER MATERIAL	DUCTILE IRON
VOLUTE MATERIAL	CAST IRON
PUMP CASING MATERIAL	SAND-CAST ALUMINUM
CHECK VALVE MATERIAL	NITRILE BUTADIENE RUBBER
MECHANICAL SEAL MATERIAL	SILICON CARBIDE/304 STAINLESS STEEL
DRAIN AND FILL CAP MATERIAL	ACRYLONITRILE BUTADIENE STYRENE
SALT OR CHEMICALS	NO
PUMP HARDWARE	STEEL
MAX. FLUID TEMPERATURE	104° F (40° C)
MAX. SOLID HANDLING	2 IN (50.8 MM)
O-RINGS	NITRILE BUTADIENE RUBBER
STRAINER SIZE	4 IN (100 MM) NPT
STRAINER INLET SIZE	1.06 IN (27.0 MM)
BATTERY	OPTIONAL
BATTERY TYPE	12N24-3A

ENGINE SPECIFICATIONS	
MAKE/MODEL	KUBOTA/OC95-E4
EMISSIONS	EPA CERTIFIED AND CARB PREEMPT
STARTING METHOD	RECOIL/ELECTRIC START
DESIGN	AIR-COOLED, 4 STROKE, SINGLE CYLINDER, INDIRECT INJECTION, HORIZONTAL SHAFT
DISPLACEMENT	416 CC (25.4 CU-IN)
BORE X STROKE	3.27 IN. X 3.03 IN (83 MM X 77 MM)
HORSE POWER (KW)	9.4 (7.0)
ENGINE SPEED	3,600 RPM
GOVERNOR SPEED	MECHANICAL
SOUND LEVEL dB(A) AT 23 FT	80
AIR CLEANER	SINGLE ELEMENT
LUBRICATION SYSTEM	FORCED LUBRICATION WITH TROCHOID PUMP
SPARK ARRESTOR	OPTIONAL
OIL CAPACITY	1.8 QUARTS (1.7 LITERS)
OIL TYPE	SAE 10W-30

FUEL SPECIFICATIONS	
RECOMMENDED FUEL	DIESEL, ASTM-D975-NO.2-D S500 OR S15
FUEL TANK CAPACITY	1.45 GALLONS (5.5 LITERS)
FUEL CONSUMPTION	0.58 GPH (2.2 LPH)
RUN TIME	2.5 HOURS

WEIGHT AND DIMENSIONS	
DRY WEIGHT	293.2 LB. (133.0 KG)
DIMENSIONS	30.1 X 24.4 X 28.1 IN (765 X 620 X 715 MM)

OPTIONS

SUCTION HOSES

- **HS420C** - 4" x 20 ft., 65psi, rigid PVC helix reinforced, NPS thread
- **HSQ420C** - 4" x 20 ft., 65psi, rigid PVC helix reinforced, NPT thread, Male Camlock, includes one quick disconnect coupler
- **HS425C** - 4" x 25 ft., 65psi, rigid PVC helix reinforced, NPS thread
- **HSQ425C** - 4" x 25 ft., 65psi, rigid PVC helix reinforced NPT thread, Male Camlock, includes one quick disconnect coupler
- **A400A** - 4" type A coupler, male quick disconnect x female NPT



HS420C AND HS425C

HSQ420C AND HSQ425C

DISCHARGE HOSES

- **HD450C** - 4" x 50 ft., 60psi, NPS thread
- **HDQ450C** - 4" x 50 ft., 60psi NPT thread, includes one quick disconnect coupler
- **A400A** - 4" type A coupler, male quick disconnect x female NPT



HD450C

HDQ450C

A400A

FILTER KIT

- **FKITQP4TK** - (1) Air cleaner element, (1) oil screen and (1) fuel strainer

WHEEL KIT

- **UWKB** - Wheel kit with folding handles and flat free tires for easy transport

NOTICE Features and Specifications are subject to change without notice.