



This bulletin is provided for technical reference and service related updates. If you have any questions, comments or do not wish to receive these e-mails, please reply to this e-mail or call the Service Technical Support Group 800 478-1244.

ANGLE BRACKET MODIFICATION

It has been noted as a pre-caution for the angle bracket to be trimmed.

This information is provided as a pre-caution, as this note was taken when a machine became accidentally hit, causing the top cover to shift in result; damaging the receiver eye. Trimming the angle bracket will provide more clearance to the receiver eye.

The receiver eye is mounted to the top cover and is located just above the angle bracket.

Production Change

Effective Serial Number.....1839464

Machines beginning with serial number 1839464 will be manufactured with trimmed angle bracket.

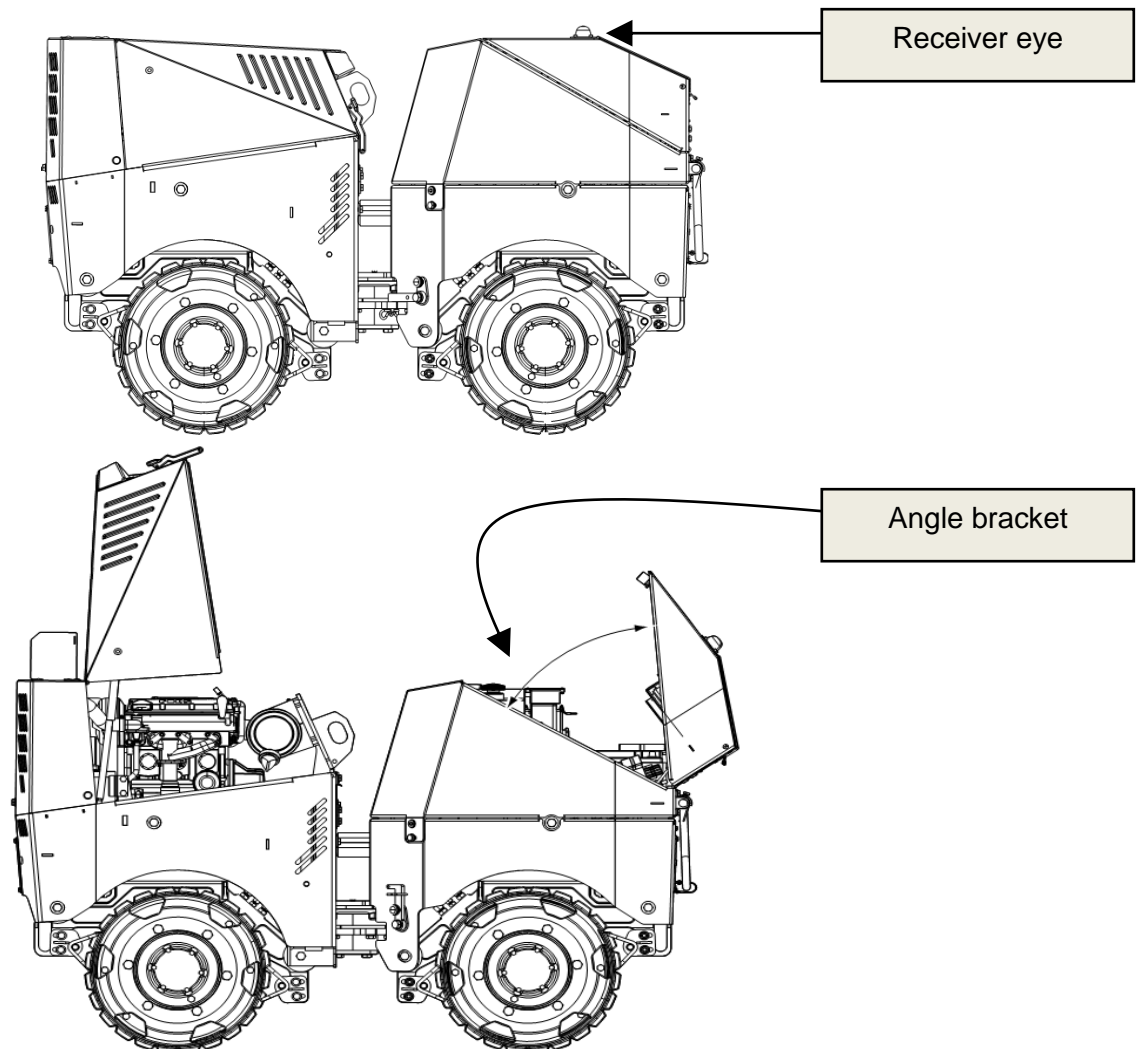

The angle bracket houses the idle control module and remote receiver, in order to trim the angle bracket it will be necessary to remove the idle control module and receiver.

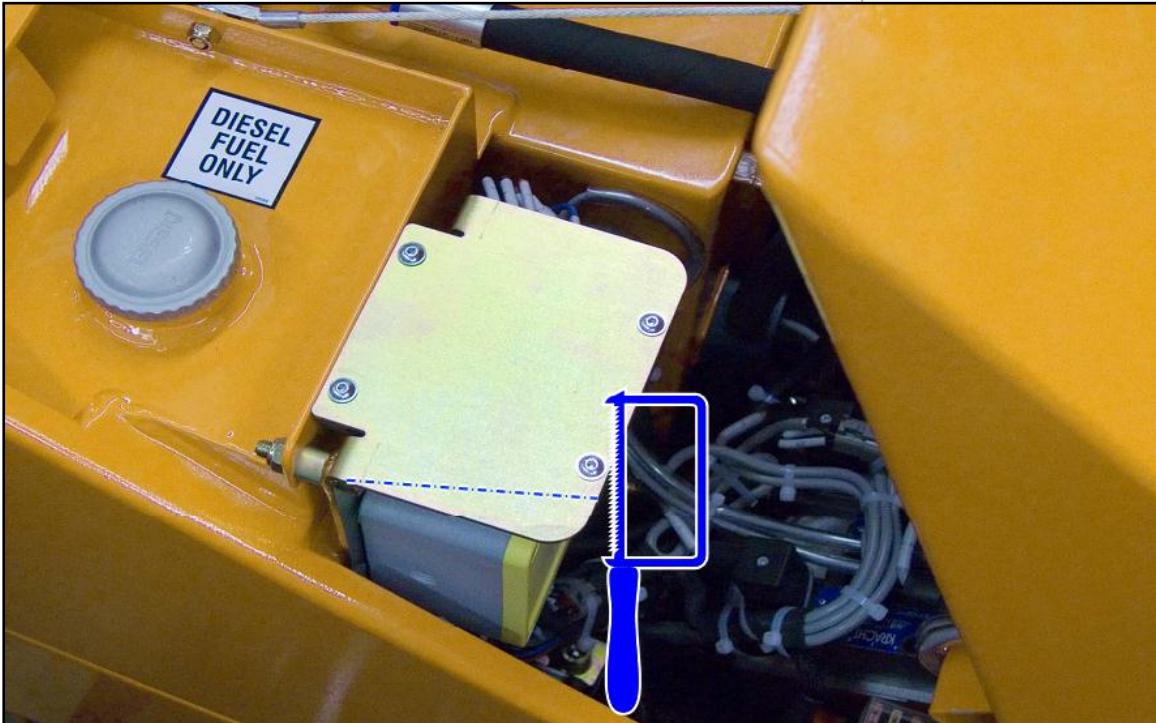
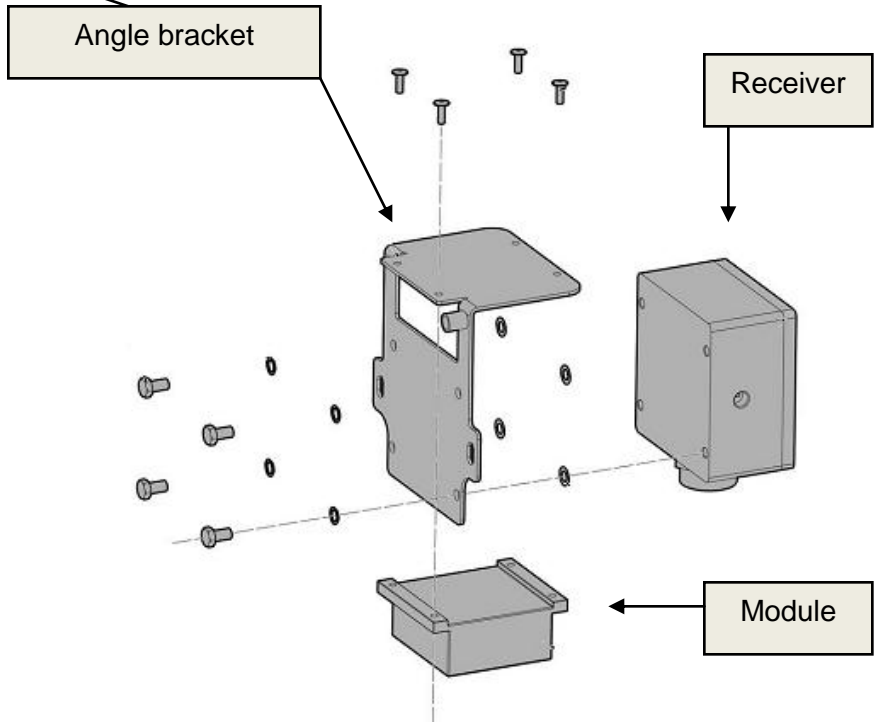

TOP VIEW

